



This PDF is provided by the International Telecommunication Union (ITU) Library & Archives Service from an officially produced electronic file.

Ce PDF a été élaboré par le Service de la bibliothèque et des archives de l'Union internationale des télécommunications (UIT) à partir d'une publication officielle sous forme électronique.

Este documento PDF lo facilita el Servicio de Biblioteca y Archivos de la Unión Internacional de Telecomunicaciones (UIT) a partir de un archivo electrónico producido oficialmente.

یجر ی نور کتابا فمل ن م تنخوما ی هو ت اظوفحموال، ت مکتبال قسم ، (ITU) تصالاتلا ی لوالد ادحتالا ن م تممقد PDF ق سنبا تخسناا هذه امیرس داده عا.

本PDF版本由国际电信联盟（ITU）图书馆和档案服务室提供。来源为正式出版的电子文件。

Настоящий файл в формате PDF предоставлен библиотечно-архивной службой Международного союза электросвязи (МСЭ) на основе официально созданного электронного файла.

# Radio Regulations

## Appendices

Edition of 2020

# 2





# Radio Regulations

## Appendices

Edition of 2020

# 2



**Disclaimer**

The designations employed and the presentation of material in this Publication do not imply the expression of any opinion whatsoever on the part of ITU and of the Secretariat of the ITU concerning the legal status of the countries, territories, cities or areas or their authorities, or concerning the delimitation of their frontiers or boundaries.

© ITU 2020

All rights reserved. No part of this publication may be reproduced, by any means whatsoever, without the prior written permission of ITU.

## Note by the Secretariat

This revision of the Radio Regulations, complementing the Constitution and the Convention of the International Telecommunication Union, incorporates the decisions of the World Radio-communication Conferences of 1995 (WRC-95), 1997 (WRC-97), 2000 (WRC-2000), 2003 (WRC-03), 2007 (WRC-07), 2012 (WRC-12), 2015 (WRC-15) and 2019 (WRC-19). The majority of the provisions of these Regulations shall enter into force as from 1 January 2021; the remaining provisions shall apply as from the special dates of application indicated in Article 59 of the revised Radio Regulations.

In preparing the Radio Regulations, Edition of 2020, the Secretariat corrected the typographical errors that were drawn to the attention of WRC-19 and which were approved by WRC-19.

This edition uses the same numbering scheme as the 2001 edition of the Radio Regulations, notably:

**With respect to Article numbers**, this edition follows the standard sequential numbering. The Article numbers are not followed by any abbreviation (such as “(WRC-97)”, “(WRC-2000)”, “(WRC-03)”, “(WRC-07)”, “(WRC-12)”, “(WRC-15)” or “(WRC-19)”). Consequently, any reference to an Article, in any of the provisions of these Radio Regulations (e.g. in No. 13.1 of Article 13), in the texts of the Appendices as contained in Volume 2 of this edition (e.g. in § 1 of Appendix 2), in the texts of the Resolutions included in Volume 3 of this edition (e.g. in Resolution 1 (Rev.WRC-97)), and in the texts of the Recommendations included in Volume 3 of this edition (e.g. in Recommendation 8), is considered as a reference to the text of the concerned Article which appears in this edition, unless otherwise specified.

**With respect to provision numbers in Articles**, this edition continues to use composite numbers indicating the number of the Article and the provision number within that Article (e.g. No. 9.2B means provision No. 2B of Article 9). The abbreviation “(WRC-19)”, “(WRC-15)”, “(WRC-12)”, “(WRC-07)”, “(WRC-03)”, “(WRC-2000)” or “(WRC-97)” at the end of such a provision means that the relevant provision was modified or added by WRC-19, by WRC-15, by WRC-12, by WRC-07, by WRC-03, by WRC-2000 or by WRC-97, as applicable. The absence of an abbreviation at the end of the provision means that the provision is identical with the provision of the simplified Radio Regulations as approved by WRC-95, and whose complete text was contained in Document 2 of WRC-97.

**With respect to Appendix numbers**, this edition follows the standard sequential numbering, with the addition of the appropriate abbreviation after the Appendix number (such as “(WRC-97)”, “(WRC-2000)”, “(WRC-03)”, “(WRC-07)”, “(WRC-12)”, “(WRC-15)” or “(WRC-19)”), where applicable. As a rule, any reference to an Appendix, in any of the provisions of these Radio Regulations, in the texts of the Appendices as contained in Volume 2 of this edition, in the texts of the Resolutions and of the Recommendations included in Volume 3 of this edition, is presented in the standard manner (e.g. “Appendix 30 (Rev.WRC-19)”) if not explicitly described in the text (e.g. Appendix 4 as modified by WRC-19). In the texts of Appendices that were partially modified by WRC-19, the provisions that were modified by WRC-19 are indicated with the abbreviation “(WRC-19)” at the end of the concerned text. If an Appendix is referenced without any abbreviation after the Appendix number, in the texts of this edition (e.g. in No. 13.1), or without other description, such reference is considered as a reference to the text of the concerned Appendix which appears in this edition.

Within the text of the Radio Regulations, the symbol, ↑, has been used to represent quantities associated with an uplink. Similarly, the symbol, ↓, has been used to represent quantities associated with a downlink.

Abbreviations have generally been used for the names of world administrative radio conferences and world radiocommunication conferences. These abbreviations are shown below.

<b>Abbreviation</b>	<b>Conference</b>
WARC Mar	World Administrative Radio Conference to Deal with Matters Relating to the Maritime Mobile Service (Geneva, 1967)
WARC-71	World Administrative Radio Conference for Space Telecommunications (Geneva, 1971)
WMARC-74	World Maritime Administrative Radio Conference (Geneva, 1974)
WARC SAT-77	World Broadcasting-Satellite Administrative Radio Conference (Geneva, 1977)
WARC-Aer2	World Administrative Radio Conference on the Aeronautical Mobile (R) Service (Geneva, 1978)
WARC-79	World Administrative Radio Conference (Geneva, 1979)
WARC Mob-83	World Administrative Radio Conference for the Mobile Services (Geneva, 1983)
WARC HFBC-84	World Administrative Radio Conference for the Planning of the HF Bands Allocated to the Broadcasting Service (Geneva, 1984)
WARC Orb-85	World Administrative Radio Conference on the Use of the Geostationary-Satellite Orbit and the Planning of Space Services Utilising It (First Session – Geneva, 1985)
WARC HFBC-87	World Administrative Radio Conference for the Planning of the HF Bands Allocated to the Broadcasting Service (Geneva, 1987)
WARC Mob-87	World Administrative Radio Conference for the Mobile Services (Geneva, 1987)
WARC Orb-88	World Administrative Radio Conference on the Use of the Geostationary-Satellite Orbit and the Planning of Space Services Utilising It (Second Session – Geneva, 1988)
WARC-92	World Administrative Radio Conference for Dealing with Frequency Allocations in Certain Parts of the Spectrum (Malaga-Torremolinos, 1992)
WRC-95	World Radiocommunication Conference (Geneva, 1995)
WRC-97	World Radiocommunication Conference (Geneva, 1997)
WRC-2000	World Radiocommunication Conference (Istanbul, 2000)
WRC-03	World Radiocommunication Conference (Geneva, 2003)
WRC-07	World Radiocommunication Conference (Geneva, 2007)
WRC-12	World Radiocommunication Conference (Geneva, 2012)
WRC-15	World Radiocommunication Conference (Geneva, 2015)
WRC-19	World Radiocommunication Conference (Sharm El-Sheikh, 2019)
WRC-23	World Radiocommunication Conference, 2023 <sup>1</sup>

---

<sup>1</sup> The date of this conference has not been finalized.

## VOLUME 2

### Appendices

#### TABLE OF CONTENTS

	<i>Page</i>
APPENDIX 1 (REV.WRC-19) Classification of emissions and necessary bandwidths .....	3
APPENDIX 2 (REV.WRC-03) Table of transmitter frequency tolerances.....	9
APPENDIX 3 (REV.WRC-12) Maximum permitted power levels for unwanted emissions in the spurious domain .....	17
ANNEX 1 Determination of the boundary between the out-of-band and spurious domains.....	23
APPENDIX 4 (REV.WRC-19) Consolidated list and tables of characteristics for use in the application of the procedures of Chapter III .....	27
ANNEX 1 Characteristics of stations in the terrestrial services...	27
ANNEX 2 Characteristics of satellite networks, earth stations or radio astronomy stations.....	67
APPENDIX 5 (REV.WRC-19) Identification of administrations with which coordination is to be effected or agreement sought under the provisions of Article 9.....	121
ANNEX 1 .....	140
APPENDIX 7 (REV.WRC-19) Methods for the determination of the coordination area around an earth station in frequency bands between 100 MHz and 105 GHz.....	149
ANNEX 1 Determination of the required distance for propagation mode (1).....	176
ANNEX 2 Determination of the required distance for propagation mode (2).....	186



ANNEX 3	Antenna gain towards the horizon for an earth station operating with a geostationary space station .....	195
ANNEX 4	Antenna gain toward the horizon for an earth station operating with non-geostationary space stations .....	199
ANNEX 5	Determination of the coordination area for a transmitting earth station with respect to receiving earth stations operating with geostationary space stations in bidirectionally allocated frequency bands	204
ANNEX 6	Supplementary and auxiliary contours .....	209
ANNEX 7	System parameters and predetermined coordination distances for determination of the coordination area around an earth station.....	220
APPENDIX 8	(REV.WRC-15) Method of calculation for determining if coordination is required between geostationary-satellite networks sharing the same frequency bands.....	239
ANNEX 1	Calculation of the topocentric angular separation between two geostationary satellites .....	245
ANNEX 2	Calculation of the free-space transmission loss.....	245
ANNEX 3	Radiation patterns for earth station antennas to be used when they are not published.....	246
ANNEX 4	Example of an application of Appendix 8 .....	247
APPENDIX 9	Report of an irregularity or infringement.....	251
APPENDIX 10	(REV.WRC-07) Report of harmful interference.....	255
APPENDIX 11	(REV.WRC-19) System specifications for double-sideband (DSB), single-sideband (SSB) and digitally modulated emissions in the HF broadcasting service .....	257
APPENDIX 12	Special rules applicable to radiobeacons.....	263

APPENDIX 14	(REV.WRC-07) Phonetic alphabet and figure code .....	265
APPENDIX 15	(REV.WRC-19) Frequencies for distress and safety communications for the Global Maritime Distress and Safety System .....	267
APPENDIX 16	(REV.WRC-07) Documents with which stations on board ships and aircraft shall be provided.....	271
APPENDIX 17	(REV.WRC-19) Frequencies and channelling arrangements in the high-frequency bands for the maritime mobile service.....	273
APPENDIX 18	(REV.WRC-19) Table of transmitting frequencies in the VHF maritime mobile band.....	299
APPENDIX 25	(REV.WRC-03) Provisions and associated frequency allotment Plan for coast radiotelephone stations operating in the exclusive maritime mobile bands between 4 000 kHz and 27 500 kHz.....	305
APPENDIX 26	(REV.WRC-15) Provisions and associated Frequency Allotment Plan for the aeronautical mobile (OR) service in the bands allocated exclusively to that service between 3 025 kHz and 18 030 kHz.....	341
APPENDIX 27	(REV.WRC-19) Frequency allotment Plan for the aeronautical mobile (R) service and related information.....	367
APPENDIX 30	(REV.WRC-19) Provisions for all services and associated Plans and List for the broadcasting-satellite service in the frequency bands 11.7-12.2 GHz (in Region 3), 11.7-12.5 GHz (in Region 1) and 12.2-12.7 GHz (in Region 2).....	443
ANNEX 1	Limits for determining whether a service of an administration is affected by a proposed modification to the Region 2 Plan or by a proposed new or modified assignment in the Regions 1 and 3 List or when it is necessary under this Appendix to seek the agreement of any other administration .....	531

ANNEX 2	Basic characteristics to be furnished in notices relating to space stations in the broadcasting-satellite service.....	536
ANNEX 3	Method for determining the limiting interfering power flux-density at the edge of a broadcasting-satellite service area in the frequency bands 11.7-12.2 GHz (in Region 3), 11.7-12.5 GHz (in Region 1) and 12.2-12.7 GHz (in Region 2), and for calculating the power flux-density produced in these bands by a terrestrial station, or by a transmitting earth station in the fixed-satellite service in the band 12.5-12.7 GHz	536
ANNEX 4	Need for coordination of a transmitting space station in the fixed-satellite service or in the broadcasting-satellite service where this service is not subject to a Plan: in Region 2 (11.7-12.2 GHz) with respect to the Plan, the List or proposed new or modified assignments in the List for Regions 1 and 3; in Region 1 (12.5-12.7 GHz) and in Region 3 (12.2-12.7 GHz) with respect to the Plan or proposed modifications to the Plan in Region 2; in Region 3 (12.2-12.5 GHz) with respect to the Plan, List or proposed new or modified assignments in the List for Region 1.....	545
ANNEX 5	Technical data used in establishing the provisions and associated Plans and the Regions 1 and 3 List, which should be used for their application.....	547
ANNEX 6	Criteria for sharing between services .....	580
ANNEX 7	Orbital position limitations.....	586
APPENDIX 30A	(REV.WRC-19) Provisions and associated Plans and List for feeder links for the broadcasting-satellite service (11.7-12.5 GHz in Region 1, 12.2-12.7 GHz in Region 2 and 11.7-12.2 GHz in Region 3) in the frequency bands 14.5-14.8 GHz and 17.3-18.1 GHz in Regions 1 and 3, and 17.3-17.8 GHz in Region 2.....	587
ANNEX 1	Limits for determining whether a service of an administration is considered to be affected by a proposed modification to the Region 2 feeder-link Plan or by a proposed new or modified assignment in the Regions 1 and 3 feeder-link List or when it is necessary under this Appendix to seek the agreement of any other administration .....	679

ANNEX 2	Basic characteristics to be furnished in notices relating to feeder-link stations in the fixed-satellite service operating in the frequency bands 14.5-14.8 GHz and 17.3-18.1 GHz.....	682
ANNEX 3	Technical data used in establishing the provisions and associated Plans and Regions 1 and 3 feeder-link List, which should be used for their application.....	682
ANNEX 4	Criteria for sharing between services .....	721
APPENDIX 30B	(REV.WRC-19) Provisions and associated Plan for the fixed-satellite service in the frequency bands 4 500-4 800 MHz, 6 725-7 025 MHz, 10.70-10.95 GHz, 11.20-11.45 GHz and 12.75-13.25 GHz.....	723
ANNEX 1	Parameters used in characterizing the fixed-satellite service allotment Plan.....	749
ANNEX 2	(SUP - WRC-07).....	753
ANNEX 3	Limits applicable to submissions received under Article 6 or Article 7.....	753
ANNEX 4	Criteria for determining whether an allotment or an assignment is considered to be affected .....	754
APPENDIX 1	TO ANNEX 4 Method for determination of the overall single-entry and aggregate carrier-to-interference value averaged over the necessary bandwidth of the modulated carrier.....	756
APPENDIX 2	TO ANNEX 4 Method for determination of the carrier-to-noise (C/N) values .....	758
ANNEX 5	(SUP - WRC-07).....	759
ANNEX 6	(SUP - WRC-07).....	759
APPENDIX 42	(REV.WRC-19) Table of allocation of international call sign series	761



# APPENDICES



APPENDIX 1 (REV.WRC-19)

**Classification of emissions and necessary bandwidths**

(See Article 2)

§ 1 1) Emissions shall be designated according to their necessary bandwidth and their classification as explained in this Appendix.

2) Formulae and examples of emissions designated in accordance with this Appendix are given in Recommendation ITU-R SM.1138-3. Further examples may be provided in other ITU-R Recommendations. These examples may also be published in the Preface to the International Frequency Information Circular (BR IFIC). (WRC-19)

**Section I – Necessary bandwidth**

§ 2 1) The necessary bandwidth, as defined in No. 1.152 and determined in accordance with the formulae and examples, shall be expressed by three numerals and one letter. The letter occupies the position of the decimal point and represents the unit of bandwidth. The first character shall be neither zero nor K, M or G.

2) Necessary bandwidths<sup>1</sup>:

between 0.001 and 999 Hz shall be expressed in Hz (letter H);

between 1.00 and 999 kHz shall be expressed in kHz (letter K);

between 1.00 and 999 MHz shall be expressed in MHz (letter M);

between 1.00 and 999 GHz shall be expressed in GHz (letter G).

3) For the full designation of an emission, the necessary bandwidth, indicated in four characters, shall be added just before the classification symbols. When used, the necessary bandwidth shall be determined by one of the following methods:

3.1) use of the formulae and examples of necessary bandwidths and designation of corresponding emissions given in Recommendation ITU-R SM.1138-3; (WRC-19)

3.2) computation, in accordance with other ITU-R Recommendations;

3.3) measurement, in cases not covered by § 3.1) or 3.2) above.

---

<sup>1</sup> Examples:

0.002	Hz	=	H002	6	kHz	=	6K00	1.25	MHz	=	1M25
0.1	Hz	=	H100	12.5	kHz	=	12K5	2	MHz	=	2M00
25.3	Hz	=	25H3	180.4	kHz	=	180K	10	MHz	=	10M0
400	Hz	=	400H	180.5	kHz	=	181K	202	MHz	=	202M
2.4	kHz	=	2K40	180.7	kHz	=	181K	5.65	GHz	=	5G65



**Section II – Classification**

§ 3 The class of emission is a set of characteristics conforming to § 4 below.

§ 4 Emissions shall be classified and symbolized according to their basic characteristics as given in Sub-Section IIA and any optional additional characteristics as provided for in Sub-Section IIB.

§ 5 The basic characteristics (see Sub-Section IIA) are:

- 1) first symbol – type of modulation of the main carrier;
- 2) second symbol – nature of signal(s) modulating the main carrier;
- 3) third symbol – type of information to be transmitted.

Modulation used only for short periods and for incidental purposes (such as, in many cases, for identification or calling) may be ignored provided that the necessary bandwidth as indicated is not thereby increased.

**Sub-Section IIA – Basic characteristics**

§ 6	1) <i>First symbol</i> – Type of modulation of the main carrier	
1.1)	Emission of an unmodulated carrier	N
1.2)	Emission in which the main carrier is amplitude-modulated (including cases where sub-carriers are angle-modulated)	
	1.2.1) Double-sideband	A
	1.2.2) Single-sideband, full carrier	H
	1.2.3) Single-sideband, reduced or variable level carrier	R
	1.2.4) Single-sideband, suppressed carrier	J
	1.2.5) Independent sidebands	B
	1.2.6) Vestigial sideband	C
1.3)	Emission in which the main carrier is angle-modulated	
	1.3.1) Frequency modulation	F
	1.3.2) Phase modulation	G
1.4)	Emission in which the main carrier is amplitude-and angle-modulated either simultaneously or in a pre-established sequence	D
1.5)	Emission of pulses <sup>2</sup>	
	1.5.1) Sequence of unmodulated pulses	P
	1.5.2) A sequence of pulses	
	1.5.2.1) modulated in amplitude	K
	1.5.2.2) modulated in width/duration	L

---

<sup>2</sup> Emissions where the main carrier is directly modulated by a signal which has been coded into quantized form (e.g. pulse code modulation) should be designated under § 1.2) or 1.3).

	1.5.2.3)	modulated in position/phase	M
	1.5.2.4)	in which the carrier is angle-modulated during the angle-period of the pulse	Q
	1.5.2.5)	which is a combination of the foregoing or is produced by other means	V
1.6)		Cases not covered above, in which an emission consists of the main carrier modulated, either simultaneously or in a pre-established sequence, in a combination of two or more of the following modes: amplitude, angle, pulse	W
1.7)		Cases not otherwise covered	X
	2)	<i>Second symbol</i> – Nature of signal(s) modulating the main carrier	
2.1)		No modulating signal	0
2.2)		A single channel containing quantized or digital information without the use of a modulating sub-carrier <sup>3</sup>	1
2.3)		A single channel containing quantized or digital information with the use of a modulating sub-carrier <sup>3</sup>	2
2.4)		A single channel containing analogue information	3
2.5)		Two or more channels containing quantized or digital information	7
2.6)		Two or more channels containing analogue information	8
2.7)		Composite system with one or more channels containing quantized or digital information, together with one or more channels containing analogue information	9
2.8)		Cases not otherwise covered	X
	3)	<i>Third symbol</i> – Type of information to be transmitted <sup>4</sup>	
3.1)		No information transmitted	N
3.2)		Telegraphy – for aural reception	A
3.3)		Telegraphy – for automatic reception	B
3.4)		Facsimile	C
3.5)		Data transmission, telemetry, telecommand	D
3.6)		Telephony (including sound broadcasting)	E
3.7)		Television (video)	F
3.8)		Combination of the above	W
3.9)		Cases not otherwise covered	X

---

<sup>3</sup> This excludes time-division multiplex.

<sup>4</sup> In this context the word “information” does not include information of a constant, unvarying nature such as is provided by standard frequency emissions, continuous wave and pulse radars, etc.

**Sub-Section IIB – Optional characteristics for the classification of emissions**

§ 7 Two optional characteristics should be added for a more complete description of an emission. These are:

*Fourth symbol* – Details of signal(s)

*Fifth symbol* – Nature of multiplexing

Where the fourth or fifth symbol is used it shall be as indicated below.

Where the fourth or the fifth symbol is not used this should be indicated by a dash where each symbol would otherwise appear.

1) *Fourth symbol* – Details of signal(s)

1.1)	Two-condition code with elements of differing numbers and/or durations	A
1.2)	Two-condition code with elements of the same number and duration without error-correction	B
1.3)	Two-condition code with elements of the same number and duration with error-correction	C
1.4)	Four-condition code in which each condition represents a signal element (or one or more bits)	D
1.5)	Multi-condition code in which each condition represents a signal element (of one or more bits)	E
1.6)	Multi-condition code in which each condition or combination of conditions represents a character	F
1.7)	Sound of broadcasting quality (monophonic)	G
1.8)	Sound of broadcasting quality (stereophonic or quadraphonic)	H
1.9)	Sound of commercial quality (excluding categories given in § 1.10) and 1.11))	J
1.10)	Sound of commercial quality with the use of frequency inversion or band-splitting	K
1.11)	Sound of commercial quality with separate frequency-modulated signals to control the level of demodulated signal	L
1.12)	Monochrome	M
1.13)	Colour	N
1.14)	Combination of the above	W
1.15)	Cases not otherwise covered	X

	2) <i>Fifth symbol</i> – Nature of multiplexing	
2.1)	None	N
2.2)	Code-division multiplex <sup>5</sup>	C
2.3)	Frequency-division multiplex	F
2.4)	Time-division multiplex	T
2.5)	Combination of frequency-division multiplex and time-division multiplex	W
2.6)	Other types of multiplexing	X

---

<sup>5</sup> This includes bandwidth expansion techniques.



## APPENDIX 2 (REV.WRC-03)

**Table of transmitter frequency tolerances**

(See Article 3)

1 Frequency tolerance is defined in Article 1 and is expressed in parts in  $10^6$ , unless otherwise indicated.

2 The power shown for the various categories of stations is the peak envelope power for single-sideband transmitters and the mean power for all other transmitters, unless otherwise indicated. The term “power of a radio transmitter” is defined in Article 1.

3 For technical and operational reasons, certain categories of stations may need more stringent tolerances than those shown in the table.

Frequency bands (lower limit exclusive, upper limit inclusive) and categories of stations	Tolerances applicable to transmitters
<b>Band: 9 kHz to 535 kHz</b> 1 <i>Fixed stations:</i> – 9 kHz to 50 kHz – 50 kHz to 535 kHz 2 <i>Land stations:</i> a) Coast stations b) Aeronautical stations 3 <i>Mobile stations:</i> a) Ship stations b) Ship’s emergency transmitters c) Survival craft stations d) Aircraft stations 4 <i>Radiodetermination stations</i> 5 <i>Broadcasting stations</i>	100 50 100 1,2 100 200 3,4 500 5 500 100 100 10 Hz
<b>Band: 535 kHz to 1 606.5 kHz (1 605 kHz in Region 2)</b> <i>Broadcasting stations</i>	10 Hz (WRC-03)
<b>Band: 1 606.5 kHz (1 605 kHz in Region 2) to 4 000 kHz</b> 1 <i>Fixed stations:</i> – power 200 W or less – power above 200 W 2 <i>Land stations:</i> – power 200 W or less – power above 200 W	100 7,8 50 7,8 100 1,2,7,9,10 50 1,2,7,9,10

<p style="text-align: center;"><b>Frequency bands (lower limit exclusive, upper limit inclusive) and categories of stations</b></p>	<p style="text-align: center;"><b>Tolerances applicable to transmitters</b></p>
<p><i>Band: 1 606.5 kHz (1 605 kHz in Region 2) to 4 000 kHz (cont.)</i></p> <p>3 <i>Mobile stations:</i></p> <p>a) Ship stations</p> <p>b) Survival craft stations</p> <p>c) Emergency position-indicating radiobeacons</p> <p>d) Aircraft stations</p> <p>e) Land mobile stations</p> <p>4 <i>Radiodetermination stations:</i></p> <p>– power 200 W or less</p> <p>– power above 200 W</p> <p>5 <i>Broadcasting stations</i></p>	<p>40 Hz <sup>3, 4, 12</sup></p> <p>100</p> <p>100</p> <p>100 <sup>10</sup></p> <p>50 <sup>13</sup></p> <p>20 <sup>14</sup></p> <p>10 <sup>14</sup></p> <p>10 Hz <sup>15</sup></p>
<p><i>Band: 4 MHz to 29.7 MHz</i></p> <p>1 <i>Fixed stations:</i></p> <p>a) Single-sideband and independent-sideband emissions:</p> <p>– power 500 W or less</p> <p>– power above 500 W</p> <p>b) Class F1B emissions</p> <p>c) Other classes of emission:</p> <p>– power 500 W or less</p> <p>– power above 500 W</p> <p>2 <i>Land stations:</i></p> <p>a) Coast stations</p> <p>b) Aeronautical stations:</p> <p>– power 500 W or less</p> <p>– power above 500 W</p> <p>c) Base stations</p> <p>3 <i>Mobile stations:</i></p> <p>a) Ship stations:</p> <p>1) Class A1A emissions</p> <p>2) Emissions other than Class A1A</p> <p>b) Survival craft stations</p> <p>c) Aircraft stations</p> <p>d) Land mobile stations</p> <p>4 <i>Broadcasting stations</i></p> <p>5 <i>Space stations</i></p> <p>6 <i>Earth stations</i></p>	<p>50 Hz</p> <p>20 Hz</p> <p>10 Hz</p> <p>20</p> <p>10</p> <p>20 Hz <sup>1, 2, 16</sup></p> <p>100 <sup>10</sup></p> <p>50 <sup>10</sup></p> <p>20 <sup>7</sup></p> <p>10</p> <p>50 Hz <sup>3, 4, 19</sup></p> <p>50</p> <p>100 <sup>10</sup></p> <p>40 <sup>20</sup></p> <p>10 Hz <sup>15, 21</sup></p> <p>20</p> <p>20</p>

Frequency bands (lower limit exclusive, upper limit inclusive) and categories of stations	Tolerances applicable to transmitters
<p><b>Band: 29.7 MHz to 100 MHz</b></p> <p>1 <i>Fixed stations:</i></p> <ul style="list-style-type: none"> <li>– power 50 W or less</li> <li>– power above 50 W</li> </ul> <p>2 <i>Land stations</i></p> <p>3 <i>Mobile stations</i></p> <p>4 <i>Radiodetermination stations</i></p> <p>5 <i>Broadcasting stations (other than television)</i></p> <p>6 <i>Broadcasting stations (television sound and vision)</i></p> <p>7 <i>Space stations</i></p> <p>8 <i>Earth stations</i></p>	<p>30</p> <p>20</p> <p>20</p> <p>20<sup>22</sup></p> <p>50</p> <p>2 000 Hz<sup>23</sup></p> <p>500 Hz<sup>24, 25</sup></p> <p>20</p> <p>20</p>
<p><b>Band: 100 MHz to 470 MHz</b></p> <p>1 <i>Fixed stations:</i></p> <ul style="list-style-type: none"> <li>– power 50 W or less</li> <li>– power above 50 W</li> </ul> <p>2 <i>Land stations:</i></p> <ul style="list-style-type: none"> <li>a) <i>Coast stations</i></li> <li>b) <i>Aeronautical stations</i></li> <li>c) <i>Base stations:</i> <ul style="list-style-type: none"> <li>– in the band 100-235 MHz</li> <li>– in the band 235-401 MHz</li> <li>– in the band 401-470 MHz</li> </ul> </li> </ul> <p>3 <i>Mobile stations:</i></p> <ul style="list-style-type: none"> <li>a) <i>Ship stations and survival craft stations:</i> <ul style="list-style-type: none"> <li>– in the band 156-174 MHz</li> <li>– outside the band 156-174 MHz</li> </ul> </li> <li>b) <i>Aircraft stations</i></li> <li>c) <i>Land mobile stations:</i> <ul style="list-style-type: none"> <li>– in the band 100-235 MHz</li> <li>– in the band 235-401 MHz</li> <li>– in the band 401-470 MHz</li> </ul> </li> </ul> <p>4 <i>Radiodetermination stations</i></p> <p>5 <i>Broadcasting stations (other than television)</i></p> <p>6 <i>Broadcasting stations (television sound and vision)</i></p> <p>7 <i>Space stations</i></p> <p>8 <i>Earth stations</i></p>	<p>20<sup>26</sup></p> <p>10</p> <p>10</p> <p>20<sup>28</sup></p> <p>15<sup>29</sup></p> <p>7<sup>29</sup></p> <p>5<sup>29</sup></p> <p>10</p> <p>50<sup>31</sup></p> <p>30<sup>28</sup></p> <p>15<sup>29</sup></p> <p>7<sup>29, 32</sup></p> <p>5<sup>29, 32</sup></p> <p>50<sup>33</sup></p> <p>2 000 Hz<sup>23</sup></p> <p>500 Hz<sup>24, 25</sup></p> <p>20</p> <p>20</p>



<p style="text-align: center;"><b>Frequency bands (lower limit exclusive, upper limit inclusive) and categories of stations</b></p>	<p style="text-align: center;"><b>Tolerances applicable to transmitters</b></p>
<p><b>Band: 470 MHz to 2 450 MHz</b></p> <p>1 <i>Fixed stations:</i></p> <ul style="list-style-type: none"> <li>– power 100 W or less</li> <li>– power above 100 W</li> </ul> <p>2 <i>Land stations</i></p> <p>3 <i>Mobile stations</i></p> <p>4 <i>Radiodetermination stations</i></p> <p>5 <i>Broadcasting stations (other than television)</i></p> <p>6 <i>Broadcasting stations (television sound and vision) in the band 470 MHz to 960 MHz</i></p> <p>7 <i>Space stations</i></p> <p>8 <i>Earth stations</i></p>	<p>100</p> <p>50</p> <p>20 <sup>36</sup></p> <p>20 <sup>36</sup></p> <p>500 <sup>33</sup></p> <p>100</p> <p>500 Hz <sup>24, 25</sup></p> <p>20</p> <p>20</p>
<p><b>Band: 2 450 MHz to 10 500 MHz</b></p> <p>1 <i>Fixed stations:</i></p> <ul style="list-style-type: none"> <li>– power 100 W or less</li> <li>– power above 100 W</li> </ul> <p>2 <i>Land stations</i></p> <p>3 <i>Mobile stations</i></p> <p>4 <i>Radiodetermination stations</i></p> <p>5 <i>Space stations</i></p> <p>6 <i>Earth stations</i></p>	<p>200</p> <p>50</p> <p>100</p> <p>100</p> <p>100</p> <p>1 250 <sup>33</sup></p> <p>50</p> <p>50</p>
<p><b>Band: 10.5 GHz to 40 GHz</b></p> <p>1 <i>Fixed station</i></p> <p>2 <i>Radiodetermination stations</i></p> <p>3 <i>Broadcasting stations</i></p> <p>4 <i>Space stations</i></p> <p>5 <i>Earth stations</i></p>	<p>300</p> <p>5 000 <sup>33</sup></p> <p>100</p> <p>100</p> <p>100</p>

**Notes in the table of transmitter frequency tolerances**

- <sup>1</sup> For coast station transmitters used for direct-printing telegraphy or for data transmission, the tolerance is:
- 5 Hz for narrow-band phase-shift keying;
  - 15 Hz for frequency-shift keying for transmitters in use or installed before 2 January 1992;
  - 10 Hz for frequency-shift keying for transmitters installed after 1 January 1992.
- <sup>2</sup> For coast station transmitters used for digital selective calling, the tolerance is 10 Hz. (WRC-03)
- <sup>3</sup> For ship station transmitters used for direct-printing telegraphy or for data transmission, the tolerance is:
- 5 Hz for narrow-band phase-shift keying;
  - 40 Hz for frequency-shift keying for transmitters in use or installed before 2 January 1992;
  - 10 Hz for frequency-shift keying for transmitters installed after 1 January 1992.
- <sup>4</sup> For ship station transmitters used for digital selective calling, the tolerance is 10 Hz. (WRC-03)
- <sup>5</sup> If the emergency transmitter is used as the reserve transmitter for the main transmitter, the tolerance for ship station transmitters applies.
- <sup>6</sup> (SUP - WRC-03)
- <sup>7</sup> For single-sideband radiotelephone transmitters except at coast stations, the tolerance is:
- 50 Hz in the bands 1 606.5 (1 605 Region 2)-4 000 kHz and 4-29.7 MHz, for peak envelope powers of 200 W or less and 500 W or less, respectively;
  - 20 Hz in the bands 1 606.5 (1 605 Region 2)-4 000 kHz and 4-29.7 MHz, for peak envelope powers above 200 W and 500 W, respectively.
- <sup>8</sup> For radiotelegraphy transmitters with frequency-shift keying the tolerance is 10 Hz.
- <sup>9</sup> For coast station single-sideband radiotelephone transmitters the tolerance is 20 Hz.
- <sup>10</sup> For single-sideband transmitters operating in the frequency bands 1 606.5 (1 605 Region 2)-4 000 kHz and 4-29.7 MHz which are allocated exclusively to the aeronautical mobile (R) service, the tolerance on the carrier (reference) frequency is:
- a) for all aeronautical stations, 10 Hz;
  - b) for all aircraft stations operating on international services, 20 Hz;
  - c) for aircraft stations operating exclusively on national services, 50 Hz\*.
- <sup>11</sup> Not used.
- <sup>12</sup> For A1A emissions the tolerance is  $50 \times 10^{-6}$ .
- <sup>13</sup> For transmitters used for single-sideband radiotelephony or for frequency-shift keying radiotelegraphy the tolerance is 40 Hz.
- <sup>14</sup> For radiobeacon transmitters in the band 1 606.5 (1 605 Region 2)-1 800 kHz the tolerance is  $50 \times 10^{-6}$ .

---

\* NOTE – In order to achieve maximum intelligibility, it is suggested that administrations encourage the reduction of this tolerance to 20 Hz.

## AP2-6

- <sup>15</sup> For A3E emissions with carrier power of 10 kW or less the tolerance is  $20 \times 10^{-6}$ ,  $15 \times 10^{-6}$  and  $10 \times 10^{-6}$  in the bands 1 606.5 (1 605 Region 2)-4 000 kHz, 4-5.95 MHz and 5.95-29.7 MHz respectively.
- <sup>16</sup> For A1A emissions the tolerance is  $10 \times 10^{-6}$ .
- <sup>17</sup> Not used.
- <sup>18</sup> Not used.
- <sup>19</sup> For ship station transmitters in the band 26 175-27 500 kHz, on board small craft, with a carrier power not exceeding 5 W in or near coastal waters and utilizing F3E and G3E emissions, the frequency tolerance is  $40 \times 10^{-6}$ . (WRC-03)
- <sup>20</sup> The tolerance is 50 Hz for single-sideband radiotelephone transmitters, except for those transmitters operating in the band 26 175-27 500 kHz, and not exceeding a peak envelope power of 15 W, for which the basic tolerance of  $40 \times 10^{-6}$  applies.
- <sup>21</sup> It is suggested that administrations avoid carrier frequency differences of a few hertz, which cause degradations similar to periodic fading. This could be avoided if the frequency tolerance were 0.1 Hz, a tolerance which would be suitable for single-sideband emissions\*.
- <sup>22</sup> For non-vehicular mounted portable equipment with a transmitter mean power not exceeding 5 W, the tolerance is  $40 \times 10^{-6}$ .
- <sup>23</sup> For transmitters of a mean power of 50 W or less operating at frequencies below 108 MHz a tolerance of 3 000 Hz applies.
- <sup>24</sup> In the case of television stations of:
- 50 W (vision peak envelope power) or less in the band 29.7-100 MHz;
  - 100 W (vision peak envelope power) or less in the band 100-960 MHz;
- and which receive their input from other television stations or which serve small isolated communities, it may not, for operational reasons, be possible to maintain this tolerance. For such stations, the tolerance is 2 000 Hz.
- For stations of 1 W (vision peak envelope power) or less, this tolerance may be relaxed further to:
- 5 kHz in the band 100-470 MHz;
  - 10 kHz in the band 470-960 MHz.
- <sup>25</sup> For transmitters for system M (NTSC) the tolerance is 1 000 Hz. However, for low power transmitters using this system Note 24 applies.
- <sup>26</sup> For multi-hop radio-relay systems employing direct frequency conversion the tolerance is  $30 \times 10^{-6}$ .
- <sup>27</sup> Not used.
- <sup>28</sup> For a channel spacing of 50 kHz the tolerance is  $50 \times 10^{-6}$ .
- <sup>29</sup> These tolerances apply to channel spacings equal to or greater than 20 kHz.

---

\* NOTE – The single-sideband system adopted for the bands exclusively allocated to HF broadcasting does not require a frequency tolerance less than 10 Hz. The above-mentioned degradation occurs when the ratio of wanted-to-interfering signal is well below the required protection ratio. This remark is equally valid for both double- and single-sideband emissions.

- <sup>30</sup> Not used.
- <sup>31</sup> For transmitters used by on-board communication stations a tolerance of  $5 \times 10^{-6}$  shall apply.
- <sup>32</sup> For non-vehicular mounted portable equipment with a transmitter mean power not exceeding 5 W the tolerance is  $15 \times 10^{-6}$ .
- <sup>33</sup> Where specific frequencies are not assigned to radar stations, the bandwidth occupied by the emissions of such stations shall be maintained wholly within the band allocated to the service and the indicated tolerance does not apply.
- <sup>34</sup> Not used.
- <sup>35</sup> Not used.
- <sup>36</sup> In applying this tolerance administrations should be guided by the latest relevant ITU-R Recommendations.



## APPENDIX 3 (REV.WRC-12)

**Maximum permitted power levels for unwanted emissions  
in the spurious domain** (WRC-12)

(See Article 3)

1 This Appendix derived indicates the maximum permitted power levels of unwanted emissions in the spurious domain using the values indicated in Table I. The provisions of No. 4.5 apply to unwanted emissions not covered in this Appendix. (WRC-12)

2 Spurious domain emissions<sup>1</sup> from any part of the installation, other than the antenna and its transmission line, shall not have an effect greater than would occur if this antenna system were supplied with the maximum permitted power at the frequency of that emission. (WRC-12)

3 These levels shall not, however, apply to emergency position-indicating radiobeacon (EPIRB) stations, emergency locator transmitters, ships' emergency transmitters, lifeboat transmitters, survival craft stations or maritime transmitters when used in emergency situations.

4 For technical or operational reasons, more stringent levels than those specified may be applied to protect specific services in certain frequency bands. The levels applied to protect these services, such as safety and passive services, shall be those agreed upon by the appropriate world radiocommunication conference. More stringent levels may also be fixed by specific agreement between the administrations concerned. Additionally, special consideration of transmitter spurious domain emissions may be required for the protection of safety services, radio astronomy and space services using passive sensors. Information on the levels of interference detrimental to radio astronomy, Earth exploration satellites and meteorological passive sensing is given in the most recent version of Recommendation ITU-R SM.329. (WRC-12)

5 Spurious domain emission limits for combined radiocommunication and information technology equipment are those for the radiocommunication transmitters. (WRC-12)

6 The frequency range of the measurement of spurious domain emissions is from 9 kHz to 110 GHz or the second harmonic if higher. (WRC-03)

---

<sup>1</sup> Spurious domain emissions are unwanted emissions at frequencies within the spurious domain.

## AP3-2

7 Except as provided in § 8 and 9 of this Appendix, the spurious domain emission levels are specified in the following reference bandwidths:

- 1 kHz between 9 kHz and 150 kHz
- 10 kHz between 150 kHz and 30 MHz
- 100 kHz between 30 MHz and 1 GHz
- 1 MHz above 1 GHz. (WRC-03)

8 The reference bandwidth of all space service spurious domain emissions should be 4 kHz. (WRC-03)

9 For radar systems, the reference bandwidths for specifying spurious domain emission levels should be calculated for each particular system. Thus, for the four general types of radar pulse modulation utilized for radionavigation, radiolocation, acquisition, tracking and other radiodetermination functions, the reference bandwidth values are determined using the following:

- for a fixed-frequency, non-pulse-coded radar, the reciprocal of the radar pulse length, in seconds (e.g. if the radar pulse length is 1  $\mu$ s, then the reference bandwidth is  $1/(1 \mu\text{s}) = 1 \text{ MHz}$ );
- for a fixed-frequency, phase-coded pulsed radar, the reciprocal of the phase chip length, in seconds (e.g. if the phase-coded chip is 2  $\mu$ s long, then the reference bandwidth is  $1/(2 \mu\text{s}) = 500 \text{ kHz}$ );
- for a frequency modulated (FM) or chirped radar, the square root of the quantity obtained by dividing the chirp bandwidth in MHz by the pulse length, in  $\mu$ s (e.g. if the FM is from 1 250 MHz to 1 280 MHz, i.e. 30 MHz, during the pulse length of 10  $\mu$ s, then the reference bandwidth is  $(30 \text{ MHz}/10 \mu\text{s})^{1/2} = 1.73 \text{ MHz}$ );
- for radars operating with multiple waveforms, the reference bandwidth for specifying spurious domain emission levels is determined empirically from observations of the radar emission and is obtained following the guidance given in the most recent version of Recommendation ITU-R M.1177.

In the case of radars, for which the bandwidth, as determined using the method above, is greater than 1 MHz, a reference bandwidth of 1 MHz should be used. (WRC-03)

10 Guidance regarding the methods of measuring spurious domain emissions is given in the most recent version of Recommendation ITU-R SM.329. The e.i.r.p. method specified in this Recommendation should be used when it is not possible to accurately measure the power supplied to the antenna transmission line, or for specific applications where the antenna is designed to provide significant attenuation in the spurious domain. Additionally, the e.i.r.p. method may need some modification for special cases. Specific guidance regarding the methods of measuring spurious domain emissions from radar systems is given in the most recent version of Recommendation ITU-R M.1177.

To improve measurement accuracy, sensitivity and efficiency, the resolution bandwidth in which spurious domain emissions are measured can be different from the reference bandwidth used for specifying spurious domain emission levels. (WRC-03)

11 The emission limits of this Appendix apply to all emissions, including harmonic emissions, intermodulation products, frequency conversion products and parasitic emissions, at frequencies in the spurious domain (see Fig. 1). The upper and lower parts of the spurious domain extend outward from a boundary determined using Annex 1. (WRC-03)

FIGURE 1 (WRC-03)  
**Out-of-band and spurious domains**

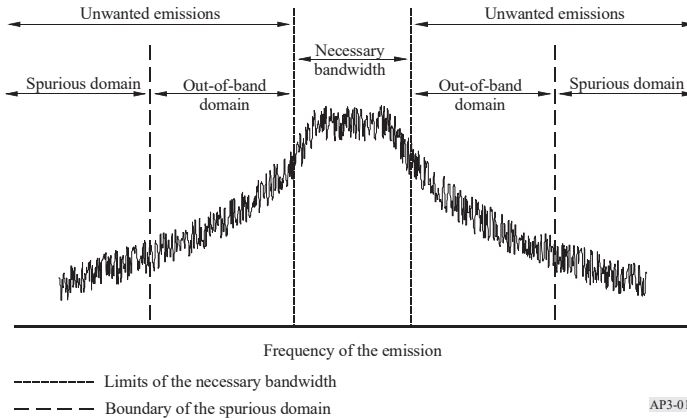

12 For the case of a single satellite operating with more than one transponder in the same service area, and when considering the limits for spurious domain emissions as indicated in § 11 of this Appendix, spurious domain emissions from one transponder may fall on a frequency at which a second, companion transponder is transmitting. In these situations, the level of spurious domain emissions from the first transponder is well exceeded by the fundamental or out-of-band domain emissions of the second transponder. Therefore, the limits of this Appendix should not apply to those emissions of a satellite that fall within either the necessary bandwidth or the out-of-band domain of another transponder on the same satellite, in the same service area (see Fig. 2). (WRC-03)

FIGURE 2  
**Example of the applicability of spurious domain emission limits to a satellite transponder**

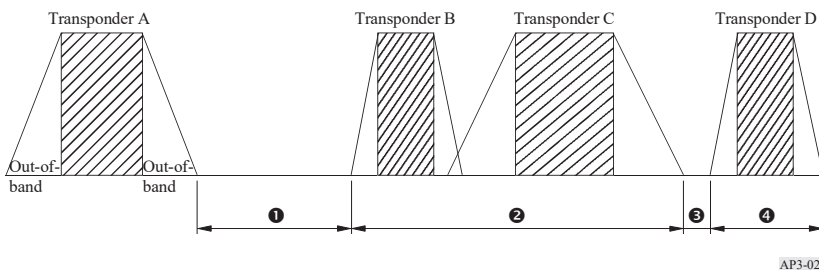



Transponders A, B, C and D are operating on the same satellite in the same service area. Transponder A is not required to meet spurious domain emission limits in frequency ranges ② and ④, but is required to meet them in frequency ranges ① and ③. (WRC-03)

### 13 Examples of applying $43 + 10 \log (P)$ to calculate attenuation requirements

Where specified in relation to mean power, spurious domain emissions are to be at least  $x$  dB below the total mean power  $P$ , i.e.  $-x$  dBc. The power  $P$  (W) is to be measured in a bandwidth wide enough to include the total mean power. The spurious domain emissions are to be measured in the reference bandwidths given in the relevant ITU-R Recommendations. The measurement of the spurious domain emission power is independent of the value of necessary bandwidth. Because the absolute emission power limit, derived from  $43 + 10 \log (P)$ , can become too stringent for high-power transmitters, alternative relative powers are also provided in Table I.

#### *Example 1*

A land mobile transmitter, with any value of necessary bandwidth, must meet a spurious domain emission attenuation of  $43 + 10 \log (P)$ , or 70 dBc, whichever is less stringent. The reference bandwidths used for specifying spurious domain emission levels are provided in § 8 to 10 of this Appendix. Applying this in the frequency range between 30 MHz and 1 GHz gives a reference bandwidth of 100 kHz.

With a measured total mean power of 10 W:

- Attenuation relative to total mean power =  $43 + 10 \log (10) = 53$  dBc.
- The 53 dBc value is less stringent than the 70 dBc, so the 53 dBc value is used.
- Therefore: Spurious domain emissions must not exceed 53 dBc in a 100 kHz bandwidth, or converting to an absolute level, they must not exceed  $10 \text{ dBW} - 53 \text{ dBc} = -43 \text{ dBW}$  in a 100 kHz reference bandwidth.

With a measured total mean power of 1 000 W:

- Attenuation relative to total mean power =  $43 + 10 \log (1\ 000) = 73$  dBc.
- The 73 dBc value is more stringent than the 70 dBc limit, so the 70 dBc value is used.
- Therefore: Spurious domain emissions must not exceed 70 dBc in a 100 kHz bandwidth, or converting to an absolute level, they must not exceed  $30 \text{ dBW} - 70 \text{ dBc} = -40 \text{ dBW}$  in a 100 kHz reference bandwidth. (WRC-03)

*Example 2*

A space service transmitter with any value of necessary bandwidth must meet a spurious domain emission attenuation of  $43 + 10 \log (P)$ , or 60 dBc, whichever is less stringent. To measure spurious domain emissions at any frequency, Note 10 to Table I indicates using a reference bandwidth of 4 kHz.

With a measured total mean power of 20 W:

- Attenuation relative to total mean power =  $43 + 10 \log (20) = 56$  dBc.
- The 56 dBc value is less stringent than the 60 dBc limit, so the 56 dBc value is used.
- Therefore: Spurious domain emissions must not exceed 56 dBc in a 4 kHz reference bandwidth, or converting to an absolute level, they must not exceed  $13 \text{ dBW} - 56 \text{ dBc} = -43 \text{ dBW}$  in a 4 kHz reference bandwidth. (WRC-03)

TABLE I (WRC-12)

**Attenuation values used to calculate maximum permitted  
spurious domain emission power levels for  
use with radio equipment**

Service category in accordance with Article 1, or equipment type <sup>15</sup>	Attenuation (dB) below the power supplied to the antenna transmission line
All services except those services quoted below:	$43 + 10 \log (P)$ , or 70 dBc, whichever is less stringent
Space services (earth stations) <sup>10, 16</sup>	$43 + 10 \log (P)$ , or 60 dBc, whichever is less stringent
Space services (space stations) <sup>10, 17</sup>	$43 + 10 \log (P)$ , or 60 dBc, whichever is less stringent
Radiodetermination <sup>14</sup>	$43 + 10 \log (PEP)$ , or 60 dB, whichever is less stringent
Broadcast television <sup>11</sup>	$46 + 10 \log (P)$ , or 60 dBc, whichever is less stringent, without exceeding the absolute mean power level of 1 mW for VHF stations or 12 mW for UHF stations. However, greater attenuation may be necessary on a case by case basis
Broadcast FM	$46 + 10 \log (P)$ , or 70 dBc, whichever is less stringent; the absolute mean power level of 1 mW should not be exceeded
Broadcasting at MF/HF	50 dBc; the absolute mean power level of 50 mW should not be exceeded
SSB from mobile stations <sup>12</sup>	43 dB below <i>PEP</i>
Amateur services operating below 30 MHz (including those using SSB) <sup>16</sup>	$43 + 10 \log (PEP)$ , or 50 dB, whichever is less stringent

TABLE I (end) (WRC-12)

Service category in accordance with Article 1, or equipment type <sup>15</sup>	Attenuation (dB) below the power supplied to the antenna transmission line
Services operating below 30 MHz, except space, radiodetermination, broadcast, those using SSB from mobile stations, and amateur <sup>12</sup>	43 + 10 log ( $X$ ), or 60 dBc, whichever is less stringent, where $X = PEP$ for SSB modulation, and $X = P$ for other modulation
Low-power device radio equipment <sup>13</sup>	56 + 10 log ( $P$ ), or 40 dBc, whichever is less stringent
Emergency transmitters <sup>18</sup>	No limit

*P*: mean power in watts supplied to the antenna transmission line, in accordance with No. **1.158**. When burst transmission is used, the mean power  $P$  and the mean power of any spurious domain emissions are measured using power averaging over the burst duration.

*PEP*: peak envelope power in watts supplied to the antenna transmission line, in accordance with No. **1.157**.

dBc: decibels relative to the unmodulated carrier power of the emission. In the cases which do not have a carrier, for example in some digital modulation schemes where the carrier is not accessible for measurement, the reference level equivalent to dBc is decibels relative to the mean power  $P$ .

<sup>10</sup> Spurious domain emission limits for all space services are stated in a 4 kHz reference bandwidth.

<sup>11</sup> For analogue television transmissions, the mean power level is defined with a specified video signal modulation. This video signal has to be chosen in such a way that the maximum mean power level (e.g. at the video signal blanking level for negatively modulated television systems) is supplied to the antenna transmission line.

<sup>12</sup> All classes of emission using SSB are included in the category “SSB”.

<sup>13</sup> Low-power radio devices having a maximum output power of less than 100 mW and intended for short-range communication or control purposes; such equipment is in general exempt from individual licensing.

<sup>14</sup> For radiodetermination systems (radar as defined by No. **1.100**), spurious domain emission attenuation (dB) shall be determined for radiated emission levels, and not at the antenna transmission line. The measurement methods for determining the radiated spurious domain emission levels from radar systems should be guided by the most recent version of Recommendation ITU-R M.1177. (WRC-03)

<sup>15</sup> In some cases of digital modulation (including digital broadcasting), broadband systems, pulsed modulation and narrow-band high-power transmitters for all categories of services, there may be difficulties in meeting limits close to  $\pm 250\%$  of the necessary bandwidth.

<sup>16</sup> Earth stations in the amateur-satellite service operating below 30 MHz are in the service category “Amateur services operating below 30 MHz (including those using SSB)”. (WRC-2000)

<sup>17</sup> Space stations in the space research service intended for operation in deep space as defined by No. **1.177** are exempt from spurious domain emission limits. (WRC-03)

<sup>18</sup> Emergency position-indicating radio beacon, emergency locator transmitters, personal location beacons, search and rescue transponders, ship emergency, lifeboat and survival craft transmitters and emergency land, aeronautical or maritime transmitters. (WRC-2000)

## ANNEX 1 (WRC-03)

### Determination of the boundary between the out-of-band and spurious domains

1 Except as provided below, the boundary between the out-of-band and spurious domains occurs at frequencies that are separated from the centre frequency of the emission by the values shown in Table 1. In general, the boundary, on either side of the centre frequency, occurs at a separation of 250% of the necessary bandwidth, or at  $2.5 B_N$ , as shown in Table 1. For most systems, the centre frequency of the emission is the centre of the necessary bandwidth. For multichannel or multicarrier transmitters/transponders, where several carriers may be transmitted simultaneously from a final output amplifier or an active antenna, the centre frequency of the emission is taken to be the centre of the  $-3$  dB bandwidth of the transmitter or transponder, and the transmitter or transponder bandwidth is used in place of the necessary bandwidth for determining the boundary. For multicarrier satellite systems, guidance on the boundary between the out-of-band and spurious domains is provided in the most recent version of Recommendation ITU-R SM.1541. Some systems specify unwanted emissions relative to channel bandwidth, or channel spacing. These may be used as a substitute for the necessary bandwidth in Table 1, provided they are found in ITU-R Recommendations.

TABLE 1

**Values for frequency separation between the centre frequency and the boundary of the spurious domain**

Frequency range	Narrow-band case		Normal separation	Wideband case	
	for $B_N <$	Separation		for $B_N >$	Separation
9 kHz $< f_c \leq$ 150 kHz	250 Hz	625 Hz	$2.5 B_N$	10 kHz	$1.5 B_N + 10$ kHz
150 kHz $< f_c \leq$ 30 MHz	4 kHz	10 kHz	$2.5 B_N$	100 kHz	$1.5 B_N + 100$ kHz
30 MHz $< f_c \leq$ 1 GHz	25 kHz	62.5 kHz	$2.5 B_N$	10 MHz	$1.5 B_N + 10$ MHz
1 GHz $< f_c \leq$ 3 GHz	100 kHz	250 kHz	$2.5 B_N$	50 MHz	$1.5 B_N + 50$ MHz
3 GHz $< f_c \leq$ 10 GHz	100 kHz	250 kHz	$2.5 B_N$	100 MHz	$1.5 B_N + 100$ MHz
10 GHz $< f_c \leq$ 15 GHz	300 kHz	750 kHz	$2.5 B_N$	250 MHz	$1.5 B_N + 250$ MHz
15 GHz $< f_c \leq$ 26 GHz	500 kHz	1.25 MHz	$2.5 B_N$	500 MHz	$1.5 B_N + 500$ MHz
$f_c >$ 26 GHz	1 MHz	2.5 MHz	$2.5 B_N$	500 MHz	$1.5 B_N + 500$ MHz

NOTE – In Table 1,  $f_c$  is the centre frequency of the emission and  $B_N$  is the necessary bandwidth. If the assigned frequency band of the emissions extends across two frequency ranges, then the values corresponding to the higher frequency range shall be used for determining the boundary.

*Example 1:* The necessary bandwidth of an emission at 26 MHz is 1.8 kHz. Since  $B_N$  is less than 4 kHz, the minimum separation of 10 kHz applies. The spurious domain begins 10 kHz each side of the centre of the necessary bandwidth.

*Example 2:* The necessary bandwidth of an emission at 8 GHz is 200 MHz. Since the wideband case applies for  $B_N > 100$  MHz at that frequency, the spurious domain begins  $1.5 \times 200$  MHz + 100 MHz = 400 MHz each side of the centre of the necessary bandwidth. Using the general separation formula, the out-of-band domain would have extended to  $2.5 \times 200$  MHz = 500 MHz either side of the centre frequency.

2 Tables 2 and 3 show exceptions to Table 1 for narrow-band and wideband cases, respectively, applicable to particular systems or services and frequency bands.

TABLE 2

**Narrow-band variations for particular systems or services and frequency bands**

System or service	Frequency range		Narrow-band case	
			for $B_N <$ (kHz)	Separation (kHz)
Fixed service	14 kHz-1.5 MHz		20	50 <sup>(1)</sup>
	1.5-30 MHz	$P_T \leq 50$ W	30	75 <sup>(2)</sup>
		$P_T > 50$ W	80	200 <sup>(2)</sup>

<sup>(1)</sup> The separation value is based on an assumption that the maximum value of the necessary bandwidth is about 3 kHz for the frequency range 14 kHz-1.5 MHz. The separation value of 50 kHz is extremely large as compared with the necessary bandwidth. This is because unwanted emissions of high power transmitters under modulated conditions have to be below the spurious limit (70 dBc) at the boundary between the out-of-band and spurious domains.

<sup>(2)</sup>  $P_T$  is the transmitter power. The separation values are based on an assumption that the maximum value of the necessary bandwidth is about 12 kHz for the frequency range 1.5-30 MHz. The separation value of 200 kHz for  $P_T > 50$  W is extremely large as compared with the necessary bandwidth. This is because unwanted emissions of high power transmitters under modulated conditions have to be below the spurious limit, 70 dBc, at the boundary between the out-of-band and spurious domains. Also, if future systems in the fixed service operating in this frequency range require a necessary bandwidth larger than 12 kHz, it may become necessary to review the 200 kHz separation.

TABLE 3

## Wideband variations for particular systems or services and frequency bands

System or service	Frequency range	Wideband case	
		For $B_N >$	Separation
Fixed service	14-150 kHz	20 kHz	$1.5 B_N + 20$ kHz
Fixed-satellite service (FSS)	3.4-4.2 GHz	250 MHz	$1.5 B_N + 250$ MHz
FSS	5.725-6.725 GHz	500 MHz	$1.5 B_N + 500$ MHz
FSS	7.25-7.75 GHz and 7.9-8.4 GHz	250 MHz	$1.5 B_N + 250$ MHz
FSS	10.7-12.75 GHz	500 MHz	$1.5 B_N + 500$ MHz
Broadcasting-satellite service	11.7-12.75 GHz	500 MHz	$1.5 B_N + 500$ MHz
FSS	12.75-13.25 GHz	500 MHz	$1.5 B_N + 500$ MHz
FSS	13.75-14.8 GHz	500 MHz	$1.5 B_N + 500$ MHz

3 For primary radar, the boundary between the out-of-band and spurious domains is the frequency at which the out-of-band domain limits specified in the applicable ITU-R Recommendations are equal to the spurious domain limit defined in Table I of this Appendix. Further guidance on the boundary between the out-of-band and spurious domains for primary radar is provided in the most recent version of Recommendation ITU-R SM.1541.



## APPENDIX 4 (REV.WRC-19)

**Consolidated list and tables of characteristics for use in the  
application of the procedures of Chapter III**

1 The substance of this Appendix is separated into two parts: one concerning data and their use for terrestrial radiocommunication services and another concerning data and their use for space radiocommunication services or the radio astronomy service. (WRC-12)

2 Both parts contain a list of characteristics and a table indicating the use of each of the characteristics in specific circumstances.

*Annex 1:* Characteristics of stations in the terrestrial services

*Annex 2:* Characteristics of satellite networks, earth stations or radio astronomy stations.

## ANNEX 1

**Characteristics of stations in the terrestrial services<sup>1</sup>**

In application of Appendix 4 there are many cases when the data requirements involve the use of standard symbols in submissions to the Radiocommunication Bureau. These standard symbols may be found in the Preface to the BR International Frequency Information Circular (BR IFIC) (Terrestrial Services). In the Tables, this is referred to simply as “the Preface”. Also additional information may be found in the guidelines published on the Bureau’s website.

**Key to the symbols used in Annex 1**

X	Mandatory information
+	Mandatory under the conditions specified in Column 3 of Table 1 and Column 2 of Table 2
O	Optional information
C	Mandatory if used as a basis to effect coordination with another administration
	The data item is not applicable to the corresponding notice

---

<sup>1</sup> The Radiocommunication Bureau shall develop and keep up-to-date forms of notice to meet fully the statutory provisions of this Appendix and related decisions of future conferences. Additional information on the items listed in this Annex together with an explanation of the symbols is to be found in the Preface to the BR IFIC (Terrestrial Services).



**Reading Appendix 4 Tables 1 and 2**

The rules used to link the sign with the text are based on the Table column headings covering specific procedures, services and frequency bands.

1 If any data item has the indication “+”, it shows that the data item is subject to a mandatory requirement under specific conditions. If these conditions are not met, the corresponding item is not applicable unless otherwise specified. These conditions are listed after the data item name and are normally presented as shown below.

2 “Required” without any reference to a column heading is used in the case that the associated condition is valid for every applicable column.

1.5.2	1B	the reference frequency, as defined in Article 1 Required if the modulation envelope is asymmetric	+	+	1B
-------	----	-------------------------------------------------------------------------------------------------------	---	---	----

“In the case of”, followed by a reference to the column heading is used, as shown below, when the associated conditions are different for individual columns, or if the indication is not the same across all applicable columns.

7.1	7A	the class of emission In the case of a VHF/UHF broadcasting station, required for assignments subject to § 5.1.3 of the GE06 Regional Agreement	+	X	7A
-----	----	----------------------------------------------------------------------------------------------------------------------------------------------------	---	---	----

3 A subheading title limits the range of procedures, services or frequency bands to which the data items grouped under that subheading are applicable. Unless further specific conditions apply, the data items grouped under that subheading have an “X” as the conditional nature is shown in the subheading title. (WRC-12)

1.4.3		<b>For assignments in the bands and services governed by the Geneva 06 Regional Agreement only</b>			
1.4.3.4	DAC	the digital broadcasting assignment code	X		DAC

**Footnotes to Tables 1 and 2**

<sup>1</sup> The most recent version of Recommendation ITU-R SF.675 should be used to the extent applicable in calculating the maximum power density per Hz.

TABLE 1 (Rev.WRC-15)  
**Characteristics for terrestrial services**

Column No.	Item identifier	Notice related to  Description of data items and requirements
<b>1</b>		<b>GENERAL INFORMATION AND FREQUENCY CHARACTERISTICS</b>
<b>1.1</b>	<b>B</b>	the symbol of the notifying administration (see the Preface)
<b>1.2</b>	<b>D</b>	the provision code of the Radio Regulations under which the notice has been submitted
<b>1.3</b>	<b>E</b>	the resubmission indicator In the case of a VHF/UHF broadcasting station, or a typical transmitting station, required for an assignment subject to the GE06 Regional Agreement if the notice is resubmitted in the application of Article 11 In the case of a transmitting station, or a receiving land station, required for an assignment subject to the GE06 Regional Agreement or Nos. 9.16, 9.18 or 9.19 if the notice is resubmitted in the application of Article 11
<b>1.4</b>		<b>Assignment and allotment identification information</b>
<b>1.4.1</b>	<b>SYNC</b>	the identification symbols for the synchronized, or single-frequency, network In the case of a VHF/UHF broadcasting station, required for a digital broadcasting assignment in a synchronized or single frequency network subject to the GE06 Regional Agreement In the case of an LF/MF broadcasting station, required for an assignment in a synchronized or single frequency network
<b>1.4.2</b>	<b>ID1</b>	the unique identification code given by the administration to the assignment or allotment Required for assignments subject to the GE06 Regional Agreement, and optional for assignments not subject to this Agreement
<b>1.4.3</b>		<b>For assignments in the bands and services governed by the GE06 Regional Agreement only:</b>
<b>1.4.3.1</b>	<b>ID2</b>	the unique identification code given by the administration for the associated allotment Required for a digital broadcasting assignment linked to an allotment, or converted from an allotment, within the GE06 Plan
<b>1.4.3.2</b>	<b>ID3</b>	the unique identification code given by the administration to the digital broadcasting Plan entry for which § 5.1.3 of the GE06 Agreement is to be applied Required if the notified assignment is to be operated under the mask of a digital broadcasting Plan entry in accordance with § 5.1.3 of the GE06 Regional Agreement
<b>1.4.3.3</b>	<b>DEC</b>	the digital broadcasting plan entry code that identifies the category of Plan entry to which the assignment belongs
<b>1.4.3.4</b>	<b>DAC</b>	the digital broadcasting assignment code

Broadcasting (sound and television) stations in the VHF/UHF bands up to 960 MHz, for the application of No. 11.2 and No. 9.21	Broadcasting (sound) stations in the LF/MF bands, for the application of No. 11.2	Transmitting stations (except broadcasting stations in the planned LF/MF bands, in the HF bands governed by Article 12, and in the VHF/UHF bands up to 960 MHz), for the application of No. 11.2 and No. 9.21	Receiving land stations, for the application of No. 11.9 and No. 9.21	Typical transmitting stations, for the application of No. 11.17	Maritime mobile frequency allotment, for the application of plan modification under Appendix 25 (Nos. 25/1.1.1, 25/1.1.2, 25/1.25)	Broadcasting stations in the HF bands, for the application of No. 12.16	Item identifier
X	X	X	X	X	X	X	B
X	X	X	X	X	X	X	D
+		+	+	+			E
+	+						SYNC
+	O	+	+	+	O		ID1
+							ID2
+		+	+				ID3
X							DEC
X							DAC

Column No.	Item identifier	<p style="text-align: center;">Notice related to</p> <p style="text-align: center;">Description of data items and requirements</p>
1.5		<b>Frequency information</b>
1.5.1	1A	the assigned frequency, as defined in Article 1 In the case of a transmitting station, required for all services, except adaptive systems in the fixed or mobile service operating in the bands between 300 kHz and 28 MHz (see also Resolution 729 (Rev.WRC-07)) In the case of an HF broadcasting station under Article 12, required if neither the preferred band nor reference frequency is provided
1.5.2	1B	the reference frequency, as defined in Article 1 Required if the modulation envelope is asymmetric
1.5.3	1G	the alternative frequency
1.5.4	1X	the channel number of the proposed or allotted channel Required for submissions in accordance with Nos. 25/1.1.1, 25/1.1.2 or 25/1.25 of Appendix 25 if the assistance of the Bureau is not requested under No. 25/1.3.1 of Appendix 25
1.5.5	1Y	the channel number of the alternative proposed channel
1.5.6	1Z	the channel number of the channel to be replaced Required if the administration needs to replace its existing allotted channel
1.5.7	1AA	the lower limit of the usable frequency range within which the carrier and the bandwidth of the emission will be located Required for adaptive systems in the fixed or mobile service operating in the bands between 300 kHz and 28 MHz (see also Resolution 729 (Rev.WRC-07))
1.5.8	1AB	the upper limit of the usable frequency range within which the carrier and the bandwidth of the emission will be located Required for adaptive systems in the fixed or mobile service operating in the bands between 300 kHz and 28 MHz (see also Resolution 729 (Rev.WRC-07))
1.5.9	1C	the preferred band, in MHz In the case of maritime mobile frequency allotment, required if the assistance of the Bureau is requested under No. 25/1.3.1 of Appendix 25 In the case of an HF broadcasting station under Article 12, required for notices if assistance is requested in accordance with No. 7.6
1.5.10		<b>For digital broadcasting (except assignments subject to § 5.1.3 of the GE06 Regional Agreement):</b>
1.5.10.1	1EO	the frequency offset, in kHz Required if the centre frequency of the emission is offset from the assigned frequency



Column No.	Item identifier	<p style="text-align: center;">Notice related to</p> <p style="text-align: center;">Description of data items and requirements</p>
1.5.11		<b>For analogue television broadcasting:</b>
1.5.11.1	1E	the vision carrier frequency offset, in multiples of 1/12 of the line frequency of the television system concerned, expressed by a number (positive or negative) Required if the vision carrier frequency offset, in kHz, (1E1) is not provided for assignments subject to the ST61, GE89 or GE06 Regional Agreements
1.5.11.2	1E1	the vision carrier frequency offset, in kHz, expressed by a number (positive or negative) Required if the vision carrier frequency offset, in multiples of 1/12 of the line frequency (1E) is not provided for assignments subject to the ST61, GE89 or GE06 Regional Agreements
1.5.11.3		<b>For the case where the sound carrier frequency offset is different from the vision carrier frequency offset:</b>
1.5.11.3.1	1EA	the sound carrier frequency offset, in multiples of 1/12 of the line frequency of the television system concerned, expressed by a number (positive or negative) Required if the sound carrier frequency offset, in kHz, (1EA) is not provided for assignments subject to the ST61, GE89 or GE06 Regional Agreements
1.5.11.3.2	1EA1	the sound carrier frequency offset, in kHz, expressed by a number (positive or negative) Required if the sound carrier frequency offset, in multiples of 1/12 of the line frequency (1EA) is not provided for assignments subject to the ST61, GE89 or GE06 Regional Agreements
2		<b>DATE OF OPERATION</b>
2.1	2C	the date (actual or foreseen, as appropriate) of bringing the frequency assignment (new or modified) into use
2.2	2E	the date for the end of operation of a frequency assignment In the case of a VHF/UHF broadcasting station, required, in the application of Article 11, when the operation of an assignment is limited to a specific period of time under § 4.1.5.4 of the GE06 Regional Agreement In the case of a transmitting station, a receiving land station, or a typical transmitting station, required, in the application of Article 11, when the operation of an assignment is limited to a specific period of time under § 4.2.5.5 of the GE06 Regional Agreement
2.3	2F	the season of operation code
2.4	10CA	the start date for the transmission
2.5	10CB	the stop date for the transmission
2.6	10CC	the days of operation for the transmission during the HFBC schedule
3		<b>CALL SIGN AND STATION IDENTIFICATION</b>
3.1	3A1	the call sign used in accordance with Article 19 In the case of a transmitting station, for the fixed service below 28 MHz, mobile service, meteorological aids service, radiolocation service between 3 and 50 MHz (operating in accordance with Resolution 612 (Rev.WRC-12)), or standard frequency and time signal service, in application of Article 11, required if the station identification (3A2) is not provided





Column No.	Item identifier	<p style="text-align: center;"><b>Notice related to</b></p> <hr/> <p style="text-align: center;"><b>Description of data items and requirements</b></p>
3.2	3A2	<p>the station identification used in accordance with Article 19</p> <p>In the case of a transmitting station, for the fixed service below 28 MHz, mobile service, meteorological aids service, radiolocation service between 3 and 50 MHz (operating in accordance with Resolution 612 (Rev.WRC-12)), or standard frequency and time signal service, in application of Article 11, required if the call sign (3A1) is not provided</p>
4		<b>LOCATION OF THE TRANSMITTING ANTENNA(S)</b>
4.1	4A	the name of the locality by which the transmitting station is known or in which it is situated
4.2	4AA	<p>the name of the location of the intended coast station</p> <p>Required for submissions in accordance with No. 25/1.1.1 of Appendix 25</p>
4.3	4B	the code of the geographical area in which the transmitting station is located (see the Preface)
4.4	4C	<p>the geographical coordinates of the transmitter site</p> <p>Latitude and longitude are provided in degrees, minutes and seconds</p>
4.5	4CA	<p>the geographical coordinates of the intended coast station</p> <p>Latitude and longitude are provided in degrees, minutes and seconds</p> <p>Required for submissions in accordance with No. 25/1.1.1 of Appendix 25</p>
4.6	4H	<p>HFBC site code</p> <p><i>Note</i> – The code is assigned by the Bureau prior to commencement of the Article 12 procedure and represents the location of the station, its geographical area and geographical coordinates</p>
4.7		<b>For an area in which transmitting stations operate:</b>
4.7.1	4CC	<p>the geographical coordinates of the centre of the circular zone, in which mobile transmitting stations associated with a receiving land station, or a typical transmitting station are operating</p> <p>Latitude and longitude are provided in degrees, minutes and seconds</p> <p>In the case of a receiving land station, required:</p> <ul style="list-style-type: none"> <li>– for the maritime radionavigation service; and</li> <li>– for other services if the code of a geographical area or standard defined area (4E) is not provided</li> </ul> <p>In the case of a typical transmitting station, required if a geographical area or standard defined area (4E) is not provided</p>
4.7.2	4D	<p>the nominal radius, in km, of the circular zone, in which mobile transmitting stations associated with a receiving land station, or a typical transmitting station are operating</p> <p>In the case of a receiving land station, required:</p> <ul style="list-style-type: none"> <li>– for the maritime radionavigation service; and</li> <li>– for other services if the code of a geographical area or standard defined area (4E) is not provided</li> </ul> <p>In the case of a typical transmitting station, required if a geographical area or standard defined area (4E) is not provided</p>

Broadcasting (sound and television) stations in the VHF/UHF bands up to 960 MHz, for the application of No. 11.2 and No. 9.21							
Broadcasting (sound) stations in the LF/MF bands, for the application of No. 11.2	O						
Transmitting stations (except broadcasting stations in the planned LF/MF bands, in the HF bands governed by Article 12, and in the VHF/UHF bands up to 960 MHz), for the application of No. 11.2 and No. 9.21	O	+					
Receiving land stations, for the application of No. 11.9 and No. 9.21							
Typical transmitting stations, for the application of No. 11.17							
Maritime mobile frequency allotment, for the application of plan modification under Appendix 25 (Nos. 25/1.1.1, 25/1.1.2, 25/1.25)					+		
Broadcasting stations in the HF bands, for the application of No. 12.16	O					X	
							3A2
	X	X	X				4A
							4AA
	X	X	X				4B
	X	X	X				4C
							4CA
							4H
							4CC
			+		+		
			+		+		4D

Column No.	Item identifier	<p style="text-align: right;">Notice related to</p> <p style="text-align: center;">Description of data items and requirements</p>
4.7.3	4E	<p>the code of the geographical area or standard defined area (see the Preface)</p> <p><i>Note</i> – The standard defined area for a receiving land station in the maritime mobile service may be a maritime zone. The standard defined area for a maritime mobile frequency allotment is the allotment area</p> <p>In the case of a receiving land station, for all services, except the maritime radionavigation service, required if a circular zone (4CC and 4D) is not provided</p> <p>In the case of a typical transmitting station, required if a circular zone (4CC and 4D) is not provided</p>
4.8	4G	<p>the ground conductivity</p> <p>Required for an assignment subject to the GE75 Regional Agreement</p>
5		<b>LOCATION OF THE RECEIVING ANTENNA(S)</b>
5.1	5A	<p>the name of the locality by which the receiving station is known or in which it is situated</p> <p>In the case of a transmitting station, required for an associated receiving station in the fixed service if the geographical coordinates of a given reception zone (5CA) are not provided</p>
5.2	5B	<p>the code of the geographical area in which the receiving station(s) is located (see the Preface)</p> <p>In the case of a transmitting station, required for an associated receiving station in the fixed service if the geographical coordinates of a given reception zone (5CA) are not provided</p>
5.3	5C	<p>the geographical coordinates of the site of the receiving station</p> <p>Latitude and longitude are provided in degrees, minutes and seconds</p> <p>In the case of a transmitting station, required for an associated receiving station in the fixed service if the geographical coordinates of a given reception zone (5CA) are not provided</p>
5.4		<b>For an area in which receiving stations operate:</b>
5.4.1	5CA	<p>the geographical coordinates of a given reception zone</p> <p>A minimum of 3 geographical coordinates are to be provided. All geographical coordinates (latitude and longitude) are provided in degrees, minutes and seconds</p> <p>For an associated receiving station in the fixed service, required if the name of the locality (5A), geographical area (5B) and geographical coordinates (5C) are not provided</p> <p>For all other services, except where the assignment is subject to the GE06 Agreement, required if neither a circular area (5E and 5F) nor a geographical area or standard defined area of reception (5D) is provided</p>

Broadcasting (sound and television) stations in the VHF/UHF bands up to 960 MHz, for the application of No. 11.2 and No. 9.21							
Broadcasting (sound) stations in the LF/MF bands, for the application of No. 11.2	+						4E
Transmitting stations (except broadcasting stations in the planned LF/MF bands, in the HF bands governed by Article 12, and in the VHF/UHF bands up to 960 MHz), for the application of No. 11.2 and No. 9.21							4G
Receiving land stations, for the application of No. 11.9 and No. 9.21			+				
Typical transmitting stations, for the application of No. 11.17				+			
Maritime mobile frequency allotment, for the application of plan modification under Appendix 25 (Nos. 25/1.1.1, 25/1.1.2, 25/1.25)					X		
Broadcasting stations in the HF bands, for the application of No. 12.16							
							5A
			+	X			
			+	X			5B
			+	X			5C
			+				5CA

Column No.	Item identifier	<p style="text-align: center;">Notice related to</p> <hr/> <p style="text-align: center;">Description of data items and requirements</p>
5.4.2	5D	<p>the code of the geographical area or standard defined area of reception (see the Preface)</p> <p><i>Note</i> – The standard defined area of a transmitting station may be represented by a maritime zone or aeronautical zone. The standard defined area of a maritime mobile frequency allotment is a maritime zone. The standard defined area of an HF broadcasting station subject to Article 12 is represented by a CIRAF zone</p> <p>In the case of a transmitting station, except transmitting stations in the fixed service, maritime radionavigation service, aeronautical radionavigation service subject to the GE85-MM-R1 Regional Agreement or the maritime mobile service subject to the GE85-MM-R1 Regional Agreement, required if neither a circular receiving area (5E and 5F) nor geographical coordinates of a given reception zone (5CA) is provided</p>
5.4.3	5E	<p>the geographical coordinates of the centre of the circular receiving area</p> <p>Latitude and longitude are provided in degrees, minutes and seconds</p> <p>Required:</p> <ul style="list-style-type: none"> <li>– for the maritime radionavigation service, aeronautical radionavigation service subject to the GE85-MM-R1 Regional Agreement or the maritime mobile service subject to the GE85-MM-R1 Regional Agreement; and</li> <li>– for all other services, except the fixed service, if neither a geographical area or standard defined area of reception (5D) nor the geographical coordinates of a given reception zone (5CA) is provided</li> </ul>
5.4.4	5F	<p>the radius, in km, of the circular receiving area</p> <p>Required:</p> <ul style="list-style-type: none"> <li>– for the maritime radionavigation service, aeronautical radionavigation service subject to the GE85-MM-R1 Regional Agreement or the maritime mobile service subject to the GE85-MM-R1 Regional Agreement; and</li> <li>– for all other services, except the fixed service, if neither the geographical area or standard defined area of reception (5D) nor the geographical coordinates of a given reception zone (5CA) is provided</li> </ul>
5.5	5G	<p>the maximum length of the circuit, in km, for non-circular receiving areas</p> <p>Stations in the HF bands only</p>
6		<b>CLASS OF STATION AND NATURE OF SERVICE</b>
6.1	6A	<p>the class of station, using the symbols from the Preface</p>
6.2	6B	<p>the nature of service, using the symbols from the Preface</p> <p>In the case of a transmitting station, required for all services, except the broadcasting service</p>
7		<p><b>CLASS OF EMISSION AND NECESSARY BANDWIDTH</b></p> <p><i>(in accordance with Article 2 and Appendix 1)</i></p>
7.1	7A	<p>the class of emission</p> <p>In the case of a VHF/UHF broadcasting station, required for digital broadcasting assignments</p>
7.2	7AB	<p>the necessary bandwidth</p> <p>In the case of a VHF/UHF broadcasting station, required for analogue sound and digital broadcasting assignments</p>

Broadcasting (sound and television) stations in the VHE/UHF bands up to 960 MHz, for the application of No. 11.2 and No. 9.21							
Broadcasting (sound) stations in the LF/MF bands, for the application of No. 11.2							
Transmitting stations (except broadcasting stations in the planned LF/MF bands, in the HF bands governed by Article 12, and in the VHE/UHF bands up to 960 MHz), for the application of No. 11.2 and No. 9.21		+			X	X	5D
Receiving land stations, for the application of No. 11.9 and No. 9.21							
Typical transmitting stations, for the application of No. 11.17							
Maritime mobile frequency allotment, for the application of plan modification under Appendix 25 (Nos. 25/1.1.1, 25/1.1.2, 25/1.25)							
Broadcasting stations in the HF bands, for the application of No. 12.16							
							5E
		+					5F
		O			O		5G
X	X	X	X	X	X	X	6A
		+	X	X	X		6B
+	X	X	X	X	X		7A
+	X	X	X	X	X	X	7AB

Column No.	Item identifier	<p style="text-align: center;">Notice related to</p> <hr/> <p style="text-align: center;">Description of data items and requirements</p>
7.3		<b>System characteristics:</b>
7.3.1	7A1	the code describing the frequency stability (RELAXED, NORMAL or PRECISION) Required for analogue television broadcasting
7.3.2	7AA	the code for the type of modulation The type of modulation denotes the use of DSB, SSB or any new modulation techniques recommended by ITU-R
7.3.3	7B1	the adjacent channel protection ratio, in dB Required for the GE75 Regional Agreement
7.3.4	7B2	the “RJ 81 class” (A, B or C) Required for the RJ81 Regional Agreement
7.3.5	7G	the system code <i>Note</i> – The code identifies the category of system to which the station belongs and hence its protection requirements In the VHF band two codes are required for protection from T-DAB and DVB-T In the UHF band only one code is required for protection from DVB-T Required for an assignment subject to the GE06 Regional Agreement
7.3.6	7C1	the code identifying the television system (see the Preface) Required for television broadcasting assignments, except assignments subject to § 5.1.3 of the GE06 Regional Agreement
7.3.7	7C2	the code corresponding to the colour system (see the Preface) Required for analogue television broadcasting
7.3.8	7D	the code corresponding to the sound broadcasting transmission system (see the Preface) <i>Note</i> – For LF/MF systems, the signal may consist of analogue or digital modulation or a combination of them: the latter case is referred to as hybrid modulation In the case of a VHF/UHF broadcasting station, required for sound broadcasting assignments, except assignments subject to the GE06 Regional Agreement In the case of an LF/MF broadcasting station, required for an assignment with digital or hybrid modulation
7.3.9		<b>For the GE06 Regional Agreement (except notices subject to § 5.1.3 of the GE06 Regional Agreement):</b>
7.3.9.1	7H	the reference planning configuration (see the Preface) Required for digital sound broadcasting
7.3.9.2	7J	the type of spectrum mask
7.3.9.3	7K	the reception mode (see the Preface) Required for digital television broadcasting
7.3.10		<b>For the fixed service in the bands shared with space services and any type of modulation as applicable:</b>
7.3.10.1	7E	the peak to peak frequency deviation, in MHz
7.3.10.2	7F	the sweep frequency, in kHz, of the energy dispersal waveform

Broadcasting (sound and television) stations in the VHF/UHF bands up to 960 MHz, for the application of No. 11.2 and No. 9.21	Broadcasting (sound) stations in the LF/MF bands, for the application of No. 11.2	Transmitting stations (except broadcasting stations in the planned LF/MF bands, in the HF bands governed by Article 12, and in the VHF/UHF bands up to 960 MHz), for the application of No. 11.2 and No. 9.21	Receiving land stations, for the application of No. 11.9 and No. 9.21	Typical transmitting stations, for the application of No. 11.17	Maritime mobile frequency allotment, for the application of plan modification under Appendix 25 (Nos. 25/1.1.1, 25/1.1.2, 25/1.25)	Broadcasting stations in the HF bands, for the application of No. 12.16	Item identifier
+							7A1
						X	7AA
	+						7B1
	+						7B2
		+	+	+			7G
+							7C1
+							7C2
+	+						7D
+							7H
X							7J
+							7K
		C					7E
		C					7F



Column No.	Item identifier	<p style="text-align: center;">Notice related to</p> <p style="text-align: center;">Description of data items and requirements</p>
<b>8</b>		<b>POWER CHARACTERISTICS</b>
8.1	<b>8</b>	the symbol (X, Y or Z, as appropriate) describing the type of power (see Article 1) corresponding to the class of emission
8.2	<b>8A</b>	the power delivered to the antenna transmission line, in kW
8.3	<b>8AA</b>	<p>the power delivered to the antenna, in dBW</p> <p>In the case of a transmitting station, required for an assignment:</p> <ul style="list-style-type: none"> <li>– in the bands below 28 MHz, in all services except the radionavigation service; or – in the bands above 28 MHz shared with space services; or</li> <li>– in the bands above 28 MHz not shared with space services: <ul style="list-style-type: none"> <li>• in the aeronautical mobile service, meteorological aids service; or</li> <li>• in all other services, if the radiated power is not supplied</li> </ul> </li> </ul> <p>In the case of a receiving land station, required if the associated transmitting station's radiated power is not supplied</p> <p>In the case of a typical transmitting station, required if the radiated power is not supplied</p>
8.4	<b>8AB</b>	<p>the maximum power density<sup>1</sup> (dB(W/Hz)) for each carrier type averaged over the worst 4 kHz band for carriers below 15 GHz, or averaged over the worst 1 MHz band for carriers above 15 GHz, supplied to the antenna transmission line</p> <p>For the fixed service in the bands shared with space services</p>
8.5	<b>8AC</b>	<p>the maximum power density (dB(W/Hz)) averaged over the worst 4 kHz band, calculated for the maximum effective radiated power</p> <p><i>Note</i> – For a receiving land station, the maximum power density refers to the associated transmitting station</p> <p>In the case of a VHF/UHF broadcasting station, required for assignments subject to § 5.1.3 of the GE06 Regional Agreement</p> <p>In the case of a transmitting station, a receiving land station, or a typical transmitting station, required for assignments subject to the GE06 Regional Agreement</p>
8.6	<b>8B</b>	<p>the radiated power, in dBW, in one of the forms described in Nos. <b>1.161</b> to <b>1.163</b></p> <p><i>Note</i> – Where adaptive systems in the fixed or mobile service operating in the bands between 300 kHz and 28 MHz (see also Resolution <b>729 (Rev.WRC-07)</b>) use automatic power control, the radiated power includes the level of power control listed under 8BA</p> <p>For assignments in all services and frequency bands, except assignments subject to the GE06 Regional Agreement, required if the power delivered to the antenna (8AA), or the maximum antenna gain (9G), is not provided</p> <p>For an assignment subject to the GE06 Regional Agreement, required if the power delivered to the antenna (8AA) is not provided</p>
8.7	<b>8BA</b>	<p>the range of power control, in dB</p> <p>Required for adaptive systems in the fixed or mobile service operating in the bands between 300 kHz and 28 MHz (see also Resolution <b>729 (Rev.WRC-07)</b>), if automatic power control is used</p>
8.8	<b>8BH</b>	<p>the maximum effective radiated power, in dBW, of the horizontally polarized component</p> <p>Required for horizontal or mixed polarization</p>

Broadcasting (sound and television) stations in the VHF/UHF bands up to 960 MHz, for the application of No. 11.2 and No. 9.21	Broadcasting (sound) stations in the LF/MF bands, for the application of No. 11.2	Transmitting stations (except broadcasting stations in the planned LF/MF bands, in the HF bands governed by Article 12, and in the VHF/UHF bands up to 960 MHz), for the application of No. 11.2 and No. 9.21	Receiving land stations, for the application of No. 11.9 and No. 9.21	Typical transmitting stations, for the application of No. 11.17	Maritime mobile frequency allotment, for the application of plan modification under Appendix 25 (Nos. 25/1.1.1, 25/1.1.2, 25/1.25)	Broadcasting stations in the HF bands, for the application of No. 12.16	Item identifier
X	X	X	X	X	X	X	8
	X					X	8A
		+	+	+	X		8AA
		C					8AB
+		+	+	+			8AC
		+	+	+			8B
		+					8BA
+							8BH

Column No.	Item identifier	<p style="text-align: right;">Notice related to</p> <p style="text-align: center;">Description of data items and requirements</p>
8.9	8BV	the maximum effective radiated power, in dBW, of the vertically polarized component Required for vertical or mixed polarization
8.10	8BT	the maximum effective radiated power, in dBW, in the plane defined by the beam tilt angle For a digital broadcasting assignment in the UHF band subject to the GE06 Regional Agreement only
8.11	8D	the vision-to-sound carrier power ratio, in dB Required for analogue television broadcasting
8.12	9L	the maximum effective monopole radiated power, in dB(kW) Required for the GE75 Regional Agreement
8.13		<b>For the RJ81 and RJ88 Regional Agreements:</b>
8.13.1	9I	the r.m.s. value of radiation The product of the r.m.s. characteristic field strength in the horizontal plane and the square root of the power
8.13.2	9IA	the value of the radiation at the central azimuth of the augmentation, in mV/m at 1 km Required for antenna radiation pattern type "M" (see 9O)
8.13.3	9P	the value of the special quadrature factor, in mV/m at 1 km <i>Note</i> – A special quadrature factor may be used with antenna pattern type "M" or "E" to replace the normal expanded quadrature factor when special precautions are taken to ensure pattern stability
9		<b>ANTENNA CHARACTERISTICS</b>
9.1		<b>For a transmitting or receiving antenna:</b>
9.1.1	9	the indicator showing whether the antenna is directional (D) or non-directional (ND) In the case of a receiving land station, required for an assignment subject to the GE06 Regional Agreement
9.1.2	9D	the code indicating the type of polarization (see the Preface) In the case of a transmitting station, required for an assignment: – in the fixed service in the bands shared with space services; or – subject to the GE06 Regional Agreement In the case of a receiving land station, required for an assignment subject to the GE06 Regional Agreement
9.1.3	9E	the height of the antenna above ground level, in metres In the case of a VHF/UHF broadcasting station, required for the ST61, GE84, GE89 or GE06 Regional Agreements, and optional for assignments not subject to these Agreements In the case of a transmitting station, required for an assignment: – in the bands shared with space services; or – subject to the GE06 Regional Agreement In the case of a receiving land station, required for an assignment subject to the GE06 Regional Agreement

Broadcasting (sound and television) stations in the VHF/UHF bands up to 960 MHz, for the application of No. 11.2 and No. 9.21	Broadcasting (sound) stations in the LF/MF bands, for the application of No. 11.2	Transmitting stations (except broadcasting stations in the planned LF/MF bands, in the HF bands governed by Article 12, and in the VHF/UHF bands up to 960 MHz), for the application of No. 11.2 and No. 9.21	Receiving land stations, for the application of No. 11.9 and No. 9.21	Typical transmitting stations, for the application of No. 11.17	Maritime mobile frequency allotment, for the application of plan modification under Appendix 25 (Nos. 25/1.1.1, 25/1.1.2, 25/1.25)	Broadcasting stations in the HF bands, for the application of No. 12.16	Item identifier
+							8BV
O							8BT
+							8D
	+						9L
	X						9I
	+						9IA
	O						9P
X		X	+		X	X	9
X		+	+				9D
+		+	+				9E

Column No.	Item identifier	<p style="text-align: center;">Description of data items and requirements</p> <p style="text-align: right;">Notice related to</p>
9.2		<b>For a directional transmitting or receiving antenna:</b>
9.2.1	9C	<p>the total angular width of the radiation main lobe (beamwidth) measured horizontally in a plane containing the direction of maximum radiation, in degrees, within which the power radiated in any direction does not fall more than 3 dB below the power radiated in the direction of maximum radiation</p> <p>In the case of a transmitting station, required for all assignments, except assignments subject to GE06 Regional Agreement where it is optional</p> <p>In the case of a receiving land station, for an assignment subject to the GE06 Regional Agreement only</p>
9.2.2	9GL	<p>the antenna gain towards the local horizon</p> <p>For an assignment subject to the GE06 Regional Agreement only</p>
9.2.3	9K	<p>the lowest total receiving system noise temperature, in kelvins</p> <p>For an associated receiving antenna in the fixed service operating in the bands shared with space services only</p>
9.3		<b>For a transmitting antenna:</b>
9.3.1	9EA	<p>the altitude of the site above mean sea level, in metres</p> <p>In the case of a VHF/UHF broadcasting station, required for assignments subject to the ST61, GE84, GE89, or GE06 Regional Agreements, and optional for assignments not subject to these Agreements</p> <p>In the case of a transmitting station, required for an assignment:</p> <ul style="list-style-type: none"> <li>- in the fixed or mobile service in the bands shared with space services; or</li> <li>- subject to the GE06 Regional Agreement</li> </ul>
9.3.2	9EB	<p>the maximum effective height of the antenna, in metres, above the mean level of the ground between 3 and 15 km from the transmitting antenna</p> <p>In the case of a transmitting station, required for an assignment subject to the GE06 Regional Agreement</p>
9.3.3	9EC	<p>the effective height of the antenna, in metres, above the mean level of the ground between 3 and 15 km from the transmitting antenna, at 36 different azimuths in 10° intervals (i.e. 0°, 10°, ..., 350°), measured in the horizontal plane from True North in a clockwise direction</p> <p>In the case of a VHF/UHF broadcasting station, required for an assignment subject to the ST61, GE84, GE89 or GE06 Regional Agreements</p> <p>In the case of a transmitting station, required for an assignment subject to the GE06 Regional Agreement</p>

Broadcasting (sound and television) stations in the VHF/UHF bands up to 960 MHz, for the application of No. 11.2 and No. 9.21	Broadcasting (sound) stations in the LF/MF bands, for the application of No. 11.2	Transmitting stations (except broadcasting stations in the planned LF/MF bands, in the HF bands governed by Article 12, and in the VHF/UHF bands up to 960 MHz), for the application of No. 11.2 and No. 9.21	Receiving land stations, for the application of No. 11.9 and No. 9.21	Typical transmitting stations, for the application of No. 11.17	Maritime mobile frequency allotment, for the application of plan modification under Appendix 25 (Nos. 25/1.1.1, 25/1.1.2, 25/1.25)	Broadcasting stations in the HF bands, for the application of No. 12.16	Item identifier
		+	O		X		9C
		O	O				9GL
		C					9K
+		+					9EA
X		+					9EB
+		+					9EC

Column No.	Item identifier	<p style="text-align: center;">Notice related to</p> <p style="text-align: center;">Description of data items and requirements</p>
9.3.4	9G	<p>the maximum antenna gain (isotropic, relative to a short vertical antenna or relative to a half-wave dipole, as appropriate) of the transmitting antenna (see No. 1.160)</p> <p>For a directional antenna, the gain is in the direction of maximum radiation</p> <p>In the case of a transmitting station, or a typical transmitting station:</p> <ul style="list-style-type: none"> <li>– for all frequency bands and services, except assignments subject to the GE06 Regional Agreement, required if the antenna is: <ul style="list-style-type: none"> <li>– directional, including where the antenna beam is rotating or swept; or</li> <li>– non-directional, and the power to the antenna (8AA) or the radiated power (8B) is not provided</li> </ul> </li> <li>– for an assignment subject to the GE06 Regional Agreement required if the radiated power (8B) is not provided</li> </ul> <p>In the case of a maritime mobile frequency allotment, required if the antenna is directional, including where the antenna beam is rotating or swept</p>
9.3.5	9M	the transmitting antenna design frequency
9.3.6	9S	<p>the beam tilt angle, in degrees</p> <p>The beam tilt angle is measured from the horizontal plane towards ground and the sign of the angle is negative</p> <p><i>Note</i> – In some broadcasting definitions, the angle may have the opposite sign</p> <p>For a digital broadcasting assignment in the UHF band subject to the GE06 Regional Agreement only</p>
9.3.7	9J	the measured radiation pattern of the antenna, the reference radiation pattern or the symbols in standard references to be used for coordination
9.4		<b>For a directional transmitting antenna where the antenna beam is rotating or swept:</b>
9.4.1	9AB1	the start azimuth for the range of operational angles for the antenna’s main beam axis, measured in the horizontal plane from True North in a clockwise direction
9.4.2	9AB2	the end azimuth for the range of operational angles for the antenna’s main beam axis, measured in the horizontal plane from True North in a clockwise direction
9.5		<b>For a directional transmitting antenna where the antenna beam is not rotating or swept:</b>
9.5.1	9A	the azimuth of maximum radiation of the transmitting antenna, measured in the horizontal plane from True North in a clockwise direction
9.5.2	9B	<p>the elevation angle of maximum directivity, in degrees</p> <p>Required for an assignment in the bands shared with space services</p>
9.5.3	9R	the slew angle measured between the azimuth of maximum radiation and the direction of unslewed radiation
9.5.4	9NH	<p>the value of attenuation of the horizontally polarized component, at 36 different azimuths in 10° intervals (i.e. 0°, 10°, ..., 350°), measured in the horizontal plane from True North in a clockwise direction, with respect to the maximum effective radiated power of this component, in dB</p> <p>For all assignments, except digital broadcasting assignments subject to the GE06 Regional Agreement and broadcasting assignments subject to § 5.1.3 of the GE06 Regional Agreement, required if the polarization is horizontal or mixed</p>

Broadcasting (sound and television) stations in the VHE/UHF bands up to 960 MHz, for the application of No. 11.2 and No. 9.21								
Broadcasting (sound) stations in the LF/MF bands, for the application of No. 11.2								
Transmitting stations (except broadcasting stations in the planned LF/MF bands, in the HF bands governed by Article 12, and in the VHE/UHF bands up to 960 MHz), for the application of No. 11.2 and No. 9.21	+							
Receiving land stations, for the application of No. 11.9 and No. 9.21								
Typical transmitting stations, for the application of No. 11.17	+							
Maritime mobile frequency allotment, for the application of plan modification under Appendix 25 (Nos. 25/1.1.1, 25/1.1.2, 25/1.25)	+							
Broadcasting stations in the HF bands, for the application of No. 12.16						X		9G
						X		9M
O						X		9S
						X		9J
							X	9AB1
							X	9AB2
						X	X	9A
								9B
								9R
						X		9NH
+								



Column No.	Item identifier	<p style="text-align: center;">Notice related to</p> <p style="text-align: center;">Description of data items and requirements</p>
9.5.5	9NV	<p>the value of attenuation of the vertically polarized component, at 36 different azimuths in 10° intervals (i.e. 0°, 10°, ..., 350°), measured in the horizontal plane from True North in a clockwise direction, with respect to the maximum effective radiated power of this component, in dB</p> <p>For all assignments, except digital broadcasting assignments subject to the GE06 Regional Agreement and broadcasting assignments subject to § 5.1.3 of the GE06 Regional Agreement, required if the polarization is vertical or mixed</p>
9.5.6	9UH	<p>the value of attenuation of the horizontally polarized component in the horizontal plane, normalized to 0 dB, at 36 different azimuths in 10° intervals (i.e. 0°, 10°, ..., 350°), measured in the horizontal plane from True North in a clockwise direction, with respect to the maximum radiated power of this component, in dB</p> <p>In the case of a VHF/UHF broadcasting station, for a digital broadcasting assignment subject to the GE06 Regional Agreement and an assignment subject to § 5.1.3 of the GE06 Regional Agreement, required if the polarization is horizontal or mixed</p> <p>In the case of a transmitting station, for an assignment subject to § 5.1.3 of the GE06 Regional Agreement, required if the polarization is horizontal or mixed</p>
9.5.7	9UV	<p>the value of attenuation of the vertically polarized component in the horizontal plane, normalized to 0 dB, at 36 different azimuths in 10° intervals (i.e. 0°, 10°, ..., 350°), measured in the horizontal plane from True North in a clockwise direction, with respect to the maximum radiated power of this component, in dB</p> <p>In the case of a VHF/UHF broadcasting station, for a digital broadcasting assignment subject to the GE06 Regional Agreement and an assignment subject to § 5.1.3 of the GE06 Regional Agreement, required if the polarization is vertical or mixed</p> <p>In the case of a transmitting station, for an assignment subject to § 5.1.3 of the GE06 Regional Agreement, required if the polarization is vertical or mixed</p>
9.6	9Q	<p>the symbol identifying the type of antenna</p> <p>Type A – a simple vertical antenna</p> <p>Type B – a directional or omnidirectional antenna of complex construction</p>
9.7		<p><b>For a type A antenna (simple vertical antenna):</b></p>
9.7.1	9EP	<p>the transmitting antenna's physical length in metres</p> <p>Required for the GE75 Regional Agreement</p>
9.7.2	9F	<p>the electrical height of the antenna, in degrees</p> <p>Required for the RJ81 or RJ88 Regional Agreements</p>
9.8		<p><b>For a station subject to the GE75 Regional Agreement with a type B antenna (a directional antenna, or omnidirectional antenna of complex construction):</b></p>
9.8.1	9GH	<p>the antenna gain, in dB, in the horizontal plane, at 36 different azimuths in 10° intervals (i.e. 0°, 10°, ..., 350°), measured in the horizontal plane from True North in a clockwise direction</p>



Column No.	Item identifier	<p style="text-align: center;">Notice related to</p> <p style="text-align: center;">Description of data items and requirements</p>
9.8.2	9GV	<p>the antenna gain, in dB, in the vertical plane, at 36 different azimuths in 10° intervals (i.e. 0°, 10°, ..., 350°) measured in the horizontal plane from True North in a clockwise direction, and at ten different elevations in 10° intervals (i.e. 0°, 10°, ..., 90°) measured in the vertical plane</p> <p><i>Note</i> – If administrations have difficulty in providing this information, they can provide a reference to any other information that may be of assistance (e.g. ITU-R Recommendation, antenna pattern)</p> <p>Required for an assignment to be used for night-time operation</p>
9.9		<p><b>For a station subject to the RJ81 or RJ88 Regional Agreements with a type B antenna (a directional antenna, or omnidirectional antenna of complex construction):</b></p>
9.9.1	9O	<p>the symbol identifying the type of antenna radiation pattern (T, M, or E)</p>
9.9.2		<p><b>For antenna radiation pattern type M:</b></p>
9.9.2.1	9NA	<p>the serial number of the augmentation as described by items 9IA, 9AA and 9CA</p>
9.9.2.2	9AA	<p>the central azimuth of the augmentation (centre of the span) in degrees</p>
9.9.2.3	9CA	<p>the total span of the augmentation, in degrees</p>
9.9.3		<p><b>For each tower of a type B antenna in the RJ81 or RJ88 Regional Agreements:</b></p>
9.9.3.1	9T1	<p>the serial number of each of the towers whose characteristics are described in items 9T2 to 9T8</p>
9.9.3.2	9T8	<p>the symbol corresponding to the tower structure</p>
9.9.3.3	9T7	<p>the electrical height, in degrees, of the tower under consideration</p> <p>Required if the tower is not top-loaded nor sectionalized (see 9.9.4)</p>
9.9.3.4	9T2	<p>the ratio of the tower field to the field of the reference tower</p> <p>Required if the antenna consists of two or more towers</p>
9.9.3.5	9T3	<p>the positive or negative phase difference in the tower field with respect to the field of the reference tower, in degrees</p> <p>Required if the antenna consists of two or more towers</p>
9.9.3.6	9T4	<p>the electrical spacing of the tower from the reference point, in degrees</p> <p>Required if the antenna consists of two or more towers</p>
9.9.3.7	9T5	<p>the angular orientation of the tower from the reference point, in degrees (clockwise) from True North</p> <p>Required if the antenna consists of two or more towers</p>
9.9.4		<p><b>For each tower of a type B antenna that is top-loaded or sectionalized in accordance with the Regional Administrative MF Broadcasting Conference (Region 2) Rio de Janeiro, 1981 or 1988 Agreements:</b></p>
9.9.4.1	9T9A	<p>the description of a top-loaded or sectionalized tower</p>
9.9.4.2	9T9B	<p>the description of a top-loaded or sectionalized tower</p> <p>Required if tower structure symbol (9T8) is 1, 2, 5, 6, 7, 8 or 9</p>
9.9.4.3	9T9C	<p>the description of a top-loaded or sectionalized tower</p> <p>Required if the tower structure symbol (9T8) is 2, 5, 7 or 8</p>

Broadcasting (sound and television) stations in the VHF/UHF bands up to 960 MHz, for the application of No. 11.2 and No. 9.21	Broadcasting (sound) stations in the LF/MF bands, for the application of No. 11.2	Transmitting stations (except broadcasting stations in the planned LF/MF bands, in the HF bands governed by Article 12, and in the VHF/UHF bands up to 960 MHz), for the application of No. 11.2 and No. 9.21	Receiving land stations, for the application of No. 11.9 and No. 9.21	Typical transmitting stations, for the application of No. 11.17	Maritime mobile frequency allotment, for the application of plan modification under Appendix 25 (Nos. 25/1.1.1, 25/1.1.2, 25/1.25)	Broadcasting stations in the HF bands, for the application of No. 12.16	Item identifier
	+						9GV
	X						9O
	X						9NA
	X						9AA
	X						9CA
	X						9T1
	X						9T8
	+						9T7
	+						9T2
	+						9T3
	+						9T4
	+						9T5
	X						9T9A
	+						9T9B
	+						9T9C

Column No.	Item identifier	<p style="text-align: center;">Notice related to</p> <p style="text-align: center;">Description of data items and requirements</p>
9.9.4.4	9T9D	<p>the description of a top-loaded or sectionalized tower</p> <p>Required if tower structures symbol (9T8) is 2, 5 or 8</p>
10		<b>HOURS OF OPERATION</b>
10.1	10B	the regular hours of operation (in hours and minutes from ... to ...) of the frequency assignment, in UTC
10.2	10BA	the local operation period code (see the Preface)
10.3	10D	the estimated peak hours of traffic
10.4	10E	the estimated daily volume of traffic
11		<b>COORDINATION AND AGREEMENT</b>
11.1	11	<p>the symbol of each administration with which coordination has been successfully effected</p> <p>Required if coordination is necessary and has been obtained pursuant to the relevant provisions of the Radio Regulations</p>
11.2	11D	<p>a declaration by the notifying administration that all conditions associated with the remark are fully met for recording the submitted assignment in the Master International Frequency Register</p> <p>Required for a digital broadcasting assignment subject to § 5.1.2 of the GE06 Regional Agreement and for the broadcasting and other primary services assignments notified pursuant to No. 5.1.3 of the Agreement</p>
11.3	11C	<p>a signed commitment from the notifying administration that the submitted assignment for recording in the Master International Frequency Register shall not cause unacceptable interference and shall not claim protection</p> <p>Required for an assignment subject to § 5.1.8 of the GE06 Regional Agreement</p>
11.4	11E	<p>a signed commitment from the notifying administration that the submitted assignment for recording in the Master International Frequency Register shall not cause unacceptable interference and shall not claim protection</p> <p>Required for an assignment subject to § 5.2.6 of the GE06 Regional Agreement</p>
11.5	11F	<p>Recognition by the notifying administration that the registration of assignments in the aeronautical mobile (R) service in the 5 030-5 091 MHz frequency band accords with the purposes of ITU, including No. 7 of Article 1 of the ITU Constitution.</p> <p>Required for an assignment in aeronautical mobile (R) service in the frequency band 5 030-5 091 MHz</p>
12		<b>OPERATING ADMINISTRATION OR AGENCY</b>
12.1	12A	the symbol for the operating agency
12.2	12B	<p>the symbol for the address of the administration responsible for the station and to which communication should be sent on urgent matters regarding interference, quality of emissions and questions referring to the technical operation of the circuit (see Article 15, also the Preface)</p> <p>In the case of a VHF/UHF broadcasting station, transmitting station, or a receiving land station, required for application of Article 11</p>
13		<b>REMARKS</b>
13.1	13C	Remarks for assisting the Bureau in processing the notice

Broadcasting (sound and television) stations in the VHF/UHF bands up to 960 MHz, for the application of No. 11.2 and No. 9.21	Broadcasting (sound) stations in the LF/MF bands, for the application of No. 11.2	Transmitting stations (except broadcasting stations in the planned LF/MF bands, in the HF bands governed by Article 12, and in the VHF/UHF bands up to 960 MHz), for the application of No. 11.2 and No. 9.21	Receiving land stations, for the application of No. 11.9 and No. 9.21	Typical transmitting stations, for the application of No. 11.17	Maritime mobile frequency allotment, for the application of plan modification under Appendix 25 (Nos. 25/1.1.1, 25/1.1.2, 25/1.25)	Broadcasting stations in the HF bands, for the application of No. 12.16	Item identifier
	+						9T9D
X	O	X	X	X	X	X	10B
	X						10BA
					X		10D
					X		10E
+	O	+	+	O	+		11
+		+	+				11D
+							11C
		+	+	+			11E
		+	+	+			11F
O	O	O	O	O		O	12A
+	X	+	+	X		X	12B
O	O	O	O	O	O	O	13C

TABLE 2 (Rev.WRC-19)

**Characteristics for high altitude platform stations (HAPS) frequency assignments in the terrestrial services**

Item identifier	<i>1 - GENERAL CHARACTERISTICS OF THE HAPS</i>	Transmitting station in the bands listed in No. 5.388A for the application of No. 11.2	Receiving station in the bands listed in No. 5.388A for the application of No. 11.9	Transmitting station in the bands listed in Nos. 5.457, 5.537A, 5.530E, 5.532AA, 5.534A, 5.543B, 5.550D and 5.552A for the application of No. 11.2	Receiving station in the bands listed in Nos. 5.457, 5.534A, 5.543B, 5.550D and 5.552A for the application of No. 11.9	Item identifier
<b>GENERAL INFORMATION</b>						
1.B	the symbol of the notifying administration (see the Preface)	X	X	X	X	1.B
1.D	the provision code of the Radio Regulations under which the notice has been submitted	X	X	X	X	1.D
1.ID1	the unique identifier given by the administration to the station	X	X	X	X	1.ID1
<b>LOCATION OF THE STATION</b>						
1.4.a	the name by which the station is known	X	X	X	X	1.4.a
1.4.b	the code of the geographical area, above which the station is located (see the Preface)	X	X	X	X	1.4.b
1.4.c	the nominal geographical coordinates of the station Latitude and longitude are provided in degrees, minutes and seconds	X	X	X	X	1.4.c
1.4.h	the nominal altitude of the station above mean sea level, in metres	X	X	X	X	1.4.h
1.4.t	<b>Station location tolerances:</b>					1.4.t
1.4.t.1.a	the planned latitudinal tolerance northerly limit, using d.m.s units	X	X	X	X	1.4.t.1.a
1.4.t.1.b	the planned latitudinal tolerance southerly limit, using d.m.s units	X	X	X	X	1.4.t.1.b
1.4.t.2.a	the planned longitudinal tolerance easterly limit, using d.m.s units	X	X	X	X	1.4.t.2.a
1.4.t.2.b	the planned longitudinal tolerance westerly limit, using d.m.s units	X	X	X	X	1.4.t.2.b
1.4.t.3	the planned altitudinal tolerance, in metres	X	X	X	X	1.4.t.3
<b>COMPLIANCE WITH TECHNICAL OR OPERATIONAL LIMITS</b>						
1.14.b	a commitment that the HAPS does not exceed an out-of-band pfd of $-165 \text{ dB(W/(m}^2 \cdot 4 \text{ kHz))}$ at the Earth's surface in the bands 2 160-2 200 MHz in Region 2 and 2 170-2 200 MHz in Regions 1 and 3 (see Resolution 221 (Rev.WRC-07))	X				1.14.b

Item identifier	<i>1 - GENERAL CHARACTERISTICS OF THE HAPS</i>	Transmitting station in the bands listed in No. 5.388A for the application of No. 11.2	Receiving station in the bands listed in No. 5.388A for the application of No. 11.9	Transmitting station in the bands listed in Nos. 5.457, 5.537A, 5.530E, 5.532AA, 5.534A, 5.543B, 5.550D and 5.552A for the application of No. 11.2	Receiving station in the bands listed in Nos. 5.457, 5.534A, 5.543B, 5.550D and 5.552A for the application of No. 11.9	Item identifier
1.14.c	a commitment that the HAPS does not exceed the out-of-band pfd limits of $-165 \text{ dB(W/(m}^2 \cdot \text{MHz))}$ for angles of arrival ( $\theta$ ) less than $5^\circ$ above the horizontal plane, $-165 + 1.75 (\theta - 5) \text{ dB(W/(m}^2 \cdot \text{MHz))}$ for angles of arrival between $5^\circ$ and $25^\circ$ and $-130 \text{ dB(W/(m}^2 \cdot \text{MHz))}$ for angles of arrival between $25^\circ$ and $90^\circ$ (see Resolution <b>221 (Rev.WRC-07)</b> )	X				1.14.c
1.14.d	a commitment that the antenna pattern complies with the reference antenna pattern defined in <i>resolves</i> 1 of Resolution <b>150 (WRC-12)</b> Required in the band 6 560-6 640 MHz				+	1.14.d
1.14.e	a commitment that the aggregate power flux-density (pfd) of HAPS uplinks is limited to a maximum of $-183.9 \text{ dB(W/(m}^2 \cdot 4 \text{ kHz))}$ at any point in the geostationary arc. To meet this aggregate power flux-density (pfd) criterion, the maximum e.i.r.p. density value of a single HAPS gateway link towards the geostationary arc shall not exceed $-59.9 \text{ dB(W/4 kHz)}$ in any direction within $\pm 5$ degrees of the geostationary arc (see Resolution <b>150 (WRC-12)</b> ) Required in the band 6 560-6 640 MHz				+	1.14.e
1.14.f	a commitment that the e.i.r.p. density per HAPS in the bands 21.2-21.4 GHz and 22.21-22.5 GHz does not exceed $-0.76 \theta - 9.5 \text{ dB(W/100 MHz)}$ for angles of arrival between $-4.53^\circ$ and $35.5^\circ$ and $-36.5 \text{ dB(W/100MHz)}$ for angles of arrival between $35.5^\circ$ and $90^\circ$ (see Resolution <b>165 (WRC-19)</b> ) Required in the band 21.4-22 GHz			+		1.14.f
1.14.g	a commitment that the unwanted emission power flux-density produced by the HAPS does not exceed $-176 \text{ dB(W/(m}^2 \cdot 290 \text{ MHz))}$ for continuum observations, and $-192 \text{ dB(W/(m}^2 \cdot 250 \text{ kHz))}$ for spectral line observations in the band 22.21-22.5 GHz at an RAS station location at a height of 50 m (see Resolution <b>165 (WRC-19)</b> ) Required in the band 21.4-22 GHz			+		1.14.g



Item identifier	<i>1 - GENERAL CHARACTERISTICS OF THE HAPS</i>	Transmitting station in the bands listed in No. 5.388A for the application of No. 11.2	Receiving station in the bands listed in No. 5.388A for the application of No. 11.9	Transmitting station in the bands listed in Nos. 5.457, 5.537A, 5.530E, 5.532A, 5.534A, 5.543B, 5.550D and 5.552A for the application of No. 11.2	Receiving station in the bands listed in Nos. 5.457, 5.534A, 5.543B, 5.550D and 5.552A for the application of No. 11.9	Item identifier
1.14.h	<p>a commitment that, for the purpose of protecting the aeronautical mobile service operating in the band 21.2-21.5 GHz, the e.i.r.p. density per HAPS in the bands 21.4-21.5 GHz does not exceed 17.5 dB(W/100 MHz) (see Resolution <b>165 (WRC-19)</b>)</p> <p>Required in the band 21.4-22 GHz</p>			+		1.14.h
1.14.i	<p>a commitment that the e.i.r.p. density per HAPS in the band 23.6-24GHz does not exceed <math>-0.7714 \theta - 16.5</math> dB(W/200 MHz) for angles of arrival between <math>-4.53^\circ</math> and <math>35^\circ</math> and <math>-43.5</math> dB(W/200 MHz) for angles of arrival between <math>35^\circ</math> and <math>90^\circ</math> (see Resolution <b>166 (WRC-19)</b>)</p> <p>Required in the band 24.25-25.25 GHz</p>			+		1.14.i
1.14.j	<p>a commitment that the power flux-density produced by unwanted emissions from the HAPS does not exceed <math>-177</math> dB(W/m<sup>2</sup> · 400 MHz) for continuum observations and <math>-191</math> dB(W/(m<sup>2</sup> · 250 kHz)) for spectral line observations in the band 23.6-24 GHz at an RAS station location at the height of 50 m (see Resolution <b>166 (WRC-19)</b>)</p> <p>Required in the band 24.25-25.25 GHz</p>			+		1.14.j
1.14.k	<p>a commitment that the level of unwanted power density into the HAPS ground station antenna in the band 31.3-31.8 GHz does not exceed <math>-83</math> dB(W/200 MHz) under clear-sky conditions and may be increased under rainy conditions to mitigate fading due to rain, provided that the effective impact on the passive satellite does not exceed the impact under clear-sky conditions (see Resolution <b>167 (WRC-19)</b>)</p> <p>Required in the band 31-31.3 GHz</p>			+		1.14.k
1.14.l	<p>a commitment that the e.i.r.p. density per HAPS in the band 31.3-31.8 GHz does not exceed <math>-0 - 13.1</math> dB(W/200 MHz) for angles of arrival between <math>-4.53^\circ</math> and <math>22^\circ</math> and <math>-35.1</math> dB(W/200 MHz) for angles of arrival between <math>22^\circ</math> and <math>90^\circ</math> (see Resolution <b>167 (WRC-19)</b>)</p> <p>Required in the band 31-31.3 GHz</p>			+		1.14.l
1.14.m	<p>a commitment that the power flux-density produced by unwanted emissions from the HAPS ground station does not exceed <math>-141</math> dB(W/(m<sup>2</sup> · 500 MHz)) in the band 31.3-31.8 GHz at an RAS station location at the height of 50 m (see Resolution <b>167 (WRC-19)</b>)</p> <p>Required in the band 31-31.3 GHz</p>				+	1.14.m

Item identifier	<i>1 - GENERAL CHARACTERISTICS OF THE HAPS</i>	Transmitting station in the bands listed in No. 5.388A for the application of No. 11.2	Receiving station in the bands listed in No. 5.388A for the application of No. 11.9	Transmitting station in the bands listed in Nos. 5.457, 5.537A, 5.530E, 5.532AA, 5.534A, 5.543B, 5.550D and 5.552A for the application of No. 11.2	Receiving station in the bands listed in Nos. 5.457, 5.534A, 5.543B, 5.550D and 5.552A for the application of No. 11.9	Item identifier
1.14.n	a commitment that the power flux-density produced by unwanted emissions from the HAPS does not exceed $-171 \text{ dB(W/(m}^2 \cdot 500 \text{ MHz))}$ in the band 31.3-31.8 GHz at an RAS station location at the height of 50 m. (see Resolution <b>167 (WRC-19)</b> ) Required in the band 31-31.3 GHz			+		1.14.n
1.14.o	a commitment that the space research service (space-to-Earth) protection level of $-217 \text{ dB(W/Hz)}$ at the input of SRS receiver in the 37.0-38.0 GHz band with 0.001% exceedance due to atmospheric and precipitation effects, as referred to in the relevant ITU-R Recommendations, is not exceeded. (see Resolution <b>168 (WRC-19)</b> ) Required in the band 38-39.5 GHz			+	+	1.14.o
1.14.p	A commitment that the HAPS operation shall be in conformity with the Radio Regulations, including this Resolution. (see Resolution <b>168 (WRC-19)</b> ) Required in the band 38-39.5 GHz			+	+	1.14.p
1.14.q	a commitment that, upon receiving an unacceptable interference report with relevant justification on the exceedance of the limits set in this Resolution, the notifying administration for the HAPS system shall take the required action to eliminate the interference or reduce it an acceptable level. (see Resolution <b>168 (WRC-19)</b> ) Required in the band 38-39.5 GHz			+	+	1.14.q
1.14.r	a commitment that the separation distance between the nadir of the HAPS and a radio astronomy station operating in the band 48.94-49.04 GHz within the territory of another administration shall exceed 50 km (see Resolution <b>122 (Rev.WRC-19)</b> ) Required in the bands 47.2-47.5 GHz and 47.9-48.2 GHz			+		1.14.r
<b>COORDINATION AND AGREEMENT</b>						
1.11.a	the symbol of each administration with which coordination has been successfully effected, including where the agreement is to exceed the limits prescribed in the Radio Regulations Required if coordination is necessary and has been obtained pursuant to the relevant provisions of the Radio Regulations	+	+	+	+	1.11.a

Item identifier	<i>1 - GENERAL CHARACTERISTICS OF THE HAPS</i>	Transmitting station in the bands listed in No. 5.388A for the application of No. 11.2	Receiving station in the bands listed in No. 5.388A for the application of No. 11.9	Transmitting station in the bands listed in Nos. 5.457, 5.537A, 5.530E, 5.532AA, 5.534A, 5.543B, 5.550D and 5.552A for the application of No. 11.2	Receiving station in the bands listed in Nos. 5.457, 5.534A, 5.543B, 5.550D and 5.552A for the application of No. 11.9	Item identifier
<b>OPERATING ADMINISTRATION OR AGENCY</b>						
1.12.a	the symbol for the operating agency	O	O	O	O	1.12.a
1.12.b	the symbol for the address of the administration responsible for the station and to which communication should be sent on urgent matters regarding interference, quality of emissions and questions referring to the technical operation of the circuit (see Article 15)	X	X	X	X	1.12.b
<b>REMARKS</b>						
1.13.c	Remarks for assisting the Bureau in processing the notice	O	O	O	O	1.13.c

Item identifier	2 - CHARACTERISTICS TO BE PROVIDED FOR EACH INDIVIDUAL OR COMPOSITE HAPS ANTENNA BEAM	Transmitting station in the bands listed in No. 5.388A for the application of No. 11.2	Receiving station in the bands listed in No. 5.388A for the application of No. 11.9	Transmitting station in the bands listed in Nos. 5.457, 5.537A, 5.530E, 5.532AA, 5.534A, 5.543B, 5.550D and 5.552A for the application of No. 11.2	Receiving station in the bands listed in Nos. 5.457, 5.534A, 5.543B, 5.550D and 5.552A for the application of No. 11.9	Item identifier
	<b>IDENTIFICATION AND DIRECTION OF THE HAPS ANTENNA BEAM</b>					
2.1.a	the identification of the HAPS antenna beam	X	X	X	X	2.1.a
2.1.b	an indicator showing whether the antenna beam, under 2.1.a, is fixed or whether it is steerable and/or reconfigurable	X	X	X	X	2.1.b
2.1.c	an indicator showing whether the HAPS antenna tracks the service area	X		X		2.1.c
2.1.d	an indicator showing whether the antenna beam is individual or composite beam	X	X	X	X	2.1.d
	<b>ANTENNA CHARACTERISTICS</b>					
2.9.e	the height of the antenna above ground level, in metres, in the case of a HAPS transmitting ground station Required for an assignment in the bands shared with space services (space-to-Earth)				+	2.9.e
2.9.f	antenna diameter, in metres, in the case of a HAPS transmitting ground station Required in the bands 47.2-47.5 GHz and 47.9-48.2 GHz				+	2.9.f
2.9.g	the maximum co-polar isotropic gain	X	X	X	X	2.9.g
2.9.j	the measured radiation pattern of the antenna, the reference radiation pattern or the symbols in standard references to be used for coordination	X	X	X	X	2.9.j
2.9.gp	the co-polar antenna gain contours plotted on a map of the Earth's surface, preferably in a radial projection from the HAPS onto a plane perpendicular to the axis from the centre of the Earth to the HAPS The HAPS antenna gain contours shall be drawn as isolines of the isotropic gain, relative to the maximum antenna gain, when any of these contours is located either totally or partially outside the territory of the notifying administration The antenna gain contours shall include the effects of the planned longitudinal and latitudinal tolerance, planned altitudinal tolerance and the pointing accuracy of the antenna, taking into consideration the movement of the HAPS antenna boresight around the effective boresight area	X	X	X	X	2.9.gp

Item identifier	3 – CHARACTERISTICS TO BE PROVIDED FOR EACH FREQUENCY ASSIGNMENT FOR EACH INDIVIDUAL OR COMPOSITE HAPS ANTENNA BEAM	Transmitting station in the bands listed in No. 5.388A for the application of No. 11.2	Receiving station in the bands listed in No. 5.388A for the application of No. 11.9	Transmitting station in the bands listed in Nos. 5.457, 5.537A, 5.530E, 5.532AA, 5.534A, 5.543B, 5.550D and 5.552A for the application of No. 11.2	Receiving station in the bands listed in Nos. 5.457, 5.534A, 5.543B, 5.550DB and 5.552A for the application of No. 11.9	Item identifier
<b>ASSIGNED FREQUENCY</b>						
3.1.a	the assigned frequency, as defined in No. 1.148	X	X	X	X	3.1.a
3.1.b	the reference frequency, as defined in Article 1 Required if the modulation envelope is asymmetric	+	+	+	+	3.1.b
<b>DATE OF OPERATION</b>						
3.2.c	the date (actual or foreseen, as appropriate) of bringing the frequency assignment (new or modified) into use	X	X	X	X	3.2.c
<b>LOCATION OF THE ASSOCIATED ANTENNA(S)</b>						
3.5.c	the geographical coordinates of the ground station(s) in the fixed service Required in the bands 6 560-6 640 MHz and 25.25-27 GHz, 31-31.3 GHz, and 38-39.5 GHz; Required in the other bands, if neither the geographical coordinates of a given zone (3.c.a) nor a geographical area (3.5.d) nor a circular area (3.5.e and 3.5.f) are provided			+	+	3.5.c
<b>For an area in which associated transmitting/receiving ground station(s) operate:</b>						
3.5.c.a	the geographical coordinates of a given zone A minimum of six geographical coordinates are required, in degrees, minutes and seconds <i>Note</i> – For the fixed service in the bands 47.2-47.5 GHz and 47.9-48.2 GHz the geographical coordinates are provided for each of the UAC, SAC and if applicable RAC (see the most recent version of Recommendation ITU-R F.1500) Required if neither a circular area (3.5.e and 3.5.f) nor a geographical area (3.5.d) are provided	+	+	+	+	3.5.c.a
3.5.d	the code of the geographical area (see the Preface) <i>Note</i> – For the fixed service in the bands 47.2-47.5 GHz and 47.9-48.2 GHz separate geographical areas are provided for each of the UAC, SAC and if applicable RAC (see the most recent version of Recommendation ITU-R F.1500) Required if neither a circular area (3.5.e and 3.5.f) nor the geographical coordinates of a given zone (3.5.c.a) are provided	+	+	+	+	3.5.d

Item identifier	3 – CHARACTERISTICS TO BE PROVIDED FOR EACH FREQUENCY ASSIGNMENT FOR EACH INDIVIDUAL OR COMPOSITE HAPS ANTENNA BEAM	Transmitting station in the bands listed in No. 5.388A for the application of No. 11.2	Receiving station in the bands listed in No. 5.388A for the application of No. 11.9	Transmitting station in the bands listed in Nos. 5.457, 5.537A, 5.530E, 5.532AA, 5.534A, 5.543B, 5.550D and 5.552A for the application of No. 11.2	Receiving station in the bands listed in Nos. 5.457, 5.534A, 5.543B, 5.550DB and 5.552A for the application of No. 11.9	Item identifier
3.5.e	<p>the geographical coordinates of the centre of the circular area in which the associated ground station(s) are operating</p> <p>The latitude and longitude are provided in degrees, minutes and seconds</p> <p><i>Note</i> – For the fixed service in the bands 47.2-47.5 GHz and 47.9-48.2 GHz different centres of the circular area may be provided for the UAC, SAC and if applicable RAC (see the most recent version of Recommendation ITU-R F.1500)</p> <p>Required if neither a geographical area (3.5.d) or geographical coordinates of a given zone (3.5.c.a) are provided</p>	+	+	+	+	3.5.e
3.5.f	<p>the radius, in km, of the circular area</p> <p><i>Note</i> – For the fixed service in the bands 47.2-47.5 GHz and 47.9-48.2 GHz, a separate radius is provided for each of the UAC, SAC and if applicable RAC (see the most recent version of Recommendation ITU-R F.1500)</p> <p>Required if neither a geographical area (3.5.d) nor geographical coordinates of a given zone (3.5.c.a) are provided</p>	+	+	+	+	3.5.f
<b>CLASS OF STATION AND NATURE OF SERVICE</b>						
3.6.a	the class of station, using the symbols from the Preface	X	X	X	X	3.6.a
3.6.b	the nature of service, using the symbols from the Preface	X	X	X	X	3.6.b
<b>CLASS OF EMISSION AND NECESSARY BANDWIDTH</b> <i>(in accordance with Article 2 and Appendix 1)</i>						
3.7.a	the class of emission	X	X	X	X	3.7.a
3.7.b	the necessary bandwidth	X	X	X	X	3.7.b
<b>POWER CHARACTERISTICS OF THE TRANSMISSION</b>						
3.8	the symbol (X, Y or Z, as appropriate) describing the type of power (see Article 1) corresponding to the class of emission	X	X	X	X	3.8.
3.8.aa	<p>the power delivered to the antenna, in dBW, excluding the level of power control in 3.8.BA under clear-sky conditions</p> <p><i>Note</i> – For a receiving HAPS, the power delivered to the antenna refers to the associated transmitting ground station(s)</p>	X		X	X	3.8.aa
3.8.AB	the power density <sup>1</sup> averaged over the worst 1 MHz band delivered to the antenna under clear-sky conditions	X		X		3.8.AB

Item identifier	<p align="center"><b>3 – CHARACTERISTICS TO BE PROVIDED FOR EACH FREQUENCY ASSIGNMENT FOR EACH INDIVIDUAL OR COMPOSITE HAPS ANTENNA BEAM</b></p>	Transmitting station in the bands listed in No. 5.388A for the application of No. 11.2	Receiving station in the bands listed in No. 5.388A for the application of No. 11.9	Transmitting station in the bands listed in Nos. 5.457, 5.537A, 5.530E, 5.532AA, 5.534A, 5.543B, 5.550D and 5.552A for the application of No. 11.2	Receiving station in the bands listed in Nos. 5.457, 5.534A, 5.543B, 5.550DB and 5.552A for the application of No. 11.9	Item identifier
3.8.BA	the range of power control, in dB <i>Note</i> – For a receiving HAPS, the power control refers to its use by the associated transmitting ground station(s) In the case of a transmitting HAPS, required in the bands, 21.4-22 GHz, 24.25-25.25 GHz, 27-27.5 GHz, 31-31.3 GHz, 38-39.5 GHz, 47.2-47.5 GHz and 47.9-48.2 GHz In the case of a receiving HAPS, required in the bands 47.2-47.5 GHz and 47.9-48.2 GHz	X		+	+	3.8.BA
	<b>POLARIZATION AND RECEIVING SYSTEM NOISE TEMPERATURE</b>					
3.9.d	the code indicating the type of polarization (see the Preface)	X	X	X	X	3.9.d
3.9.j	the reference radiation pattern of the associated ground station(s) Required in the bands 47.2-47.5 GHz and 47.9-48.2 GHz			+	+	3.9.j
3.9.k	the lowest total receiving system noise temperature, in kelvins, referred to the output of the receiving antenna		X		X	3.9.k
	<b>HOURS OF OPERATION</b>					
3.10.b	the regular hours of operation (in hours and minutes from ... to ...) of the frequency assignment, in UTC	X	X	X	X	3.10.b

## ANNEX 2

## Characteristics of satellite networks, earth stations or radio astronomy stations<sup>2</sup> (Rev.WRC-12)

### Information relating to the data listed in the following Tables

In many cases the data requirements involve the use of standard symbols in submissions to the Radiocommunication Bureau. These standard symbols may be found in the “Preface to the BR International Frequency Information Circular”, (BR IFIC) (Space Services), the ITU-R webpage and the Space Radiocommunication Stations on DVD-ROM. (In the Table, this is referred to simply as “the Preface”.) Information relating to the provision of data may also be found in ITU-R Recommendations, for example, information on the mask data can be found in the most recent version of Recommendation ITU-R S.1503, and the most recent version of Recommendation ITU-R SM.1413 provides general information related to submission of data.

### Key to the symbols used in Tables A, B, C and D

X	Mandatory information
+	Mandatory under the conditions specified in Column 2
O	Optional information
C	Mandatory if used as a basis to effect coordination with another administration
	The data item is not applicable to the corresponding notice

---

<sup>2</sup> The Radiocommunication Bureau shall develop and keep up-to-date forms of notice to meet fully the statutory provisions of this Appendix and related decisions of future conferences. Additional information on the items listed in this Annex together with an explanation of the symbols is to be found in the Preface to the BR IFIC (Space Services). (WRC-12)



**Reading the Appendix 4 Tables**

The rules used to link the sign with the text are based on the Table column headings covering specific procedures and specific services.

1 If any data item has a condition attached to it, then it has a “+”.

A.6.c	if agreement has been reached, the related provision code (see the Preface)	+	A.6.c
C.8.f.1	the space station’s nominal equivalent isotropically radiated power(s) (e.i.r.p.) on the beam axis Required only for a space-to-space link	+	C.8.f.1

2 Data items grouped under a common subheading that limits the range of procedures, services or frequency bands have a “X” as the conditional nature is shown in the subheading title.

A.4.b.5	<b>For space stations operating in a frequency band subject to the provisions of Nos. 9.11A, 9.12 or 9.12A, the data elements to characterize properly the orbital statistics of the non-geostationary-satellite system:</b>	X	A.4.b.5
A.4.b.5.a	the right ascension of the ascending node ( $\Omega_j$ ) for the $j$ -th orbital plane, measured counter-clockwise in the equatorial plane from the direction of the vernal equinox to the point where the satellite makes its South-to-North crossing of the equatorial plane ( $0^\circ \leq \Omega_j < 360^\circ$ )		A.4.b.5.a

3 “In the case of”, followed by a reference to the column heading, is used as shown below when the associated conditions are different for individual columns, or if the indication is not the same across all applicable columns.

A.3.a	the symbol for the operating administration or agency (see the Preface) that is in operational control of the space station, earth station or radio astronomy station In the case of Appendix 30B, required only for notification under Article 8	X	+	A.3.a
-------	------------------------------------------------------------------------------------------------------------------------------------------------------------------------------------------------------------------------------------------------------	---	---	-------

**Footnotes to Tables A, B, C and D**

<sup>1</sup> Not required for coordination under No. 9.7A.

<sup>2</sup> In calculating the maximum power density per Hz, see the most recent version of Recommendation ITU-R SF.675. For carriers below 15 GHz, the power density is averaged over the worst 4 kHz band. For carriers at or above 15 GHz, the power density is averaged over the worst 1 MHz band. (WRC-12)

**Table of characteristics to be submitted for space and radio astronomy services**  
(Rev.WRC-12)

**TABLE A**  
**GENERAL CHARACTERISTICS OF THE SATELLITE NETWORK OR SYSTEM,**  
**EARTH STATION OR RADIO ASTRONOMY STATION** (Rev.WRC-19)

Items in Appendix	<p><i>A - GENERAL CHARACTERISTICS OF THE SATELLITE NETWORK OR SYSTEM, EARTH STATION OR RADIO ASTRONOMY STATION</i></p>
<b>A.1</b>	<b>IDENTITY OF THE SATELLITE NETWORK OR SYSTEM, EARTH STATION OR RADIOASTRONOMY STATION</b>
A.1.a	the identity of the satellite network or system
A.1.b	the beam identification In the case of Appendix 30 or 30A, required only for modification, suppression or notification of Plan assignments In the case of Appendix 30B, required only for a network derived from the Allotment Plan
A.1.c	<b>Identity of the earth station or radio astronomy station:</b>
A.1.c.1	the type of earth station (specific or typical)
A.1.c.2	the name of the station
A.1.c.3	<b>For a specific earth station or radio astronomy station:</b>
A.1.c.3.a	the country or geographical area in which the station is located, using the symbols from the Preface
A.1.c.3.b	the geographical coordinates of each transmitting or receiving antenna site constituting the station (latitude and longitude in degrees and minutes) For a specific earth station, seconds are to be provided if the coordination area of the earth station overlaps the territory of another administration
A.1.f	<b>Administration and intergovernmental organization symbol:</b>
A.1.f.1	the symbol of the notifying administration (see the Preface)
A.1.f.2	if the notice is submitted by the notifying administration in association with other administrations, the symbols of each of the administrations (see the Preface)
A.1.f.3	if the notice is submitted on behalf of an intergovernmental satellite organization, the symbol of that organization (see the Preface)
A.1.g	indicator showing that the non-GSO satellite system is planned to be operated in accordance with Resolution 32 (WRC-19) Required for advance publication and notification
A.1.g.1	<b>Not used</b>
A.1.g.2	<b>Not used</b>

Advance publication of a geostationary-satellite network	Advance publication of a non-geostationary-satellite network or system subject to coordination under Section II of Article 9	Advance publication of a non-geostationary-satellite network or system not subject to coordination under Section II of Article 9	Notification or coordination of a geostationary-satellite network (including space operation functions under Article 2A of Appendices 30 or 30A)	Notification or coordination of a non-geostationary-satellite network or system	Notification or coordination of an earth station (including notification under Appendices 30A or 30B)	Notice for a satellite network in the broadcasting-satellite service under Appendix 30 (Articles 4 and 5)	Notice for a satellite network (feeder-link) under Appendix 30A (Articles 4 and 5)	Notice for a satellite network in the fixed-satellite service under Appendix 30B (Articles 6 and 8)	Items in Appendix	Radio astronomy
									A.1	
X	X	X	X	X		X	X	X	A.1.a	
						+	+	+	A.1.b	
									A.1.e	
					X				A.1.e.1	
					X				A.1.e.2	X
									A.1.e.3	
					X				A.1.e.3.a	X
					X				A.1.e.3.b	X
									A.1.f	
X	X	X	X	X	X	X	X	X	A.1.f.1	X
+	+	+	+	+		+	+	+	A.1.f.2	
+	+	+	+	+		+	+	+	A.1.f.3	
		X		+					A.1.g	
									A.1.g.1	
									A.1.g.2	

Items in Appendix	<i>A - GENERAL CHARACTERISTICS OF THE SATELLITE NETWORK OR SYSTEM, EARTH STATION OR RADIO ASTRONOMY STATION</i>
<b>A.2</b>	<b>DATE OF BRINGING INTO USE</b>
A.2.a	<p>the date (actual or foreseen, as appropriate) of bringing the frequency assignment (new or modified) into use</p> <p>For a frequency assignment to a GSO space station, including frequency assignments in Appendices <b>30</b>, <b>30A</b> and <b>30B</b>, the date of bringing into use is as defined in Nos. <b>11.44B</b> and <b>11.44.2</b></p> <p>For a frequency assignment to a non-GSO space station, the date of bringing into use is as defined in Nos. <b>11.44C</b>, <b>11.44D</b>, <b>11.44E</b> and <b>11.44.2</b>, as applicable</p> <p>For a frequency assignment to a non-GSO satellite system with a short-duration mission, the date of bringing into use is as defined in Resolution <b>32 (WRC-19)</b></p> <p>Whenever the assignment is changed in any of its basic characteristics (except for a change under A.1.a), the date to be given shall be that of the latest change (actual or foreseen, as appropriate)</p> <p>Required only for notification and, in the case of Appendices <b>30</b> and <b>30A</b>, also for simultaneous submissions for modifications to the Region 2 Plan or entry into the Regions 1 and 3 List under Article 4 and notification under Article 5, and, in the case of Appendix <b>30B</b>, also for simultaneous submissions for entry into the List under § 6.17 and notification under § 8.1</p>
A.2.b	for a space station, the period of validity of the frequency assignments (see Resolution <b>4 (Rev.WRC-03)</b> and Resolution <b>32 (WRC-19)</b> , as appropriate)
A.2.c	the date (actual or foreseen, as appropriate) on which reception of the frequency band begins or on which any of the basic characteristics are modified
<b>A.3</b>	<b>OPERATING ADMINISTRATION OR AGENCY</b>
A.3.a	the symbol for the operating administration or agency (see the Preface) that is in operational control of the space station, earth station or radio astronomy station
A.3.b	the symbol for the address of the administration (see the Preface) to which communication should be sent on urgent matters regarding interference, quality of emissions and questions referring to the technical operation of the network or system or station (see Article <b>15</b> )
<b>A.4</b>	<b>ORBITAL INFORMATION</b>
A.4.a	<b>For a space station onboard a geostationary-satellite:</b>
A.4.a.1	the nominal geographical longitude on the geostationary-satellite orbit (GSO)
A.4.a.2	<b>Orbital tolerances</b>
A.4.a.2.a	the planned longitudinal tolerance easterly limit
A.4.a.2.b	the planned longitudinal tolerance westerly limit
A.4.a.2.c	the planned inclination excursion
A.4.a.4	<b>Not used</b>
A.4.a.4.a	<b>Not used</b>
A.4.a.4.b	<b>Not used</b>

Advance publication of a geostationary-satellite network	Advance publication of a non-geostationary-satellite network or system subject to coordination under Section II of Article 9	Advance publication of a non-geostationary-satellite network or system not subject to coordination under Section II of Article 9	Notification or coordination of a geostationary-satellite network (including space operation functions under Article 2A of Appendices 30 or 30A)	Notification or coordination of a non-geostationary-satellite network or system	Notification or coordination of an earth station (including notification under Appendices 30A or 30B)	Notice for a satellite network in the broadcasting-satellite service under Appendix 30 (Articles 4 and 5)	Notice for a satellite network (feeder-link) under Appendix 30A (Articles 4 and 5)	Notice for a satellite network in the fixed-satellite service under Appendix 30B (Articles 6 and 8)	Items in Appendix	Radio astronomy
									A.2	
			+						A.2.a	
		X	X	X					A.2.b	
									A.2.c	X
									<b>A.3</b>	
		X	X	X	X	X	X	X	A.3.a	X
		X	X	X	X	X	X	X	A.3.b	X
									<b>A.4</b>	
									A.4.a	
X			X			X	X	X	A.4.a.1	
									A.4.a.2	
			X			X	X	X	A.4.a.2.a	
			X			X	X	X	A.4.a.2.b	
			X					X	A.4.a.2.c	
									A.4.a.4	
									A.4.a.4.a	
									A.4.a.4.b	

Items in Appendix	<b>A - GENERAL CHARACTERISTICS OF THE SATELLITE NETWORK OR SYSTEM, EARTH STATION OR RADIO ASTRONOMY STATION</b>
A.4.b	<b>For space station(s) onboard non-geostationary satellite(s):</b>
A.4.b.1	the number of orbital planes
A.4.b.1.a	indicator of whether the non-geostationary-satellite system represents a “constellation”, where the term “constellation” describes a satellite system, for which the relative distribution of the orbital planes and satellites is defined  <i>Note</i> – Non-geostationary-satellite systems in frequency bands subject to the provisions of Nos. <b>9.12, 9.12A, 22.5C, 22.5D, 22.5F or 22.5L</b> are always considered as “constellations”
A.4.b.1.b	indicator of whether all the orbital planes identified under A.4.b.1 describe a) a single configuration where all frequency assignments to the satellite system will be in use or b) multiple configurations that are mutually exclusive where a sub-set of the frequency assignments to the satellite system will be in use on one of the sub-sets of orbital parameters to be determined at the notification and recording stage of the satellite system  Required only for the: 1) advance publication information for a non-geostationary-satellite system representing a constellation (A.4.b.1.a), and 2) coordination request for non-geostationary-satellite systems
A.4.b.1.c	if the orbital planes identified under A.4.b.1 describe multiple mutually exclusive configurations, identification of the number of sub-sets of orbital characteristics that are mutually exclusive  Required only for the: 1) advance publication information for a non-geostationary-satellite system representing a constellation (A.4.b.1.a), and 2) coordination request for non-geostationary-satellite systems
A.4.b.1.d	if the orbital planes identified under A.4.b.1 describe multiple mutually exclusive configurations, identification of the orbital planes’ id numbers that are associated with each of the mutually exclusive configurations  Required only for the: 1) advance publication information for a non-geostationary-satellite system representing a constellation (A.4.b.1.a), and 2) coordination request for non-geostationary-satellite systems
A.4.b.2	the reference body code
A.4.b.3	<b>For space stations of a non-geostationary fixed-satellite service system operating in the frequency band 3 400-4 200 MHz:</b>
A.4.b.3.a	the maximum number of space stations ( $N_N$ ) in a non-geostationary-satellite system simultaneously transmitting on a co-frequency basis in the fixed-satellite service in the Northern Hemisphere
A.4.b.3.b	the maximum number of space stations ( $N_S$ ) in a non-geostationary-satellite system simultaneously transmitting on a co-frequency basis in the fixed-satellite service in the Southern Hemisphere
A.4.b.4	<b>For each orbital plane, where the Earth is the reference body:</b>
A.4.b.4.a	the angle of inclination ( $i_j$ ) of the orbital plane with respect to the Earth’s equatorial plane ( $0^\circ \leq i_j < 180^\circ$ )

Advance publication of a geostationary-satellite network	Advance publication of a non-geostationary-satellite network or system subject to coordination under Section II of Article 9	Advance publication of a non-geostationary-satellite network or system not subject to coordination under Section II of Article 9	Notification or coordination of a geostationary-satellite network (including space operation functions under Article 2A of Appendices 30 or 30A)	Notification or coordination of a non-geostationary-satellite network or system	Notification or coordination of an earth station (including notification under Appendices 30A or 30B)	Notice for a satellite network in the broadcasting-satellite service under Appendix 30 (Articles 4 and 5)	Notice for a satellite network (feeder-link) under Appendix 30A (Articles 4 and 5)	Notice for a satellite network in the fixed-satellite service under Appendix 30B (Articles 6 and 8)	Items in Appendix	Radio astronomy
								A.4.b		
		X		X				A.4.b.1		
		X		X				A.4.b.1.a		
		+		+				A.4.b.1.b		
		+		+				A.4.b.1.c		
		+		+				A.4.b.1.d		
	X	X		X				A.4.b.2		
								A.4.b.3		
		X		X				A.4.b.3.a		
		X		X				A.4.b.3.b		
								A.4.b.4		
		X		X				A.4.b.4.a		



Items in Appendix	<b>A - GENERAL CHARACTERISTICS OF THE SATELLITE NETWORK OR SYSTEM, EARTH STATION OR RADIO ASTRONOMY STATION</b>
A.4.b.4.b	the number of satellites in the orbital plane
A.4.b.4.c	the period
A.4.b.4.d	the altitude, in kilometres, of the apogee of the space station
A.4.b.4.e	the altitude, in kilometres, of the perigee of the space station
A.4.b.4.f	the minimum altitude of the space station above the surface of the Earth at which any satellite transmits
A.4.b.4.g	<p>the right ascension of the ascending node (<math>\Omega_j</math>) for the <math>j</math>-th orbital plane, measured counter-clockwise in the equatorial plane from the direction of the vernal equinox to the point where the satellite makes its South-to-North crossing of the equatorial plane (<math>0^\circ \leq \Omega_j &lt; 360^\circ</math>), determined at the reference time indicated in A.4.b.4.k and A.4.b.4.l</p> <p>Required only for space stations operating in a frequency band subject to the provisions of Nos. <b>9.12</b> or <b>9.12A</b></p> <p><i>Note</i> – All satellites in all orbital planes must use the same reference time. If no reference time is provided in A.4.b.4.k and A.4.b.4.l, it is assumed to be <math>t = 0</math></p>
A.4.b.4.h	<p>the initial phase angle (<math>\omega_i</math>) of the <math>i</math>-th satellite in its orbital plane at reference time <math>t = 0</math>, measured from the point of the ascending node (<math>0^\circ \leq \omega_i &lt; 360^\circ</math>)</p> <p>Required only in the case of a non-geostationary-satellite system representing a “constellation” (A.4.b.1.a), and to be specified in:</p> <ol style="list-style-type: none"> <li>1) the advance publication information, for any frequency assignment not subject to the provisions of Section II of Article 9</li> <li>2) the coordination request, for any frequency assignment subject to the provisions of Nos. <b>9.12</b>, <b>9.12A</b>, <b>22.5C</b>, <b>22.5D</b>, <b>22.5F</b> or <b>22.5L</b></li> <li>3) the notification, in all cases</li> </ol> <p><i>Note</i> – The initial phase angle is the argument of perigee plus the true anomaly</p>
A.4.b.4.i	<p>the argument of perigee (<math>\omega_p</math>), measured in the orbital plane, in the direction of motion, from the ascending node to the perigee (<math>0^\circ \leq \omega_p &lt; 360^\circ</math>)</p> <p>Required only for orbits of a “constellation” (A.4.b.1.a) where the altitudes of apogee and perigee (A.4.b.4.d and A.4.b.4.e) are different, and to be specified in:</p> <ol style="list-style-type: none"> <li>1) the advanced publication information, for any frequency assignment not subject to the provisions of Section II of Article 9</li> <li>2) the coordination request, for any frequency assignment subject to the provisions of Nos. <b>9.12</b>, <b>9.12A</b>, <b>22.5C</b>, <b>22.5D</b>, <b>22.5F</b> or <b>22.5L</b></li> <li>3) the notification, in all cases</li> </ol>

Advance publication of a geostationary-satellite network	Advance publication of a non-geostationary-satellite network or system subject to coordination under Section II of Article 9	Advance publication of a non-geostationary-satellite network or system not subject to coordination under Section II of Article 9	Notification or coordination of a geostationary-satellite network (including space operation functions under Article 2A of Appendices 30 or 30A)	Notification or coordination of a non-geostationary-satellite network or system	Notification or coordination of an earth station (including notification under Appendices 30A or 30B)	Notice for a satellite network in the broadcasting-satellite service under Appendix 30 (Articles 4 and 5)	Notice for a satellite network (feeder-link) under Appendix 30A (Articles 4 and 5)	Notice for a satellite network in the fixed-satellite service under Appendix 30B (Articles 6 and 8)	Items in Appendix	Radio astronomy
		X		X				A.4.b.4.b		
		X		X				A.4.b.4.c		
		X		X				A.4.b.4.d		
		X		X				A.4.b.4.e		
		X		X				A.4.b.4.f		
								A.4.b.4.g		
				+						
		+		+				A.4.b.4.h		
		+		+				A.4.b.4.i		

Items in Appendix	<b>A - GENERAL CHARACTERISTICS OF THE SATELLITE NETWORK OR SYSTEM, EARTH STATION OR RADIO ASTRONOMY STATION</b>
A.4.b.4.j	<p>the longitude of the ascending node (<math>\theta_j</math>) for the <math>j</math>-th orbital plane, measured counter-clockwise in the equatorial plane from the Greenwich meridian to the point where the satellite orbit makes its South-to-North crossing of the equatorial plane (<math>0^\circ \leq \theta_j &lt; 360^\circ</math>)</p> <p>Required only for orbits of a “constellation” (A.4.b.1.a), and to be specified in:</p> <ol style="list-style-type: none"> <li>1) the advance publication information, for any frequency assignment not subject to the provisions of Section II of Article 9</li> <li>2) the coordination request, for any frequency assignment subject to the provisions of Nos. <b>9.12, 9.12A, 22.5C, 22.5D, 22.5F or 22.5L</b></li> <li>3) the notification, in all cases</li> </ol> <p><i>Note</i> – All satellites in all orbital planes must use the same reference time. If no reference time is provided in A.4.b.4.k and A.4.b.4.l, it is assumed to be <math>t = 0</math></p>
A.4.b.4.k	the date (day:month:year) at which the satellite is at the location defined by the longitude of the ascending node ( $\theta_j$ ) (see Note under A.4.b.4.j)
A.4.b.4.l	the time (hours:minutes) at which the satellite is at the location defined by the longitude of the ascending node ( $\theta_j$ ) (see Note under A.4.b.4.j)
A.4.b.4.m	indicator of whether the space station uses sun-synchronous orbit or not Required only in frequency bands not subject to the provisions of Nos <b>9.12 or 9.12A</b>
A.4.b.4.n	if the space station uses sun-synchronous orbit (A.4.b.4.m), indicator of whether the space station references the local time of the ascending node (solar local time when the space station is crossing the equatorial plane in the South-North direction in hours:minutes format) or the descending node (solar local time when the space station is crossing the equatorial plane in the North-South direction in hours:minutes format)
A.4.b.4.o	if the space station uses sun-synchronous orbit (A.4.b.4.m), the local time of the ascending (or descending, per A.4.b.4.n) node (solar local time when the space station is crossing the equatorial plane in the South-North (or North-South) direction in hours:minutes format)
A.4.b.5	<b>Not used</b>
A.4.b.6	<b>For space stations operating in a frequency band subject to Nos. 22.5C, 22.5D, 22.5F or 22.5L, additional data elements to characterize properly the orbital operation of the non-geostationary-satellite system:</b>
A.4.b.6 bis	an indicator showing whether the set of operating parameters is provided in A.14.d (extended set of operating parameters) or provided in A.4.b.6.a and A.4.b.7 (limited set of operating parameters)
A.4.b.6.a	<b>For each range of latitudes:</b> the limited set of operating parameters
A.4.b.6.a.1	the maximum number of non-geostationary satellites transmitting with overlapping frequencies to a given location
A.4.b.6.a.2	the associated start of the latitude range
A.4.b.6.a.3	the associated end of the latitude range



Items in Appendix	<i>A - GENERAL CHARACTERISTICS OF THE SATELLITE NETWORK OR SYSTEM, EARTH STATION OR RADIO ASTRONOMY STATION</i>
A.4.b.6.b	<b>Not used</b>
A.4.b.6.c	an indicator showing whether the space station uses station-keeping to maintain a repeating ground track
A.4.b.6.d	if the space station uses station-keeping to maintain a repeating ground track, the time in seconds that it takes for the constellation to return to its starting position, i.e. such that all satellites are in the same location with respect to the Earth and each other
A.4.b.6.e	an indicator showing whether the space station should be modelled with a specific precession rate of the ascending node of the orbit instead of the $J_2$ term
A.4.b.6.f	if the space station is to be modelled with a specific precession rate of the ascending node of the orbit instead of the $J_2$ term, the precession rate in degrees/day, measured counter-clockwise in the equatorial plane
A.4.b.6.g	<b>Not used</b>
A.4.b.6.h	<b>Not used</b>
A.4.b.6.i	<b>Not used</b>
A.4.b.6.j	the longitudinal tolerance of the longitude of the ascending node
A.4.b.7	<b>For space stations operating in a frequency band subject to Nos. 22.5C, 22.5D, 22.5F or 22.5L, the data elements to characterize properly the performance of the non-geostationary-satellite system: to be provided, if A.4.b.6bis indicates the limited set of operating parameters</b>
A.4.b.7.a	the maximum number of non-geostationary satellites receiving simultaneously with overlapping frequencies from the associated earth stations within a given cell
A.4.b.7.b	the average number of associated earth stations with overlapping frequencies per square kilometre within a cell
A.4.b.7.c	the average distance, in kilometres, between co-frequency cells
A.4.b.7.cbis	the minimum elevation angle at which any associated earth station can transmit to or receive from a non-geostationary satellite
A.4.b.7.d	<b>For the exclusion zone about the geostationary-satellite orbit:</b>
A.4.b.7.d.1	the type of zone (based on topocentric angle or satellite-based angle for establishing the exclusion zone)
A.4.b.7.d.2	if the zone is based on a topocentric angle or a satellite-based angle, the width of the zone, in degrees
A.4.b.7.d.3	<b>Not used</b>
A.4.c	<b>For an earth station:</b>
A.4.c.1	the identity of the associated space station(s) with which communication is to be established
A.4.c.2	if communication is to be established with a geostationary space station, its orbital position
<b>A.5</b>	<b>COORDINATIONS</b>
A.5.a.1	the symbol of any administration (see the Preface) with which coordination has been successfully effected Required only for notification
A.5.a.1.a	the name of satellite network or system with which coordination has been successfully effected for all notified assignments

Advance publication of a geostationary-satellite network	Advance publication of a non-geostationary-satellite network or system subject to coordination under Section II of Article 9	Advance publication of a non-geostationary-satellite network or system not subject to coordination under Section II of Article 9	Notification or coordination of a geostationary-satellite network (including space operation functions under Article 2A of Appendices 30 or 30A)	Notification or coordination of a non-geostationary-satellite network or system	Notification or coordination of an earth station (including notification under Appendices 30A or 30B)	Notice for a satellite network in the broadcasting-satellite service under Appendix 30 (Articles 4 and 5)	Notice for a satellite network (feeder-link) under Appendix 30A (Articles 4 and 5)	Notice for a satellite network in the fixed-satellite service under Appendix 30B (Articles 6 and 8)	Items in Appendix	Radio astronomy
								A.4.b.6.b		
				X				A.4.b.6.c		
				+				A.4.b.6.d		
				X				A.4.b.6.e		
				+				A.4.b.6.f		
								A.4.b.6.g		
								A.4.b.6.h		
								A.4.b.6.i		
				X				A.4.b.6.j		
								A.4.b.7		
				+				A.4.b.7.a		
				+				A.4.b.7.b		
				+				A.4.b.7.c		
				+				A.4.b.7.cbis		
								A.4.b.7.d		
				+				A.4.b.7.d.1		
				+				A.4.b.7.d.2		
								A.4.b.7.d.3		
								A.4.c		
					X			A.4.c.1		
					+			A.4.c.2		
									A.5	
			+	+	+1			A.5.a.1		
			O					A.5.a.1.a		

Items in Appendix	<b>A - GENERAL CHARACTERISTICS OF THE SATELLITE NETWORK OR SYSTEM, EARTH STATION OR RADIO ASTRONOMY STATION</b>
A.5.a.2	the symbol of any intergovernmental organization (see the Preface) with which coordination has been successfully effected Required only for notification
A.5.a.2.a	the name of satellite network or system with which coordination has been successfully effected for all notified assignments
A.5.b.1	the symbol of any administration (see the Preface) with which coordination has been sought but not completed
A.5.b.2	the symbol of any intergovernmental organization (see the Preface) with which coordination has been sought but not completed
A.5.c	if either A.5.a.1 (and A.5.a.2) or A.5.b.1 (and A.5.b.2) has been supplied, the related provision code (see the Preface) under which coordination has been sought or completed
<b>A.6</b>	<b>AGREEMENTS</b>
A.6.a	if appropriate, the symbol of any administration or administration representing a group of administrations (see the Preface) with which agreement has been reached, including where the agreement is to exceed the limits prescribed in these Regulations
A.6.a.1	the name of satellite network or system with which agreement has been reached for all notified assignments
A.6.b	if appropriate, the symbol of any intergovernmental organization (see the Preface) with which agreement has been reached, including where the agreement is to exceed the limits prescribed in these Regulations
A.6.b.1	the name of satellite network or system with which agreement has been reached for all notified assignments
A.6.c	if agreement has been reached, the related provision code (see the Preface)
<b>A.7</b>	<b>SPECIFIC EARTH STATION OR RADIO ASTRONOMY STATION SITE CHARACTERISTICS</b>
A.7.a	horizon elevation angle and distance
A.7.a.1	the horizon elevation angle, in degrees, for each azimuth around the earth station
A.7.a.2	the distance, in kilometres, from the earth station to the horizon for each azimuth around the earth station
A.7.b	minimum/maximum antenna main beam elevation
A.7.b.1	the planned minimum angle of elevation of the antenna's main beam axis, in degrees, from the horizontal plane For determining the minimum elevation angle of an earth station, due regard should be given to possible inclined-orbit operation of the associated geostationary space station Required only for earth stations operating with geostationary satellite
A.7.b.2	the planned maximum angle of elevation of the antenna's main beam axis, in degrees, from the horizontal plane Required only for earth stations operating with geostationary satellite

Advance publication of a geostationary-satellite network	Advance publication of a non-geostationary-satellite network or system subject to coordination under Section II of Article 9	Advance publication of a non-geostationary-satellite network or system not subject to coordination under Section II of Article 9	Notification or coordination of a geostationary-satellite network (including space operation functions under Article 2A of Appendices 30 or 30A)	Notification or coordination of a non-geostationary-satellite network or system	Notification or coordination of an earth station (including notification under Appendices 30A or 30B)	Notice for a satellite network in the broadcasting-satellite service under Appendix 30 (Articles 4 and 5)	Notice for a satellite network (feeder-link) under Appendix 30A (Articles 4 and 5)	Notice for a satellite network in the fixed-satellite service under Appendix 30B (Articles 6 and 8)	Items in Appendix	Radio astronomy
			+	+	+1				A.5.a.2	
			O						A.5.a.2.a	
			O	O	O				A.5.b.1	
			O	O					A.5.b.2	
			+	+	+1				A.5.c	
									<b>A.6</b>	
			+	+	+1	+	+	+	A.6.a	
			O						A.6.a.1	
			+	+	+1	+	+	+	A.6.b	
			O						A.6.b.1	
			+	+	+1	+	+	+	A.6.c	
									<b>A.7</b>	
					+1				A.7.a	
					O				A.7.a.1	
									A.7.a.2	
									A.7.b	
					+1				A.7.b.1	X
									A.7.b.2	X



Items in Appendix	<i>A - GENERAL CHARACTERISTICS OF THE SATELLITE NETWORK OR SYSTEM, EARTH STATION OR RADIO ASTRONOMY STATION</i>
A.7.c	operating azimuths of antenna main beam
A.7.c.1	the start azimuth for the planned range of operating azimuthal angles for the antenna's main beam axis, in degrees, clockwise from True North For determining the start azimuth of an earth station, due regard should be given to possible inclined-orbit operation of the associated geostationary space station Required only for earth stations operating with geostationary satellite
A.7.c.2	the end azimuth for the planned range of operating azimuthal angles for the antenna's main beam axis, in degrees, clockwise from True North For determining the end azimuth of an earth station, due regard should be given to possible inclined-orbit operation of the associated geostationary space station Required only for earth stations operating with geostationary satellite
A.7.d	the altitude, in metres, of the antenna above mean sea level
A.7.e	the minimum angle of elevation of the antenna's main beam axis, in degrees, from the horizontal plane for each azimuth around the earth station Required only for earth stations operating with non-geostationary space stations
A.7.f	the antenna diameter, in metres Required only for fixed-satellite service earth stations operating in the frequency bands 13.75-14 GHz, 14.5-14.75 GHz (in countries listed in Resolution <b>163 (WRC-15)</b> not for feeder links for the broadcasting-satellite service), 14.5-14.8 GHz (in countries listed in Resolution <b>164 (WRC-15)</b> not for feeder links for the broadcasting-satellite service), 24.65-25.25 GHz (Region 1) and 24.65-24.75 GHz (Region 3)
<b>A.8</b>	<b>Not used</b>
<b>A.9</b>	<b>Not used</b>
<b>A.10</b>	<b>EARTH STATION COORDINATION AREA DIAGRAMS</b>
A.10.a	the diagrams shall be drawn to an appropriate scale, indicating, for both transmission and reception, the location of the earth station and its associated coordination areas, or the coordination area related to the service area in which it is intended to operate the mobile earth station Required only for notification
<b>A.11</b>	<b>REGULAR HOURS OF OPERATION</b>
A.11.a	the start time UTC
A.11.b	the stop time UTC
<b>A.12</b>	<b>RANGE OF AUTOMATIC GAIN CONTROL, in dB</b>

Advance publication of a geostationary-satellite network	Advance publication of a non-geostationary-satellite network or system subject to coordination under Section II of Article 9	Advance publication of a non-geostationary-satellite network or system not subject to coordination under Section II of Article 9	Notification or coordination of a geostationary-satellite network (including space operation functions under Article 2A of Appendices 30 or 30A)	Notification or coordination of a non-geostationary-satellite network or system	Notification or coordination of an earth station (including notification under Appendices 30A or 30B)	Notice for a satellite network in the broadcasting-satellite service under Appendix 30 (Articles 4 and 5)	Notice for a satellite network (feeder-link) under Appendix 30A (Articles 4 and 5)	Notice for a satellite network in the fixed-satellite service under Appendix 30B (Articles 6 and 8)	Items in Appendix	Radio astronomy
									A.7.c	
					+1				A.7.c.1	X
					+1				A.7.c.2	X
					+1				A.7.d	
					+				A.7.e	
					+1				A.7.f	
									A.8	
									A.9	
									A.10	
					+				A.10.a	
									A.11	
						X	X		A.11.a	
						X	X		A.11.b	
							X		A.12	

Items in Appendix	<i>A - GENERAL CHARACTERISTICS OF THE SATELLITE NETWORK OR SYSTEM, EARTH STATION OR RADIO ASTRONOMY STATION</i>
<b>A.13</b>	<b>REFERENCES TO THE PUBLISHED SPECIAL SECTIONS OF THE BUREAU'S INTERNATIONAL FREQUENCY INFORMATION CIRCULAR (see the Preface)</b>
A.13.a	the reference and number of the advance publication information in accordance with No. 9.1 or No. 9.1A
A.13.b	the reference and number of the coordination request in accordance with No. 9.6 For the notification of an earth station, the reference to the Special Section of the associated satellite network or system has to be provided For the notification of an earth station coordinated under No. 9.7A, the coordination Special Section number of this earth station has to be provided
A.13.c	the reference and number of the information in accordance with Article 4 of Appendix 30
A.13.d	the reference and number of the information in accordance with Article 4 of Appendix 30A
A.13.e	the reference and number of the information in accordance with Article 6 of Appendix 30B
<b>A.14</b>	<b>FOR STATIONS OPERATING IN A FREQUENCY BAND SUBJECT TO Nos. 22.5C, 22.5D, 22.5F OR 22.5L: SPECTRUM MASKS</b>
A.14.a	<b>For each e.i.r.p. mask used by the non-geostationary space station:</b>
A.14.a.1	the mask identification code
A.14.a.2	the lowest frequency for which the mask is valid
A.14.a.3	the highest frequency for which the mask is valid
A.14.a.4	the mask pattern defined in terms of the power in the reference bandwidth for a series of angles measured at the non-geostationary space station between the line to the sub-satellite point and the line to a point on the geostationary arc, together with the bandwidth used
A.14.a.5	the reference bandwidth used for the mask pattern of A.14.a.4
A.14.b	<b>For each associated earth station e.i.r.p. mask:</b>
A.14.b.1	the mask identification code
A.14.b.2	the lowest frequency for which the mask is valid
A.14.b.3	the highest frequency for which the mask is valid
A.14.b.4	<b>Not used</b>
A.14.b.5	<b>Not used</b>
A.14.b.6	the mask pattern defined in terms of the power in the reference bandwidth as a function of latitude and the off-axis angle between the non-geostationary earth station boresight line and the line from the non-geostationary earth station to a point on the GSO arc
A.14.b.7	the reference bandwidth used for the mask pattern of A.14.b.6
A.14.c	<b>For each pfd mask used by the non-geostationary space station:</b> <i>Note</i> – The space station pfd mask is defined by the maximum power flux-density generated by any space station in the interfering non-geostationary-satellite system as seen from any point on the surface of the Earth

Advance publication of a geostationary-satellite network	Advance publication of a non-geostationary-satellite network or system subject to coordination under Section II of Article 9	Advance publication of a non-geostationary-satellite network or system not subject to coordination under Section II of Article 9	Notification or coordination of a geostationary-satellite network (including space operation functions under Article 2A of Appendices 30 or 30A)	Notification or coordination of a non-geostationary-satellite network or system	Notification or coordination of an earth station (including notification under Appendices 30A or 30B)	Notice for a satellite network in the broadcasting-satellite service under Appendix 30 (Articles 4 and 5)	Notice for a satellite network (feeder-link) under Appendix 30A (Articles 4 and 5)	Notice for a satellite network in the fixed-satellite service under Appendix 30B (Articles 6 and 8)	Items in Appendix	Radio astronomy
									A.13	
			X	X	X				A.13.a	
			X	X	X				A.13.b	
						X			A.13.c	
					X		X		A.13.d	
					X			X	A.13.e	
									A.14	
									A.14.a	
				X					A.14.a.1	
				X					A.14.a.2	
				X					A.14.a.3	
				X					A.14.a.4	
				X					A.14.a.5	
									A.14.b	
				X					A.14.b.1	
				X					A.14.b.2	
				X					A.14.b.3	
									A.14.b.4	
									A.14.b.5	
				X					A.14.b.6	
				X					A.14.b.7	
									A.14.c	

Items in Appendix	<b>A - GENERAL CHARACTERISTICS OF THE SATELLITE NETWORK OR SYSTEM, EARTH STATION OR RADIO ASTRONOMY STATION</b>
A.14.c.1	the mask identification code
A.14.c.2	the lowest frequency for which the mask is valid
A.14.c.3	the highest frequency for which the mask is valid
A.14.c.4	the type of mask, among one of the following types: (Earth-based exclusion zone angle, difference in longitude, latitude), (satellite-based exclusion zone angle, difference in longitude, latitude) or (satellite azimuth, satellite elevation, latitude)
A.14.c.5	the mask pattern of the power flux-density defined in three dimensions
A.14.c.6	the reference bandwidth used for the mask pattern of A.14.c.5
A.14.d	<b>For each set of non-geostationary-satellite system operating parameters</b> to be provided, if A.4.b.6bis indicates the use of an extended set of operating parameters <i>Note</i> – There could be different sets of parameters at different frequency bands, but only one set of operating parameters for any frequency band used by the non-geostationary-satellite system
A.14.d.1	the parameter set identification code
A.14.d.2	the lowest frequency for which the mask is valid
A.14.d.3	the highest frequency for which the mask is valid
A.14.d.4	minimum limit of the latitude range of non-geostationary earth station locations in degrees North
A.14.d.5	maximum limit of the latitude range of non-geostationary earth station locations in degrees North
A.14.d.6	the average number of associated earth stations, per km <sup>2</sup> , active at the same time
A.14.d.7	the average distance, in kilometres, between co-frequency cell or beam footprint centre
A.14.d.8	the minimum duration, in seconds, during which an earth station will track a non-geostationary satellite without handover for different ranges of latitude
A.14.d.9	the maximum number of co-frequency tracked non-geostationary satellites for different ranges of latitude
A.14.d.10	the exclusion zone angle (degrees), i.e. the minimum angle to the geostationary arc at the non-geostationary earth station at which it will operate, defined at the earth station's given latitude range <i>Note</i> – The exclusion zone angle could vary between non-geostationary-satellite system orbit planes. If the identification code of the orbital plane is not defined then it applies to all orbital planes
A.14.d.11	the minimum elevation angle (degrees) of the non-geostationary earth station when it is receiving or transmitting within a given latitude (degrees North) and azimuth (degrees from North) range

Advance publication of a geostationary-satellite network	Advance publication of a non-geostationary-satellite network or system subject to coordination under Section II of Article 9	Advance publication of a non-geostationary-satellite network or system not subject to coordination under Section II of Article 9	Notification or coordination of a geostationary-satellite network (including space operation functions under Article 2A of Appendices 30 or 30A)	Notification or coordination of a non-geostationary-satellite network or system	Notification or coordination of an earth station (including notification under Appendices 30A or 30B)	Notice for a satellite network in the broadcasting-satellite service under Appendix 30 (Articles 4 and 5)	Notice for a satellite network (feeder-link) under Appendix 30A (Articles 4 and 5)	Notice for a satellite network in the fixed-satellite service under Appendix 30B (Articles 6 and 8)	Items in Appendix	Radio astronomy
				X				A.14.c.1		
				X				A.14.c.2		
				X				A.14.c.3		
				X				A.14.c.4		
				X				A.14.c.5		
				X				A.14.c.6		
								A.14.d		
				+				A.14.d.1		
				+				A.14.d.2		
				+				A.14.d.3		
				+				A.14.d.4		
				+				A.14.d.5		
				+				A.14.d.6		
				+				A.14.d.7		
				+				A.14.d.8		
				+				A.14.d.9		
				+				A.14.d.10		
				+				A.14.d.11		

Items in Appendix	<i>A - GENERAL CHARACTERISTICS OF THE SATELLITE NETWORK OR SYSTEM, EARTH STATION OR RADIO ASTRONOMY STATION</i>
<b>A.15</b>	<b>COMMITMENT REGARDING COMPLIANCE WITH ADDITIONAL OPERATIONAL EQUIVALENT POWER FLUX-DENSITY, <math>epfd_{\downarrow}</math>, LIMITS</b>
A.15.a	a commitment that the filed for system will meet the additional operational $epfd_{\downarrow}$ limits that are specified in Table 22-4A1 under No. 22.51 Required only for non-geostationary-satellite systems operating in the fixed-satellite service in the frequency bands 10.7-11.7 GHz (in all Regions), 11.7-12.2 GHz (Region 2), 12.2-12.5 GHz (Region 3), and 12.5-12.75 GHz (Regions 1 and 3)
<b>A.16</b>	<b>COMMITMENT REGARDING COMPLIANCE WITH OFF-AXIS POWER LIMITATIONS, POWER FLUX-DENSITY (pfd) LIMITS OR SEPARATION DISTANCE</b>
A.16.a	a commitment that the associated earth stations operating with a geostationary-satellite network in the fixed-satellite service meet the off-axis power limitations given in Nos. 22.26 to 22.28 or 22.32 (as appropriate) under the conditions specified in Nos. 22.30, 22.31 and 22.34 to 22.39 Required only for earth stations that are subject to those power limitations
A.16.b	a commitment by administrations that the filed system will meet the single entry power flux-density limits that are specified in No. 5.502 Required only for specific earth station antennas less than 4.5 m in diameter operating with geostationary space stations in the fixed-satellite service in the frequency band 13.75-14 GHz
A.16.c	a commitment by administrations that the earth station associated with the filed system will meet the separation distance as specified in No. 5.509E and the power flux-density limits that are specified in No. 5.509D Required only for earth stations of geostationary-satellite networks operating in the fixed-satellite service in the frequency band 14.5-14.8 GHz except feeder links for the broadcasting-satellite service
<b>A.17</b>	<b>COMPLIANCE WITH POWER FLUX-DENSITY (pfd) LIMITS</b>
A.17.a	a commitment of compliance with per-satellite power flux-density level produced at the Earth's surface of $-129 \text{ dB(W/(m}^2 \cdot \text{MHz))}$ in any 1 MHz band under free space propagation conditions Required only for satellite systems operating in the radionavigation-satellite service in the frequency band 1 164-1 215 MHz
A.17.abis	the equivalent power flux-density ( $epfd$ ) produced at the site of a radio astronomy station in the frequency band 1 610.6-1 613.8 MHz, as defined in No. 5.372 Required only for non-geostationary-satellite systems operating in the mobile-satellite service (space-to-Earth) in the frequency band 1 613.8-1 626.5 MHz
A.17.b.1	the calculated aggregate power flux-density produced at the Earth's surface by any geostationary radionavigation-satellite system in the frequency band 4 990-5 000 MHz in a 10 MHz bandwidth, as defined in <i>resolves 1</i> of Resolution 741 (Rev.WRC-15) Required only for geostationary-satellite systems operating in the radionavigation-satellite service in the frequency band 5 010-5 030 MHz





Items in Appendix	<p><b>A - GENERAL CHARACTERISTICS OF THE SATELLITE NETWORK OR SYSTEM, EARTH STATION OR RADIO ASTRONOMY STATION</b></p>
A.17.b.2	<p>the calculated aggregate power flux-density produced at the Earth's surface by all space stations within any radionavigation-satellite service system in the frequency band 5 030-5 150 MHz in a 150 kHz bandwidth, as defined in No. <b>5.443B</b></p> <p>Required only for satellite systems operating in the radionavigation-satellite service in the frequency band 5 010-5 030 MHz</p>
A.17.b.3	<p>the equivalent power flux-density produced at the Earth's surface by all space stations within any non-geostationary radionavigation-satellite service system in the frequency band 4 990-5 000 MHz in a 10 MHz bandwidth, as defined in <i>resolves</i> 2 of Resolution <b>741 (Rev.WRC-15)</b></p> <p>Required only for non-geostationary-satellite systems operating in the radionavigation-satellite service in the frequency band 5 010-5 030 MHz</p>
A.17.c	<b>Not used</b>
A.17.d	<p>the mean power flux-density produced at the Earth's surface by any spaceborne sensor, as defined in No. <b>5.549A</b> for the frequency band 35.5-36 GHz or in Table <b>21-4</b> for the frequency band 9 900-10 400 MHz</p> <p>Required only for satellite systems operating in</p> <ul style="list-style-type: none"> <li>• the Earth exploration-satellite service (active) or space research service (active) in the frequency band 35.5-36 GHz</li> <li>• the Earth exploration-satellite service (active) in the frequency band 9 900-10 400 MHz</li> </ul>
A.17.e.1	<p>the calculated equivalent power flux-density produced at the site of a radio astronomy station in the frequency band 42.5-43.5 GHz, as defined in No. <b>5.551H</b></p> <p>Required only for non-geostationary-satellite systems operating in the fixed-satellite service and broadcasting-satellite service in the frequency band 42-42.5 GHz</p>
A.17.e.2	<p>the calculated power flux-density produced at the site of a radio astronomy station in the frequency band 42.5-43.5 GHz, as defined in No. <b>5.551I</b></p> <p>Required only for geostationary-satellite systems operating in the fixed-satellite service and broadcasting-satellite service in the frequency band 42-42.5 GHz</p>
<b>A.18</b>	<b>COMPLIANCE WITH NOTIFICATION OF AIRCRAFT EARTH STATION(S)</b>
A.18.a	<p>a commitment that the characteristics of the aircraft earth station (AES) in the aeronautical mobile-satellite service are within the characteristics of the specific and/or typical earth station published by the Bureau for the space station to which the AES is associated</p> <p>Required only for the frequency band 14-14.5 GHz, when an aircraft earth station in the aeronautical mobile-satellite service communicates with a space station in the fixed-satellite service</p>
<b>A.19</b>	<b>COMPLIANCE WITH § 6.26 OF ARTICLE 6 OF APPENDIX 30B OR WITH OTHER PROVISIONS REFERENCED BY ARTICLE 5</b>
A.19.a	<p>a commitment that the use of the assignment shall not cause unacceptable interference to, nor claim protection from, those assignments for which agreement still needs to be obtained</p> <p>Required only if the notice is submitted under § 6.25 of Article 6 of Appendix <b>30B</b></p>

	Advance publication of a geostationary-satellite network											
	Advance publication of a non-geostationary-satellite network or system subject to coordination under Section II of Article 9											
	Advance publication of a non-geostationary-satellite network or system not subject to coordination under Section II of Article 9											
	Notification or coordination of a geostationary-satellite network (including space operation functions under Article 2A of Appendices 30 or 30A)			+								
	Notification or coordination of a non-geostationary-satellite network or system					+						
	Notification or coordination of an earth station (including notification under Appendices 30A or 30B)											
	Notice for a satellite network in the broadcasting-satellite service under Appendix 30 (Articles 4 and 5)											
	Notice for a satellite network (feeder-link) under Appendix 30A (Articles 4 and 5)											
	Notice for a satellite network in the fixed-satellite service under Appendix 30B (Articles 6 and 8)											
												Items in Appendix
											A.17.b.2	
											A.17.b.3	
											A.17.c	
											A.17.d	
				+								
						+						
											A.17.e.1	
				+								
											A.17.e.2	
											<b>A.18</b>	
				+								
											A.18.a	
											<b>A.19</b>	
										+		
											A.19.a	
												Radio astronomy

Items in Appendix	<p><b>A - GENERAL CHARACTERISTICS OF THE SATELLITE NETWORK OR SYSTEM, EARTH STATION OR RADIO ASTRONOMY STATION</b></p>
A.19.b	<p>a commitment in accordance with <i>resolves</i> 1.5 of Resolution <b>156 (WRC-15)</b> that the administration responsible for the use of the assignment shall implement <i>resolves</i> 1.4 of Resolution <b>156 (WRC-15)</b></p> <p>Required only for geostationary-satellite networks operating in the fixed-satellite service in the frequency bands 19.7-20.2 GHz and 29.5-30.0 GHz communicating with transmitting earth stations in motion</p>
<b>A.20</b>	<b>COMPLIANCE WITH <i>resolves</i> 1.1.4 OF RESOLUTION 169 (WRC-19)</b>
A.20.a	<p>a commitment that the ESIM operation would be in conformity with the Radio Regulations and Resolution <b>169 (WRC-19)</b></p> <p>Required only for the notification of earth stations in motion submitted in accordance with Resolution <b>169 (WRC-19)</b></p>
<b>A.21</b>	<b>COMPLIANCE WITH <i>resolves</i> 1.2.6 OF RESOLUTION 169 (WRC-19)</b>
A.21.a	<p>a commitment that, upon receiving a report of unacceptable interference, the notifying administration for the GSO FSS network with which ESIMs communicate shall follow the procedures in <i>resolves</i> 4 of Resolution <b>169 (WRC-19)</b></p> <p>Required only for the notification of earth stations in motion submitted in accordance with Resolution <b>169 (WRC-19)</b></p>
<b>A.22</b>	<b>COMPLIANCE WITH <i>resolves</i> 7 OF RESOLUTION 169 (WRC-19)</b>
A.22.a	<p>a commitment that aeronautical ESIMs would be in conformity with the pfd limits on the Earth's surface specified in Part II of Annex 3 to Resolution <b>169 (WRC-19)</b></p> <p>Required only for the notification of earth stations in motion submitted in accordance with Resolution <b>169 (WRC-19)</b></p>
<b>A.23</b>	<b>COMPLIANCE WITH RESOLUTION 35 (WRC-19)</b>
A.23.a	<p>a commitment stating that the characteristics as modified will not cause more interference or require more protection than the characteristics provided in the latest notification information published in Part I-S of the BR IFIC for the frequency assignments to the non-geostationary-satellite system</p>
<b>A.24</b>	<b>COMPLIANCE WITH NOTIFICATION OF A NON-GSO SHORT DURATION MISSION</b>
A.24.a	<p>a commitment by the administration that, in the case that unacceptable interference caused by a non-GSO satellite network or system identified as short-duration mission in accordance with Resolution <b>32 (WRC-19)</b> is not resolved, the administration shall undertake steps to eliminate the interference or reduce it to an acceptable level</p> <p>Required only for notification</p>



**TABLE B**  
**CHARACTERISTICS TO BE PROVIDED FOR EACH SATELLITE ANTENNA BEAM OR**  
**EACH EARTH STATION OR RADIO ASTRONOMY ANTENNA** (Rev.WRC-19)

Items in Appendix	<p><i>B - CHARACTERISTICS TO BE PROVIDED FOR EACH SATELLITE ANTENNA BEAM OR EACH EARTH STATION OR RADIO ASTRONOMY ANTENNA</i></p>
<b>B.1</b>	<b>IDENTIFICATION AND DIRECTION OF THE SATELLITE ANTENNA BEAM</b>
B.1.a	the designation of the satellite antenna beam For an earth station, the designation of the satellite antenna beam of the associated space station
B.1.b	an indicator showing whether the antenna beam, under B.1.a, is fixed or whether it is steerable and / or reconfigurable
B.1.c	if the beam is part of a multiple-beam network, the multiple beam identification code
<b>B.1.d</b>	<b>For sensor operation</b>
B.1.d.1	an indicator showing whether the beam is for an active or passive sensor
<b>B.2</b>	<b>TRANSMISSION / RECEPTION INDICATOR FOR THE BEAM OF THE SPACE STATION OR THE ASSOCIATED SPACE STATION</b>
<b>B.2bis</b>	<b>Not used</b>
B.2bis.a	<b>Not used</b>
B.2bis.b	<b>Not used</b>
<b>B.2.a</b>	<b>For the space station transmitting beam, continuous/non-continuous transmission indicators</b>
B.2.a.1	an indicator specifying whether the space station only transmits when visible from the notified service area In the case of non-geostationary-satellite systems, required only for frequency assignments not subject to Nos. <b>22.5C</b> , <b>22.5D</b> , <b>22.5F</b> or <b>22.5L</b>
B.2.a.2	if the non-geostationary-satellite beam's transmissions are non-continuous, the minimum elevation angle above which transmissions occur when the space station is visible from the notified service area Not required for coordination and notification of frequency assignments subject to Nos. <b>22.5C</b> , <b>22.5D</b> , <b>22.5F</b> or <b>22.5L</b>
<b>B.3</b>	<b>SPACE STATION ANTENNA CHARACTERISTICS</b>
B.3.a	<b>For each space station antenna:</b>
B.3.a.1	the maximum co-polar isotropic gain, in dBi Where a steerable beam (see No. <b>1.191</b> ) is used, if the effective boresight area (see No. <b>1.175</b> ) is identical with the global service area, the maximum antenna gain, in dBi, is applicable to all points on the Earth's visible surface
B.3.a.2	if a non-elliptical beam, the maximum cross-polar isotropic antenna gain, in dBi

Advance publication of a geostationary-satellite network	Advance publication of a non-geostationary-satellite network or system subject to coordination under Section II of Article 9	Advance publication of a non-geostationary-satellite network or system not subject to coordination under Section II of Article 9	Notification or coordination of a geostationary-satellite network (including space operation functions under Article 2A of Appendices 30 or 30A)	Notification or coordination of a non-geostationary-satellite network or system	Notification or coordination of an earth station (including notification under Appendices 30A or 30B)	Notice for a satellite network in the broadcasting-satellite service under Appendix 30 (Articles 4 and 5)	Notice for a satellite network (feeder-link) under Appendix 30A (Articles 4 and 5)	Notice for a satellite network in the fixed-satellite service under Appendix 30B (Articles 6 and 8)	Items in Appendix	Radio astronomy
		X	X	X	X	X	X	X	<b>B.1</b>	
		X	X	X		X	X	X	B.1.a	
		X	X	X				X	B.1.b	
								+	B.1.c	
		X	X	X					<b>B.1.d</b>	
		X	X	X					B.1.d.1	
		X	X	X	+1			X	<b>B.2</b>	
									<b>B.2bis</b>	
									B.2bis.a	
									B.2bis.b	
		X			+				<b>B.2.a</b>	
									B.2.a.1	
		O			O				B.2.a.2	
									<b>B.3</b>	
									B.3.a	
		X	X	X		X	X	X	B.3.a.1	
						+	+		B.3.a.2	

Items in Appendix	<b>B - CHARACTERISTICS TO BE PROVIDED FOR EACH SATELLITE ANTENNA BEAM OR EACH EARTH STATION OR RADIO ASTRONOMY ANTENNA</b>
B.3.b	<b>Antenna gain contours:</b>
B.3.b.1	<p>the co-polar antenna gain contours plotted on a map of the Earth's surface, preferably in a radial projection from the satellite onto a plane perpendicular to the axis from the centre of the Earth to the satellite</p> <p>The space station antenna gain contours shall be drawn as isolines of the isotropic gain, at least for -2, -4, -6, -10 and -20 dB and at 10 dB intervals thereafter, as necessary, relative to the maximum antenna gain, when any of these contours is located either totally or partially anywhere within the limit of visibility of the Earth from the given geostationary satellite</p> <p>Whenever possible, the gain contours of the space station antenna should also be provided in a numerical format (e.g. equation or table)</p> <p>Where a steerable beam (see No. 1.191) is used, if the effective boresight area (see No. 1.175) is less than the global service area, the contours are the result of moving the boresight of the steerable beam around the limit defined by the effective boresight area and are to be provided as described above but shall also include the 0 dB relative gain isoline. In addition, for a steerable transmitting beam, except for the case of Appendix 30B, see also No. 21.16 (and its associated Rules of Procedure)</p> <p>The antenna gain contours shall include the effects of the planned inclination excursion, longitudinal tolerance and the planned pointing accuracy of the antenna</p> <p><i>Note</i> – Taking due account of applicable technical restrictions and allowing some reasonable degree of flexibility for satellite operations, administrations should, to the extent practicable, align the areas the satellite steerable beams could cover with the service area of their networks or systems with due regard to their service objectives.</p> <p style="text-align: center;">In the case of Appendix 30, 30A or 30B, required only for non-elliptical beams</p>
B.3.b.2	if a non-elliptical beam, the cross-polar gain contours shall be provided as defined under B.3.b.1
B.3.c	<b>Antenna radiation patterns:</b>
B.3.c.1	<p>the co-polar antenna radiation pattern</p> <p>In the case of geostationary space stations required only for an antenna radiation beam that is directed towards another satellite</p> <p>In the case of Appendix 30, 30A or 30B, required only for elliptical antenna beams</p>
B.3.c.2	if an elliptical beam, the cross-polar antenna radiation pattern
B.3.d	<p>the pointing accuracy of the antenna</p> <p>In the case of Appendix 30, 30A or 30B, required only for elliptical beams</p>
B.3.e	<p>if the space station is operating in a frequency band allocated in the Earth-to-space direction and in the space-to-Earth direction, the gain of the antenna in the direction of those parts of the geostationary-satellite orbit which are not obstructed by the Earth.</p> <p>In the case of Appendix 30, required only for the frequency band 12.5-12.7 GHz</p>
B.3.f	<b>For a space station submitted in accordance with Appendix 30, 30A or 30B:</b>
B.3.f.1	the boresight or aim point of the antenna beam (longitude and latitude)
B.3.f.2	<b>For each elliptical beam:</b>
B.3.f.2.a	the rotational accuracy, in degrees
B.3.f.2.b	the major axis orientation, in degrees, anticlockwise from the Equator
B.3.f.2.c	the major axis, in degrees, at the half-power beamwidth
B.3.f.2.d	the minor axis, in degrees, at the half-power beamwidth

Advance publication of a geostationary-satellite network	Advance publication of a non-geostationary-satellite network or system subject to coordination under Section II of Article 9	Advance publication of a non-geostationary-satellite network or system not subject to coordination under Section II of Article 9	Notification or coordination of a geostationary-satellite network (including space operation functions under Article 2A of Appendices 30 or 30A)	Notification or coordination of a non-geostationary-satellite network or system	Notification or coordination of an earth station (including notification under Appendices 30A or 30B)	Notice for a satellite network in the broadcasting-satellite service under Appendix 30 (Articles 4 and 5)	Notice for a satellite network (feeder-link) under Appendix 30A (Articles 4 and 5)	Notice for a satellite network in the fixed-satellite service under Appendix 30B (Articles 6 and 8)	Items in Appendix	Radio astronomy
			X						B.3.b B.3.b.1	
						+	+		B.3.b.2	
									B.3.c	
		X	+	X		+	+	+	B.3.c.1	
						+	+		B.3.c.2	
			X			+	+	+	B.3.d	
			+			+	+		B.3.e	
									B.3.f	
						X	X	X	B.3.f.1	
									B.3.f.2	
						X	X	X	B.3.f.2.a	
						X	X	X	B.3.f.2.b	
						X	X	X	B.3.f.2.c	
						X	X	X	B.3.f.2.d	



Items in Appendix	<b>B - CHARACTERISTICS TO BE PROVIDED FOR EACH SATELLITE ANTENNA BEAM OR EACH EARTH STATION OR RADIO ASTRONOMY ANTENNA</b>
<b>B.4</b>	<b>ADDITIONAL CHARACTERISTICS FOR NON-GEOSTATIONARY SPACE STATION ANTENNA</b>
B.4.a.1	the reference number of each orbital plane in which the space station antenna characteristics are used
B.4.a.2	if the antenna characteristics of a space station are not common to every satellite in the specified orbital plane, the reference number of each satellite in the specified orbital plane, on which the space station antenna characteristics are used
B.4.a.3	<b>For a space station submitted in accordance with Nos. 9.11A, 9.12, 9.12A or for active or passive sensors on board a non-geostationary-satellite network or system not subject to coordination under Section II of Article 9:</b>
B.4.a.3.a	<b>For the orientation angles of the satellite transmitting and receiving antenna beams:</b>
B.4.a.3.a.1	the orientation angle alpha, in degrees (see the most recent version of Recommendation ITU-R SM.1413)
B.4.a.3.a.2	the orientation angle beta, in degrees (see the most recent version of Recommendation ITU-R SM.1413)
B.4.b	<b>For a space station submitted in accordance with Nos. 9.11A, 9.12 or 9.12A:</b>
B.4.b.1	<b>Not used</b>
B.4.b.1.a	<b>Not used</b>
B.4.b.1.b	<b>Not used</b>
B.4.b.2	the satellite antenna gain $G(\theta_e)$ as a function of elevation angle ( $\theta_e$ ) at a fixed point on the Earth
B.4.b.3	<b>Not used</b>
B.4.b.4	<b>For each transmitting beam:</b>
B.4.b.4.a	the maximum beam peak e.i.r.p./4 kHz
B.4.b.4.b	the average beam peak e.i.r.p./4 kHz
B.4.b.4.c	the maximum beam peak e.i.r.p./1 MHz
B.4.b.4.d	the average beam peak e.i.r.p./1 MHz
B.4.b.5	the calculated peak value of power flux-density produced within $\pm 5^\circ$ inclination of the geostationary-satellite orbit Required only for the fixed-satellite service (space-to-Earth) in the frequency band 6 700-7 075 MHz
<b>B.5</b>	<b>EARTH STATION ANTENNA CHARACTERISTICS</b>
B.5.a	the isotropic gain, in dBi, of the antenna in the direction of maximum radiation (see No. <b>1.160</b> )
B.5.b	the half-power beamwidth, in degrees
B.5.c	either the measured radiation pattern of the antenna or the reference radiation pattern to be used for coordination For coordination under No. <b>9.7A</b> , the reference radiation pattern is to be provided
B.5.d	antenna dimension aligned with the geostationary arc ( $D_{GS0}$ ), in metres (see the most recent version of Recommendation ITU-R S.1855) Except for Appendix <b>30</b> or <b>30A</b>
<b>B.6</b>	<b>RADIO ASTRONOMY STATION ANTENNA CHARACTERISTICS</b>
B.6.a	the antenna type (see the Preface)
B.6.b	the antenna dimensions (see the Preface)
B.6.c	the effective area of the antenna (see the Preface)

Advance publication of a geostationary-satellite network	Advance publication of a non-geostationary-satellite network or system subject to coordination under Section II of Article 9	Advance publication of a non-geostationary-satellite network or system not subject to coordination under Section II of Article 9	Notification or coordination of a geostationary-satellite network (including space operation functions under Article 2A of Appendices 30 or 30A)	Notification or coordination of a non-geostationary-satellite network or system	Notification or coordination of an earth station (including notification under Appendices 30A or 30B)	Notice for a satellite network in the broadcasting-satellite service under Appendix 30 (Articles 4 and 5)	Notice for a satellite network (feeder-link) under Appendix 30A (Articles 4 and 5)	Notice for a satellite network in the fixed-satellite service under Appendix 30B (Articles 6 and 8)	Items in Appendix	Radio astronomy
									<b>B.4</b>	
		X		X					B.4.a.1	
		+		+					B.4.a.2	
									B.4.a.3	
									B.4.a.3.a	
		X		X					B.4.a.3.a.1	
		X		X					B.4.a.3.a.2	
									B.4.b	
									B.4.b.1	
									B.4.b.1.a	
				X					B.4.b.1.b	
									B.4.b.2	
									B.4.b.3	
									B.4.b.4	
				X					B.4.b.4.a	
				X					B.4.b.4.b	
				X					B.4.b.4.c	
				X					B.4.b.4.d	
				+					B.4.b.5	
									<b>B.5</b>	
					X				B.5.a	
					+ 1				B.5.b	
					X				B.5.c	
					O				B.5.d	
									<b>B.6</b>	
									B.6.a	X
									B.6.b	X
									B.6.c	X

**TABLE C**  
**CHARACTERISTICS TO BE PROVIDED FOR EACH GROUP OF FREQUENCY ASSIGNMENTS**  
**FOR A SATELLITE ANTENNA BEAM OR AN EARTH STATION OR**  
**RADIO ASTRONOMY ANTENNA** (Rev.WRC-19)

Items in Appendix	<p><i>C - CHARACTERISTICS TO BE PROVIDED FOR EACH GROUP OF FREQUENCY ASSIGNMENTS FOR A SATELLITE ANTENNA BEAM OR AN EARTH STATION OR RADIO ASTRONOMY ANTENNA</i></p>
<b>C.1</b>	<b>FREQUENCY RANGE</b>
C.1.a	the lower limit of the frequency range within which the carriers and the bandwidth of the emission will be located for each Earth-to-space or space-to-Earth service area, or for each space-to-space relay
C.1.b	the upper limit of the frequency range within which the carriers and the bandwidth of the emission will be located for each Earth-to-space or space-to-Earth service area, or for each space-to-space relay
<b>C.2</b>	<b>ASSIGNED FREQUENCY (FREQUENCIES)</b>
C.2.a.1	<p>the assigned frequency (frequencies), as defined in No. <b>1.148</b></p> <ul style="list-style-type: none"> <li>– in kHz up to 28 000 kHz inclusive</li> <li>– in MHz above 28 000 kHz to 10 500 MHz inclusive</li> <li>– in GHz above 10 500 MHz</li> </ul> <p>If the basic characteristics are identical, with the exception of the assigned frequency, a list of frequency assignments may be provided</p> <ul style="list-style-type: none"> <li>In the case of advance publication, required only for active sensors</li> <li>In the case of geostationary and non-geostationary-satellite networks or systems, required for all space applications except passive sensors</li> <li>In the case of Appendix <b>30B</b>, required only for notification under Article <b>8</b></li> </ul>
C.2.a.2	the channel number
C.2.b	<p>the centre of the frequency band observed</p> <ul style="list-style-type: none"> <li>– in kHz up to 28 000 kHz inclusive</li> <li>– in MHz above 28 000 kHz to 10 500 MHz inclusive</li> <li>– in GHz above 10 500 MHz</li> </ul> <p>In the case of satellite networks or systems, required only for passive sensors</p>
C.2.c	if the frequency assignment is to be filed under No. <b>4.4</b> , an indication to that effect
<b>C.3</b>	<b>ASSIGNED FREQUENCY BAND</b>
C.3.a	<p>the bandwidth of the assigned frequency band, in kHz (see No. <b>1.147</b>)</p> <ul style="list-style-type: none"> <li>In the case of advance publication, required only for active sensors</li> <li>In the case of geostationary and non-geostationary-satellite networks or systems, required for all space applications except passive sensors</li> <li>In the case of Appendix <b>30B</b>, required only for notification under Article <b>8</b></li> </ul>
C.3.b	<p>the bandwidth of the frequency band, in kHz, observed by the station</p> <ul style="list-style-type: none"> <li>In the case of satellite networks or systems, required only for passive sensors</li> </ul>

Advance publication of a geostationary-satellite network	Advance publication of a non-geostationary-satellite network or system subject to coordination under Section II of Article 9	Advance publication of a non-geostationary-satellite network or system not subject to coordination under Section II of Article 9	Notification or coordination of a geostationary-satellite network (including space operation functions) under Article 2/A of Appendices 30 or 30A)	Notification or coordination of a non-geostationary-satellite network or system	Notification or coordination of an earth station (including notification under Appendices 30A or 30B)	Notice for a satellite network in the broadcasting-satellite service under Appendix 30 (Articles 4 and 5)	Notice for a satellite network (feeder-link) under Appendix 30A (Articles 4 and 5)	Notice for a satellite network in the fixed-satellite service under Appendix 30B (Articles 6 and 8)	Items in Appendix	Radio astronomy
								C.1		
X	X	X						C.1.a		
X	X	X						C.1.b		
								C.2		
								C.2.a.1		
		+	+	+	X	X	X			
						X	X	C.2.a.2		
								C.2.b	X	
		+	+	+	+			C.2.c	+	
								C.3		
								C.3.a		
		+	+	+	X	X	X			
		+	+	+				C.3.b	X	

Items in Appendix	<p><i>C - CHARACTERISTICS TO BE PROVIDED FOR EACH GROUP OF FREQUENCY ASSIGNMENTS FOR A SATELLITE ANTENNA BEAM OR AN EARTH STATION OR RADIO ASTRONOMY ANTENNA</i></p>
<b>C.4</b>	<b>CLASS OF STATION AND NATURE OF SERVICE</b>
C.4.a	the class of station, using the symbols from the Preface
C.4.b	the nature of service performed, using the symbols from the Preface
<b>C.5</b>	<b>RECEIVING SYSTEM NOISE TEMPERATURE</b>
C.5.a	the lowest total receiving system noise temperature, in kelvins, referred to the output of the receiving antenna of the space station In the case of satellite networks or systems, required for all space applications except for active or passive sensors
C.5.b	the lowest total receiving system noise temperature, in kelvins, referred to the output of the receiving antenna of the earth station under clear-sky conditions This value shall be indicated for the nominal value of the angle of elevation when the associated transmitting station is onboard a geostationary satellite and, in other cases, for the minimum value of the angle of elevation
C.5.c	the overall receiving system noise temperature, in kelvins, referred to the output of the receiving antenna
C.5.d	<b>For active sensors:</b>
C.5.d.1	the system noise temperature at the output of the signal processor
C.5.d.2	the receiver noise bandwidth
<b>C.6</b>	<b>POLARIZATION</b>
C.6.a	the type of polarization (see the Preface) For circular polarization, this includes the sense of polarization (see Nos. <b>1.154</b> and <b>1.155</b> ) In the case of a space station submitted in accordance with Appendix <b>30</b> or <b>30A</b> , see § 3.2 of Annex 5 to Appendix <b>30</b>
C.6.b	if linear polarization is used, the angle, in degrees, measured counter-clockwise in a plane normal to the beam axis from the equatorial plane to the electric vector of the waves as seen from the satellite In the case of a space station submitted in accordance with Appendix <b>30</b> or <b>30A</b> , see § 3.2 of Annex 5 to Appendix <b>30</b>
<b>C.7</b>	<b>NECESSARY BANDWIDTH AND CLASS OF EMISSION</b> <i>(in accordance with Article 2 and Appendix 1)</i> For advance publication of a non-geostationary-satellite network or system not subject to coordination under Section II of Article 9, changes to this information within the limits specified under C.1 shall not affect consideration of notification under Article <b>11</b> Not required for active or passive sensors
C.7.a	the necessary bandwidth and the class of emission: for each carrier In the case of Appendix 30B, required only for notification under Article <b>8</b> (including simultaneous submissions for entry into the List under § 6.17 and notification under § 8.1) <i>Note</i> – For simultaneous submissions, the Bureau will use predefined values for the necessary bandwidth when examining the notice under § 6.17 of Article 6 of Appendix 30B
C.7.b	the carrier frequency or frequencies of the emission(s)

Advance publication of a geostationary-satellite network	Advance publication of a non-geostationary-satellite network or system subject to coordination under Section II of Article 9	Advance publication of a non-geostationary-satellite network or system not subject to coordination under Section II of Article 9	Notification or coordination of a geostationary-satellite network (including space operation functions under Article 2A of Appendices 30 or 30A)	Notification or coordination of a non-geostationary-satellite network or system	Notification or coordination of an earth station (including notification under Appendices 30A or 30B)	Notice for a satellite network in the broadcasting-satellite service under Appendix 30 (Articles 4 and 5)	Notice for a satellite network (feeder-link) under Appendix 30A (Articles 4 and 5)	Notice for a satellite network in the fixed-satellite service under Appendix 30B (Articles 6 and 8)	Items in Appendix	Radio astronomy
									C.4	
		X	X	X	X	X	X	X	C.4.a	X
		X	X	X	X				C.4.b	X
									C.5	
		+	+	+			X	X	C.5.a	
					X				C.5.b	
									C.5.c	X
									C.5.d	
		X	X	X					C.5.d.1	
		X	X	X					C.5.d.2	
									C.6	
		X	X	X	+ <sup>1</sup>	X	X		C.6.a	
		+	+	+	+ <sup>1</sup>	+	+		C.6.b	
									C.7	
		X	X	X	X	X	X	+	C.7.a	
		X	C	C	C				C.7.b	

Items in Appendix	<p><b>C - CHARACTERISTICS TO BE PROVIDED FOR EACH GROUP OF FREQUENCY ASSIGNMENTS FOR A SATELLITE ANTENNA BEAM OR AN EARTH STATION OR RADIO ASTRONOMY ANTENNA</b></p>
<b>C.8</b>	<b>POWER CHARACTERISTICS OF THE TRANSMISSION</b> <i>Not required for passive sensors</i>
C.8.a	<b>For the case where individual carriers can be identified:</b>
C.8.a.1	the maximum value of the peak envelope power, in dBW, supplied to the input of the antenna for each carrier type Required if neither C.8.b.1 nor C.8.b.3.a is provided
C.8.a.2	the maximum power density, in dB(W/Hz), supplied to the input of the antenna for each carrier type <sup>2</sup> In the case of satellite networks or systems, required if neither C.8.b.2 nor C.8.b.3.b is provided In the case of Appendix <b>30B</b> , required only for notification under Article 8, or simultaneous submissions for entry into the List under § 6.17 and notification under § 8.1
C.8.b	<b>For the case where it is not appropriate to identify individual carriers:</b>
C.8.b.1	the total peak envelope power, in dBW, supplied to the input of the antenna For coordination or notification of an Appendix <b>30A</b> earth station the values shall include the maximum range of power control In the case of satellite networks or systems, required if neither C.8.a.1 nor C.8.b.3.a is provided
C.8.b.2	the maximum power density, in dB(W/Hz), supplied to the input of the antenna <sup>2</sup> For coordination or notification of an Appendix <b>30A</b> earth station the values shall include the maximum range of power control In the case of satellite networks or systems, required if neither C.8.a.2 nor C.8.b.3.b is provided In the case of Appendix <b>30B</b> , required only for submission under Article 6
C.8.b.3	<b>For the case of active sensors:</b>
C.8.b.3.a	the mean peak envelope power, in dBW, supplied to the input of the antenna Required if neither C.8.a.1 nor C.8.b.1 is provided
C.8.b.3.b	the mean power density, in dB(W/Hz), supplied to the input of the antenna Required if neither C.8.a.2 nor C.8.b.2 is provided
C.8.c	<b>For all space applications, except active or passive sensors:</b>
C.8.c.1	the minimum value of the peak envelope power, in dBW, supplied to the input of the antenna for each carrier type If not provided, the reason for absence under C.8.c.2
C.8.c.2	if C.8.c.1 is not provided, the reason for absence of the minimum value of the peak envelope power
C.8.c.3	the minimum power density, in dB(W/Hz), supplied to the input of the antenna for each carrier type <sup>2</sup> If not provided, the reason for absence under C.8.c.4
C.8.c.4	if C.8.c.3 is not provided, the reason for absence of the minimum power density

Advance publication of a geostationary-satellite network	Advance publication of a non-geostationary-satellite network or system subject to coordination under Section II of Article 9	Advance publication of a non-geostationary-satellite network or system not subject to coordination under Section II of Article 9	Notification or coordination of a geostationary-satellite network (including space operation functions under Article 2A of Appendices 30 or 30A)	Notification or coordination of a non-geostationary-satellite network or system	Notification or coordination of an earth station (including notification under Appendices 30A or 30B)	Notice for a satellite network in the broadcasting-satellite service under Appendix 30 (Articles 4 and 5)	Notice for a satellite network (feeder-link) under Appendix 30A (Articles 4 and 5)	Notice for a satellite network in the fixed-satellite service under Appendix 30B (Articles 6 and 8)	Items in Appendix	Radio astronomy
									<b>C.8</b>	
									C.8.a	
		+	+	+	C				C.8.a.1	
									C.8.a.2	
		+	+	+	O			+	C.8.b	
									C.8.b.1	
		+	+	+	+ <sup>1</sup>	X	X		C.8.b.2	
		+	+	+	+ <sup>1</sup>	X	X	+	C.8.b.3	
									C.8.b.3.a	
		+	+	+					C.8.b.3.b	
									C.8.c	
		+	+	+	+ <sup>1</sup>				C.8.c.1	
		+	+	+	+ <sup>1</sup>				C.8.c.2	
		+	+	+	+ <sup>1</sup>				C.8.c.3	
		+	+	+	+ <sup>1</sup>				C.8.c.4	



Items in Appendix	<p><i>C - CHARACTERISTICS TO BE PROVIDED FOR EACH GROUP OF FREQUENCY ASSIGNMENTS FOR A SATELLITE ANTENNA BEAM OR AN EARTH STATION OR RADIO ASTRONOMY ANTENNA</i></p>
C.8.d.1	<p>the maximum total peak envelope power, in dBW, supplied to the input of the antenna for each contiguous satellite bandwidth</p> <p>For a satellite transponder, this corresponds to the maximum saturated peak envelope power</p> <p>Required only for a space-to-Earth or space-to-space link</p>
C.8.d.2	<p>if the contiguous satellite bandwidth is different from the bandwidth of the assigned frequency band (C.3.a), each contiguous satellite bandwidth</p> <p>For the maximum saturated peak envelope power of the satellite transponder, this corresponds to the bandwidth of each transponder</p> <p>Required only for a space-to-Earth or space-to-space link</p>
C.8.e.1	<p>for space-to-Earth, Earth-to-space or space-to-space links, for each carrier type, the greater of either the carrier-to-noise ratio, in dB, required to meet the performance objective of the link under clear-sky conditions or the carrier-to-noise ratio, in dB, required to meet the short-term performance objective of the link, inclusive of necessary margins</p> <p>If not provided, the reason for absence under C.8.e.2</p>
C.8.e.2	<p>if C.8.e.1 is not provided, the reason for absence of the carrier-to-noise ratio</p>
C.8.f.1	<p>the space station's nominal equivalent isotropically radiated power(s) (e.i.r.p.) on the beam axis</p> <p>Required only for a space-to-space link</p>
C.8.f.2	<p>the associated space station's nominal equivalent isotropically radiated power(s) (e.i.r.p.) on the beam axis</p> <p>Required only for a space-to-space link</p>
C.8.g.1	<p>the maximum aggregate power, in dBW, of all carriers (per transponder, if applicable) supplied to the input of the transmitting antenna of the earth station or the associated earth station</p> <p>Not required for coordination of a specific earth station under Nos. <b>9.15, 9.17</b> or <b>9.17A</b></p>
C.8.g.2	<p>the aggregate bandwidth of all carriers (per transponder, if applicable) supplied to the input of the transmitting antenna of the earth station or the associated earth station</p> <p>Not required for coordination of a specific earth station under Nos. <b>9.15, 9.17</b> or <b>9.17A</b></p>
C.8.g.3	<p>an indicator showing whether the bandwidth of the transponder corresponds to the aggregate bandwidth of all carriers (per transponder, if applicable) supplied to the input of the transmitting antenna of the earth station or the associated earth station</p> <p>Not required for coordination of a specific earth station under Nos. <b>9.15, 9.17</b> or <b>9.17A</b></p>
C.8.h	<p>the maximum power density per Hz supplied to the input of the antenna, in dB(W/Hz), averaged over the necessary bandwidth</p>
C.8.i	<p>If power control is used, the maximum range of power control, in dB</p>
C.8.j	<p><b>Not used</b></p>

Advance publication of a geostationary-satellite network																
Advance publication of a non-geostationary-satellite network or system subject to coordination under Section II of Article 9																
Advance publication of a non-geostationary-satellite network or system not subject to coordination under Section II of Article 9			O													
Notification or coordination of a geostationary-satellite network (including space operation functions under Article 2A of Appendices 30 or 30A)																
Notification or coordination of a non-geostationary-satellite network or system																
Notification or coordination of an earth station (including notification under Appendices 30A or 30B)																
Notice for a satellite network in the broadcasting-satellite service under Appendix 30 (Articles 4 and 5)																
Notice for a satellite network (feeder-link) under Appendix 30A (Articles 4 and 5)																
Notice for a satellite network in the fixed-satellite service under Appendix 30B (Articles 6 and 8)																
													C.8.d.1			
													C.8.d.2			
													C.8.e.1			
													C.8.e.2			
													C.8.f.1			
													C.8.f.2			
													C.8.g.1			
													C.8.g.2			
													C.8.g.3			
													C.8.h			
										X	X	X	C.8.i			
													C.8.j			

Items in Appendix	<p><b>C - CHARACTERISTICS TO BE PROVIDED FOR EACH GROUP OF FREQUENCY ASSIGNMENTS FOR A SATELLITE ANTENNA BEAM OR AN EARTH STATION OR RADIO ASTRONOMY ANTENNA</b></p>
C.9	<p><b>INFORMATION ON MODULATION CHARACTERISTICS</b>  <i>For all space applications except active or passive sensors</i></p>
C.9.a	<b>For each carrier, according to the nature of the signal modulating the carrier:</b>
C.9.a.1	the type of modulation In the case of a non-geostationary space station required only for Nos. 9.11A, 9.12 or 9.12A
C.9.a.2	<b>For a carrier frequency modulated by a frequency-division multichannel telephony baseband (FDM/FM) or by a signal that can be represented by a multichannel telephony baseband:</b>
C.9.a.2.a	the lowest frequency of the baseband
C.9.a.2.b	the highest frequency of the baseband
C.9.a.2.c	the r.m.s. frequency deviation of the pre-emphasized signal for a test tone as a function of baseband frequency
C.9.a.3	<b>For a carrier frequency modulated by a television signal:</b>
C.9.a.3.a	the peak-to-peak frequency deviation of the pre-emphasized signal
C.9.a.3.b	the pre-emphasis characteristic
C.9.a.3.c	if applicable, the characteristics of the multiplexing of the video signal with the sound signal(s) or other signals
C.9.a.4	<b>For a carrier phase-shift modulated by a digital signal:</b>
C.9.a.4.a	the bit rate
C.9.a.4.b	the number of phases
C.9.a.5	<b>For an amplitude modulated carrier (including single sideband):</b>
C.9.a.5.a	the nature of the modulating signal, as precisely as possible
C.9.a.5.b	the kind of amplitude modulation used
C.9.a.6	<b>For a frequency modulated carrier:</b>
C.9.a.6.a	the peak-to-peak frequency deviation, in MHz, of the energy dispersal waveform
C.9.a.6.b	the sweep frequency, in kHz, of the energy dispersal waveform
C.9.a.6.c	the energy dispersal waveform
C.9.a.7	if other forms of modulation than frequency modulation are being used, the type of energy dispersal
C.9.a.8	for all other types of modulation, such particulars as may be useful for an interference study
C.9.a.9	the TV standard
C.9.b	<b>For analogue carriers:</b>
C.9.b.1	the sound-broadcasting characteristics
C.9.b.2	the composition of the baseband

Advance publication of a geostationary-satellite network	Advance publication of a non-geostationary-satellite network or system subject to coordination under Section II of Article 9	Advance publication of a non-geostationary-satellite network or system not subject to coordination under Section II of Article 9	Notification or coordination of a geostationary-satellite network (including space operation functions under Article 2A of Appendices 30 or 30A)	Notification or coordination of a non-geostationary-satellite network or system	Notification or coordination of an earth station (including notification under Appendices 30A or 30B)	Notice for a satellite network in the broadcasting-satellite service under Appendix 30 (Articles 4 and 5)	Notice for a satellite network (feeder-link) under Appendix 30A (Articles 4 and 5)	Notice for a satellite network in the fixed-satellite service under Appendix 30B (Articles 6 and 8)	Items in Appendix	Radio astronomy
									C.9	
		O	C	+		X	X		C.9.a	
									C.9.a.1	
									C.9.a.2	
		O	C	C					C.9.a.2.a	
		O	C	C					C.9.a.2.b	
		O	C	C					C.9.a.2.c	
									C.9.a.3	
		O	C	C		X	X		C.9.a.3.a	
		O	C	C		X	X		C.9.a.3.b	
		O	C	C		+	+		C.9.a.3.c	
									C.9.a.4	
		O	C	C					C.9.a.4.a	
		O	C	C					C.9.a.4.b	
									C.9.a.5	
		O	C	C					C.9.a.5.a	
		O	C	C					C.9.a.5.b	
									C.9.a.6	
		O	C	C		X	X		C.9.a.6.a	
		O	C	C		X	X		C.9.a.6.b	
		O	C	C		X	X		C.9.a.6.c	
		O	C	C		+	+		C.9.a.7	
		O	C	C					C.9.a.8	
		O	C	C		X	X		C.9.a.9	
									C.9.b	
						X	X		C.9.b.1	
						X	X		C.9.b.2	

Items in Appendix	<p><b>C - CHARACTERISTICS TO BE PROVIDED FOR EACH GROUP OF FREQUENCY ASSIGNMENTS FOR A SATELLITE ANTENNA BEAM OR AN EARTH STATION OR RADIO ASTRONOMY ANTENNA</b></p>
C.9.c	<b>For a non-geostationary space station submitted in accordance with Nos. 9.11A, 9.12 or 9.12A:</b>
C.9.c.1	the type of multiple access
C.9.c.2	the spectrum mask
C.9.d	<b>For stations operating in a frequency band subject to Nos. 22.5C, 22.5D, 22.5F or 22.5L:</b>
C.9.d.1	the type of mask
C.9.d.2	the pfd mask identification code
C.9.d.3	the space station's e.i.r.p. mask identification code
C.9.d.4	the associated earth station's e.i.r.p. mask identification code
<b>C.10</b>	<b>TYPE AND IDENTITY OF THE ASSOCIATED STATION(S)</b> <i>(the associated station may be another space station, a typical earth station of the network or system or a specific earth station)</i> <i>For all space applications except active or passive sensors</i>
C.10.a	<b>For an associated space station:</b>
C.10.a.1	the identity of the station
C.10.a.2	if the associated space station is in the geostationary orbit, its nominal longitude
C.10.b	<b>For an associated earth station:</b>
C.10.b.1	the name of the station
C.10.b.2	the type of station (specific or typical)
C.10.c	<b>For a specific associated earth station:</b>
C.10.c.1	the geographical coordinates of the antenna site
C.10.c.2	the country or geographical area in which the earth station is located, using the symbols from the Preface
C.10.d	<b>For an associated earth station (whether specific or typical):</b>
C.10.d.1	the class of station, using the symbols from the Preface
C.10.d.2	the nature of service performed, using the symbols from the Preface
C.10.d.3	the isotropic gain, in dBi, of the antenna in the direction of maximum radiation (see No. 1.160)
C.10.d.4	the beamwidth, in degrees, between the half-power points (described in detail if not symmetrical)
C.10.d.5.a	either the measured co-polar radiation pattern of the antenna or the co-polar reference radiation pattern
C.10.d.5.b	either the measured cross-polar radiation pattern of the antenna or the cross-polar reference radiation pattern
C.10.d.6	if the associated station is a receiving earth station, the lowest total receiving system noise temperature, in kelvins, referred to the output of the receiving antenna of the earth station under clear-sky conditions

Advance publication of a geostationary-satellite network	Advance publication of a non-geostationary-satellite network or system subject to coordination under Section II of Article 9	Advance publication of a non-geostationary-satellite network or system not subject to coordination under Section II of Article 9	Notification or coordination of a geostationary-satellite network (including space operation functions under Article 2A of Appendices 30 or 30A)	Notification or coordination of a non-geostationary-satellite network or system	Notification or coordination of an earth station (including notification under Appendices 30A or 30B)	Notice for a satellite network in the broadcasting-satellite service under Appendix 30 (Articles 4 and 5)	Notice for a satellite network (feeder-link) under Appendix 30A (Articles 4 and 5)	Notice for a satellite network in the fixed-satellite service under Appendix 30B (Articles 6 and 8)	Items in Appendix	Radio astronomy
									C.9.c	
				X					C.9.c.1	
				X					C.9.c.2	
									C.9.d	
				X					C.9.d.1	
				X					C.9.d.2	
				X					C.9.d.3	
				X					C.9.d.4	
									<b>C.10</b>	
									C.10.a	
		X	X	X					C.10.a.1	
		+	+	+					C.10.a.2	
									C.10.b	
		X	X	X			X		C.10.b.1	
		X	X	X					C.10.b.2	
									C.10.c	
		X	X	X			X		C.10.c.1	
		X	X	X			X		C.10.c.2	
									C.10.d	
		X	X	X					C.10.d.1	
		X	X	X					C.10.d.2	
		X	X	X		X	X	X	C.10.d.3	
		O	X	X		X	X	X	C.10.d.4	
		X	X	X		X	X	X	C.10.d.5.a	
						X	X		C.10.d.5.b	
		+	+	+				+	C.10.d.6	

Items in Appendix	<p><b>C - CHARACTERISTICS TO BE PROVIDED FOR EACH GROUP OF FREQUENCY ASSIGNMENTS FOR A SATELLITE ANTENNA BEAM OR AN EARTH STATION OR RADIO ASTRONOMY ANTENNA</b></p>
C.10.d.7	<p>the antenna diameter, in metres</p> <p>In cases other than Appendix <b>30A</b>, required only for fixed-satellite service networks or systems operating in the frequency bands 13.75-14 GHz, 14.5-14.75 GHz (in countries listed in Resolution <b>163 (WRC-15)</b> not for feeder links for the broadcasting-satellite service), 14.5-14.8 GHz (in countries listed in Resolution <b>164 (WRC-15)</b> not for feeder links for the broadcasting-satellite service), 24.65-25.25 GHz (Region 1), 24.65-24.75 GHz (Region 3) and 51.4-52.4 GHz and for maritime mobile-satellite service networks or systems operating in the frequency band 14-14.5 GHz</p>
C.10.d.8	<p>the equivalent antenna diameter (i.e. the diameter, in metres, of a parabolic antenna with the same off-axis performance as the receiving associated earth station antenna)</p>
C.10.d.9	<p>antenna dimension aligned with the geostationary arc (<i>D<sub>GSO</sub></i>), in metres (see the most recent version of Recommendation ITU-R S.1855)</p> <p>Except for Appendix <b>30</b> or <b>30A</b></p>
<b>C.11</b>	<p><b>SERVICE AREA (S)</b></p> <p><i>For all space applications except active or passive sensors</i></p>
C.11.a	<p>the service area or areas of the satellite beam on the Earth, when the associated transmitting or receiving stations are earth stations</p> <p>For a space station submitted in accordance with Appendix <b>30</b>, <b>30A</b> or <b>30B</b>, the service area identified by a set of a maximum of 100 test points and by a service area contour on the surface of the Earth or defined by a minimum elevation angle</p> <p><i>Note</i> – When an assignment converted from an allotment is reinstated in the Appendix <b>30B</b> Plan, the notifying administration may choose a maximum of 20 test points within its national territory for the reinstated allotment</p>
C.11.b	<p>the appropriate information required to calculate the affected region (as defined in Recommendation ITU-R M.1187-1)</p> <p>Required only for a non-geostationary space station in the mobile-satellite service submitted in accordance with No. <b>9.11A</b> in frequency bands between 1 and 3 GHz</p>
<b>C.12</b>	<p><b>REQUIRED PROTECTION RATIO</b></p>
C.12.a	<p>if the aggregate carrier-to-interference ratio is less than 21 dB, the minimum acceptable aggregate carrier-to-interference ratio</p> <p>The carrier-to-interference ratio is to be expressed in terms of the power averaged over the necessary bandwidth of the modulated wanted and interfering signals, assuming both the desired carrier and interfering signals have equivalent bandwidths and modulation types</p>

Advance publication of a geostationary-satellite network									
Advance publication of a non-geostationary-satellite network or system subject to coordination under Section II of Article 9									
Advance publication of a non-geostationary-satellite network or system not subject to coordination under Section II of Article 9									
Notification or coordination of a geostationary-satellite network (including space operation functions under Article 2A of Appendices 30 or 30A)	+								
Notification or coordination of a non-geostationary-satellite network or system	+								
Notification or coordination of an earth station (including notification under Appendices 30A or 30B)									
Notice for a satellite network in the broadcasting-satellite service under Appendix 30 (Articles 4 and 5)						X			
Notice for a satellite network (feeder-link) under Appendix 30A (Articles 4 and 5)							X		
Notice for a satellite network in the fixed-satellite service under Appendix 30B (Articles 6 and 8)								O	
									<b>C.11</b>
				X					C.11.a
				X					
				X					C.11.b
									<b>C.12</b>
									C.12.a
								+	
									Items in Appendix
									Radio astronomy



Items in Appendix	<p><i>C - CHARACTERISTICS TO BE PROVIDED FOR EACH GROUP OF FREQUENCY ASSIGNMENTS FOR A SATELLITE ANTENNA BEAM OR AN EARTH STATION OR RADIO ASTRONOMY ANTENNA</i></p>
<b>C.13</b>	<b>CHARACTERISTICS OF OBSERVATIONS FOR RADIO ASTRONOMY STATIONS</b>
C.13.a	<p>the class of observations to be taken on the frequency band shown under C.3.b</p> <ul style="list-style-type: none"> <li>– Class A observations are those in which the sensitivity of the equipment is not a primary factor</li> <li>– Class B observations are those of such a nature that they can be made only with advanced low-noise receivers using the best techniques</li> </ul>
C.13.b	<p>the type of radio astronomy station in the frequency band shown under C.3.b</p> <ul style="list-style-type: none"> <li>– Single-dish, “S”, telescope used for spectral-line or continuum observations using single-dishes or closely connected arrays</li> <li>– Very long baseline interferometry (VLBI), “V”, station used only for VLBI observations</li> </ul>
C.13.c	<p>the minimum elevation angle <math>\theta_{min}</math> at which the radio astronomy station conducts single-dish or VLBI observations in the frequency band</p>
<b>C.14</b>	<b>Not used</b>
<b>C.15</b>	<b>DESCRIPTION OF THE GROUP(S) REQUIRED IN THE CASE OF NON-SIMULTANEOUS EMISSIONS</b>
C.15.a	<p>if part of an exclusive operation group, the group identification code</p>
<b>C.16</b>	<b>DESCRIPTION OF ACTIVE AND PASSIVE SENSOR SYSTEMS</b>
C.16.a	<b>For active sensors:</b>
C.16.a.1	<p>the pulse length, in <math>\mu</math>s</p>
C.16.a.2	<p>the pulse repetition frequency, in kHz</p>
C.16.b	<b>For passive sensors:</b>
C.16.b.1	<p>the sensitivity threshold, in kelvins</p>

Advance publication of a geostationary-satellite network	Advance publication of a non-geostationary-satellite network or system subject to coordination under Section II of Article 9	Advance publication of a non-geostationary-satellite network or system not subject to coordination under Section II of Article 9	Notification or coordination of a geostationary-satellite network (including space operation functions under Article 2A of Appendices 30 or 30A)	Notification or coordination of a non-geostationary-satellite network or system	Notification or coordination of an earth station (including notification under Appendices 30A or 30B)	Notice for a satellite network in the broadcasting-satellite service under Appendix 30 (Articles 4 and 5)	Notice for a satellite network (feeder-link) under Appendix 30A (Articles 4 and 5)	Notice for a satellite network in the fixed-satellite service under Appendix 30B (Articles 6 and 8)	Items in Appendix	Radio astronomy
									<b>C.13</b>	
									C.13.a	X
									C.13.b	X
									C.13.c	X
									<b>C.14</b>	
									<b>C.15</b>	
						+	+	+	C.15.a	
									<b>C.16</b>	
									C.16.a	
		X	X	X					C.16.a.1	
		X	X	X					C.16.a.2	
									C.16.b	
		X	X	X					C.16.b.1	

**TABLE D**  
**OVERALL LINK CHARACTERISTICS** (Rev.WRC-19)

Items in Appendix	<p><i>D - OVERALL LINK CHARACTERISTICS</i></p>
	<p><i>For non-planned services, this data may be provided by administrations that so desire but only when simple frequency-changing transponders are used on the space station onboard a geostationary satellite</i></p>
<b>D.1</b>	<b>CONNECTION BETWEEN EARTH-TO-SPACE AND SPACE-TO-EARTH FREQUENCIES IN THE NETWORK</b>
D.1.a	<p>the connection between uplink and downlink frequency assignments for each intended combination of receiving and transmitting beams</p> <p>In the case of Appendix 30 or 30A, required only for Region 2</p> <p>In the case of Appendix 30B, required only for submission of both Earth-to-space and space-to-Earth links</p>
<b>D.2</b>	<b>TRANSMISSION GAINS AND ASSOCIATED EQUIVALENT SATELLITE LINK NOISE TEMPERATURES</b>
D.2.a	<b>For each entry under D.1.a:</b>
D.2.a.1	<p>the lowest equivalent satellite link noise temperature</p> <p>These values shall be indicated for the nominal value of the angle of elevation</p>
D.2.a.2	<p>the associated transmission gain of the lowest equivalent satellite link noise temperature</p> <p>These values shall be indicated for the nominal value of the angle of elevation</p> <p>The transmission gain is evaluated from the output of the receiving antenna of the space station to the output of the receiving antenna of the earth station</p>
D.2.b.1	<p>the values of associated equivalent satellite link noise temperature that correspond to the highest ratio of transmission gain to equivalent satellite link noise temperature</p>
D.2.b.2	<p>the values of transmission gain that correspond to the highest ratio of transmission gain to equivalent satellite link noise temperature</p>

Advance publication of a geostationary-satellite network													
Advance publication of a non-geostationary-satellite network or system subject to coordination under Section II of Article 9													
Advance publication of a non-geostationary-satellite network or system not subject to coordination under Section II of Article 9													
Notification or coordination of a geostationary-satellite network (including space operation functions under Article 2A of Appendices 30 or 30A)					O								
Notification or coordination of a non-geostationary-satellite network or system													
Notification or coordination of an earth station (including notification under Appendices 30A or 30B)													
Notice for a satellite network in the broadcasting-satellite service under Appendix 30 (Articles 4 and 5)										+			
Notice for a satellite network (feeder-link) under Appendix 30A (Articles 4 and 5)												+	
Notice for a satellite network in the fixed-satellite service under Appendix 30B (Articles 6 and 8)													+
	<b>D.1</b>												
	D.1.a												
	<b>D.2</b>												
	D.2.a												
	D.2.a.1												
	D.2.a.2												
	D.2.b.1												
	D.2.b.2												
	<b>Radio astronomy</b>												



## APPENDIX 5 (REV.WRC-19)

### Identification of administrations with which coordination is to be effected or agreement sought under the provisions of Article 9

1 For the purpose of effecting coordination under Article 9, except in the case under No. 9.21, and for identifying the administrations with which coordination is to be effected, the frequency assignments to be taken into account are those in the same frequency band as the planned assignment, pertaining to the same service or to another service to which the frequency band is allocated with equal rights or a higher category<sup>1</sup> of allocation, which might affect or be affected, as appropriate, and which are: (WRC-15)

- a) in conformity with No. 11.31<sup>2</sup>; and
- b) either recorded in the Master International Frequency Register (Master Register) with a favourable finding with respect to No. 11.32; or
- c) recorded in the Master Register with an unfavourable finding with respect to No. 11.32 and a favourable finding with respect to No. 11.32A or No. 11.33, as appropriate; or
- cbis*) recorded in the Master Register under No. 11.41; or (WRC-03)
- d) coordinated under the provisions of Article 9; or
- e) included in the coordination procedure with effect from the date of receipt<sup>3</sup> by the Radiocommunication Bureau, in accordance with No. 9.34, of those characteristics specified in Appendix 4 as mandatory or required, or from the date of dispatch, in accordance with No. 9.29, of the appropriate information listed in Appendix 4; or (WRC-15)
- f) where appropriate, in conformity with a world or regional allotment or assignment plan and the associated provisions;
- g) for terrestrial radiocommunication stations or earth stations operating in the opposite direction of transmission<sup>4</sup> and, in addition, operating in accordance with these Regulations, or to be so operated prior to the date of bringing the earth station assignment into service, or within the next three years from the date of dispatch of coordination data under No. 9.29, whichever is the longer, or from the date of the publication referred to in No. 9.38, as appropriate. (WRC-2000)

---

<sup>1</sup> The coordination under Nos. 9.11A to 9.19 applies only to assignments in frequency bands allocated with equal rights. (WRC-15)

<sup>2</sup> For the purpose of effecting coordination, an assignment for which the process of obtaining agreement under No. 9.21 has been initiated is considered to be in conformity with No. 11.31 with respect to No. 9.21.

<sup>3</sup> See No. 9.1A concerning the date to be considered as the date of receipt by the Bureau of the information relating to the coordination of a satellite network or the notification of a frequency assignment. (WRC-15)

<sup>4</sup> The associated space network characteristics must have been communicated to the Bureau under No. 9.30 or under § 4.1.3/4.2.6 of Article 4 of Appendix 30 or § 4.1.3/4.2.6 of Article 4 of Appendix 30A. (WRC-2000)

2 For the application of No. **9.21**, the agreement of an administration may be required with respect to the frequency assignments in the same frequency band as the planned assignment, pertaining to the same service or to another service to which the band is allocated with equal rights or a higher category of allocation, which may affect or be affected, as appropriate, and:

- a) in cases involving a station in a space radiocommunication service with respect to any other station or involving a terrestrial radiocommunication station with respect to an earth station:
  - i) which are in conformity with No. **11.31**, and comply with the relevant conditions listed in § 1 b) to 1 g); or
  - ii) for which the procedure under No. **9.21** has been initiated, with effect from the date of receipt by the Bureau, in accordance with No. **9.34**, of the basic characteristics specified in Appendix 4;

or

- b) for terrestrial radiocommunication stations operating in accordance with these Regulations, or to be so operated prior to the date of bringing the other terrestrial station assignment into service, or within the next three months, whichever is the longer.

3 For each of the frequency assignments to a station of a terrestrial or space radiocommunication service referred to in § 1 and 2 above, the level of interference shall be determined using the method referred to in Table 5-1 which is appropriate to the particular case.

4 The assignment is considered to affect or be affected, as appropriate, and coordination must be sought under the procedure of Article 9, if:

- a) the threshold levels given in Table 5-1 are exceeded; and
- b) the condition specified in Table 5-1 is applicable.

5 Threshold values to determine whether coordination under No. **9.11A** is required are given in Table 5-2.

6 No coordination is required:

- a) when the use of a new frequency assignment will not cause or suffer, as appropriate, in respect of any service of another administration, an increase in the level of interference above the threshold calculated in accordance with the method referred to in Tables 5-1 and 5-2; or
- b) when the characteristics of a new or a modified frequency assignment or a new earth station are within the limits of those of a frequency assignment which has previously been coordinated; or
- c) to change the characteristics of an existing assignment in such a way as not to increase the interference to or from, as appropriate, the assignments of other administrations; or

- d)* for assignments to stations comprising a satellite network in relation to assignments of other satellite networks:
- i)* for a new frequency assignment to a receiving station, when the notifying administration states that it accepts the interference resulting from the frequency assignments referred to in No. **9.27**; or
  - ii)* between earth stations using frequency assignments in the same direction (either Earth-to-space or space-to-Earth); or
- e)* for assignments to earth stations in relation to terrestrial stations or earth stations operating in the opposite direction of transmission, when an administration proposes:
- i)* to bring into use an earth station the coordination area of which does not include any of the territory of any other country;
  - ii)* to operate a mobile earth station. However, if the coordination area associated with the operation of such a mobile earth station includes any of the territory of another country, the operation of such a station shall be subject to agreement on coordination between the administrations concerned. This agreement shall apply to the characteristics of the mobile earth station(s), or to the characteristics of a typical mobile earth station, and shall apply to a specified service area. Unless otherwise stipulated in the agreement, it shall apply to any mobile earth stations in the specified service area provided that interference caused by them shall not be greater than that caused by a typical earth station for which the technical characteristics appear in the notice and have been or are being submitted in accordance with Section I of Article **11**; or
  - iii)* to bring into use a new frequency assignment to a receiving earth station and the notifying administration states that it accepts the interference resulting from existing and future terrestrial station assignments or assignments to earth stations operating in the opposite direction of transmission. In such case, administrations responsible for the terrestrial stations or earth stations operating in the opposite direction of transmission are not required to apply the provisions of No. **9.18** or No. **9.17A** of Article **9** respectively;
- f)* to bring into use an assignment to a terrestrial station or an earth station operating in the opposite direction of transmission which is located, in relation to an earth station, outside the coordination area of that earth station; or
- g)* to bring into use an assignment to a terrestrial station or an earth station operating in the opposite direction of transmission within the coordination area of an earth station, provided that the proposed assignment to a terrestrial station or an earth station operating in the opposite direction of transmission is outside any part of a frequency band coordinated for reception by that earth station.



TABLE 5-1 (Rev.WRC-19)  
**Technical conditions for coordination**  
 (see Article 9)

Reference of Article 9	Case	Frequency bands (and Region) of the service for which coordination is sought	Threshold/condition	Calculation method	Remarks
No. 9.7 GSO/GSO	A station in a satellite network using the geostationary-satellite orbit (GSO), in any space radiocommunication service, in a frequency band and in a Region where this service is not subject to a Plan, in respect of any other satellite network using that orbit, in any space radiocommunication service in a frequency band and in a Region where this service is not subject to a Plan, with the exception of the coordination between earth stations operating in the opposite direction of transmission	1) 3 400-4 200 MHz 5 725-5 850 MHz (Region 1) and 5 850-6 725 MHz 7 025-7 075 MHz  2) 10.95-11.2 GHz 11.45-11.7 GHz 11.7-12.2 GHz (Region 2) 12.2-12.5 GHz (Region 3) 12.5-12.75 GHz (Regions 1 and 3) 12.7-12.75 GHz (Region 2) and 13.75-14.8 GHz	i) Bandwidth overlap, and ii) any network in the fixed-satellite service (FSS) and any associated space operation functions (see No. 1.23) with a space station within an orbital arc of $\pm 7^\circ$ of the nominal orbital position of a proposed network in the FSS  i) Bandwidth overlap, and ii) any network in the FSS or broadcasting-satellite service (BSS), not subject to a Plan, and any associated space operation functions (see No. 1.23) with a space station within an orbital arc of $\pm 6^\circ$ of the nominal orbital position of a proposed network in the FSS or BSS, not subject to a Plan  iii) in the frequency band 14.5-14.8 GHz any network in the space research service (SRS) or FSS not subject to a Plan and any associated space operation functions (see No. 1.23) with a space station within an orbital arc of $\pm 6^\circ$ of the nominal orbital position of a proposed network in the SRS or FSS not subject to a Plan		With respect to the space services listed in the threshold/condition column in the frequency bands in 1), 2), 2 <i>bis</i> ), 3), 3 <i>bis</i> ), 4), 5), 6), 7) and 8), an administration may request, pursuant to No. 9.41, to be included in requests for coordination, indicating the networks for which the value of $\Delta T/T$ calculated by the method in § 2.2.1.2 and 3.2 of Appendix 8 exceeds 6%. When the Bureau, on request by an affected administration studies this information pursuant to No. 9.42, the calculation method given in § 2.2.1.2 and 3.2 of Appendix 8 shall be used

TABLE 5-1 (continued) (Rev. WRC-19)

Reference of Article 9	Case	Frequency bands (and Region) of the service for which coordination is sought	Threshold/condition	Calculation method	Remarks
No. 9.7 GSO/GSO (cont.)		<p>2bis) 13.4-13.65 GHz (Region 1)</p> <p>3) 17.7-19.7 GHz, (Regions 2 and 3), 17.3-19.7 GHz (Region 1) and 27.5-29.5 GHz</p> <p>3bis) 19.7-20.2 GHz and 29.5-30 GHz</p>	<p>i) Bandwidth overlap, and ii) any network in the space research service (SRS) or any network in the FSS and any associated space operation functions (see No. 1.23) with a space station within an orbital arc of <math>\pm 6^\circ</math> of the nominal orbital position of a proposed network in the FSS or SRS</p> <p>i) Bandwidth overlap, and ii) any network in the FSS and any associated space operation functions (see No. 1.23) with a space station within an orbital arc of <math>\pm 8^\circ</math> of the nominal orbital position of a proposed network in the FSS</p> <p>i) Bandwidth overlap, and ii) any network in the FSS or in the mobile-satellite service (MSS) and any associated space operation functions (see No. 1.23) with a space station within an orbital arc of <math>\pm 8^\circ</math> of the nominal orbital position of a proposed network in the MSS.</p>		

TABLE 5-1 (continued) (Rev. WRC-19)

Reference of Article 9	Case	Frequency bands (and Region) of the service for which coordination is sought	Threshold/condition	Calculation method	Remarks
No. 9.7 GSO/GSO (cont.)		4) 17.3-17.7 GHz (Regions 1 and 2)	i) Bandwidth overlap, and ii) a) any network in the FSS and any associated space operation functions (see No. 1.23) with a space station within an orbital arc of $\pm 8^\circ$ of the nominal orbital position of a proposed network in the BSS, or b) any network in the BSS and any associated space operation functions (see No. 1.23) with a space station within an orbital arc of $\pm 8^\circ$ of the nominal orbital position of a proposed network in the FSS		
		5) 17.7-17.8 GHz	i) Bandwidth overlap, and ii) a) any network in the FSS and any associated space operation functions (see No. 1.23) with a space station within an orbital arc of $\pm 8^\circ$ of the nominal orbital position of a proposed network in the BSS, or b) any network in the BSS and any associated space operation functions (see No. 1.23) with a space station within an orbital arc of $\pm 8^\circ$ of the nominal orbital position of a proposed network in the FSS		

NOTE – No. 5.517 applies in Region 2.

TABLE 5-1 (continued) (Rev. WRC-19)

Reference of Article 9	Case	Frequency bands (and Region) of the service for which coordination is sought	Threshold/condition	Calculation method	Remarks
No. 9.7 GSO/GSO (cont.)		<p>6) 18.0-18.3 GHz (Region 2) 18.1-18.4 GHz (Regions 1 and 3)</p> <p>6bis) 21.4-22 GHz (Regions 1 and 3)</p> <p>7) Bands above 17.3 GHz, except those defined in 3), 3bis) and 6)</p>	<p>i) Bandwidth overlap, and any network in the FSS or meteorological-satellite service and any associated space operation functions (see No. 1.23) with a space station within an orbital arc of <math>\pm 8^\circ</math> of the nominal orbital position of a proposed network in the FSS or the meteorological-satellite service</p> <p>ii) Bandwidth overlap; and any network in the BSS and any associated space operation functions (see No. 1.23) with a space station within an orbital arc of <math>\pm 12^\circ</math> of the nominal orbital position of a proposed network in the BSS (see also Resolutions 554 (WRC-12) and 553 (WRC-12)).</p> <p>i) Bandwidth overlap, and any network in the FSS and any associated space operation functions (see No. 1.23) with a space station within an orbital arc of <math>\pm 8^\circ</math> of the nominal orbital position of a proposed network in the FSS (see also Resolution 901 (Rev. WRC-07))</p>		No. 9.41 does not apply.

TABLE 5-1 (continued) (Rev. WRC-19)

Reference of Article 9	Case	Frequency bands (and Region) of the service for which coordination is sought	Threshold/condition	Calculation method	Remarks
No. 9.7 GSO/GSO (cont.)		<p>8) Bands above 17.3 GHz except those defined in 4), 5) and 6<i>bis</i>)</p> <p>9) All frequency bands, other than those in 1), 2), 2<i>bis</i>), 3), 3<i>bis</i>), 4), 5), 6), 6<i>bis</i>), 7) and 8), allocated to a space service, and the frequency bands in 1), 2), 2<i>bis</i>), 3), 3<i>bis</i>), 4), 5), 6), 6<i>bis</i>), 7) and 8) where the radio service of the proposed network or affected networks is other than the space services listed in the threshold/condition column, or in the case of coordination of space stations operating in the opposite direction of transmission</p>	<p>i) Bandwidth overlap, and</p> <p>ii) any network in the FSS or BSS, not subject to a Plan, and any associated space operation functions (see No. 1.23) with a space station within an orbital arc of <math>\pm 16^\circ</math> of the nominal orbital position of a proposed network in the FSS or BSS, not subject to a Plan, except in the case of a network in the FSS with respect to a network in the FSS (see also Resolution 901 (Rev. WRC-07))</p> <p>i) Bandwidth overlap, and</p> <p>ii) Value of <math>\Delta T/T</math> exceeds 6%</p>	Appendix 8	<p>In application of Article 2A of Appendix 30 for the space operation functions using the guardbands defined in § 3.9 of Annex 5 of Appendix 30, the threshold/condition specified for the FSS in the frequency bands in 2) applies. In application of Article 2A of Appendix 30A for the space operation functions using the guardbands defined in § 3.1 and 4.1 of Annex 3 of Appendix 30A, the threshold/condition specified for the FSS in the frequency bands in 2) and 7) applies, as appropriate</p>

TABLE 5-1 (continued) (Rev.WRC-19)

Reference of Article 9	Case	Frequency bands (and Region) of the service for which coordination is sought	Threshold/condition	Calculation method	Remarks
No. 9.7A GSO earth station/ non-GSO system	A specific earth station in a GSO satellite network in the FSS in respect of a non-GSO satellite system in the FSS	10.7-11.7 GHz (space-to-Earth) 11.7-12.2 GHz (space-to-Earth) in Region 2 12.2-12.75 GHz (space-to-Earth) in Region 3 12.5-12.75 GHz (space-to-Earth) in Region 1 17.8-18.6 GHz (space-to-Earth), and 19.7-20.2 GHz (space-to-Earth)	i) Bandwidths overlap, and  ii) the GSO satellite network has specific receive earth stations which meet all of the following conditions: a) earth station antenna maximum isotropic gain greater than or equal to 64 dBi for the frequency bands 10.7-12.75 GHz or 68 dBi for the frequency bands 17.8-18.6 GHz and 19.7-20.2 GHz; b) $G/T$ of 44 dB/K or higher; c) emission bandwidth of 250 MHz or higher for the frequency bands below 12.75 GHz or 800 MHz or higher for the frequency bands above 17.8 GHz; and	i) Check by using the assigned frequencies and bandwidths; ii) use the maximum antenna gain ( $G$ ), the lowest total receiving system noise temperature ( $T$ ), and the emission bandwidth of the specific receive earth station as given in the Appendix 4 data; and	The threshold/condition for coordination does not apply to typical receive earth stations operating in GSO satellite networks

TABLE 5-1 (continued) (Rev.WRC-19)

Reference of Article 9	Case	Frequency bands (and Region) of the service for which coordination is sought	Threshold/condition	Calculation method	Remarks
No. 9.7A GSO earth station/ non-GSO system (cont.)			iii) the equivalent power flux-density, $epfd_{\downarrow}$ , from the non-GSO satellite system exceeds: a) in the frequency band 10.7-12.75 GHz: -174.5 dB(W/(m <sup>2</sup> · 40 kHz)) for any percentage of time for non-GSO satellite systems with all satellites only operating at or below 2 500 km altitude, or -202 dB(W/(m <sup>2</sup> · 40 kHz)) for any percentage of the time for non-GSO satellite systems with any satellites operating above 2 500 km altitude; b) in the frequency bands 17.8-18.6 GHz or 19.7-20.2 GHz: -157 dB(W/(m <sup>2</sup> · MHz)) for any percentage of time for non-GSO satellite systems with all satellites only operating at or below 2 500 km altitude, or -185 dB(W/(m <sup>2</sup> · MHz)) for any percentage of the time for non-GSO satellite systems with any satellites operating above 2 500 km altitude	iii) use the $epfd_{\downarrow}$ radiated by the non-GSO FSS satellite system into the earth station employing the very large antenna when this antenna is pointed towards the wanted GSO satellite	

TABLE 5-1 (continued) (Rev.WRC-19)

Reference of Article 9	Case	Frequency bands (and Region) of the service for which coordination is sought	Threshold/condition	Calculation method	Remarks
No. 9.7B Non-GSO system/GSO earth station	A non-GSO satellite system in the FSS in respect of a specific earth station in a GSO satellite network in the FSS	10.7-11.7 GHz (space-to-Earth) 11.7-12.2 GHz (space-to-Earth) in Region 2 12.2-12.75 GHz (space-to-Earth) in Region 3 12.5-12.75 GHz (space-to-Earth) in Region 1 17.8-18.6 GHz (space-to-Earth), and 19.7-20.2 GHz (space-to-Earth)	<p>i) Bandwidths overlap, and</p> <p>ii) the GSO satellite network has specific receive earth stations which meet all of the following conditions:</p> <p>a) earth station antenna maximum isotropic gain greater than or equal to 64 dBi for the frequency bands 10.7-12.75 GHz or 68 dBi for the frequency bands 17.8-18.6 GHz and 19.7-20.2 GHz;</p> <p>b) <math>G/T</math> of 44 dB/K or higher;</p> <p>c) emission bandwidth of 250 MHz or higher for the frequency bands below 12.75 GHz or 800 MHz or higher for the frequency bands above 17.8 GHz; and</p>	<p>i) Check by using the assigned frequencies and bandwidths;</p> <p>ii) use the maximum antenna gain (<math>G</math>), the lowest total receiving system noise temperature (<math>T</math>), and the emission bandwidth of the specific receive earth station as given in the Appendix 4 data;</p>	The threshold/condition for coordination do not apply to typical receive earth stations operating in GSO satellite networks



TABLE 5-1 (continued) (Rev.WRC-19)

Reference of Article 9	Case	Frequency bands (and Region) of the service for which coordination is sought	Threshold/condition	Calculation method	Remarks
<p>No. 9.7B Non-GSO system/GS O earth station (cont.)</p>			<p>iii) the epi/d, from the non-GSO satellite system exceeds: a) in the frequency band 10.77-12.75 GHz: -174.5 dB(W/(m<sup>2</sup> · 40 kHz)) for any percentage of time for non-GSO satellite systems with all satellites only operating at or below 2 500 km altitude, or -202 dB(W/(m<sup>2</sup> · 40 kHz)) for any percentage of the time for non-GSO satellite systems with any satellites operating above 2 500 km altitude; b) in the frequency bands 17.8-18.6 GHz or 19.7-20.2 GHz: -157 dB(W/(m<sup>2</sup> · MHz)) for any percentage of time for non-GSO satellite systems with all satellites only operating at or below 2 500 km altitude, or -185 dB(W/(m<sup>2</sup> · MHz)) for any percentage of the time for non-GSO satellite systems with any satellites operating above 2 500 km altitude</p>	<p>iii) use the epi/d radiated by the non-GSO FSS satellite system into the earth station employing the very large antenna when this antenna is pointed towards the wanted GSO satellite</p>	

TABLE 5-1 (continued) (REV.WRC-19)

Reference of Article 9	Case	Frequency bands (and Region) of the service for which coordination is sought	Threshold/condition	Calculation method	Remarks
No. 9.11 GSO, non-GSO/ terrestrial	A space station in the BSS in any band shared on an equal primary basis with terrestrial services and where the BSS is not subject to a Plan, in respect of terrestrial services	1 452-1 492 MHz 2 310-2 360 MHz (No. 5.393) 2 535-2 655 MHz (Nos. 5.417A and 5.418) 17.7-17.8 GHz (Region 2) 74-76 GHz	Bandwidths overlap: The detailed conditions for the application of No. 9.11 in the bands 2 630-2 655 MHz and 2 605-2 630 MHz are provided in Resolution 539 (Rev.WRC-19) for non-GSO BSS (sound) systems pursuant to Nos. 5.417A and 5.418, and in Nos. 5.417A and 5.418 for GSO BSS (sound) networks pursuant to those provisions.  The detailed conditions for the application of No. 9.11 in the frequency band 1 452-1 492 MHz are provided in Resolution 761 (Rev.WRC-19) for Regions 1 and 3.	Check by using the assigned frequencies and bandwidths	
No. 9.12 Non-GSO/ non-GSO	A station in a non-GSO satellite network in the frequency bands for which a footnote refers to No. 9.11A or No. 9.12, in respect of any other non-GSO satellite network, with the exception of coordination between earth stations operating in the opposite direction of transmission	Footnote refers to No. 9.11A or No. 9.12	Bandwidths overlap	Check by using the assigned frequencies and bandwidths	

TABLE 5-1 (continued) (Rev.WRC-19)

Reference of Article 9	Case	Frequency bands (and Region) of the service for which coordination is sought	Threshold/condition	Calculation method	Remarks
No. 9.12A Non-GSO/ GSO	A station in a non-GSO satellite network in the frequency bands for which a footnote refers to No. 9.11A or No. 9.12A, in respect of any GSO satellite network, with the exception of coordination between earth stations operating in the opposite direction of transmission	Frequency bands for which a footnote refers to No. 9.11A or No. 9.12A	Bandwidths overlap	Check by using the assigned frequencies and bandwidths	
No. 9.13 GSO/ non-GSO	A station in a GSO satellite network in the frequency bands for which a footnote refers to No. 9.11A or No. 9.13, in respect of any other non-GSO satellite network, with the exception of coordination between earth stations operating in the opposite direction of transmission	Frequency bands for which a footnote refers to No. 9.11A or No. 9.13	1) Bandwidths overlap 2) For the band 1 668-1 668.4 MHz with respect to MSS network coordination with <b>SRS</b> (passive) networks, in addition to bandwidth overlap, the e.i.r.p. spectral density of mobile earth stations in a GSO network of the mobile-satellite service operating in this band exceeds $-2.5$ dB(W/4 kHz) or the power spectral density delivered to the mobile earth station antenna exceeds $-10$ dB(W/4 kHz)	1) Check by using the assigned frequencies and bandwidths 2) Check by using MSS network Appendix 4 data	

TABLE 5-1 (continued) (Rev.WRC-19)

Reference of Article 9	Case	Frequency bands (and Region) of the service for which coordination is sought	Threshold/condition	Calculation method	Remarks
No. 9.14 Non-GSO/ terrestrial, GSO/ terrestrial	A space station in a satellite network in the frequency bands for which a footnote refers to No. 9.11A or to No. 9.14, in respect of stations of terrestrial services where threshold(s) is (are) exceeded	1) Frequency bands for which a footnote refers to No. 9.11A; or 2) 11.7-12.2 GHz (Region 2 GSO FSS) 3) 5 030-5 091 MHz	1) See § 1 of Annex 1 to this Appendix; In the bands specified in No. 5.414A, the detailed conditions for the application of No. 9.14 are provided in No. 5.414A for MSS networks or 2) In the band 11.7-12.2 GHz (Region 2 GSO FSS): -124 dB(W/(m <sup>2</sup> · MHz)) for 0° ≤ θ ≤ 5° -124 + 0.5(θ - 5) dB(W/(m <sup>2</sup> · MHz)) for 5° < θ ≤ 25° -114 dB(W/(m <sup>2</sup> · MHz)) for θ > 25° where θ is the angle of arrival of the incident wave above the horizontal plane (degrees) 3) Bandwidth overlap	1) See § 1 of Annex 1 to this Appendix	
No. 9.15 Non-GSO/ terrestrial	A specific earth station or a typical earth station, in respect of terrestrial stations in frequency bands for which a footnote refers to No. 9.11A allocated with equal rights to space and terrestrial services, where the coordination area of the earth station includes the territory of another country	Frequency bands for which a footnote refers to No. 9.11A	The coordination area of the earth station covers the territory of another administration	Appendix 7	

TABLE 5-1 (continued) (Rev. WRC-19)

Reference of Article 9	Case	Frequency bands (and Region) of the service for which coordination is sought	Threshold/condition	Calculation method	Remarks
No. 9.16 Terrestrial/ non-GSO	A transmitting station in a terrestrial service within the coordination area of an earth station in a non-GSO satellite network in frequency bands for which a footnote refers to No. 9.II.A	Frequency bands for which a footnote refers to No. 9.II.A	Transmitting terrestrial station is situated within the coordination area of a receiving earth station		The coordination area of the affected earth station has already been determined using the calculation method of Appendix 7
No. 9.17 GSO, non-GSO/ terrestrial	A specific earth station or a typical mobile earth station in frequency bands above 100 MHz allocated with equal rights to space and terrestrial services, in respect of terrestrial stations, where the coordination area of the earth station includes the territory of another country, with the exception of the coordination under No. 9.15	Any frequency band allocated to a space service	The coordination area of the earth station covers the territory of another administration	Appendix 7	

TABLE 5-1 (continued) (Rev.WRC-19)

Reference of Article 9	Case	Frequency bands (and Region) of the service for which coordination is sought	Threshold/condition	Calculation method	Remarks
No. 9.17A GSO, non-GSO/ GSO, non-GSO	A specific earth station in respect of other earth stations operating in the opposite direction of transmission or for any typical mobile earth station in respect of specific earth stations operating in the opposite direction of transmission in frequency bands allocated with equal rights to space radiocommunication services in both directions of transmission, where the coordination area of the earth station includes the territory of another country or the earth station is located within the coordination area of a coordinated earth station, with the exception of coordination under No. 9.19	Any frequency band allocated to a space service	The coordination area of the earth station covers the territory of another administration or the earth station is located within the coordination area of an earth station	Appendix 7	
No. 9.18 Terrestrial/ GSO, non-GSO	Any transmitting station of a terrestrial service in the bands referred to in No. 9.17 within the coordination area of an earth station, in respect of this earth station, with the exception of the coordination under Nos. 9.16 and 9.19	Any frequency band allocated to a space service	Transmitting terrestrial station is situated within the coordination area of a receiving earth station	See Remarks column	The coordination area of the affected earth station has already been determined using the calculation method of No. 9.17

TABLE 5-1 (continued) (Rev.WRC-19)

Reference of Article 9	Case	Frequency bands (and Region) of the service for which coordination is sought	Threshold/condition	Calculation method	Remarks
<p>No. 9.19 Terrestrial, GSO, non-GSO/GSO, non-GSO</p>	<p>Any transmitting station of a terrestrial service or a transmitting earth station in the FSS (Earth-to-space) in a frequency band shared on an equal primary basis with the BSS, with respect to typical earth stations included in the service area of a space station in the BSS</p>	<p>1 452-1 492 MHz 2 310-2 360 MHz (terrestrial services in all three Regions in respect of BSS allocation in No. 5.393) 2 520-2 670 MHz (see No. 5.416) 11.7-12.7 GHz (see Article 6 of Appendix 30) 12.5-12.7 GHz (terrestrial services in Nos. 5.494 and 5.496 as well as in Regions 2 and 3, or transmitting earth station in the FSS (Earth-to-space) in Region 1, in respect of BSS allocation in Region 3) 12.7-12.75 GHz (terrestrial services in Nos. 5.494 and 5.496 as well as in Regions 2 and 3, or transmitting earth station in the FSS (Earth-to-space) in Regions 1 and 2, in respect of BSS allocation in Region 3) 17.7-17.8 GHz (terrestrial services in all three Regions in respect of BSS allocation in Region 2)</p>	<p>i) Necessary bandwidths overlap, and ii) the power flux-density (pfd) of the interfering station at the edge of the BSS service area exceeds the permissible level</p>	<p>Check by using the assigned frequencies and bandwidths</p>	<p>See also Article 6 of Appendix 30</p>

TABLE 5-1 (end) (Rev.WRC-19)

Reference of Article 9	Case	Frequency bands (and Region) of the service for which coordination is sought	Threshold/condition	Calculation method	Remarks
No. 9.19 Terrestrial, GSO, non-GSO/ GSO, non-GSO ( <i>cont.</i> )		17.3-17.8 GHz (transmitting earth stations in the FSS (Earth-to-space) in respect of BSS allocation in Region 2) (see Article 4 of Appendix 30A) 40.5-42.5 GHz 74-76 GHz			
No. 9.21 Terrestrial, GSO, non-GSO/ terrestrial, GSO, non-GSO	A station of a service for which the requirement to obtain the agreement of other administrations is included in a footnote to the Table of Frequency Allocations referring to No. 9.21	Band(s) indicated in the relevant footnote except 13.4-13.65 GHz in Region 1  13.4-13.65 GHz in Region 1 indicated in No. 5.499A	Incompatibility established by the use of Appendices 7, 8, technical Annexes of Appendices 30 or 30A, pfd values specified in some of the footnotes, other technical provisions of the Radio Regulations or ITU-R Recommendations, as appropriate i) Bandwidth overlap, and ii) any network in the space research service (SRS) with a space station within an orbital arc of $\pm 20^\circ$ of the nominal orbital position of a proposed network in the FSS	Methods specified in, or adapted from, Appendices 7, 8, 30, 30A, other technical provisions of the Radio Regulations or ITU-R Recommendations	



# 1 Coordination thresholds for sharing between MSS (space-to-Earth) and terrestrial services in the same frequency bands and between non-GSO MSS feeder links (space-to-Earth) and terrestrial services in the same frequency bands and between RDSS (space-to-Earth) and terrestrial services in the same frequency bands <sup>(WRC-12)</sup>

## 1.1 Below 1 GHz\*

1.1.1 In the bands 137-138 MHz and 400.15-401 MHz, coordination of a space station of the MSS (space-to-Earth) with respect to terrestrial services (except aeronautical mobile (OR) service networks operated by the administrations listed in Nos. **5.204** and **5.206** as of 1 November 1996) is required only if the pfd produced by this space station exceeds  $-125 \text{ dB(W/(m}^2 \cdot 4 \text{ kHz))}$  at the Earth's surface.

1.1.2 In the band 137-138 MHz, coordination of a space station of the MSS (space-to-Earth) with respect to the aeronautical mobile (OR) service is required only if the pfd produced by this space station at the Earth's surface exceeds:

- $-125 \text{ dB(W/(m}^2 \cdot 4 \text{ kHz))}$  for networks for which complete Appendix **3\*\*** coordination information has been received by the Bureau prior to 1 November 1996;
- $-140 \text{ dB(W/(m}^2 \cdot 4 \text{ kHz))}$  for networks for which complete Appendix **4/S4/3\*\*** coordination information has been received by the Bureau after 1 November 1996 for the administrations referred to in § 1.1.1 above.

1.1.3 In the band 137-138 MHz, coordination is also required for a space station on a replacement satellite of a MSS network for which complete Appendix **3\*\*** coordination information has been received by the Bureau prior to 1 November 1996 and the pfd exceeds  $-125 \text{ dB(W/(m}^2 \cdot 4 \text{ kHz))}$  at the Earth's surface for the administrations referred to in § 1.1.1 above.

## 1.2 Between 1 and 3 GHz

### 1.2.1 Objectives

Generally, pfd thresholds were used to determine the need for coordination between space stations of the MSS (space-to-Earth) and terrestrial services and for coordination between space stations of the RDSS (space-to-Earth) and terrestrial services. However, to facilitate sharing between digital fixed service stations and non-GSO MSS space stations, the concept of fractional degradation in performance (FDP) was adopted. This concept involves new methods described in this Annex.

---

\* These provisions apply only to the MSS.

\*\* *Note by the Secretariat:* Edition of 1990, revised in 1994.

As a consequence of this new concept, the need for coordination between space stations of the MSS (space-to-Earth) and terrestrial services is determined using two methods:

- simple method: FDP (simple definition of the MSS system and characteristics of reference FS stations are used in inputs) or power flux-density trigger value;
- more detailed method: system specific methodology (SSM) (specific characteristics of the MSS system and characteristics of reference fixed service stations are used in inputs) as described, for example, in Annex 1 to the most recent version of Recommendation ITU-R M.1143.

If one of the two methods gives a result that does not exceed the criteria relevant to each method, there is no need for coordination.

If only one method is available in an administration, the result of this method must be taken into account. (WRC-15)

## 1.2.2 General considerations

### 1.2.2.1 Method for calculating the value of FDP

The FDP is used in cases of sharing between digital fixed service stations with non-GSO MSS stations (space-to-Earth).

To calculate the value of the FDP, the following parameters are needed:

- technical characteristics of digital fixed service station;
- technical characteristics of non-GSO MSS constellation.

The FDP is calculated:

- by simulating the proposed MSS constellation using the information given in § A.4 of Annex 2 to Appendix 4;
- by positioning the fixed service station at a certain latitude (each station is assumed to operate at an elevation angle of 0°);
- by calculating for each pointing azimuth ( $Az$ ) varying between 0° and 360°:
  - at each instant in time of the simulation, the aggregate interference from all visible space stations received at the fixed service station;
  - the  $FDP_{Az}$  for the azimuth  $Az$ , using the following formula:

$$FDP_{Az} = \sum_{I_i = \min}^{\max} \frac{I_i f_i}{N_T}$$

– by the following formula:

$$FDP = \max(FDP_{Az})$$

(The formula for FDP applies to the 1-3 GHz frequency range only. A different formula may apply at frequencies above 3 GHz.)

where:

$I_i$ : interference noise power level (W)

$f_i$ : the fractional period of time during which the interference power equals  $I_i$

$N_f$ : station receiving system noise power level =  $kTB$  (W)

$k$ : Boltzmann's constant =  $1.38 \times 10^{-23}$  (J/K)

$T$ : FS station receiving system effective noise temperature ( $T$  should be calculated by the following formula:

$$10 \log T = NF + 10 \log T_0$$

where  $NF$  (dB) is the receiver noise figure given in Annex 1 and  $T_0$  should be assumed as 290 K)

$B$ : reference bandwidth = 1 MHz.

NOTE – For the purpose of FDP calculation according to this Annex, it should be assumed that all space stations in the same MSS constellation operate on the same frequencies.

### 1.2.2.2 Characteristics of reference systems in the fixed service

The following parameters represent the set of reference parameters of the fixed service.

#### 1.2.2.2.1 Characteristics of reference digital point-to-point systems

Three different digital systems are described in the following Table:

- 64 kbit/s capacity used, for example, for outside plant (individual subscriber connection);
- 2 Mbit/s capacity used, for example, for business subscriber connections for the local part of the inside plant;
- 45 Mbit/s capacity used, for example, for trunk networks.

Capacity	64 kbit/s	2 Mbit/s	45 Mbit/s
Modulation	4-PSK	8-PSK	64-QAM
Antenna gain (dB)	33	33	33
Transmit power (dBW)	7	7	1
Feeder/multiplexer loss (dB)	2	2	2
e.i.r.p. (dBW)	38	38	32
Receiver IF bandwidth (MHz)	0.032	0.7	10
Receiver noise figure (dB)	4	4.5	4
Receiver input level for a BER of $10^{-3}$ (dBW)	-137	-120	-106

Antenna pattern:

$$G(\varphi) = G_{max} - 2.5 \times 10^{-3} \left( \frac{D\varphi}{\lambda} \right)^2 \quad \text{for } 0 < \varphi < \varphi_m$$

$$G(\varphi) = 39 - 5 \log(D/\lambda) - 2.5 \log \varphi \quad \text{for } \varphi_m \leq \varphi < 48^\circ$$

$$G(\varphi) = -3 - 5 \log(D/\lambda) \quad \text{for } 48^\circ \leq \varphi \leq 180^\circ$$

where:

$G(\varphi)$ : gain relative to an isotropic antenna (dBi)

$\varphi$ : off-axis angle (degrees)

$D$ : antenna diameter

$\lambda$ : wavelength expressed in the same unit as  $D$

$G_1$ : gain of the first side-lobe =  $2 + 15 \log(D/\lambda)$

( $D/\lambda$  may be estimated from  $20 \log(D/\lambda) \approx G_{max} - 7.7$ )

$G_{max}$ : main lobe antenna gain (dBi)

$$\varphi_m = 20 (\lambda/D) \times \sqrt{(G_{max} - G_1)}$$

It should be noted that the above antenna radiation pattern corresponds to the average side-lobe pattern and it is recognized that individual side-lobes may exceed it by up to 3 dB.

### 1.2.2.2.2 Characteristics of reference analogue point-to-point systems

Reference circuit	12 hops with 50 km distance between stations
Antenna gain (dBi)	33
e.i.r.p. (dBW)	36
Feeder/multiplexer loss (dB)	3
Receiver noise figure (referred to input of receiver) (dB)	8
Maximum short- and long-term interference in the reference circuit: <ul style="list-style-type: none"> <li>- baseband interfering signal power level not to be exceeded for more than 20% of the time</li> <li>- baseband interfering signal power level not to be exceeded for more than 0.01% of the time</li> </ul>	<p>240 pW0p</p> <p>50 000 pW0p</p>

Antenna pattern: use antenna pattern of § 1.2.2.2.1.

**1.2.2.2.3 Characteristics of reference point-to-multipoint systems**

NOTE – In application of the standard computation program, the use of the point-to-multipoint reference fixed service system parameters for the 2 170-2 200 MHz band is not required.

Parameter	Central station	Outstation
Antenna type	Omni/sectoral	Dish/horn
Antenna gain (dBi)	10/13	20 (analogue) 27 (digital)
e.i.r.p. (max) (dBW):		
– analogue	12	21
– digital	24	34
Noise figure (dB)	3.5	3.5
Feeder/multiplexer loss (dB)	2	2
IF bandwidth (MHz)	3.5	3.5

*Antenna pattern:*

For the outstation antenna pattern, the reference pattern described in § 1.2.2.2.1 is to be used.

The reference radiation pattern for omnidirectional or sectoral antennas is the following:

$$G(\theta) = G_0 - 12 (\theta/\varphi_3)^2 \quad \text{for } 0 \leq \theta < \varphi_3$$

$$G(\theta) = G_0 - 12 - 10 \log (\theta/\varphi_3) \quad \text{for } \varphi_3 \leq \theta < 90^\circ$$

where:

- $G_0$ : maximum gain in the horizontal plane (dBi)
- $\theta$ : radiation angle above the horizontal plane (degrees)
- $\varphi_3$  (degrees) is given by:

$$\varphi_3 = \frac{1}{\alpha^2 - 0.818}$$

where:

$$\alpha = \frac{10^{0.1G_0 + 172.4}}{191}$$

**1.2.3 Determination of the need for coordination between MSS and RDSS space stations (space-to-Earth) and terrestrial stations (WRC-12)**

**1.2.3.1 Method for the determination of the need for coordination between MSS and RDSS space stations (space-to-Earth) and other terrestrial services sharing the same frequency band in the 1 to 3 GHz range**

Coordination of assignments for transmitting space stations of the MSS and RDSS with respect to terrestrial services is not required if the pfd produced at the Earth’s surface or the FDP of a station in the fixed service does not exceed the threshold values shown in the following table. (WRC-12)

TABLE 5-2 (Rev.WRC-19)

Frequency band (MHz)	Terrestrial service to be protected	Coordination threshold values				
		GSO space stations		Non-GSO space stations		
		pfd (per space station) calculation factors (NOTE 2)		pfd (per space station) calculation factors (NOTE 2)		% FDP (in 1 MHz) (NOTE 1)
		<i>P</i>	<i>r</i> dB/degrees	<i>P</i>	<i>r</i> dB/degrees	
1 518-1 525	Analogue FS telephony (NOTE 5)	-146 dB(W/m <sup>2</sup> ) in 4 kHz and -128 dB(W/m <sup>2</sup> ) in 1 MHz	0.5	-146 dB(W/m <sup>2</sup> ) in 4 kHz and -128 dB(W/m <sup>2</sup> ) in 1 MHz	0.5	
	All other cases FS telephony (NOTES 4 and 8)	-128 dB(W/m <sup>2</sup> ) in 1 MHz	0.5	-128 dB(W/m <sup>2</sup> ) in 1 MHz	0.5	25
1 525-1 530	Analogue FS telephony (NOTE 5)	-146 dB(W/m <sup>2</sup> ) in 4 kHz and -128 dB(W/m <sup>2</sup> ) in 1 MHz	0.5	-146 dB(W/m <sup>2</sup> ) in 4 kHz and -128 dB(W/m <sup>2</sup> ) in 1 MHz	0.5	
	All other cases	-128 dB(W/m <sup>2</sup> ) in 1 MHz	0.5	-128 dB(W/m <sup>2</sup> ) in 1 MHz	0.5	25
2 160-2 200  (NOTE 3)	Analogue FS telephony (NOTE 5)	-146 dB(W/m <sup>2</sup> ) in 4 kHz and -128 dB(W/m <sup>2</sup> ) in 1 MHz	0.5	-141 dB(W/m <sup>2</sup> ) in 4 kHz and -123 dB(W/m <sup>2</sup> ) in 1 MHz (NOTE 6)	0.5	
	All other cases	-128 dB(W/m <sup>2</sup> ) in 1 MHz	0.5	-123 dB(W/m <sup>2</sup> ) in 1 MHz (NOTE 6)	0.5	25
2 483.5-2 500 (mobile-satellite service)	All cases	-146 dB(W/m <sup>2</sup> ) in 4 kHz and -128 dB(W/m <sup>2</sup> ) in 1 MHz	0.5	-144 dB(W/m <sup>2</sup> ) in 4 kHz and -126 dB(W/m <sup>2</sup> ) in 1 MHz (NOTE 9)	0.65	
2 483.5-2 500 (radiodetermination-satellite service) (NOTE 10)	All cases except the radiolocation service in the countries listed in No. <b>5.398A</b>	-152 dB(W/m <sup>2</sup> ) in 4 kHz -128 dB(W/m <sup>2</sup> ) in 1 MHz	–	-153 dB(W/m <sup>2</sup> ) in 4 kHz -129 dB(W/m <sup>2</sup> ) in 1 MHz (NOTE 9)		
2 500-2 520 (SUP - WRC-07)						
2 520-2 535 (SUP - WRC-07)						

Notes for Table 5-2:

NOTE 1 – The calculation of FDP is contained in § 1.2.2.1, using the reference FS parameters contained in § 1.2.2.2.1 and 1.2.2.3. The use of FDP threshold is limited to the case of digital FS systems.

NOTE 2 – The following formula should be used for deriving the coordination threshold in terms of pfd:

$$\begin{array}{lll}
 P & \text{for} & 0^\circ \leq \delta \leq 5^\circ \\
 P + r(\delta - 5) & \text{for} & 5^\circ < \delta \leq 25^\circ \\
 P + 20r & \text{for} & 25^\circ < \delta \leq 90^\circ
 \end{array}$$

where  $\delta$  is the angle of arrival (degrees).

The threshold values are obtained under assumed free-space propagation conditions.

NOTE 3 – The coordination thresholds in the band 2 160-2 170 MHz (Region 2) and 2 170-2 200 MHz (all Regions) to protect other terrestrial services do not apply to International Mobile Telecommunications (IMT) systems, as the satellite and the terrestrial components are not intended to operate in the same area or on common frequencies within these bands. (WRC-12)

NOTE 4 – Exceptions for the band 1 518-1 525 MHz are as follows:

4.1 For the land mobile service on the territory of Japan (No. **5.348A**):  $-150 \text{ dB(W/m}^2\text{)}$  in 4 kHz at all angles of arrival is applicable to all satellite space-to-Earth emissions.

4.2 For the aeronautical mobile service for telemetry on the territory of the administrations listed in No. **5.342**:  $-140 \text{ dB(W/m}^2\text{)}$  in 4 kHz at all angles of arrival.

4.3 For the point-to-multipoint systems operating in the fixed service in the territory of New Zealand:  $-138 \text{ dB(W/m}^2\text{)}$  in 1 MHz for angles of arrival less than or equal to  $5^\circ$  above the horizon and increasing linearly to  $-125 \text{ dB(W/m}^2\text{)}$  in 1 MHz for angles of arrival equal to  $25^\circ$  or greater above the horizon. (WRC-03)

NOTE 5 – In all cases involving sharing with analogue systems for telephony in the FS, further coordination is only required when the pfd values are greater than or equal to the coordination threshold values in both reference bandwidths.

NOTE 6 – The pfd values specified for the band 2 160-2 200 MHz provide full protection for analogue radio-relay systems using the sharing criteria established by the most recent version of Recommendation ITU-R SF.357, for operation with a non-GSO MSS system employing narrow-band time division multiple access/frequency division multiple access techniques.

NOTE 7 – (SUP - WRC-12)

NOTE 8 – In the band 1 518-1 520 MHz, for the point-to-multipoint systems operating in the fixed service on the territory of Australia:  $-138 \text{ dB(W/m}^2\text{)}$  in 1 MHz for angles of arrival less than or equal to  $5^\circ$  above the horizon and increasing linearly to  $-125 \text{ dB(W/m}^2\text{)}$  in 1 MHz for angles of arrival equal to  $25^\circ$  or greater above the horizon. (WRC-03)

NOTE 9 – Instead of the values in the Table, the pfd coordination thresholds of  $-142.5 \text{ dB(W/m}^2\text{)}$  in 4 kHz and  $-124.5 \text{ dB(W/m}^2\text{)}$  in 1 MHz for the MSS and  $-152 \text{ dB(W/m}^2\text{)}$  in 4 kHz and  $-128 \text{ dB(W/m}^2\text{)}$  in 1 MHz for the RDSS shall apply in Albania, Germany, Andorra, Antigua and Barbuda, Argentina, Australia, Austria, Bahamas, Barbados, Belgium, Belize, Bolivia (Plurinational State of), Bosnia and Herzegovina, Brazil, Bulgaria, Canada, Chile, Cyprus, Vatican, Colombia, Congo (Rep. of the), Costa Rica, Croatia, Denmark, Dominican Rep., Dominica, El Salvador, Ecuador, Spain, Estonia, United States, Finland, France, Greece, Grenada, Guatemala, Guyana, Haiti, Honduras, Hungary, Ireland, Iceland, Israel, Italy, Jamaica, Latvia, Liechtenstein, Lithuania, Luxembourg, North Macedonia, Malta, Mexico, Monaco, Montenegro, Nicaragua, Nigeria, Norway, Panama, Paraguay, Netherlands, Peru, Poland, Portugal, Slovakia, Czech Rep., Romania, United Kingdom, Saint Lucia, Saint Kitts and Nevis, San Marino, Saint Vincent and the Grenadines, Serbia, Slovenia, Sweden, Switzerland, Suriname, Trinidad and Tobago, Turkey, Uruguay and Venezuela. (WRC-19)

NOTE 10 – These pfd values apply only to systems submitted after 17 February 2012 and do not apply to systems for which complete coordination information has been received before 18 February 2012 (see No. **5.401**). (WRC-12)

### **1.2.3.2 A system specific methodology (SSM) to be used in determining the need for detailed coordination of non-GSO MSS (space-to-Earth) systems with fixed service systems**

The purpose of the SSM is to allow a detailed assessment of the need to coordinate frequency assignments to non-GSO MSS space stations (space-to-Earth) with frequency assignments to receiving stations in a fixed service network of a potentially affected administration. The SSM takes into account specific characteristics of the non-GSO MSS system and reference fixed service characteristics.

Those administrations planning to establish the need for coordination between non-GSO MSS networks and fixed service systems are encouraged to use the most recent version of Recommendation ITU-R M.1143. While urgent additional development work is being undertaken in the ITU-R to facilitate the use of the methodology described in the most recent version of Recommendation ITU-R M.1143, administrations may be able to effect coordination by applying this SSM. (WRC-15)

**1.3** (SUP - WRC-15)

**2** (SUP - WRC-2000)

**3** (SUP - WRC-2000)





## APPENDIX 7 (REV.WRC-19)

**Methods for the determination of the coordination area around an earth station in frequency bands between 100 MHz and 105 GHz****1 Introduction**

This Appendix addresses the determination of the coordination area (see No. 1.171) around a transmitting or receiving earth station that is sharing spectrum in frequency bands between 100 MHz and 105 GHz with terrestrial radiocommunication services or with earth stations operating in the opposite direction of transmission.

The coordination area represents the area surrounding an earth station sharing the same frequency band with terrestrial stations, or the area surrounding a transmitting earth station that is sharing the same bidirectionally allocated frequency band with receiving earth stations, within which the permissible level of interference may be exceeded and hence coordination is required. The coordination area is determined on the basis of known characteristics for the coordinating earth station and on conservative assumptions for the propagation path and for the system parameters for the unknown terrestrial stations (see Tables 7 and 8), or the unknown receiving earth stations (see Table 9), that are sharing the same frequency band.

NOTE – Throughout this Appendix, the word “unknown”, when applied to terrestrial stations or earth stations, refers to such stations that are potentially located in the coordination area.

**1.1 Overview**

This Appendix contains procedures and system parameters for calculating an earth station’s coordination area, including predetermined distances.

The procedures allow the determination of a distance in all azimuthal directions around a transmitting or receiving earth station beyond which the predicted path loss would be expected to exceed a specified value for all but a specified percentage of the time. This distance is called the coordination distance (see No. 1.173). When the coordination distance is determined for each azimuth around the coordinating earth station it defines a distance contour, called the coordination contour (see No. 1.172), that encloses the coordination area.

It is important to note that, although the determination of the coordination area is based on technical criteria, it represents a regulatory concept. Its purpose is to identify the area within which detailed evaluations of the interference potential need to be performed in order to determine whether the coordinating earth station or any of the terrestrial stations, or in the case of a bidirectional allocation any of the receiving earth stations that are sharing the same frequency band, will experience unacceptable levels of interference. Hence, the coordination area is not an exclusion zone within which the sharing of frequencies between the earth station and terrestrial stations or other earth stations is prohibited, but a means for determining the area within which more detailed calculations need to be performed. In most cases a more detailed analysis will show that sharing within the coordination area is possible since the procedure for the determination of the coordination area is based on unfavourable assumptions with regard to the interference potential.

## AP7-2

For the determination of the coordination area, two separate cases are to be considered:

- case when the earth station is transmitting and hence capable of interfering with receiving terrestrial stations or earth stations;
- case when the earth station is receiving and hence may be the subject of interference from transmitting terrestrial stations.

Calculations are performed separately for great circle propagation mechanisms (propagation mode (1)) and, if required by the sharing scenario (see § 1.4), for scattering from hydrometeors (propagation mode (2)). The coordination contour is then determined using the greater of the two distances predicted by the propagation mode (1) and propagation mode (2) calculations for each azimuth around the coordinating earth station. Separate coordination contours are produced for each sharing scenario. Guidance and examples of the construction of coordination contours, and their component propagation mode (1) and propagation mode (2) contours, are provided in § 1.6.

To facilitate bilateral discussion it can be useful to calculate additional contours, defining smaller areas, that are based on less conservative assumptions than those used for the calculation of the coordination contour.

### 1.2 Structure of this Appendix

In this Appendix the general principles are separated from the detailed text on methods. The general principles are contained in the main body of the Appendix, while the methods are contained in a series of Annexes, enabling the user to select only those sections that are relevant for a specific sharing scenario.

Table 1 is provided to help the user to navigate through the Appendix and the Annexes; it also indicates the relevant sections that need to be explored for a specific coordination case.

TABLE 1

## Cross-reference between sharing scenarios and calculation methods

Applicable sections and Annexes	Sharing scenarios of § 1.4						
	§ 1.4.1 Earth stations operating with geostationary space stations	§ 1.4.2 Earth stations operating with non-geostationary space stations <sup>1</sup>	§ 1.4.3 Earth stations operating with both geostationary and non-geostationary space stations	§ 1.4.4 Earth stations operating in bidirectionally allocated frequency bands	§ 1.4.5 Broadcasting-satellite service earth stations	§ 1.4.6 Mobile (except aeronautical mobile) earth stations	§ 1.4.7 Aeronautical mobile earth stations
§ 1.3 Basic concepts	X	X	X	X	X	X	X
§ 1.5 Propagation model concepts	X	X	X	X			
§ 1.6 The coordination contour: concepts and construction	X	X	X	X			
§ 2.1 Earth stations operating with geostationary space stations	X		X				
§ 2.2 Earth stations operating with non-geostationary space stations		X	X				
§ 3 Determination of the coordination area between earth stations operating in bidirectionally allocated frequency bands					X		
§ 4 General considerations for the determination of the propagation mode (1) required distance	X	X	X	X			
§ 5 General considerations for the determination of the propagation mode (2) required distance	X		X				
Annex 1 Determination of the required distance for propagation mode (1)	X	X	X	X			
Annex 2 Determination of the required distance for propagation mode (2)	X		X				
Annex 3 Antenna gain towards the horizon for an earth station operating with a geostationary space station	X		X				
Annex 4 Antenna gain towards the horizon for earth stations operating with non-geostationary space stations		X	X	X			
Annex 5 Determination of the coordination area for a transmitting earth station with respect to receiving earth stations operating with geostationary space stations in bidirectionally allocated frequency bands					X		
Annex 6 Supplementary and auxiliary contours	X	X	X	X			
Annex 7 System parameters and predetermined coordination distances for determination of the coordination area around an earth station	X	X	X	X			

<sup>1</sup> For an earth station using a non-tracking antenna the procedure of § 2.1 is used. For an earth station using a non-directional antenna the procedures of § 2.1.1 are used.

### 1.3 Basic concepts

Determination of the coordination area is based on the concept of the permissible interference power at the antenna terminals of a receiving terrestrial station or earth station. Hence, the attenuation required to limit the level of interference between a transmitting terrestrial station or earth station and a receiving terrestrial station or earth station to the permissible interference power for  $p\%$  of the time is represented by the “minimum required loss”, which is the loss that needs to be equalled or exceeded by the predicted path loss for all but  $p\%$  of the time<sup>1</sup>.

For propagation mode (1) the following equation applies:

$$L_b(p) = P_t + G_t + G_r - P_r(p) \quad \text{dB} \quad (1)$$

where:

$p$ : maximum percentage of time for which the permissible interference power may be exceeded

$L_b(p)$ : propagation mode (1) minimum required loss (dB) for  $p\%$  of the time; this value must be exceeded by the propagation mode (1) predicted path loss for all but  $p\%$  of the time

$P_t$ : maximum available transmitting power level (dBW) in the reference bandwidth at the terminals of the antenna of a transmitting terrestrial station or earth station

$P_r(p)$ : permissible interference power of an interfering emission (dBW) in the reference bandwidth to be exceeded for no more than  $p\%$  of the time at the terminals of the antenna of a receiving terrestrial station or earth station that may be subject to interference, where the interfering emission originates from a single source

$G_t$ : gain (dB relative to isotropic) of the antenna of the transmitting terrestrial station or earth station. For a transmitting earth station, this is the antenna gain towards the physical horizon on a given azimuth; for a transmitting terrestrial station, the maximum main beam axis antenna gain is to be used

$G_r$ : gain (dB relative to isotropic) of the antenna of the receiving terrestrial or earth station that may be subject to interference. For a receiving earth station, this is the gain towards the physical horizon on a given azimuth; for a receiving terrestrial station, the maximum main beam axis antenna gain is to be used.

In the case of a receiving earth station, the permissible interference power  $P_r(p)$  is specified with respect to the actual percentage of time the receiver is in operation, rather than the total elapsed time.

---

<sup>1</sup> When  $p$  is a small percentage of the time, in the range 0.001% to 1.0%, the interference is referred to as “short-term”; if  $p \geq 20\%$ , it is referred to as “long-term” (see § 1.5.3).

For propagation mode (2), a volume scattering process is involved and a modification of the above approach is necessary. Where the coordinating earth station antenna beam intersects a rain cell, a common volume may be formed with a terrestrial station beam or an earth station beam (operating in the opposite direction of transmission in bidirectionally allocated frequency bands). In the case of a terrestrial station, the assumptions are made that the terrestrial station beamwidth is relatively large in comparison with that of the coordinating earth station (terrestrial station gain values are given in Tables 7 and 8) and that the terrestrial station is some distance from the common volume. The terrestrial station beam is therefore assumed to illuminate the whole rain cell, which is represented by a vertical cylinder filled with hydrometeors that give rise to isotropically scattered signals. This scattering process may give rise to unwanted coupling between the coordinating earth station and terrestrial stations or other earth stations operating in bidirectionally allocated frequency bands, via the common volume.

The earth station antenna gain and its beamwidth are interdependent. The size of the common volume, and the number of scattered signals arising within that volume, increases as the gain of the earth station antenna transmitting or receiving those signals decreases, the one effect compensating for the other. A term which approximates the full integral required to evaluate the volume scattering process within the earth station antenna beam is included in equation (72). Therefore in the procedure for evaluation of interference that may arise from propagation mode (2) mechanisms a simplifying assumption can be made that the path loss is independent of the earth station antenna gain<sup>2</sup>.

Hence for propagation mode (2), equation (1) reduces to:

$$L_x(p) = P_t + G_x - P_r(p) \quad \text{dB} \quad (2)$$

where:

$L_x(p)$ : minimum loss required for propagation mode (2)

$G_x$ : maximum antenna gain (dBi) assumed for the terrestrial station. Tables 7 and 8 give values of  $G_x$  for the various frequency bands.

To facilitate the calculation of propagation mode (2) auxiliary contours (see Annex 6) the calculation is further modified by placing the terrestrial network antenna gain  $G_x$  within the iterative loop for the propagation mode (2) required loss calculations<sup>3</sup>.

Hence equation (2) further reduces to:

$$L(p) = P_t - P_r(p) \quad \text{dB} \quad (3)$$

<sup>2</sup> If the earth station antenna has a wide beamwidth, the method can still be used to determine the propagation mode (2) contour. However, the fact that the antenna beam may be wider than the rain cell and hence not actually fully filled with hydrometeors will mean that the interference potential may be slightly overestimated.

<sup>3</sup> See equation (82).

## AP7-6

where:

$L(p)$ : propagation mode (2) minimum required loss (dB) for  $p\%$  of the time; this value must be exceeded by the propagation mode (2) predicted path loss for all but  $p\%$  of the time.

For both modes of propagation,  $P_t$  and  $P_r(p)$  are defined for the same radio-frequency bandwidth (the reference bandwidth). Further,  $L_b(p)$ ,  $L(p)$  and  $P_r(p)$  are defined for the same small percentage of the time, and these values are set by the performance criteria of the receiving terrestrial station or receiving earth station that may be subject to interference.

For an earth station operating with a geostationary space station, Annex 3 provides the numerical method for determining the minimum angle between the earth station antenna main beam axis and the physical horizon as a function of azimuth, and the corresponding antenna gain. In the case of a space station in a slightly inclined geostationary orbit, the minimum elevation angle and corresponding horizon gain will depend on the maximum inclination angle to be coordinated.

For an earth station operating with non-geostationary space stations, the antenna gain of the earth station in the direction of the horizon varies as a function of time and Annex 4 provides the numerical methods for its determination.

For an earth station operating in a frequency band with a bidirectional allocation, the antenna gain to be used in determining the propagation mode (1) minimum required loss is calculated using the methods in Annex 3 or Annex 4, as appropriate.

Determination of the coordination area requires the calculation of the predicted path loss and its comparison with the minimum required loss, for every azimuth around the coordinating earth station, where:

- the predicted path loss is dependent on several factors including the length and general geometry of the interfering path (e.g. antenna pointing, horizon elevation angle), antenna directivity, radio climatic conditions, and the percentage of the time during which the predicted path loss is less than the minimum required loss; and
- the minimum required loss is based on system and interference model considerations.

The required coordination distance is the distance at which these two losses are considered to be equal for the stated percentage of time.

In determining the coordination area, the pertinent parameters of the coordinating earth station are known, but knowledge of the terrestrial stations or other earth stations sharing that frequency range is limited. Hence it is necessary to rely on assumed system parameters for the unknown terrestrial stations or the unknown receiving earth stations. Furthermore, many aspects of the interference path between the coordinating earth station and the terrestrial stations or other earth stations (e.g. antenna geometry and directivity) are unknown.

The determination of the coordination area is based on unfavourable assumptions regarding system parameter values and interference path geometry. However, in certain circumstances, to assume that all the worst-case values will occur simultaneously is unrealistic, and leads to unnecessarily large values of minimum required loss. This could lead to unnecessarily large coordination areas. For propagation mode (1), detailed analyses, supported by extensive operational experience, have shown that the requirement for the propagation mode (1) minimum required loss can be reduced because of the very small probability that the worst-case assumptions for system parameter values and interference path geometry will exist simultaneously. Therefore, a correction is applied within the calculation for the propagation mode (1) predicted path loss in the appropriate sharing scenario to allow benefit to be derived from these mitigating effects. The application of this correction factor is described in more detail in § 4.4.

This correction applies to cases of coordination with the fixed service. It is frequency, distance and path dependent. It does not apply in the case of the coordination of an earth station with mobile stations, nor with other earth stations operating in the opposite direction of transmission, nor in the case of propagation via hydrometeor scatter (propagation mode (2)).

A number of propagation models are used to cover the propagation mechanisms that exist in the full frequency range. These models predict the path loss as a monotonically increasing function of distance. Therefore, coordination distances are determined by calculating the path loss iteratively for an increasing distance until either the minimum required loss is achieved, or a maximum calculation distance limit is reached (see § 1.5.3).

The iteration method always starts at a defined value of minimum distance,  $d_{min}$  (km), and iteration is performed using a uniform step size,  $s$  (km), for increasing the distance. A step size of 1 km is recommended.

## 1.4 Sharing scenarios

The following subsections describe the basic assumptions made for the various earth station sharing scenarios. These subsections need to be read in conjunction with the information contained in Table 1 and § 1.6 which contains guidance on the development of a coordination contour. Except as discussed in § 1.4.5 to 1.4.7, the earth stations around which coordination areas are determined are assumed to be fixed earth stations authorized to operate at a single permanent location. In cases of earth stations that can be operated from a number of fixed locations, the coordination areas are determined for each individual location.<sup>4</sup>

---

<sup>4</sup> While some fixed satellite systems transmit to fixed earth stations operating at unspecified locations within a service area defined by an administration, methods for determining the coordination areas are specified only for individual sites. To minimize the number of individual earth stations requiring detailed coordination in these cases, administrations may wish to develop bilateral agreements based on distances, calculated in accordance with Recommendation ITU-R SM.1448, extended from the periphery of a service area.



### 1.4.1 Earth stations operating with geostationary space stations

For an earth station operating with a space station in the geostationary orbit, the space station appears to be stationary with respect to the Earth. However variations in gravitational forces acting on the space station and limitations in positional control mean that a geostationary space station's orbital parameters are not constant. Movement from the space station's nominal orbital position in an east/west direction (longitudinal tolerance) is limited under the Radio Regulations (see Nos. **22.6** to **22.18**), but movement in the north/south direction (inclination excursion) is not specified.

Relaxation in the north/south station-keeping of a geostationary space station allows its orbit to become inclined, with an inclination that increases gradually with time. Therefore the determination of the coordination area requires consideration of the range of movement of the earth station antenna. Although the direction of pointing of the earth station antenna may in practice vary with time, the earth station antenna may also be pointing in one direction for considerable periods of time. Hence the gain of the earth station antenna in the direction of the horizon is assumed to be constant. For an earth station operating with a space station in an orbit as described above, an assumption of constant horizon gain as the inclination angle increases may lead to a conservative estimation of the coordination area, the degree of conservatism increasing with increasing inclination angle.

For an earth station operating with a geostationary space station the coordination area is determined using the procedures described in § 2.1.

### 1.4.2 Earth stations operating with non-geostationary space stations

Earth stations operating with non-geostationary space stations may use a directional or a non-directional antenna. Furthermore, earth stations using a directional antenna may track the orbital path of a non-geostationary space station.

While an earth station operating with a geostationary space station is assumed to have a constant antenna gain towards the horizon, for an earth station antenna that is tracking the orbital path of a non-geostationary space station, the antenna gain towards the horizon will vary with time. Therefore, it is necessary to estimate the variation of the antenna gain with time towards the horizon for each azimuth in order to determine the coordination area. The procedure is described in § 2.2.

For an earth station operating with a non-geostationary space station, the motion of a relatively high gain tracking antenna reduces the probability of interference due to propagation mode (2) mechanisms and hence the propagation mode (2) required distances will be relatively short. The minimum coordination distance  $d_{min}$  (see § 1.5.3) will provide adequate protection in these cases. The propagation mode (2) contour is therefore taken to be identical to a circle whose radius is the minimum coordination distance. Propagation mode (2) calculations are not required in these circumstances and the coordination area is determined using the propagation mode (1) procedure in § 2.2 only.

For an earth station operating with a non-geostationary space station using a non-directional antenna, a similar situation applies, and the low gain means that propagation mode (2) required distances will be less than the minimum coordination distance. Hence, for the case of a non-directional antenna the propagation mode (2) contour is also coincident with the circle of radius  $d_{min}$ , and the coordination area is determined using the propagation mode (1) procedures described in § 2.1.1 only.

For an earth station operating with a non-geostationary space station using a non-tracking directional antenna, the potential for interference arising from propagation mode (2) is the same as for an earth station operating with a geostationary space station. Hence, for the case of non-tracking directional antenna the coordination area is determined using both the propagation mode (1) and propagation mode (2) procedures described in § 2.1.

#### **1.4.3 Earth stations operating with both geostationary and non-geostationary space stations**

For earth stations that are sometimes intended to operate with geostationary space stations and at other times with non-geostationary space stations, separate coordination areas are determined for each type of operation. In such cases, the coordination area for the geostationary space station is determined using the procedures described in § 2.1 and the coordination area for the non-geostationary space station is determined using the procedure described in § 2.2. For each case, the percentage of time,  $p$ , is specified for all the operational time that the receiving earth station is expected to spend in reception from geostationary space stations or non-geostationary space stations, as appropriate.

#### **1.4.4 Earth stations operating in bidirectionally allocated frequency bands**

For earth stations operating in some frequency bands there may be allocations with equal rights to space services operating in both the Earth-to-space and space-to-Earth directions. In this case, where two earth stations are operating in opposite directions of transmission it is only necessary to establish the coordination area for the transmitting earth station, as receiving earth stations will automatically be taken into consideration. Hence, a receiving earth station operating in a bidirectionally allocated frequency band will only be involved in coordination with a transmitting earth station if it is located within the transmitting earth station's coordination area.

For a transmitting earth station operating with either geostationary or non-geostationary satellites in a bidirectionally allocated frequency band, the coordination area is determined using the procedures described in § 3. (WRC-03)

#### **1.4.5 Broadcasting-satellite service earth stations**

For earth stations in the broadcasting-satellite service operating in the unplanned bands, the coordination area is determined by extending the periphery of the specified service area within which the earth stations are operating by the coordination distance based on a typical BSS earth station. In calculating the coordination distance, no additional protection can be assumed to be available from the earth station horizon elevation angle, i.e.  $A_h = 0$  dB in Annex 1, for all azimuth angles around the earth station.

#### 1.4.6 Mobile (except aeronautical mobile) earth stations

For a mobile (except aeronautical mobile) earth station, the coordination area is determined by extending the periphery of the specified service area, within which the mobile (except aeronautical mobile) earth stations are operating, by the coordination distance. The coordination distance may be represented by a predetermined coordination distance (see Table 10), or it may be calculated. In calculating the coordination distance, no additional protection can be assumed to be available from the earth station horizon elevation angle, i.e.  $A_h = 0$  dB in Annex 1, for all azimuths around the earth station.

#### 1.4.7 Aeronautical mobile earth stations

For aeronautical mobile earth stations, the coordination area is determined by extending the periphery of the specified service area within which the aeronautical mobile earth station operates, by an appropriate predetermined coordination (see Table 10) distance for the respective services.

### 1.5 Propagation model concepts

For each mode of propagation, according to the requirements of the specific sharing scenario (see § 1.4) it is necessary to determine the predicted path loss. The determination of this predicted path loss is based on a number of propagation mechanisms.

Interference may arise through a range of propagation mechanisms whose individual dominance depends on climate, radio frequency, time percentage in question, distance and path topography. At any given point in time, one or more mechanisms may be present. The propagation mechanisms that are considered within this Appendix in the determination of the interference potential are as follows:

- *Diffraction*: Insofar as it relates to diffraction losses occurring over the earth station's local physical horizon. This effect is referred to below as "site shielding". The remainder of the path along each radial is considered to be flat and therefore free of additional diffraction losses.
- *Tropospheric scatter*: This mechanism defines the "background" interference level for paths longer than about 100 km, beyond which the diffraction field becomes very weak.
- *Surface ducting*: This is the most important short-term interference mechanism over water and in flat coastal land areas, and can give rise to high signal levels over greater distances, sometimes exceeding 500 km. Such signals can exceed the equivalent "free-space" level under certain conditions.
- *Elevated layer reflection and refraction*: The treatment of reflection and/or refraction from layers at heights of up to a few hundred metres is an important mechanism that enables signals to by-pass any diffraction losses due to the underlying terrain under favourable path geometry situations. Here again, the impact can be significant over long distances.

- *Hydrometeor scatter*: Hydrometeor scatter can be a potential source of interference between terrestrial station transmitters and earth stations because it may act isotropically, and can therefore have an impact irrespective of whether the common volume is on or off the great-circle interference path between the coordinating earth station and terrestrial stations, or other receiving earth stations operating in bidirectionally allocated frequency bands.

In this Appendix, propagation phenomena are classified into two modes as follows:

- *Propagation mode (1)*: propagation phenomena in clear air (tropospheric scatter, ducting, layer reflection/refraction, gaseous absorption and site shielding). These phenomena are confined to propagation along the great-circle path.
- *Propagation mode (2)*: hydrometeor scatter.

### 1.5.1 Propagation mode (1)

For the determination of the propagation mode (1) required distances, the applicable frequency range has been divided into three parts:

- For VHF/UHF frequencies between 100 MHz and 790 MHz and for time percentages from 1% to 50% of an average year.
- From 790 MHz to 60 GHz and for time percentages from 0.001% to 50% of an average year.
- From 60 GHz to 105 GHz and for time percentages from 0.001% to 50% of an average year.

The variation in predicted path loss due to the horizon elevation angle around an earth station is calculated by the method described in § 1 of Annex 1, using the horizon elevation angles and distances along different radials from the earth station. For all frequencies between 100 MHz and 105 GHz, the attenuation arising from the horizon characteristics is included in the value of propagation mode (1) predicted path loss, unless its use is specifically prohibited for a particular sharing scenario (see § 1.4.5 and § 1.4.6).

In the determination of the propagation mode (1) required distance, the world is divided into four basic radio-climatic zones. These zones are defined as follows:

- Zone A1: coastal land, i.e. land adjacent to a Zone B or a Zone C area (see below), up to an altitude of 100 m relative to mean sea or water level, but limited to a maximum distance of 50 km from the nearest Zone B or Zone C area; in the absence of precise information on the 100 m contour, an approximation (e.g. 300 feet) may be used. Large inland areas of at least 7 800 km<sup>2</sup> which contain many small lakes, or a river network, comprising more than 50% water, and where more than 90% of the land is less than 100 m above the mean water level may be included in Zone A1<sup>5</sup>.
- Zone A2: all land, other than coastal land as defined in Zone A1 above.

---

<sup>5</sup> These additional areas may be declared as coastal Zone A1 areas by administrations for inclusion in the ITU Digital World Map (IDWM).

- Zone B: “cold” seas, oceans and large bodies of inland water situated at latitudes above 30°, with the exception of the Mediterranean Sea and the Black Sea. A “large” body of inland water is defined, for the administrative purpose of coordination, as one having an area of at least 7 800 km<sup>2</sup>, but excluding the area of rivers. Islands within such bodies of water are to be included as water within the calculation of this area if they have elevations lower than 100 m above the mean water level for more than 90% of their area. Islands that do not meet these criteria should be classified as land for the purposes of calculating the area of the water.
- Zone C: “warm” seas, oceans and large bodies of inland water situated at latitudes below 30°, as well as the Mediterranean Sea and the Black Sea.

### 1.5.2 Propagation mode (2)

For the determination of the propagation mode (2) required distance, interference arising from hydrometeor scatter can be ignored at frequencies below 1 000 MHz and above 40.5 GHz outside the minimum coordination distance (see § 1.5.3.1). Below 1 000 MHz, the level of the scattered signal is very low and above 40.5 GHz, although significant scattering occurs, the scattered signal is then highly attenuated along the path from the scatter volume to the receiving terrestrial station or earth station. Site shielding is not relevant to propagation mode (2) mechanisms as the interference path is via the main beam of the coordinating earth station antenna.

### 1.5.3 Distance limits

The effect of interference on terrestrial and space systems often needs to be assessed by considering long- and short-term interference criteria. These criteria are generally represented by a permissible interference power not to be exceeded for more than a specified percentage of time.

The long-term interference criterion (typically associated with percentages of time  $\geq 20\%$ ) allows the error performance objective (for digital systems) or noise performance objective (for analogue systems) to be met. This criterion will generally represent a low level of interference and hence require a high degree of isolation between the coordinating earth station and terrestrial stations, or other receiving earth stations operating in bidirectionally allocated bands.

The short-term criterion is a higher level of interference, typically associated with time percentages in the range 0.001% to 1% of time, which will either make the interfered-with system unavailable, or cause its specified short-term interference objectives (error rate or noise) to be exceeded.

This Appendix addresses only the protection provided by the short-term criterion. There is therefore an implicit assumption that if the short-term criterion is satisfied, then any associated long-term criteria will also be satisfied. This assumption may not remain valid at short distances because additional propagation effects (diffraction, building/terrain scattering etc.) requiring a more detailed analysis become significant. A minimum coordination distance is therefore needed to avoid this difficulty. This minimum coordination distance is always the lowest value of coordination distance used. At distances equal to or greater than the minimum coordination distance, it can be assumed that interference due to continuous (long-term) propagation effects will not exceed levels permitted by the long-term criteria.

In addition to the minimum coordination distance, it is also necessary to set an upper limit to the calculation distance. Hence the coordination distance, on any azimuth, must lie within the range between the minimum coordination distance and the maximum calculation distance.

### 1.5.3.1 Minimum coordination distance

For the reasons stated in § 1.5.3, it is necessary to set a lower limit,  $d_{min}$ , for the coordination distance. The iterative calculation of the coordination distance starts at this minimum distance, and this distance varies according to radiometeorological factors and the frequency band (see § 4.2). This same minimum coordination distance applies both to propagation mode (1) and propagation mode (2) calculations.

### 1.5.3.2 Maximum calculation distance

Maximum calculation distances are required for propagation modes (1) and (2). In the case of mode (1), this distance corresponds to the maximum coordination distance,  $d_{max1}$ , given in § 4.3 for each of the four radioclimatic Zones. The propagation mode (1) maximum calculation distance is therefore dependent on the mixture of radioclimatic Zones in the propagation path, as described in § 4.3.

The maximum calculation distance for propagation mode (2) is given in § 2 of Annex 2.

## 1.6 The coordination contour: concepts and construction

The coordination distance, determined for each azimuth around the coordinating earth station, defines the coordination contour that encloses the coordination area. The coordination distance lies within the range defined by the minimum coordination distance and the maximum calculation distance.

In this Appendix, the procedures determine the distance at which the minimum required loss is equal to the predicted path loss. In addition, some procedures<sup>6</sup> require that, for any azimuth, the greater of the distances determined for propagation mode (1) and propagation mode (2) is the distance to be used in determining the coordination contour. In both these cases, the distance at which the minimum required loss is equal to the predicted path loss may or may not be within the range of valid values that define the limits for the coordination distance. Hence, the distance determined from the application of all the procedures is referred to as the required distance.

The coordination area is determined by one of the following methods:

- calculating, in all directions of azimuth from the earth station, the coordination distances and then drawing to scale on an appropriate map the coordination contour; or
- extending the service area in all directions by the calculated coordination distance(s); or
- for some services and frequency bands, extending the service area in all directions by a predetermined coordination distance.

Where a coordination contour includes the potential interference effects arising from both propagation mode (1) and propagation mode (2), the required distance used for any azimuth is the greater of the propagation mode (1) and propagation mode (2) required distances.

---

<sup>6</sup> The same procedures are also used to develop supplementary and auxiliary contours (see Annex 6).

The sharing scenarios and the various procedures contained in this Appendix are based on different assumptions. Hence, the coordination area developed for one sharing scenario is likely to be based on different sharing considerations, interference paths and operational constraints than the coordination area developed under a different sharing scenario. Separate coordination areas are therefore required for each sharing scenario described in § 1.4, and each coordination area is specific to the radiocommunication services covered by the sharing scenario under which it was developed. Further, the coordination area developed for one sharing scenario cannot be used to determine the extent of any impact on the radiocommunication services covered by a different sharing scenario. Thus, a coordinating earth station operating in a bidirectionally allocated frequency band that is also allocated to terrestrial services will have two separate coordination areas:

- one coordination area for determining those administrations with terrestrial services that may be affected by the operation of the coordinating earth station; and
- one coordination area for determining those administrations with receiving earth stations that may be affected by the operation of the coordinating (transmitting) earth station.

This means that the establishment of the coordination area for an earth station will generally require the determination of several individual coordination areas, each drawn on a separate map. For example, an earth station which transmits to a geostationary space station in the band 10.7-11.7 GHz will need to develop the following coordination areas with respect to:

- analogue terrestrial services which receive in the same band; this will comprise the potential effects arising from both propagation mode (1) and propagation mode (2) interference paths;
- an earth station operating with a geostationary space station which receives in the same band; this will comprise the potential effects arising from both propagation mode (1) and propagation mode (2) interference paths;
- an earth station operating with a non-geostationary space station which receives in the same band; this will comprise the potential effects arising from propagation mode (1) interference paths.

In addition, separate coordination contours are produced if the earth station both transmits and receives in bands shared with terrestrial services. However, for earth stations in bidirectionally allocated frequency bands, the coordination contours with respect to other earth stations are only produced for a transmitting earth station (see § 1.4.4).

Examples of coordination contours for each of the sharing scenarios in § 1.4 is provided in Fig. 1. It will be noticed that for some of the sharing scenarios there is a commonality to the construction of the coordination contour (shown by a solid line) that encompasses each coordination area. For those sharing scenarios where both propagation mode (1) and propagation mode (2) interference paths need to be taken into consideration, the parts of the propagation mode (1) contour and that part of the propagation mode (2) contour located within the overall coordination contour may be drawn using dashed lines.

FIGURE 1

Examples of coordination contours for each of the sharing scenarios listed in § 1.4

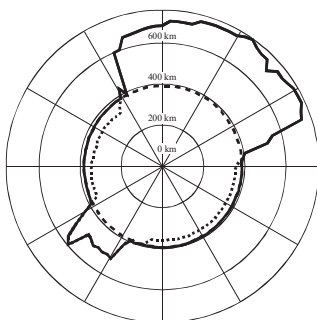

- a) Example of the coordination contour for an earth station operating with a GSO space station in § 1.4.1 and § 1.4.3. The coordination contour is marked by the outer line and is comprised of a propagation mode (1) contour and a circular propagation mode (2) contour. The propagation mode (1) contour could also be an example of an earth station with a non-tracking directional antenna operating with a non-GSO space station in § 1.4.2

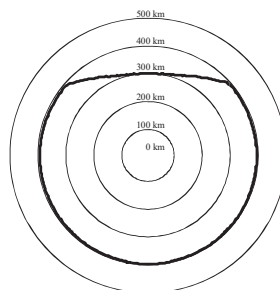

- b) Example of the coordination contour for an earth station with a tracking antenna operating with a non-GSO space station in § 1.4.2 and § 1.4.3

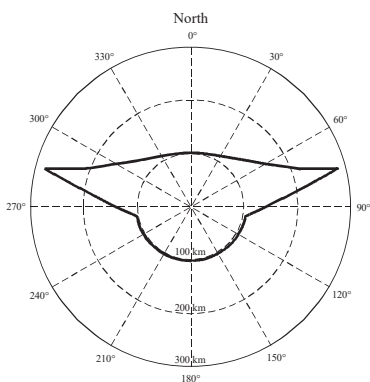

- c) Example of the coordination contour for an earth station operating in bidirectionally allocated frequency bands in § 1.4.4. The coordination contour has been developed from a propagation mode (1) contour for a coordinating earth station operating with a non-GSO space station with respect to unknown earth stations operating with GSO space stations. For a propagation mode (2) contour for the GSO-GSO case see Annex 5

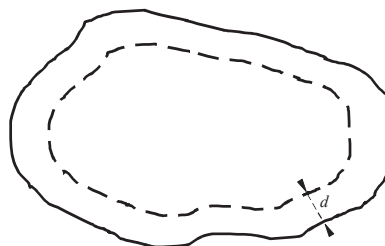

- d) Example of the coordination contour for an earth station operating in a specified service area in § 1.4.5, § 1.4.6 and § 1.4.7. The coordination contour is marked by the solid outer line and the specified service area by the broken inner line. The coordination distance,  $d$ , may be a constant value, or vary with azimuth, depending on the sharing scenario and the type of radiocommunication service

AP7-01



In addition to the coordination contour, supplementary contours and auxiliary contours (see Annex 6) may be drawn to facilitate more detailed sharing discussions. Supplementary contours are based on the coordinating earth station sharing frequency bands with other radiocommunication services, or other types of radio systems in the same service, that have less onerous sharing criteria than the radio system used for developing the coordination area. These supplementary contours may be developed by the same method used to determine the coordination contour, or by other methods as agreed on a bilateral basis between administrations. For example, the Time Variant Gain method described in § 4 of Annex 6 can be used to generate supplementary contours for earth stations operating with non-geostationary space stations. Auxiliary contours are based on less conservative assumptions, with regard to the interference path and operational constraints, for the unknown terrestrial stations, or earth stations. Auxiliary contours are developed separately for propagation mode (1) and propagation mode (2) interference paths. In this context, the contours from which the coordination contour was developed are called main contours, and the auxiliary contours for propagation mode (1) and propagation mode (2) are referenced to the appropriate main contour. The various assumptions used for developing auxiliary contours to the propagation mode (1) contour, or the propagation mode (2) contour, can also be applied to supplementary contours. Hence, auxiliary contours may be drawn for both a main or a supplementary contour.

Supplementary contours are always drawn on a separate map as they apply to other types of radio system within the same radiocommunication service, or to radio systems in different radiocommunication services. However, as auxiliary contours apply to the various assumptions used in developing the main, or supplementary, contour they are always drawn on the same map that contains the corresponding main, or supplementary, contour.

While the use of supplementary or auxiliary contours allows less conservative assumptions with regard to the interference path and operational constraints to be taken into consideration, earth stations may transmit or receive a variety of classes of emissions. Hence, the earth station parameters to be used in the determination of the coordination contour, and any supplementary or auxiliary contours, are those which lead to the greatest distances for each earth station antenna beam and each allocated frequency band which the coordinating earth station shares with other radiocommunication systems.

## **2 Determination of the earth station coordination area with respect to terrestrial stations**

This section contains the procedures for determining the coordination area for the case of earth stations sharing frequency bands with terrestrial stations. These procedures cover the cases for earth stations operating with space stations in the geostationary orbit, or in non-geostationary orbits, and are described in the following subsections.

For earth stations operating with space stations in non-geostationary orbits, consideration has to be given to the potential time-varying nature of the earth station's antenna gain towards the horizon.

## 2.1 Earth stations operating with geostationary space stations

For an earth station operating with a geostationary space station, the value of  $G_t$  and  $G_r$  towards the horizon is considered to be constant with time. The percentage of time associated with  $L_b$  in equation (1) is the same as the time percentage,  $p$ , associated with  $P_r(p)$ . When determining the coordination area between a coordinating earth station operating with a geostationary space station and terrestrial systems, the coordination distance on any azimuth is the greater of the propagation mode (1) and propagation mode (2) required distances. The required distances for propagation mode (1) and propagation mode (2) are determined using the procedures described in § 2.1.1 and § 2.1.2 respectively, after taking into consideration the following discussion on station-keeping.

When the north/south station-keeping of a geostationary space station is relaxed, the orbit of the space station becomes inclined with an inclination that increases gradually with time. This movement of the space station from its nominal position may require small corresponding adjustments in the elevation angle of the earth station antenna beam. Hence, to avoid considering the time variation in antenna gain in the direction of the horizon, the coordination area of an earth station operating with a space station in a slightly inclined geostationary orbit is determined for the minimum angle of elevation and the associated azimuth at which the space station is visible to the earth station (see Annex 3).

### 2.1.1 Determination of the coordinating earth station's propagation mode (1) contour

Determination of the propagation mode (1) contour is based on great circle propagation mechanisms and it is assumed, for the interference path, that all the terrestrial stations are pointing directly at the coordinating earth station's location. The required distance, on each azimuth, for propagation mode (1) is that distance which will result in a value of propagation mode (1) predicted path loss that is equal to the propagation mode (1) minimum required loss,  $L_b(p)$  (dB), as defined in § 1.3.

$$L_b(p) = P_t + G_e + G_x - P_r(p) \quad \text{dB} \quad (4)$$

where:

$P_t$  and  $P_r(p)$ : as defined in § 1.3

$G_e$ : gain of the coordinating earth station antenna (dBi) towards the horizon at the horizon elevation angle and azimuth under consideration

$G_x$ : maximum antenna gain (dBi) assumed for the terrestrial station. Tables 7 and 8 give values for  $G_x$  for the various frequency bands.

The propagation mode (1) required distance is determined using the procedures described in § 4, and the detailed methods in Annex 1. Specific guidance relevant to the application of the procedures is provided in § 4.4.

**2.1.2 Determination of the coordinating earth station’s propagation mode (2) contour**

The required distance for hydrometeor scatter is that distance that will result in a propagation mode (2) predicted path loss equal to the propagation mode (2) minimum required loss  $L(p)$ , as defined in equation (3). This propagation mode (2) required distance is determined using the guidance in § 5, and the detailed methods in Annex 2.

For an earth station operating with a geostationary space station having a slightly inclined orbit, the rain-scatter contours for each of the satellite’s two most extreme orbit positions are determined individually, using the relevant elevation angles and their associated azimuths to the satellite. The rain scatter area is the total area contained within the two resulting overlapping contours.

**2.2 Earth stations operating with non-geostationary space stations**

For an earth station that operates with non-geostationary space stations and whose antennas track the space stations, the antenna gain in the direction of the horizon on any azimuth varies with time. The method used to determine the coordination contour is the time invariant gain (TIG) method.

This method uses fixed values of antenna gain based on the maximum assumed variation in horizon antenna gain on each azimuth under consideration. In considering the horizon gain of the antenna for either a transmitting or a receiving earth station, only the horizon antenna gain values during the operational time are to be considered. The horizon antenna gain may be determined using Annex 4. Reference or measured antenna radiation patterns may be used as described in Annex 3. The values of horizon antenna gain defined below are used for each azimuth when applying equation (4) to determine the propagation mode (1) required distances:

$$\begin{aligned}
 G_e &= G_{max} && \text{for} && (G_{max} - G_{min}) \leq 20 \text{ dB} \\
 G_e &= G_{min} + 20 && \text{for} && 20 \text{ dB} < (G_{max} - G_{min}) < 30 \text{ dB} \\
 G_e &= G_{max} - 10 && \text{for} && (G_{max} - G_{min}) \geq 30 \text{ dB}
 \end{aligned}
 \tag{5}$$

where:

$G_e$ : gain of the coordinating earth station antenna (dBi) towards the horizon at the horizon elevation angle and azimuth under consideration in equation (4)

$G_{max}, G_{min}$ : maximum and minimum values of the horizon antenna gain (dBi), respectively, on the azimuth under consideration.

The maximum and minimum values of the horizon antenna gain, on the azimuth under consideration, are derived from the antenna pattern and the maximum and minimum angular separation of the antenna main beam axis from the direction of the physical horizon at the azimuth under consideration.

Where a single value of minimum elevation angle for the main beam axis of the earth station antenna is specified for all azimuths, the minimum and maximum values of the horizon gain can be determined, for each azimuth under consideration, from the antenna pattern and the horizon elevation angle at that azimuth. The plot of the horizon elevation angle against azimuth is called the horizon profile of the earth station.

Additional constraints may be included in the determination of the maximum and minimum values of the horizon antenna gain where an earth station is operating with a constellation of non-geostationary satellites at a latitude for which no satellite is visible at the earth station's specified minimum elevation angle over a range of azimuths. Over this range of azimuth angles, the minimum elevation angle of the earth station antenna main beam axis is given by the minimum elevation angle at which any satellite of the constellation is visible at that azimuth. The azimuthal dependence of this minimum satellite visibility elevation angle may be determined from consideration of the orbital altitude and inclination of the satellites in the constellation, without recourse to simulation, using the procedure in § 1.1 of Annex 4. In this case, the horizon antenna gain to be used in the method depends on the profile of the composite minimum elevation angle. This minimum composite elevation angle at any azimuth is the greater of the minimum satellite visibility elevation angle, at the azimuth under consideration, and the specified minimum elevation angle for the earth station which is independent of the azimuth.

Thus, at each azimuth under consideration, the maximum horizon antenna gain will be determined from the minimum value of the angular separation between the earth station horizon profile at this azimuth and the profile of the minimum composite elevation angle. Similarly, the minimum horizon antenna gain will be determined from the maximum value of the angular separation from the earth station horizon profile at this azimuth to the profile of the minimum composite elevation angle. The procedure for calculating the minimum and maximum angular separations from the profile of the minimum composite elevation angle is given in § 1.2 of Annex 4.

The propagation mode (1) required distance is then determined using the procedures described in § 4, and the detailed methods in Annex 1. Specific guidance relevant to the application of the propagation calculations is provided in § 4.4.

### **3 Determination of the coordination area between earth stations operating in bidirectionally allocated frequency bands**

This section describes the procedures to be used for determination of the coordination area for an earth station transmitting in a frequency band allocated to space services in both Earth-to-space and space-to-Earth directions.

There are various coordination scenarios, involving only non-time-varying antenna gains, or only time-varying antenna gains (both earth stations operate with non-geostationary space stations) or, one time-varying antenna gain and one non-time-varying antenna gain.

The following subsections describe the methods for the determination of coordination area which are specific to each of these bidirectional cases. The procedures applicable to the coordination scenario where both earth stations operate with geostationary space stations are given in § 3.1. The other bidirectional coordination scenarios are considered in § 3.2, where particular attention is given to the approaches for using the horizon antenna gain of the receiving earth station for each of the possible coordination scenarios in the appropriate procedure of § 2.

Table 9 provides the parameters that are to be used in the determination of the coordination area. Table 9 also indicates whether, in each band, the receiving earth stations operate with geostationary or non-geostationary space stations. In some bands, receiving earth stations may operate with both geostationary and non-geostationary space stations. Table 2 indicates the number of coordination contours which need to be drawn for each coordination scenario and the section(s) containing the applicable calculation methods. Once drawn, each coordination contour must be appropriately labelled.

TABLE 2

Coordination contours required for each bidirectional scenario

Coordinating earth station operating to a space station in the	Unknown receiving earth station operating with a space station in the	Section containing the method to determine $G_f$ and $G_r$	Contours required	
			No.	Details
Geostationary orbit	Geostationary orbit	§ 3.1	1	A coordination contour comprising both propagation mode (1) and propagation mode (2) contours
	Non-geostationary orbit	§ 3.2.1	1	A propagation mode (1) coordination contour
	Geostationary or non-geostationary orbits <sup>1</sup>	§ 3.1 and 3.2.1	2	Two separate coordination contours, one for the geostationary orbit (propagation mode (1) and mode (2) contours) and one for the non-geostationary orbit (propagation mode (1) contour)
Non-geostationary orbit	Geostationary orbit	§ 3.2.2	1	A propagation mode (1) coordination contour
	Non-geostationary orbit	§ 3.2.3	1	A propagation mode (1) coordination contour
	Geostationary or non-geostationary orbits <sup>1</sup>	§ 3.2.2 and 3.2.3	2	Two separate propagation mode (1) coordination contours, one for the geostationary orbit and one for the non-geostationary orbit

<sup>1</sup> In this case, the bidirectional frequency band may contain allocations in the space-to-Earth direction for space stations in both the geostationary orbit and non-geostationary orbits. Hence, the coordinating administration will not know whether the unknown receiving earth stations are operating with space stations in the geostationary orbit or non-geostationary orbit.

### 3.1 Coordination of known and unknown earth stations operating with geostationary space stations

When both the known and the unknown earth stations operate with space stations in the geostationary orbit, it is necessary to develop a coordination contour comprising both propagation mode (1) and propagation mode (2) contours, using the procedures described in § 3.1.1 and 3.1.2, respectively.

### 3.1.1 Determination of the coordinating earth station's propagation mode (1) contour

The procedure for the determination of the propagation mode (1) contour in this case differs from that described in § 2.1.1 in two ways. First, the parameters to be used for the unknown receiving earth station are those in Table 9. Second, and more significantly, the knowledge that the unknown earth stations operate with geostationary satellites can be used to calculate the worst-case value of the horizon antenna gain of the receiving earth station towards the transmitting earth station for each azimuth at the transmitting earth station. The propagation mode (1) required distance is that distance which will result in a value of propagation mode (1) predicted path loss which is equal to the propagation mode (1) minimum required loss,  $L_b(p)$  (dB), as defined in § 1.3, and repeated here for convenience.

$$L_b(p) = P_t + G_t + G_r - P_r(p) \quad \text{dB} \quad (6)$$

where:

$P_t$  and  $P_r(p)$ : as defined in § 1.3

$G_t$ : gain of the coordinating (transmitting) earth station antenna (dBi) towards the horizon at the horizon elevation angle and the azimuth under consideration

$G_r$ : the horizon antenna gain of the unknown receiving earth station towards the transmitting earth station on the specific azimuth from the coordinating earth station. Values are determined by the procedure in § 2.1 of Annex 5, based on parameters from Table 9.

To facilitate the determination of the values of  $G_r$  to be used at an azimuth from the transmitting earth station, several simplifying approximations must be made:

- that the horizon elevation of the receiving earth station is zero degrees on all azimuths;
- that the receiving earth station operates with a space station that has zero degrees orbital inclination and may be located anywhere on the geostationary orbit that is above the minimum elevation angle, given in Table 9, for the location of the receiving earth station;
- that the latitude of the receiving earth station is the same as that of the transmitting earth station;
- that plane geometry can be used to interrelate the azimuth angles at the respective earth stations, rather than using the great circle path.

The first three assumptions provide the basis for determining the horizon antenna gain of the receiving earth station on any azimuth. The assumption of  $0^\circ$  horizon elevation angle is conservative since the increase in horizon antenna gain due to a raised horizon would, in practice, be more than offset by any real site shielding<sup>7</sup>. The last two assumptions in the list simplify the calculation of the sum of  $G_t$  and  $G_r$  along any azimuth. Since the propagation mode (1) required distances are small, in global geometric terms these approximations may introduce a small error in the determination of the horizon antenna gain of the receiving earth station antenna that, in any case, will not exceed 2 dB. Because of

---

<sup>7</sup> While no site shielding can be assumed for the receiving earth station, any site shielding that may exist at the transmitting earth station is considered by taking into account the horizon elevation angle in accordance with § 1 of Annex 1.

the assumption of plane geometry, for a given azimuth at the transmitting earth station the appropriate value of the horizon antenna gain of the receiving earth station is the value on the reciprocal (i.e.  $\pm 180^\circ$ , see § 2.1 of Annex 5) azimuth at the receiving earth station.

The propagation mode (1) required distance is then determined using the procedures described in § 4, and the detailed methods in Annex 1. Specific guidance relevant to the application of the propagation calculations is provided in § 4.4.

### **3.1.2 Determination of the coordinating earth station's propagation mode (2) contour**

The procedure for the determination of the propagation mode (2) contour for a transmitting earth station operating with a geostationary space station uses the same simplifying approximations as made in § 3.1.1, but it is based on a geometrical construction that avoids the requirement for a complex propagation model (see § 3 of Annex 5). Auxiliary contours cannot be used in this method, as the calculations are not based on the propagation mode (2) required loss.

The propagation mode (2) contour is determined using the elevation angle and the azimuth from the coordinating transmitting earth station to the space station, together with the following two considerations:

- the minimum coordination distance (see § 4.2), which will be the required distance for some azimuths; and
- a worst-case required distance determined by the hydrometeor scatter geometry for a receiving earth station located in either of two  $6^\circ$  azimuth sectors. Within these sectors, the receiving earth station is assumed to be operating at the minimum elevation angle to a space station in the geostationary orbit and its main beam intersects the beam for the coordinating transmitting earth station at the point where the latter beam passes through the rain height,  $h_R$ . Although the scattering can occur anywhere between the coordinating earth station and this point, the intersection of the two beams at this point represents the worst-case interference scenario. Hence, it results in the worst-case distance requirement for receiving earth stations located in the two azimuth sectors.

For an earth station operating with a space station in an inclined orbit, the lowest expected operational antenna elevation angle and its associated azimuth are used in the calculations.

The propagation mode (2) contour is determined using the method in § 3 of Annex 5.

### **3.2 Coordinating or unknown earth stations operating with non-geostationary space stations**

To determine the coordination area, the method described in § 2.2 is used. For the cases where a coordinating (transmitting) earth station operates with non-geostationary space stations, the following procedures assume that the earth station antenna is tracking the space station, otherwise see § 1.4.2. Table 9 provides values of horizon antenna gain to be used in the calculations.

One or more of the following three procedures may be needed to determine the required propagation mode (1) coordination contours of Table 2. Propagation mode (2) contours are not required for any of the cases where either of the earth stations operates with space stations in non-geostationary orbits.

### **3.2.1 A coordinating earth station operating with a geostationary space station with respect to unknown earth stations operating with non-geostationary space stations**

When the coordinating earth station operates with a space station in the geostationary orbit and the unknown earth stations operate with space stations in non-geostationary orbits, the propagation mode (1) coordination area is determined using the procedures described in § 2.1.1. The only modification needed is to use the horizon antenna gain,  $G_r$ , of the unknown receiving earth station in place of the terrestrial station gain,  $G_x$ . The appropriate values for this gain and the appropriate system parameters are contained in Table 9.

### **3.2.2 A coordinating earth station operating with non-geostationary space stations with respect to unknown earth stations operating with geostationary space stations**

When the coordinating earth station operates to space stations in non-geostationary orbits and the unknown earth stations operate with space stations in the geostationary orbit, the horizon antenna gain,  $G_r$ , for the unknown receiving earth station is determined in accordance with the simplifying approximations of § 3.1.1, as elaborated in § 2.1 of Annex 5, and the parameters of Table 9. Determination of the propagation mode (1) coordination area then follows the procedure of § 2.2 by using the appropriate horizon gain of the receiving earth station at each azimuth under consideration and the appropriate system parameters from Table 9.

### **3.2.3 Coordinating and unknown earth stations operating with non-geostationary space stations**

When the coordinating earth station operates with space stations in non-geostationary orbits and the unknown earth stations operate with space stations in non-geostationary orbits, the propagation mode (1) coordination area is determined using the procedure described in § 2.2. The only modification is to use the horizon antenna gain,  $G_r$ , of the unknown receiving earth station in place of the terrestrial station antenna gain. The appropriate values for this gain and the appropriate system parameters are given in Table 9.

## **4 General considerations for the determination of the propagation mode (1) required distance**

For the determination of the propagation mode (1) required distances, the applicable frequency range has been divided into three parts. The propagation calculations for the VHF/UHF frequencies between 100 MHz and 790 MHz are based upon propagation mode (1) predicted path loss curves. From 790 MHz to 60 GHz the propagation modelling uses tropospheric scatter, ducting and layer reflection/refraction models. At higher frequencies up to 105 GHz, the model is based on a free-space loss and a conservative assumption for gaseous absorption. The possible range of time percentages is different in the different propagation models.



After taking site shielding (see § 1 of Annex 1) into consideration, for the coordinating earth station only, the following methods are used to determine the propagation mode (1) required distances:

- For frequencies between 100 MHz and 790 MHz, the method described in § 2 of Annex 1.
- For frequencies between 790 MHz and 60 GHz, the method described in § 3 of Annex 1.
- For frequencies between 60 GHz and 105 GHz, the method described in § 4 of Annex 1.

The three methods referred to above rely on a value of propagation mode (1) minimum required loss, determined according to the appropriate system parameters in Tables 7, 8 and 9.

**4.1 Radio-climatic information**

For the calculation of the propagation mode (1) required distance, the world has been classified in terms of a radio-meteorological parameter representing clear-air anomalous propagation conditions. The percentage of time  $\beta_e$  for which these clear-air anomalous propagation conditions exist, is latitude dependent and is given by:

$$\beta_e = \begin{cases} 10^{1.67-0.015 \zeta_r} & \text{for } \zeta_r \leq 70^\circ & (7) \\ 4.17 & \text{for } \zeta_r > 70^\circ & (8) \end{cases}$$

with:

$$\zeta_r = \begin{cases} |\zeta| - 1.8 & \text{for } |\zeta| > 1.8^\circ & (9) \\ 0 & \text{for } |\zeta| \leq 1.8^\circ & (10) \end{cases}$$

where  $\zeta$  is the latitude of the earth station’s location (degrees).

For frequencies between 790 MHz and 60 GHz, the path centre sea level surface refractivity,  $N_0$ , is used in the propagation mode (1) calculations. This can be calculated using:

$$N_0 = 330 + 62.6 e^{-\left(\frac{\zeta-2}{32.7}\right)^2} \tag{11}$$

**4.2 Minimum coordination distance for propagation modes (1) and (2)**

The minimum coordination distance can be calculated in two steps. First calculate distance  $d_x$  using:

$$d_x = 100 + \frac{(\beta_e - 40)}{2} \quad \text{km} \tag{12}$$

where  $\beta_e$  is given in § 4.1.

Then calculate the minimum coordination distance at any frequency,  $f$  (GHz) in the range 100 MHz to 105 GHz using:

$$d_{min} = \begin{cases} 100 + \frac{(\beta_e - f)}{2} & \text{km} & \text{for } f < 40 \text{ GHz} & (13) \\ \frac{(54 - f)d_x + 10(f - 40)}{14} & \text{km} & \text{for } 40 \text{ GHz} \leq f < 54 \text{ GHz} & (14) \\ 10 & \text{km} & \text{for } 54 \text{ GHz} \leq f < 66 \text{ GHz} & (15) \\ \frac{10(75 - f) + 45(f - 66)}{9} & \text{km} & \text{for } 66 \text{ GHz} \leq f < 75 \text{ GHz} & (16) \\ 45 & \text{km} & \text{for } 75 \text{ GHz} \leq f < 90 \text{ GHz} & (17) \\ 45 - \frac{(f - 90)}{1.5} & \text{km} & \text{for } 90 \text{ GHz} \leq f \leq 105 \text{ GHz} & (18) \end{cases}$$

The distance from which all iterative calculations start (for both propagation mode (1) and propagation mode (2)), is the minimum coordination distance,  $d_{min}$ , as given in equations (13) to (18).

### 4.3 Maximum coordination distance for propagation mode (1)

In the iterative calculation described in Annex 1, it is necessary to set an upper limit,  $d_{max1}$ , to the propagation mode (1) coordination distance.

For frequencies less than or equal to 60 GHz and propagation paths entirely within a single Zone, the distance shall not exceed the maximum coordination distance given in Table 3 for that Zone.

For mixed paths, the required distance can comprise one or more contributions from Zones A1, A2, B and C. The aggregate distance for any one zone must not exceed the value given in Table 3. The overall required distance must not exceed the value in Table 3 for the zone in the mixed path having the largest Table 3 value. Thus, a path comprising both Zones A1 and A2 must not exceed 500 km.

TABLE 3

Maximum coordination distances for propagation mode (1) for frequencies below 60 GHz

Zone	$d_{max1}$ (km)
A1	500
A2	375
B	900
C	1 200

For frequencies above 60 GHz, the maximum coordination distance,  $d_{max1}$ , is given by:

$$d_{max1} = 80 - 10 \log \left( \frac{p}{50} \right) \tag{19}$$

where  $p$  is defined in § 1.3.

**4.4 Guidance on application of propagation mode (1) procedures**

As explained in § 1.3, for those cases where earth stations are sharing with terrestrial stations, it is appropriate to apply a correction factor,  $C_i$  (dB), to the worst-case assumptions on system parameters and interference path geometry. This correction factor takes into account the fact that the assumption that all the worst-case values will occur simultaneously is unrealistic when determining the propagation mode (1) required distances.

The characteristics of terrestrial systems depend on the frequency band, and the value of the correction factor to be applied follows the frequency dependence given in equation (20). At frequencies between 100 MHz and 400 MHz, and between 60 GHz and 105 GHz, sharing between earth stations and terrestrial systems is a recent development and there is little established practical experience, or opportunity to analyse operational systems. Hence, the value of the correction factor is 0 dB in these bands. Between 400 MHz and 790 MHz and between 4.2 GHz and 60 GHz, the value of the correction factor is reduced in proportion to the logarithm of the frequency, as indicated in equation (20).

The value of the nominal correction to be used at any frequency  $f$ (GHz) is therefore given by:

$$X(f) = \begin{cases} 0 & \text{dB for } f \leq 0.4 \text{ GHz} \\ 3.3833X(\log f + 0.3979) & \text{dB for } 0.4 \text{ GHz} < f \leq 0.79 \text{ GHz} \\ X & \text{dB for } 0.79 \text{ GHz} < f \leq 4.2 \text{ GHz} \\ -0.8659X(\log f - 1.7781) & \text{dB for } 4.2 \text{ GHz} < f \leq 60 \text{ GHz} \\ 0 & \text{dB for } f > 60 \text{ GHz} \end{cases} \tag{20}$$

where:

$X$ : 15 dB for a transmitting earth station and 25 dB for a receiving earth station.

In principle, the value of the nominal correction factor,  $X(f)$ , is distance and path independent. However, there are a number of issues relating to interference potential at the shorter distances, and it is not appropriate to apply the full nominal correction at these distances. The correction factor  $C_i$  is therefore applied proportionally with distance along the azimuth under consideration, starting with 0 dB at  $d_{min}$ , such that the full value of  $X(f)$  is achieved at a nominal distance of 375 km from the earth station.

Hence, the correction is applied using the correction constant  $Z(f)$  (dB/km) where:

$$Z(f) = \frac{X(f)}{375 - d_{min}} \quad \text{dB/km} \tag{21}$$

The correction factor  $C_i$  (dB) is calculated in equations (28b) and (52) from the correction constant  $Z(f)$  (dB/km).

At distances greater than 375 km, the correction factor  $C_i$  to be applied is the value of  $C_i$  at 375 km distance.

In addition, the correction factor is applied to its highest value only on land paths. The correction factor is 0 dB for wholly sea paths. A proportion of the correction factor is applied on mixed paths. The amount of correction to be applied to a particular path is determined by the path description parameters used for the propagation mode (1) calculation (correction factors  $C_i$  and  $C_{2i}$  in § 2 and § 3 respectively of Annex 1). As the correction factor is distance dependent, it is applied automatically within the iterative calculation used to determine the propagation mode (1) required distance (see Annex 1).

The correction factor does not apply to the bidirectional case and therefore in the determination of the bidirectional coordination contour:

$$Z(f) = 0 \quad \text{dB/km}$$

For the determination of propagation mode (1) auxiliary contours, the propagation mode (1) minimum required loss  $L_b(p)$  for  $p\%$  of time in equation (1) (see § 1.3) is replaced by:

$$L_{bq}(p) = L_b(p) + Q \quad \text{dB} \quad (22)$$

where:

$Q$ : auxiliary contour value (dB).

Note that auxiliary contour values are assumed to be negative (i.e. -5, -10, -15, -20 dB, etc.).

## 5 General considerations for the determination of the propagation mode (2) required distance

The determination of the contour for scattering from hydrometeors (e.g. rain scatter) is predicted on a path geometry that is substantially different from that of the great-circle propagation mechanisms. Hydrometeor scatter can occur where the beams of the earth station and the terrestrial station intersect (partially or completely) at, or below, the rain height  $h_R$  (see § 3 of Annex 2). It is assumed that at heights above this rain height the effect of scattering will be suppressed by additional attenuation, and it will not, therefore, contribute significantly to the interference potential. For the determination of the propagation mode (2) contour, it is assumed that the main beam of any terrestrial station exactly intersects the main beam of the coordinating earth station. The mitigating effects of partial beam intersections can be determined using propagation mode (2) auxiliary contours.

Since, to a first approximation, microwave energy is scattered isotropically by rain, interference can be considered to propagate equally at all azimuths around the common volume centred at the beam intersection (see § 1.3). Generally, the beam intersection will not lie on the great-circle path between the two stations. A common volume can therefore result from terrestrial stations located anywhere around the earth station, including locations behind the earth station.

The propagation mode (2) contour is a circle with a radius equal to the propagation mode (2) required distance. Unlike the case for propagation mode (1), the propagation mode (2) contour is not centred on the earth station's physical location, instead it is centred on a point on the earth's surface immediately below the centre of the common volume.

A common volume can exist, with equal probability, at any point along the earth station beam between the earth station's location and the point at which the beam reaches the rain height. To provide appropriate protection for/from terrestrial stations<sup>8</sup>, the centre of the common volume is assumed to be half way between the earth station and the point at which its beam intersects the rain height. The distance between the projection of this point on to the Earth's surface and the location of the earth station is known as  $\Delta d$  (see § 4 of Annex 2). The centre of the propagation mode (2) contour is therefore  $\Delta d$  (km) from the earth station on the azimuth of the earth station's main beam axis.

### 5.1 The required distance for propagation mode (2)

Propagation mode (2) required distances are measured along a radial originating at the centre of the rain scatter common volume. The calculation requires iteration for distance, starting at the same minimum distance as that defined for propagation mode (1) until either the required propagation mode (2) minimum required loss, or a latitude-dependent propagation mode (2) maximum calculation distance, is achieved. The propagation mode (2) calculations use the method described in Annex 2. The calculations only need to be performed in the frequency range 1 000 MHz to 40.5 GHz. Outside this frequency range, rain scatter interference can be neglected and the propagation mode (2) required distance is set to the minimum coordination distance given by equations (13) to (18).

## ANNEX 1

### Determination of the required distance for propagation mode (1)

#### 1 Adjustments for earth station horizon elevation angle and distance

For propagation mode (1), the required distance depends on the characteristics of the physical horizon around the earth station. The horizon is characterized by the horizon distance  $d_h$  (see below), and the horizon elevation angle  $\epsilon_h$ . The horizon elevation angle is defined here as the angle (degrees), viewed from the centre of the earth station antenna, between the horizontal plane and a ray that grazes the physical horizon in the direction concerned. The value of  $\epsilon_h$  is positive when the physical horizon is above the horizontal plane and negative when it is below.

It is necessary to determine horizon elevation angles and distances for all azimuths around an earth station. In practice it will generally suffice to do this in azimuth increments of 5°. However, every attempt should be made to identify, and take into consideration, minimum horizon elevation angles that may occur between those azimuths examined in 5° increments.

---

<sup>8</sup> This procedure does not apply for the case of an earth station sharing a frequency band with other earth stations operating in the opposite direction of transmission, as for that specific case the propagation mode (2) contour is based on a geometric construction.

For the purposes of the determination of the propagation mode (1) required distance it is useful to separate the propagation effects related to the local horizon around the earth station which, on some or all azimuths, may be determined by nearby hills or mountains, from the propagation effects on the remainder of the path. This is achieved by referencing the propagation model to a 0° horizon elevation angle for the coordinating earth station, and then to include a specific term  $A_h$  to deal with the known horizon characteristics of the earth station being coordinated. Where appropriate,  $A_h$  modifies the value of the path loss, on each azimuth, from which the propagation mode (1) required distance is derived.

There are two situations in which the level of attenuation for the propagation mode (1) path loss with respect to the reference 0° case can change:

- The first is where the coordinating earth station has a positive horizon elevation angle (on a particular azimuth). In this case, it will benefit from additional diffraction propagation losses over the horizon (generally referred to as site shielding). As a result, the attenuation  $A_h$  is positive and the value of the required path loss is reduced, with respect to the reference 0° horizon elevation angle case (see equations (27a) and (27b)).
- The second situation is where the coordinating earth station is at a location above the local foreground, and has a negative (downward) horizon elevation angle on a particular azimuth. In this case, a measure of additional protection is necessary because the path angular distance along the radial is reduced and hence the path loss for a given distance will be lower than for the zero degree elevation angle case. It is convenient to deal with this effect as part of the site shielding calculation. As a result, the attenuation  $A_h$  will be negative and the value of the required path loss is increased, with respect to the reference 0° horizon elevation angle case.

The contribution made by the attenuation arising from the coordinating earth station’s horizon characteristics to the propagation mode (1) minimum required loss modifies the value of path loss that then needs to be determined in the three propagation mode (1) models. The attenuation  $A_h$  is calculated for each azimuth around the coordinating earth station as follows.

The distance of the horizon,  $d_h$ , from the earth station’s location, is determined by:

$$d_h = \begin{cases} 0.5 \text{ km} & \text{if no information is available about the horizon distance, or} \\ & \text{if the distance is } < 0.5 \text{ km} \\ \text{horizon distance (km)} & \text{if this is within the range } 0.5 \text{ km} \leq \text{horizon distance} \leq 5.0 \text{ km} \\ 5.0 \text{ km} & \text{if the horizon distance is } > 5.0 \text{ km} \end{cases}$$

The contribution made by the horizon distance,  $d_h$ , to the total site shielding attenuation is given by  $A_d$  (dB) for each azimuth using:

$$A_d = 15 \left[ 1 - \exp\left(\frac{0.5 - d_h}{5}\right) \right] \left[ 1 - \exp\left(-\epsilon_h f^{1/3}\right) \right] \quad \text{dB} \quad (23)$$

where  $f$  is the frequency (GHz) throughout this Annex.

The total site shielding attenuation along each azimuth from the coordinating earth station is given by:

$$A_h = \begin{cases} 20 \log (1 + 4.5\varepsilon_h f^{1/2}) + \varepsilon_h f^{1/3} + A_d & \text{dB for } \varepsilon_h \geq 0^\circ & (24a) \\ 3 \left[ (f+1)^{1/2} - 0.0001 f - 1.0487 \right] \varepsilon_h & \text{dB for } 0^\circ > \varepsilon_h \geq -0.5^\circ & (24b) \\ -1.5 \left[ (f+1)^{1/2} - 0.0001 f - 1.0487 \right] & \text{dB for } \varepsilon_h < -0.5^\circ & (24c) \end{cases}$$

The value of  $A_h$  must be limited to satisfy the conditions:

$$-10 \leq A_h \leq (30 + \varepsilon_h) \quad (25)$$

In equations (23), (24) and (25) the value of  $\varepsilon_h$  must always be expressed in degrees. The limits defined in equation (25) are specified because protection outside these limits may not be realized in practical situations.

## 2 Frequencies between 100 MHz and 790 MHz

The propagation model given in this section is limited to an average annual time percentage,  $p$ , in the range 1% to 50%.

An iterative process is used to determine the propagation mode (1) required distance. First, equation (27) is evaluated. Then, commencing at the minimum coordination distance,  $d_{min}$ , given by the method described in § 1.5.3 of the main body of this Appendix, equations (28) to (31) are iterated for distances  $d_i$  (where  $i = 0, 1, 2, \dots$ ) incremented in steps of  $s$  (km) as described in § 1.3 of the main body of this Appendix. In each iteration,  $d_i$  is the distance considered. This process is continued until either of the following expressions becomes true:

$$L_2(p) \geq \begin{cases} L_1(p) & \text{for the main or supplementary contour} \\ L_{1q}(p) & \text{for the auxiliary contour} \end{cases} \quad (26a)$$

or:

$$d_i \geq \begin{cases} d_{max1} & \text{for the main or supplementary contour} \\ d_1 & \text{for the auxiliary contour} \end{cases} \quad (26b)$$

The required distance,  $d_1$ , or the auxiliary contour distance,  $d_q$ , are then given by the distance for the last iteration: i.e.

$$d_1 = d_i \quad (26c)$$

or:

$$d_q = d_i \quad (26d)$$

As the eventual mix of zones along a path is unknown, all paths are treated as if they are potential land and sea paths. Parallel calculations are undertaken, the first assuming the path is all land and a second assuming it is all sea. A non-linear interpolation is then performed, the output of which depends upon the current mix of land and sea losses in the distance,  $d_i$ . Where the current mix along the path includes sections of both warm sea and cold sea zones, all the sea along that path is assumed to be warm sea.

For the main or supplementary contour:

$$L_1(p) = L_b(p) - A_h \quad (27a)$$

For an auxiliary contour:

$$L_{1q}(p) = L_{bq}(p) - A_h \quad (27b)$$

where:

$L_b(p)$  (dB) and  $L_{bq}(p)$  (dB): minimum required loss required for  $p\%$  of the time for the main or supplementary contour and the auxiliary contour with value  $Q$  (dB), respectively (see equation (22)).

### Iterative calculations

At the start of each iteration calculate the current distance for  $i = 0, 1, 2, \dots$ :

$$d_i = d_{min} + i \cdot s \quad (28a)$$

The correction factor,  $C_i$  (dB), (see § 4.4 of the main body of this Appendix) for the distance,  $d_i$ , is given by:

$$C_i = \begin{cases} Z(f)(d_i - d_{min}) & \text{dB} & \text{for the main or supplementary contour} \\ 0 & \text{dB} & \text{for the auxiliary contour} \end{cases} \quad (28b)$$

where  $Z(f)$  is given by equation (21) in § 4.4 of the main body of this Appendix.

At distances greater than 375 km, the value of the correction factor ( $C_i$  in equation (28b)) to be applied is the value of  $C_i$  at the 375 km distance.

The loss,  $L_{bl}(p)$ , where it is assumed that the path is wholly land (Zones A1 or A2), is evaluated successively using:

$$L_{bl}(p) = 142.8 + 20 \log f + 10 \log p + 0.1 d_i + C_i \quad (29)$$

The loss,  $L_{bs}(p)$ , where it is assumed that the path is wholly cold sea (Zone B) or warm sea (Zone C), is evaluated successively using:

$$L_{bs}(p) = \begin{cases} \left. \begin{aligned} &49.91 \log(d_i + 1840 f^{1.76}) + 1.195 f^{0.393} (\log p)^{1.38} d_i^{0.597} \\ &+ (0.01 d_i - 70)(f - 0.1581) + (0.02 - 2 \times 10^{-5} p^2) d_i \end{aligned} \right\} \text{for Zone B} \quad (30a) \\ + 9.72 \times 10^{-9} d_i^2 p^2 + 20.2 \end{cases}$$

$$\left. \begin{aligned} &49.343 \log(d_i + 1840 f^{1.58}) + 1.266 (\log p)^{(0.468 + 2.598 f)} d_i^{0.453} \\ &+ (0.037 d_i - 70)(f - 0.1581) + 1.95 \times 10^{-10} d_i^2 p^3 + 20.2 \end{aligned} \right\} \text{for Zone C} \quad (30b)$$

The predicted path loss at the distance considered is then given by:

$$L_2(p) = L_{bs}(p) + \left[ 1 - \exp \left( -5.5 \left( \frac{d_{lm}}{d_i} \right)^{1.1} \right) \right] (L_{bl}(p) - L_{bs}(p)) \quad (31)$$

where:

$d_{lm}$  (km): longest continuous land (inland + coastal) distance, i.e. Zone A1 + Zone A2 along the current path.



### 3 Frequencies between 790 MHz and 60 GHz

The propagation model given in this section is limited to an average annual time percentage ( $p$ ) in the range 0.001% to 50%.

An iterative process is used to determine the propagation mode (1) required distance. First, equations (33) to (42) are evaluated. Then, commencing at the minimum coordination distance,  $d_{min}$ , equations (43) to (53) are iterated for distances  $d_i$ , where  $i = 0, 1, 2, \dots$ , incremented in steps of  $s$  (km) as described in § 1.3 of the main body of this Appendix. For each iteration,  $d_i$  is the distance considered. This process is continued until either of the following expressions becomes true:

$$\begin{aligned} (L_5(p) \geq L_3(p)) \quad \text{and} \quad (L_6(p) \geq L_4(p)) \quad \text{for the main or supplementary contour} \\ (L_5(p) \geq L_{3q}(p)) \quad \text{and} \quad (L_6(p) \geq L_{4q}(p)) \quad \text{for the auxiliary contour} \end{aligned} \quad (32a)$$

or:

$$d_i \geq \begin{cases} d_{max1} & \text{for the main or supplementary contour} \\ d_1 & \text{for the auxiliary contour} \end{cases} \quad (32b)$$

The required distance,  $d_1$ , or the auxiliary contour distance,  $d_q$ , is then given by the current distance for the last iteration, i.e.:

$$d_1 = d_i \quad (32c)$$

or:

$$d_q = d_i \quad (32d)$$

#### Specific attenuation due to gaseous absorption

Calculate the specific attenuation (dB/km) due to dry air:

$$\gamma_o = \begin{cases} \left[ 7.19 \times 10^{-3} + \frac{6.09}{f^2 + 0.227} + \frac{4.81}{(f-57)^2 + 1.50} \right] f^2 \times 10^{-3} & \text{for } f \leq 56.77 \text{ GHz} \\ 10 & \text{for } f > 56.77 \text{ GHz} \end{cases} \quad (33a)$$

$$\quad \quad \quad (33b)$$

The specific attenuation due to water vapour is given as a function of  $\rho$  (the water vapour density ( $\text{g/m}^3$ )) by the following equation:

$$\gamma_w(\rho) = \left( 0.050 + 0.0021\rho + \frac{3.6}{(f-22.2)^2 + 8.5} \right) f^2 \rho \times 10^{-4} \quad (34)$$

Calculate the specific attenuation (dB/km) due to water vapour for the troposcatter propagation model using a water vapour density of 3.0  $\text{g/m}^3$ :

$$\gamma_{wt} = \gamma_w(3.0) \quad (35a)$$

Calculate the specific attenuation (dB/km) due to water vapour for the ducting propagation model using a water vapour density of 7.5  $\text{g/m}^3$  for paths over land, Zones A1 and A2, using:

$$\gamma_{wdl} = \gamma_w(7.5) \quad (35b)$$

Calculate the specific attenuation (dB/km) due to water vapour for the ducting propagation model using a water vapour density of  $10.0 \text{ g/m}^3$  for paths over sea, Zones B and C, using:

$$\gamma_{wds} = \gamma_w (10.0) \quad (35c)$$

Note that the value of  $10 \text{ g/m}^3$  is used for both Zones B and C in view of the lack of data on the variability of water vapour density on a global basis, particularly the minimum values.

Calculate the frequency-dependent ducting specific attenuation (dB/km):

$$\gamma_d = 0.05 f^{1/3} \quad (36)$$

### For the ducting model

Calculate the reduction in attenuation arising from direct coupling into over-sea ducts (dB):

$$A_c = \frac{-6}{(1 + d_c)} \quad (37)$$

where  $d_c$  (km) is the distance from a land based earth station to the coast in the direction being considered.

$d_c$  is zero in other circumstances.

Calculate the minimum loss to be achieved within the iterative calculations:

$$A_1 = 122.43 + 16.5 \log f + A_h + A_c \quad (38)$$

For the main or supplementary contour:

$$L_3(p) = L_b(p) - A_1 \quad (39a)$$

For an auxiliary contour:

$$L_{3q}(p) = L_{bq}(p) - A_1 \quad (39b)$$

where:

$L_b(p)$  (dB) and  $L_{bq}(p)$  (dB): minimum required loss required for  $p\%$  of the time for the main or supplementary contour and the auxiliary contour with value  $Q$  (dB) respectively (see equation (22)).

### For the tropospheric scatter model

Calculate the frequency-dependent part of the losses (dB):

$$L_f = 25 \log(f) - 2.5 \left[ \log \left( \frac{f}{2} \right) \right]^2 \quad (40)$$

## AP7-34

Calculate the non-distance-dependent part of the losses (dB):

$$A_2 = 187.36 + 10\varepsilon_h + L_f - 0.15 N_0 - 10.1 \left( -\log \left( \frac{p}{50} \right) \right)^{0.7} \quad (41)$$

where:

$\varepsilon_h$ : earth station horizon elevation angle (degrees)

$N_0$ : path centre sea level surface refractivity (see equation (11), § 4.1 in the main body of this Appendix).

Calculate the minimum required value for the distance dependent losses (dB):

For the main, or supplementary, contour:

$$L_A(p) = L_b(p) - A_2 \quad (42a)$$

For an auxiliary contour:

$$L_{Aq}(p) = L_{bq}(p) - A_2 \quad (42b)$$

where:

$L_b(p)$  (dB) and  $L_{bq}(p)$  (dB): minimum required loss required for  $p\%$  of the time for the main or supplementary contour and the auxiliary contour of value  $Q$  (dB) respectively (see equation (22)).

### Iterative calculations

At the start of each iteration, calculate the distance considered for  $i = 0, 1, 2, \dots$ :

$$d_i = d_{min} + i \cdot s \quad (43)$$

Calculate the specific attenuation due to gaseous absorption (dB/km):

$$\gamma_g = \gamma_o + \gamma_{wdl} \left( \frac{d_t}{d_i} \right) + \gamma_{wds} \left( 1 - \frac{d_t}{d_i} \right) \quad (44)$$

where:

$d_t$  (km): current aggregate land distance, Zone A1 + Zone A2, along the current path.

Calculate the following zone-dependent parameters:

$$\tau = 1 - \exp \left[ - \left( 4.12 \times 10^{-4} (d_{lm})^{2.41} \right) \right] \quad (45)$$

where:

$d_{lm}$  (km): longest continuous inland distance, Zone A2, along the path considered;

$$\mu_1 = \left[ 10^{\frac{-d_{lm}}{16 - 6.6 \tau}} + \left[ 10^{-(0.496 + 0.354 \tau)} \right]^5 \right]^{0.2} \quad (46)$$

where:

$d_{lm}$  (km): longest continuous land (i.e. inland + coastal) distance, Zone A1 + Zone A2 along the path considered.

$\mu_1$  shall be limited to  $\mu_1 \leq 1$ .

$$\sigma = -0.6 - 8.5 \times 10^{-9} d_i^{3.1} \tau \quad (47)$$

$\sigma$  shall be limited to  $\sigma \geq -3.4$ .

$$\mu_2 = \left( 2.48 \times 10^{-4} d_i^2 \right)^\sigma \quad (48)$$

$\mu_2$  shall be limited to  $\mu_2 \leq 1$ .

$$\mu_4 = \begin{cases} 10^{(-0.935 + 0.0176 \zeta_r) \log \mu_1} & \text{for } \zeta_r \leq 70^\circ \\ 10^{0.3 \log \mu_1} & \text{for } \zeta_r > 70^\circ \end{cases} \quad (49a)$$

$$\text{for } \zeta_r > 70^\circ \quad (49b)$$

where  $\zeta_r$  is given in equations (9) and (10), § 4.1 in the main body of this Appendix.

Calculate the path-dependent incidence of ducting,  $\beta$ , and a related parameter,  $\Gamma_1$  used to calculate the time dependency of the path loss:

$$\beta = \beta_e \cdot \mu_1 \cdot \mu_2 \cdot \mu_4 \quad (50)$$

where  $\beta_e$  is given in equations (7) and (8), § 4.1 in the main body of this Appendix.

$$\Gamma_1 = \frac{1.076}{(2.0058 - \log \beta)^{1.012}} \exp \left[ - \left( 9.51 - 4.8 \log \beta + 0.198 (\log \beta)^2 \right) \times 10^{-6} d_i^{1.13} \right] \quad (51)$$

Calculate the correction factor,  $C_{2i}$  (dB) (see § 4.4 in the main body of this Appendix) using:

$$C_{2i} = \begin{cases} Z(f)(d_i - d_{min})\tau & \text{dB} & \text{for the main or supplementary contour} \\ 0 & \text{dB} & \text{for the auxiliary contour} \end{cases} \quad (52)$$

where  $Z(f)$  is calculated using equation (21) in § 4.4 in the main body of this Appendix.

At distances greater than 375 km the value of the correction factor  $C_{2i}$  in equation (52) to be applied is the value of  $C_{2i}$  at the 375 km distance.

Calculate the distance-dependent part of the losses (dB) for ducting:

$$L_5(p) = (\gamma_d + \gamma_g) d_i + (1.2 + 3.7 \times 10^{-3} d_i) \log \left( \frac{p}{\beta} \right) + 12 \left( \frac{p}{\beta} \right)^{\Gamma_1} + C_{2i} \quad (53)$$

and for tropospheric scatter:

$$L_6(p) = 20 \log (d_i) + 5.73 \times 10^{-4} (112 - 15 \cos (2\zeta)) d_i + (\gamma_o + \gamma_{wt}) d_i + C_{2i} \quad (54)$$

For the determination of distances for auxiliary contours,  $C_{2i} = 0$  dB.

#### 4 Frequencies between 60 GHz and 105 GHz

This propagation model is valid for average annual percentage time ( $p$ ) in the range from 0.001% to 50%.

An iterative process is used to determine the propagation mode (1) required distance. First, equations (55) to (59) are evaluated. Then commencing at the minimum coordination distance,  $d_{min}$ , equations (60) and (61) are iterated for distances  $d_i$ , where  $i = 0, 1, 2, \dots$ , incremented in steps of  $s$  (km) as described in § 1.3 of the main body of this Appendix. For each iteration,  $d_i$  is the distance considered.

This process is continued until either of the following expressions becomes true:

$$L_9(p) \geq \begin{cases} L_8(p) & \text{for the main or supplementary contour} \\ L_{8q}(p) & \text{for the auxiliary contour} \end{cases} \quad (54a)$$

or:

$$d_i \geq \begin{cases} d_{max1} & \text{for the main or supplementary contour} \\ d_1 & \text{for the auxiliary contour} \end{cases} \quad (54b)$$

The required distance,  $d_1$ , or the auxiliary contour distance  $d_q$  are then given by the current distance for the last iteration: i.e.

$$d_1 = d_i \quad (54c)$$

or:

$$d_q = d_i \quad (54d)$$

Calculate the specific attenuation (dB/km) for dry air in the frequency range 60 GHz to 105 GHz using:

$$\gamma_{om} = \begin{cases} \left[ 2 \times 10^{-4} (1 - 1.2 \times 10^{-5} f^{1.5}) + \frac{4}{(f - 63)^2 + 0.936} + \frac{0.28}{(f - 118.75)^2 + 1.771} \right] f^2 6.24 \times 10^{-4} & \text{dB/km for } f > 63.26 \text{ GHz} \\ 10 & \text{dB/km for } f \leq 63.26 \text{ GHz} \end{cases} \quad (55a)$$

$$10 \quad \text{dB/km for } f \leq 63.26 \text{ GHz} \quad (55b)$$

Calculate the specific attenuation (dB/km) for an atmospheric water vapour density of 3 g/m<sup>3</sup> using:

$$\gamma_{wm} = (0.039 + 7.7 \times 10^{-4} f^{0.5}) f^2 \cdot 2.369 \times 10^{-4} \quad (56)$$

Calculate a conservative estimate of the specific attenuation (dB/km) for gaseous absorption using:

$$\gamma_{gm} = \gamma_{om} + \gamma_{wm} \quad \text{dB/km} \quad (57)$$

For the required frequency and the value of earth station site shielding,  $A_h$  (dB), as calculated using the method described in § 1 of this Annex, calculate the minimum loss to be achieved in the iterative calculations:

$$L_7(p) = 92.5 + 20 \log(f) + A_h \quad \text{dB} \quad (58)$$

For the main or supplementary contour:

$$L_8(p) = L_b(p) - L_7 \quad \text{dB} \quad (59a)$$

For an auxiliary contour:

$$L_{8q}(p) = L_{bq}(p) - L_7 \quad \text{dB} \quad (59b)$$

where:

$L_b(p)$  (dB) and  $L_{bq}(p)$  (dB): minimum required loss required for  $p\%$  of the time for the main or supplementary contour and the auxiliary contour of value  $Q$  (dB) respectively (see equation (22)).

### Iterative calculations

At the start of each iteration calculate the distance for  $i = 0, 1, 2, \dots$ :

$$d_i = d_{min} + i \cdot s \quad (60)$$

Calculate the distance-dependent losses for the distance:

$$L_9(p) = \gamma_{gm} d_i + 20 \log(d_i) + 2.6 \left[ 1 - \exp\left(\frac{-d_i}{10}\right) \right] \log\left(\frac{p}{50}\right) \quad (61)$$

For frequencies above 60 GHz, the correction factor (see § 4.4 in the main body of this Appendix) is 0 dB. Therefore, no correction term has been added to equation (61).

ANNEX 2

**Determination of the required distance for propagation mode (2)**

**1 Overview**

The algorithm given below allows propagation mode (2) path loss,  $L_r(p)$  (dB), to be obtained as a monotonic function of rainfall rate,  $R(p)$  (mm/h), and with the hydrometeor scatter distance,  $r_i$  (km), as a parameter. The model is valid for average annual time percentage ( $p$ ) in the range 0.001% to 10%. The procedure to determine the hydrometeor scatter contour is as follows:

- a) The value of  $R(p)$ , is determined for the appropriate rain climatic Zones A to Q.
- b) Values of  $L_r(p)$ , are then calculated for incremental values of  $r_i$ , starting at the minimum coordination distance  $d_{min}$ , in steps of  $s$  (km), as described in § 1.3 of the main body of this Appendix. The correct value of  $r_i$  is that for which the corresponding value of  $L_r(p)$  equals or exceeds the propagation mode (2) minimum required loss  $L(p)$ . This value of  $r_i$  is the propagation mode (2) required distance and is denoted  $d_r$ .
- c) If the iterative calculation results in  $r_i$  equalling or exceeding the appropriate maximum calculation distance ( $d_{max2}$ ) given in § 2, then the calculation is terminated and  $d_r$  is assumed to be equal to  $d_{max2}$ . Hence the iteration stops when either of the following expressions becomes true:

$$L_r(p) \geq L(p) \tag{62a}$$

or:

$$r_i \geq d_{max2} \tag{62b}$$

- d) The contour for propagation mode (2) is a circle of radius  $d_r$  (km) centred on a point along the azimuth of the earth station antenna main beam at a horizontal distance of  $\Delta d$  (km) from the earth station.

**2 Maximum calculation distance**

As discussed in § 1.5.3 of the main body of this Appendix, it is necessary to set upper limits to the maximum distance used in the iterative calculation of the required distance. The maximum calculation distance to be used for propagation mode (2) ( $d_{max2}$ ) is latitude dependent and is given in the following equation:

$$d_{max2} = \sqrt{17\,000(h_R + 3)} \quad \text{km}$$

where  $h_R$  is defined in equations (74) and (75).

**3 Calculation of the propagation mode (2) contour**

Determine  $R(p)$ , the rainfall rate (mm/h) exceeded on average for  $p\%$  of a year. The world has been divided into a number of rain climatic zones (see Figs. 2, 3 and 4) which show different precipitation characteristics.

FIGURE 2

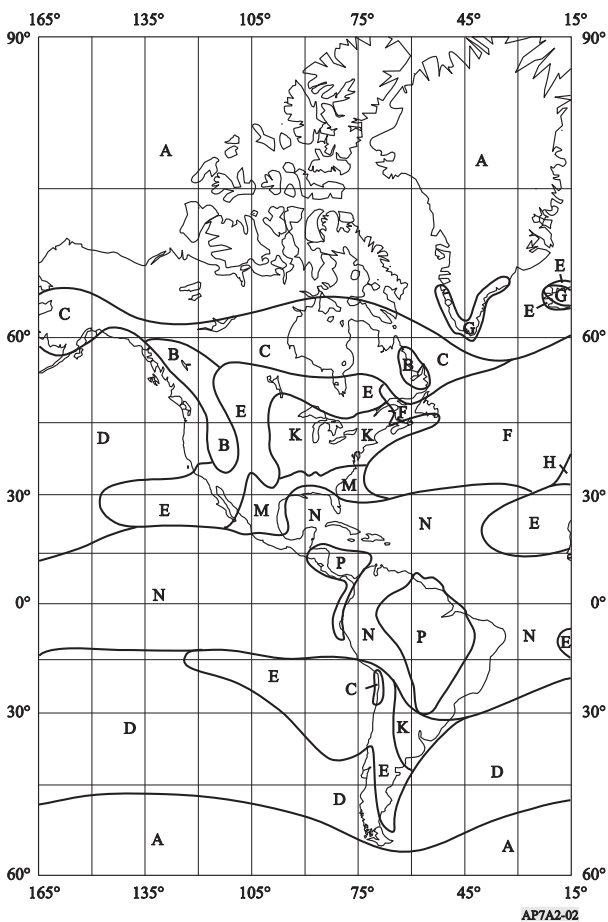
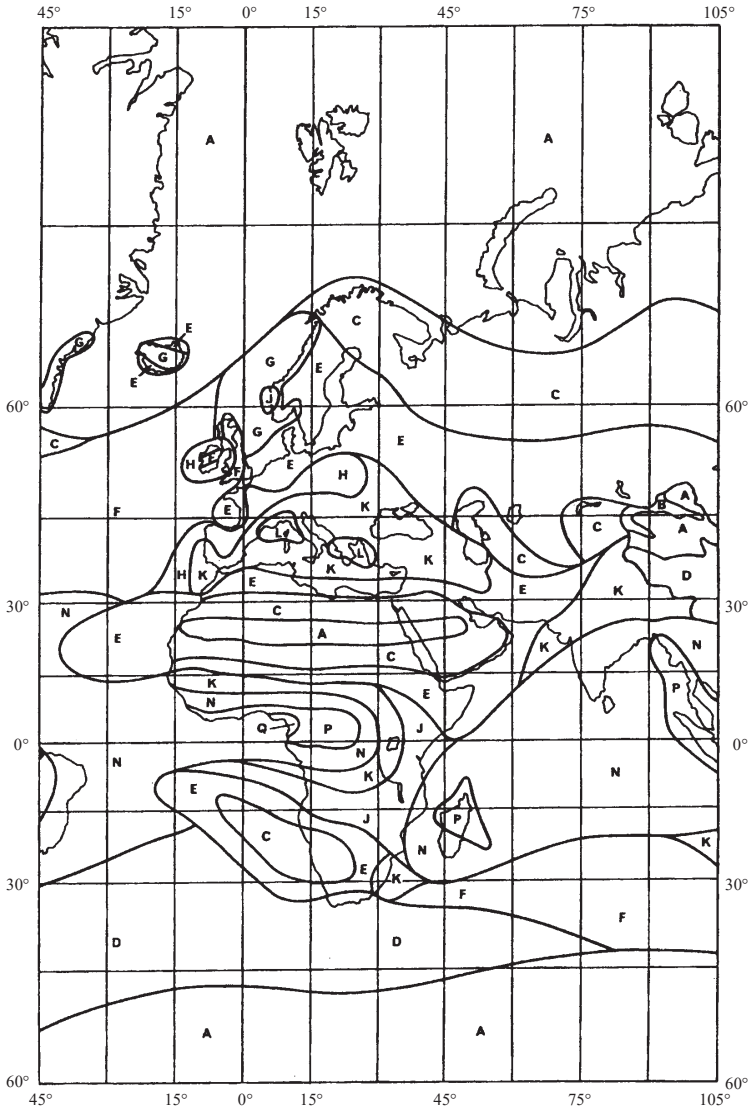

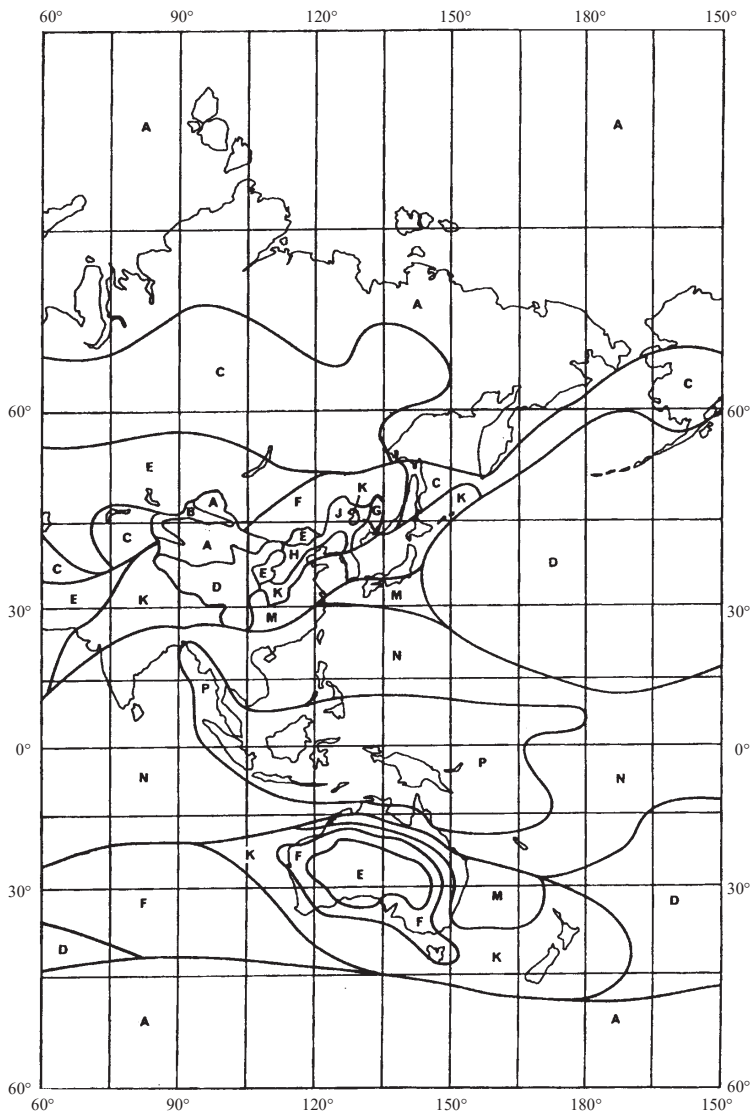

FIGURE 3



AP7A2-03

FIGURE 4



AP7A2-04

The curves shown in Fig. 5 represent consolidated rainfall-rate distributions, each applicable to several of these rain climatic zones.

Determine which rain climatic zone is applicable to the location of the earth station:

- For  $0.001\% < p < 0.3\%$  and the applicable rain climatic zone:  
Determine  $R(p)$  either from Fig. 5 or from equations (63) to (67).
- For  $p \geq 0.3\%$ :  
Use equation (68) with values of  $R(0.3\%)$  and  $p_c$  obtained from Table 4.

FIGURE 5  
Consolidated cumulative distributions of rainfall rate for the rain climatic zones shown in Figs. 2, 3 and 4

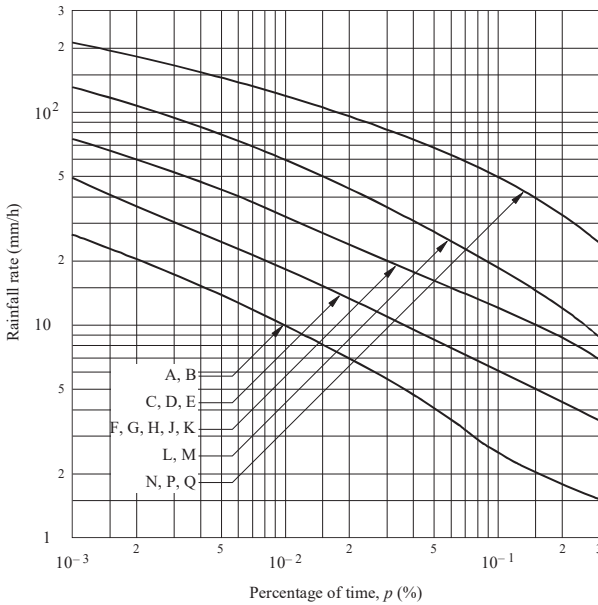

AP7A2-05

Rain climatic Zones A, B

$$R(p) = 1.1 p^{-0.465} + 0.25 \left[ \log ( p/0.001 ) \log^3 ( 0.3/p ) \right] - \left[ \left| \log ( p/0.1 ) \right| + 1.1 \right]^{-2} \text{ mm/h} \quad (63)$$

Rain climatic Zones C, D, E

$$R(p) = 2 p^{-0.466} + 0.5 \left[ \log ( p/0.001 ) \log^3 ( 0.3/p ) \right] \text{ mm/h} \quad (64)$$

Rain climatic Zones F, G, H, J, K

$$R(p) = 4.17 p^{-0.418} + 1.6 \left[ \log ( p/0.001) \log^3 ( 0.3/p) \right] \quad \text{mm/h} \quad (65)$$

Rain climatic Zones L, M

$$R(p) = 4.9 p^{-0.48} + 6.5 \left[ \log ( p/0.001) \log^2 ( 0.3/p) \right] \quad \text{mm/h} \quad (66)$$

Rain climatic Zones N, P, Q

$$R(p) = 15.6 \left( p^{-0.383} + \left[ \log ( p/0.001) \log^{1.5} ( 0.3/p) \right] \right) \quad \text{mm/h} \quad (67)$$

TABLE 4

Values of  $R$  and  $p_c$  for the different rain climatic zones

Rain climatic zone	$R$ (0.3%) (mm/h)	$p_c$ (%)
A, B	1.5	2
C, D, E	3.5	3
F, G, H, J, K	7.0	5
L, M	9.0	7.5
N, P, Q	25.0	10

where:

$p_c$  (%): reference time percentage above which the rainfall rate  $R(p)$  can be assumed to be zero.

$$R(p) = R(0.3\%) \left[ \frac{\log(p_c/p)}{\log(p_c/0.3)} \right]^2 \quad (68)$$

Determine the specific attenuation (dB/km) due to rain using values of  $k$  and  $\alpha$  from Table 5 in equation (70). Values of  $k$  and  $\alpha$  at frequencies other than those in Table 5 can be obtained by interpolation using a logarithmic scale for frequency, a logarithmic scale for  $k$  and a linear scale for  $\alpha$ .

TABLE 5

Values of  $k$  and  $\alpha$  for vertical polarization as a function of the frequency

Frequency (GHz)	$k$	$\alpha$
1	0.0000352	0.880
4	0.000591	1.075
6	0.00155	1.265
8	0.00395	1.31
10	0.00887	1.264
12	0.0168	1.20
14	0.029	1.15
18	0.055	1.09
20	0.0691	1.065
22.4	0.090	1.05
25	0.113	1.03
28	0.150	1.01
30	0.167	1.00
35	0.233	0.963
40	0.310	0.929
40.5	0.318	0.926

Let:

$$R = R(p) \tag{69}$$

Then the specific attenuation (dB/km) due to rain is given by:

$$\gamma_R = k R^\alpha \tag{70}$$

Calculate the effective diameter of the rain cell:

$$d_s = 3.5 R^{-0.08} \tag{71}$$

Then, calculate the effective scatter transfer function:

$$R_{cv} = \frac{2.17}{\gamma_R d_s} \left( 1 - 10^{-\frac{\gamma_R d_s}{5}} \right) \tag{72}$$

Calculate the additional attenuation outside the common volume:

$$\Gamma_2 = 631 k R^{(\alpha - 0.5)} \times 10^{-(R + 1)^{0.19}} \tag{73}$$

Determine the rain height above ground,  $h_R$  (km):

For North America and Europe west of 60° E longitude:

$$h_R = 3.2 - 0.075 (\zeta - 35) \quad \text{for } 35 \leq \zeta \leq 70 \quad (74)$$

where:

$\zeta$ : latitude of the coordinating earth station.

For all other areas of the world:

$$h_R = \begin{cases} 5 - 0.075 (\zeta - 23) & \text{for } \zeta > 23 & \text{Northern hemisphere} & (75a) \\ 5 & \text{for } 0 \leq \zeta \leq 23 & \text{Northern hemisphere} & (75b) \\ 5 & \text{for } 0 \geq \zeta \geq -21 & \text{Southern hemisphere} & (75c) \\ 5 + 0.1 (\zeta + 21) & \text{for } -71 \leq \zeta < -21 & \text{Southern hemisphere} & (75d) \\ 0 & \text{for } \zeta < -71 & \text{Southern hemisphere} & (75e) \end{cases}$$

Determine the specific attenuation due to water vapour absorption (a water vapour density of 7.5 g/m<sup>3</sup> is used):

$$\gamma_{wr} = \left[ 0.06575 + \frac{3.6}{(f - 22.2)^2 + 8.5} \right] f^2 \cdot 7.5 \times 10^{-4} \quad (76)$$

### 3.1 Iterative calculations

Evaluate equations (77) to (82) inclusive for increasing values of  $r_i$ , where  $r_i$  is the current distance considered (km) between the region of maximum scattering and the possible location of a terrestrial station and  $i = 0, 1, 2, \dots$ . Continue this process until either of the conditions given in equations (62a) and (62b) is true. Then the rain-scatter required distance  $d_r$  is the current value of  $r_i$ .

$$r_i = d_{min} + i \cdot s \quad (77)$$

Determine the loss above the rain height,  $L_{ar}$  (dB), applicable to scatter coupling:

$$L_{ar} = \begin{cases} 6.5 \left[ 6 (r_i - 50)^2 \times 10^{-5} - h_R \right] & \text{for } 6 (r_i - 50)^2 \times 10^{-5} > h_R \quad (78a) \\ 0 & \text{for } 6 (r_i - 50)^2 \times 10^{-5} \leq h_R \quad (78b) \end{cases}$$

Calculate the additional attenuation for the departure from Rayleigh scattering:

$$A_b = \begin{cases} 0.005 (f - 10)^{1.7} R^{0.4} & \text{for } 10 \text{ GHz} < f < 40.5 \text{ GHz} & (79a) \\ 0 & \text{for } f < 10 \text{ GHz or when } L_{ar} \neq 0 & (79b) \end{cases}$$

Calculate the effective path length for oxygen absorption:

$$d_o = \begin{cases} 0.7 r_i + 32 & \text{for } r_i < 340 \text{ km} \\ 270 & \text{for } r_i \geq 340 \text{ km} \end{cases} \quad (80a)$$

$$(80b)$$

Calculate the effective path length for water vapour absorption:

$$d_v = \begin{cases} 0.7 r_i + 32 & \text{for } r_i < 240 \text{ km} \\ 200 & \text{for } r_i \geq 240 \text{ km} \end{cases} \quad (81a)$$

$$(81b)$$

Determine the propagation mode (2) path loss,  $L_r$  (dB):

$$L_r = 168 + 20 \log r_i - 20 \log f - 13.2 \log R - G_x + A_b - 10 \log R_{cv} + \Gamma_2 + L_{ar} + \gamma_o d_o + \gamma_{wr} d_v \quad (82)$$

where:

$\gamma_o$ : as given in equation (33)

$G_x$ : terrestrial network antenna gain in Tables 7 or 8.

#### 4 Construction of the propagation mode (2) contour

In order to determine the centre of the circular propagation mode (2) contour, it is necessary to calculate the horizontal distance to this point from the earth station, along the azimuth of the earth station antenna main beam axis. The distance,  $\Delta d$  (km), to the centre of the propagation mode (2) contour is given by:

$$\Delta d = \frac{h_R}{2 \tan \epsilon_s} \quad (83)$$

where:

$\epsilon_s$ : earth station antenna main beam axis elevation angle

and

$\Delta d$ : shall be limited to the distance  $(d_r - 50)$  km.

The propagation mode (2) required distance,  $d_r$ , must lie within the range between the minimum coordination distance,  $d_{min}$ , and the propagation mode (2) maximum calculation distance,  $d_{max2}$ .

Draw the propagation mode (2) contour as a circle of radius  $d_r$  (km) around the centre determined above. The propagation mode (2) contour is the locus of points on this circle. However, if any part of the propagation mode (2) contour falls within the contour defined by the minimum coordination distance, this arc of the propagation mode (2) contour is taken to be identical to the contour based on the minimum coordination distance and the propagation mode (2) contour is then no longer circular.

ANNEX 3

**Antenna gain towards the horizon for an earth station operating with a geostationary space station**

**1 General**

The gain component of the earth station antenna in the direction of the physical horizon around an earth station is a function of the angular separation between the antenna main beam axis and the horizon in the direction under consideration. When the earth station is used to transmit to a space station in a slightly inclined orbit, all possible pointing directions of the antenna main beam axis need to be considered. For earth station coordination, knowledge of  $\varphi(\alpha)$ , the minimum possible value of the angular separation that will occur during the operation of the space station, is required for each azimuth.

When a geostationary space station maintains its location close to its nominal orbital position, the earth station's main beam axis elevation angle,  $\epsilon_s$ , and the azimuth angle,  $\alpha_s$ , to the space station from the earth station's latitude,  $\zeta$ , are uniquely related. Figure 6 shows the possible location arcs of positions of a space station on the geostationary orbit in a rectangular azimuth/elevation plot. It shows arcs corresponding to a set of earth station latitudes and the intersecting arcs correspond to points on the orbit with a fixed difference in longitude East or West of the earth station. Figure 6 also shows a portion of the horizon profile  $\epsilon_h(\alpha)$ . The off-axis angle  $\varphi(\alpha)$  between the horizon profile at an azimuth of  $190^\circ$  and a space station located  $28^\circ$  W of an earth station at  $43^\circ$  N latitude is indicated by the great-circle arc shown dashed on Fig. 6.

FIGURE 6  
**Position arcs of geostationary satellites with horizon and the arc from the horizon at azimuth  $190^\circ$  to a satellite  $28^\circ$  W of an earth station at  $43^\circ$  N latitude**

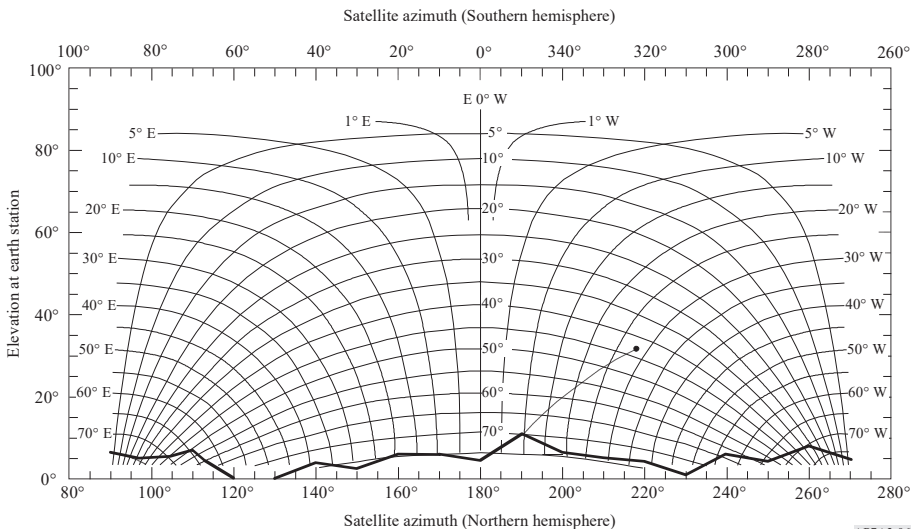

AP7A3-06



When the north/south station-keeping of a geostationary satellite is relaxed, the orbit of the satellite becomes inclined, with an inclination that increases gradually with time. As viewed from the Earth, the position of the satellite traces a figure eight during each 24-hour period. Figure 7 shows the variations in the trajectories of a set of satellites, each with 10° inclination, spaced by 3° along the geostationary orbit from 28° W to 44° E, with respect to an earth station at 43° N latitude. Figure 7 also shows, with a dashed curve, the great-circle arc corresponding to the minimum off-axis angle  $\varphi(\alpha)$  between a point on the trajectory of one of the satellites and the horizon profile at an azimuth of 110°.

FIGURE 7  
**Position arcs of geostationary satellites with horizon and the arc from the horizon at azimuth 110° to satellites with 10° inclination on the geostationary orbital arc from 28° W to 44° E of an earth station at 43° N latitude**

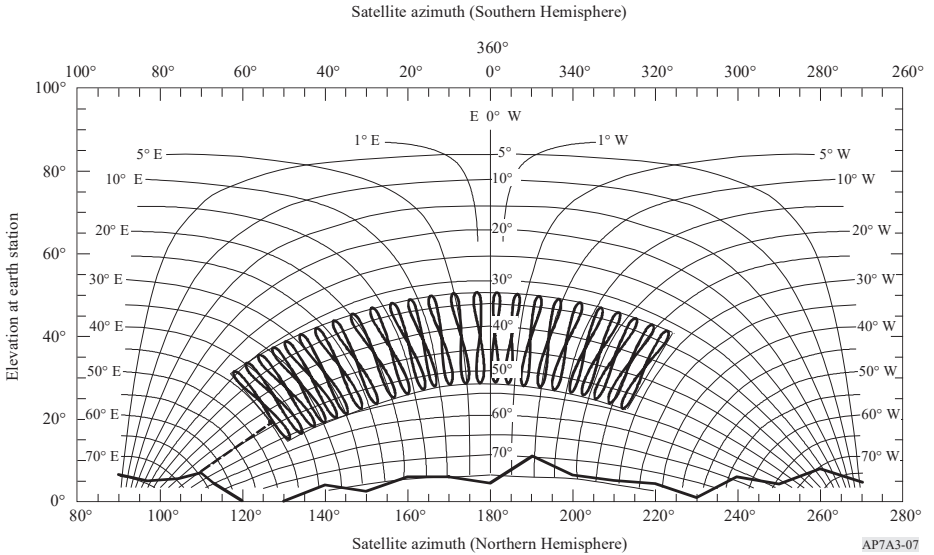

For a transmitting earth station operating in a frequency band that is also allocated for bidirectional use by receiving earth stations operating with geostationary space stations, refer to § 2.1 of Annex 5.

## 2 Determination of the angular separation $\varphi(\alpha)$

For the determination of the off-axis angle  $\varphi(\alpha)$ , two cases are distinguished. These depend on whether the orbit of the space station has no inclination, or is slightly inclined. The following equations may be used in both of these cases:

$$\psi_s(i, \delta) = \arccos(\sin \zeta \sin i + \cos \zeta \cos i \cos \delta) \tag{84}$$

$$\varepsilon_s(i, \delta) = \arcsin \left( \frac{K \cos \psi_s(i, \delta) - 1}{(1 + K^2 - 2K \cos \psi_s(i, \delta))^{1/2}} \right) \tag{85}$$

$$\alpha_{0s}(i, \delta) = \arccos \left[ \frac{\sin i - \cos \psi_s \sin \zeta}{\sin \psi_s \cos \zeta} \right] \quad (86)$$

$$\alpha_s(i, \delta) = \alpha_{0s}(i, \delta) \quad \text{for a space station located east of the earth station } (\delta \geq 0) \quad (87)$$

$$\alpha_s(i, \delta) = 360^\circ - \alpha_{0s}(i, \delta) \quad \text{for a space station located west of the earth station } (\delta \leq 0) \quad (88)$$

$$\varphi(\alpha, i, \delta) = \arccos \left[ \cos \varepsilon_h(\alpha) \cos \varepsilon_s(i, \delta) \cos(\alpha - \alpha_s(i, \delta)) + \sin \varepsilon_h(\alpha) \sin \varepsilon_s(i, \delta) \right] \quad (89)$$

where:

- $\zeta$ : latitude of the earth station (positive for north; negative for south)
- $\delta$ : difference in longitude between the earth station and a space station
- $i$ : latitude of a sub-satellite point (positive for north; negative for south)
- $\psi_s(i, \delta)$ : great-circle arc between the earth station and a sub-satellite point
- $\alpha_s(i, \delta)$ : space station azimuth as seen from the earth station
- $\varepsilon_s(i, \delta)$ : space station elevation angle as seen from the earth station
- $\varphi(\alpha, i, \delta)$ : angle between the main beam and the horizon direction corresponding to the azimuth,  $\alpha$ , under consideration when the main beam is steered towards a space station with a sub-satellite point at latitude,  $i$ , and longitude difference,  $\delta$
- $\alpha$ : azimuth of the direction under consideration
- $\varepsilon_h$ : elevation angle of the horizon at the azimuth under consideration,  $\alpha$
- $\varphi(\alpha)$ : angle to be used for horizon gain calculation at the azimuth under consideration,  $\alpha$
- $K$ : orbit radius/Earth radius, which for the geostationary orbit is assumed to be 6.62.

All arcs mentioned above are in degrees.

### Case 1: Single space station, no orbital inclination

For a space station operating with no orbital inclination at an orbital position with difference in longitude  $\delta_0$ , equations (84) to (89) may be applied directly using  $i = 0$  to determine  $\varphi(\alpha)$  for each azimuth  $\alpha$ . Thus:

$$\varphi(\alpha) = \varphi(\alpha, 0, \delta_0) \quad (90)$$

where:

- $\delta_0$ : difference in longitude between the earth station and the space station.

### Case 2: Single space station, slightly inclined orbit

For a space station operating in a slightly inclined orbit on a portion of the geostationary arc with a nominal longitude difference of  $\delta_0$ , the maximum orbital inclination over its lifetime,  $i_s$ , must be considered. Equations (84) to (89) may be applied to develop the minimum off-axis angle to each of four arcs in azimuth/elevation that bound the trajectory of the space station in angle and elevation. The bounding arcs correspond to the maximum and minimum latitudes of the sub-satellite points and the extremes of the difference in longitude between the earth and space stations when the space station is operating at its maximum inclination.

The determination of the minimum off-axis angles in equations (91) to (95) may be made by taking increments along a bounding contour. The step size in inclination  $i$  or longitude  $\delta$  should be between  $0.5^\circ$  and  $1.0^\circ$  and the end points of the respective ranges should be included in the calculation.

The horizon profile  $\varepsilon_h(\alpha)$  used in the determination of  $\varphi(\alpha)$  is specified at increments in azimuth  $\alpha$  that do not exceed  $5^\circ$ .

Thus:

$$\varphi(\alpha) = \min_{n=1 \text{ to } 4} \varphi_n(\alpha) \quad (91)$$

with:

$$\varphi_1(\alpha) = \min_{\delta_0 - \delta_s \leq \delta \leq \delta_0 + \delta_s} \varphi(\alpha, -i_s, \delta) \quad (92)$$

$$\varphi_2(\alpha) = \min_{\delta_0 - \delta_s \leq \delta \leq \delta_0 + \delta_s} \varphi(\alpha, i_s, \delta) \quad (93)$$

$$\varphi_3(\alpha) = \min_{-i_s \leq i \leq i_s} \varphi(\alpha, i, \delta_0 - \delta_s) \quad (94)$$

$$\varphi_4(\alpha) = \min_{-i_s \leq i \leq i_s} \varphi(\alpha, i, \delta_0 + \delta_s) \quad (95)$$

$$\delta_s = \left( \frac{i_s}{15} \right)^2 \quad (96)$$

where:

$i_s$ : maximum operational inclination angle of the satellite orbit

$\delta_s$ : maximum longitude change from nominal value of the sub-satellite point of a satellite with orbital inclination  $i_s$ .

### 3 Determination of antenna gain

The relationship  $\varphi(\alpha)$  is used to derive a function for the horizon antenna gain (dBi),  $G(\varphi)$  as a function of the azimuth  $\alpha$ , by using the actual earth station antenna pattern, or a formula giving a good approximation. For example, in cases where the ratio between the antenna diameter and the wavelength is equal to or greater than 35, the following equation is used:

$$G(\varphi) = \begin{cases} G_{amax} - 2.5 \times 10^{-3} \left( \frac{D}{\lambda} \varphi \right)^2 & \text{for } 0 < \varphi < \varphi_m \\ G_1 & \text{for } \varphi_m \leq \varphi < \varphi_r \\ 29 - 25 \log \varphi & \text{for } \varphi_r \leq \varphi < 36^\circ \\ -10 & \text{for } 36^\circ \leq \varphi \leq 180^\circ \end{cases} \quad (97)$$

$$G_1 = \begin{cases} -1 + 15 \log (D/\lambda) & \text{dBi} & \text{for } D/\lambda \geq 100 \\ -21 + 25 \log (D/\lambda) & \text{dBi} & \text{for } 35 \leq D/\lambda < 100 \end{cases}$$

$$\varphi_m = \frac{20 \lambda}{D} \sqrt{G_{amax} - G_1} \quad \text{degrees}$$

$$\varphi_r = \begin{cases} 15.85 (D/\lambda)^{-0.6} & \text{degrees} & \text{for } D/\lambda \geq 100 \\ 100 (\lambda/D) & \text{degrees} & \text{for } 35 \leq D/\lambda < 100 \end{cases}$$

Where a better representation of the actual antenna pattern is available, it may be used.

In cases where  $D/\lambda$  is not given, it may be estimated from the expression:

$$20 \log \frac{D}{\lambda} \approx G_{amax} - 7.7$$

where:

$G_{amax}$ : main beam axis antenna gain (dBi)

$D$ : antenna diameter (m)

$\lambda$ : wavelength (m)

$G_1$ : gain of the first side lobe (dBi).

## ANNEX 4

### Antenna gain toward the horizon for an earth station operating with non-geostationary space stations

This Annex presents methods which may be used to determine the antenna gain towards the horizon for an earth station operating to non-geostationary satellites using the TIG method described in § 2.2 of the main body of this Appendix.

#### 1 Determination of the horizon antenna gain

In its simplest implementation, the TIG method depends on the minimum elevation angle of the beam axis of the earth station antenna ( $\varepsilon_{sys}$ ), which is a system parameter that has the same value on all azimuths from the earth station. If the horizon elevation angle at an azimuth under consideration is  $\varepsilon_h$  (degrees), the minimum separation angle from the horizon at this azimuth to any possible pointing angle for the main beam axis of the antenna ( $\varphi_{min}$ ) is equal to the difference between these two angles ( $\varepsilon_{sys} - \varepsilon_h$ ), but it is not less than zero degrees. The maximum separation angle from the horizon at this azimuth to any possible pointing angle for the main beam axis of the antenna ( $\varphi_{max}$ ) is equal to the difference between the sum of these two angles and  $180^\circ$  ( $180 - \varepsilon_{sys} - \varepsilon_h$ ). The maximum and minimum values of horizon gain for the azimuth under consideration are obtained from the gain pattern of the earth station antenna at these off-axis angles. Where no pattern is available the pattern of § 3 of Annex 3 may be used.

Additional constraints may be included in the determination of the maximum and minimum values of horizon antenna gain where an earth station operates with a constellation of non-geostationary satellites that are not in near-polar orbit. In this case, depending on the latitude of the earth station, there may be portions of the hemisphere above the horizontal plane at the earth station in which no satellite will appear. To include these visibility limitations within this method, it is first necessary to determine, for a closely spaced set of azimuth angles around the earth station, the minimum elevation angle at which a satellite may be visible. This minimum satellite visibility elevation angle ( $\varepsilon_v$ ) may be determined from consideration of the visibility of the edge of the shell formed by all possible orbits having the orbital inclination and altitude of the satellites in the constellation.

The lowest elevation angle towards which the main-beam axis of the earth station antenna will point on any azimuth is the minimum composite elevation angle ( $\varepsilon_c$ ), which is equal to the greater of the minimum satellite visibility elevation angle ( $\varepsilon_v$ ) and the minimum elevation angle of the earth station ( $\varepsilon_{\text{sys}}$ ). After the minimum composite elevation angle has been determined for all azimuths by the procedure of § 1.1 of this Annex, the resulting profile of the minimum composite elevation angles can be used, in the procedure of § 1.2 of this Annex, to determine the maximum and minimum values of horizon gain at any azimuth.

Further information and an example of this method may be found in the most recent version of Recommendation ITU-R SM.1448. (WRC-15)

### 1.1 Determination of satellite visibility limits

The visibility limits of a constellation of satellites can be determined from the inclination angle of the most inclined satellite and the altitude of the lowest satellite in the constellation. For this determination, six cases may be distinguished, but not all of these may be applicable for a given constellation and a given earth station latitude. The azimuth and the corresponding lower limit on the elevation angle are developed by a parametric method using a set of points on the edge of the orbital shell of the constellation. The approach is to develop this relationship for azimuths to the east of a station in the northern hemisphere. Elevation angles for azimuths to the west of the station and for all azimuths for stations in the southern hemisphere are obtained by symmetry. The following equations, which are applicable to circular orbits only, may be used for the complete determination of the horizon antenna gain in all practical cases:

$$\psi(\delta) = \arccos(\sin \zeta_e \sin i_s + \cos \zeta_e \cos i_s \cos \delta) \quad (98)$$

$$\varepsilon_v(\delta) = \arcsin \left[ \frac{K_1 \cos[\psi(\delta)] - 1}{(1 + K_1^2 - 2K_1 \cos[\psi(\delta)])^{1/2}} \right] \quad (99)$$

$$\alpha_0(\delta) = \arccos \left[ \frac{\sin i_s - \cos[\psi(\delta)] \sin \zeta_e}{\sin[\psi(\delta)] \cos \zeta_e} \right] \quad (100)$$

with:

$$\alpha(\delta) = \begin{cases} \alpha_0(\delta) \text{ and} \\ 360^\circ - \alpha_0(\delta) & \text{for earth stations north of the Equator} \\ 180^\circ - \alpha_0(\delta) \text{ and} \\ 180^\circ + \alpha_0(\delta) & \text{for earth stations south of the Equator} \end{cases} \quad (101)$$

where:

- $i_s$ : orbital inclination of the satellites in the constellation assumed to be positive and between  $0^\circ$  and  $90^\circ$
- $\zeta_e$ : modulus of the latitude of the earth station
- $\delta$ : difference in longitude from the earth station to a point on the edge of the orbital shell of the constellation
- $\psi(\delta)$ : great-circle arc between the earth station and a point on the surface of the Earth directly below the point on the edge of the orbital shell of the constellation
- $\alpha(\delta)$ : azimuth from the earth station to a point on the edge of the orbital shell
- $\alpha_0(\delta)$ : principal azimuth, an azimuth between  $0^\circ$  and  $180^\circ$ , from an earth station to a point on the edge of the orbital shell
- $\varepsilon_v(\delta)$ : elevation angle from the earth station to a point on the edge of the orbital shell
- $K_1$ : orbit radius/Earth radius for the lowest altitude satellite in the constellation (Earth radius = 6 378.14 km)
- $\psi_m = \arccos(1/K_1)$ .

All arcs mentioned above are in degrees.

For any latitude on the surface of the Earth, the azimuth for which the minimum elevation angle to a satellite can be greater than zero, and the corresponding elevation angles, may be determined by implementing the calculations under the following case(s). No more than two of these cases will be applicable for any latitude. For situations not specifically addressed in the following cases, no satellite is visible at elevation angles at or below  $90^\circ$  on any azimuth.

**Case 1:** For:  $\zeta_e \leq i_s - \psi_m$

For this case, a satellite may be visible to the horizon for all azimuths about the earth station ( $\varepsilon_v = 0$ ).

**Case 2:** For:  $i_s - \psi_m < \zeta_e \leq \arcsin(\sin i_s \cos \psi_m)$

For this case, the azimuth angles and elevation are developed parametrically by choosing a set of values of  $\delta$ , uniformly spaced on the interval 0 to  $\delta_1$ , and applying equations (98) to (101). For this purpose the spacing between values is not to exceed 1.0°, and the end points are to be included.

$$\delta_1 = \arccos \left[ \frac{\cos \psi_m - \sin \zeta_e \sin i_s}{\cos \zeta_e \cos i_s} \right]$$

At any principal azimuth ( $\alpha_0(\delta)$ ) that is not included in the set, the minimum elevation angle is zero ( $\epsilon_v = 0$ ), except for azimuths where Case 6 additionally applies.

**Case 3:** For:  $\arcsin(\sin i_s \cos \psi_m) < \zeta_e < i_s$  and  $\zeta_e < 180^\circ - \psi_m - i_s$

For this case, the azimuth angles and elevation are developed parametrically by choosing a set of values of  $\delta$ , uniformly spaced on the interval 0 to  $\delta_2$ , and applying equations (98) to (101). For this purpose the spacing between values is not to exceed 1.0°, and the end points are to be included.

$$\delta_2 = 2 \arctan \left[ \frac{\sqrt{\sin^2 \psi_m - \cos^2 i_s \sin^2 \delta_1}}{\sin \zeta_e \cos i_s \sin \delta_1} \right] - \delta_1$$

At any principal azimuth ( $\alpha_0(\delta)$ ) that is not included in the set, the minimum elevation angle is zero ( $\epsilon_v = 0$ ), except for azimuths where Case 6 additionally applies.

**Case 4:** For:  $i_s \leq \zeta_e < i_s + \psi_m$  and  $\zeta_e < 180^\circ - i_s - \psi_m$

For this case, the minimum elevation angle is given explicitly in terms of the principal azimuth angle  $\alpha_0$ , as follows:

$$\epsilon_v = \begin{cases} 90^\circ & \text{for } 0 \leq \alpha_0 < \alpha_2 \\ 0 & \text{for } \alpha_2 \leq \alpha_0 \leq 180^\circ \end{cases}$$

where:

$$\alpha_2 = \arccos \left[ \frac{\sin i_s - \cos \psi_m \sin \zeta_e}{\sin \psi_m \cos \zeta_e} \right]$$

Note that a minimum elevation angle of 90° in this formulation indicates that no satellite is visible at elevation angles at or below 90° on these azimuths. Furthermore, within the range of principal azimuths where the minimum elevation angle is zero, Case 6 may additionally apply.

**Case 5:** For  $180^\circ - i_s - \psi_m \leq \zeta_e \leq 90^\circ$

For this case, a satellite may be visible to the horizon for all azimuths about the earth station ( $\epsilon_v = 0$ ).

**Case 6:** For  $\zeta_e < \psi_m - i_s$

This case may occur additionally with Case 2, Case 3 or Case 4 and a satellite may be visible only above a minimum elevation angle for other principal azimuths.

For this case, the other principal azimuths and the corresponding elevation angles are developed parametrically by choosing a set of values of  $\delta$ , uniformly spaced on the interval 0 to  $\delta_3$ , and applying equations (98) to (101) with  $i_s$  replaced by  $-i_s$ . For this purpose the spacing between values is not to exceed  $1.0^\circ$  and the end points are to be included.

$$\delta_3 = \arccos \left[ \frac{\cos \psi_m + \sin \zeta_e \sin i_s}{\cos \zeta_e \cos i_s} \right]$$

## 1.2 Determination of minimum and maximum horizon gain from the minimum visible elevation angle profile

The horizon gain of the earth station antenna is determined from the profile of values of the minimum composite elevation angle ( $\varepsilon_c$ ). At any azimuth, the minimum composite elevation angle is the greater of the minimum satellite visibility elevation angle at that azimuth ( $\varepsilon_v$ ) and the minimum elevation angle for the earth station ( $\varepsilon_{sys}$ ). The following procedure may be used to determine the maximum and minimum values of horizon antenna gain for each azimuth under consideration.

The following equation may be used to determine the angular separation between the horizon profile, at an azimuth angle  $\alpha$  and horizon elevation angle  $\varepsilon_h$ , and a point on the profile of the minimum composite elevation angle, where the minimum composite elevation angle is  $\varepsilon_c$  at an azimuth angle of  $\alpha_c$ :

$$\varphi(\alpha, \alpha_c) = \arccos \left[ \sin \varepsilon_h(\alpha) \sin(\varepsilon_c(\alpha_c)) + \cos \varepsilon_h(\alpha) \cos(\varepsilon_c(\alpha_c)) \cos(\alpha - \alpha_c) \right] \quad (102)$$

where:

- $\alpha$ : azimuth of the direction under consideration
- $\varepsilon_h(\alpha)$ : elevation angle of the horizon at the azimuth under consideration,  $\alpha$
- $\varepsilon_c(\alpha_c)$ : minimum composite elevation angle at the azimuth,  $\alpha_c$
- $\alpha_c$ : azimuth corresponding to  $\varepsilon_c$ .

The minimum value of the separation angle  $\varphi_{min}$ , for the azimuth under consideration, is determined by finding the minimum value of  $\varphi(\alpha, \alpha_c)$  for any azimuth  $\alpha_c$ , and the maximum value,  $\varphi_{max}$ , is determined by finding the maximum value of  $\varphi(\alpha, \alpha_c)$  for any azimuth  $\alpha_c$ . The azimuth angles ( $\alpha$ ) are usually taken in increments of  $5^\circ$ ; however, to accurately determine the minimum separation angle, the values of the minimum composite elevation angle,  $\varepsilon_c$ , need to be determined for a spacing of  $1^\circ$  or less in the azimuth  $\alpha_c$ . Where the procedures in § 1.1 of this Annex do not provide a profile of minimum composite elevation angle with a close enough spacing in azimuth angles, linear interpolation may be used to develop the necessary intermediate values. The maximum and minimum horizon antenna gains,  $G_{max}$  and  $G_{min}$ , to be used in the equations of § 2.2 of the main body of this Appendix for the azimuth under consideration are obtained by applying the off-axis angles,  $\varphi_{min}$  and  $\varphi_{max}$ , respectively, in the earth station antenna pattern. If the earth station antenna pattern is not known then the antenna pattern in § 3 of Annex 3 is used. In many cases,  $\varphi_{max}$  will be large enough on all azimuths so that  $G_{min}$  will be equal to the minimum gain of the antenna pattern at all azimuths.



## ANNEX 5

**Determination of the coordination area for a transmitting earth station  
with respect to receiving earth stations operating with  
geostationary space stations in bidirectionally  
allocated frequency bands**

## 1 Introduction

The propagation mode (1) contour of a transmitting earth station with respect to unknown receiving earth stations operating with geostationary space stations requires the determination of the horizon gain of the antenna of the receiving earth station at each azimuth of the transmitting earth station. Different methods then need to be applied to determine the coordination area of the coordinating earth station, depending on whether it operates with geostationary or non-geostationary space stations. When both the coordinating earth station and the unknown receiving earth stations operate with geostationary space stations, it is also necessary to determine a propagation mode (2) contour.

The coordination area of a transmitting earth station, with respect to unknown receiving earth stations that operate to non-geostationary space stations, can be determined by minor modifications to the methods applicable to the determination of coordination area of transmitting earth stations with respect to terrestrial stations. (See § 3.2.1 and § 3.2.3 of the main body of the Appendix.)

## 2 Determination of the bidirectional contour for propagation mode (1)

For a transmitting earth station operating in a frequency band that is also allocated for bidirectional use by receiving earth stations operating with geostationary space stations, further development of the procedures in Annex 3 is needed. It is necessary to determine the horizon gain of the unknown receiving earth station, the horizon gain to be used at each azimuth at the coordinating (transmitting) earth station, for the determination of the bidirectional contour.

### 2.1 Calculation of horizon gain for unknown receiving earth stations operating with geostationary space stations

The value of  $G_r$ , the horizon gain of the receiving earth station, for each azimuth,  $\alpha$ , at the transmitting earth station is found by the following steps:

*Step 1:* The receiving earth station may be operating with any satellite in the geostationary orbit above a minimum elevation angle,  $\varepsilon_{min}$ , contained in Table 9. The maximum difference in longitude ( $\delta_b$  (degrees)) between the receiving earth station and its associated space station occurs at this minimum elevation angle,  $\varepsilon_{min}$ , and is given by:

$$\delta_b = \arccos \left( \frac{\sin \left( \varepsilon_{min} + \arcsin \left( \frac{\cos(\varepsilon_{min})}{K} \right) \right)}{\cos(\zeta)} \right) \quad (103)$$

where:

$\zeta$ : latitude of the receiving earth station, which is assumed to be the same as the transmitting earth station

$K$ : ratio of the radius of the satellite orbit to the radius of the Earth, equal to 6.62.

*Step 2:* For each azimuth,  $\alpha$ , at the transmitting earth station:

– determine the azimuth  $\alpha_r$  from the receiving earth station to the transmitting earth station:

$$\alpha_r = \alpha + 180^\circ \quad \text{for } \alpha < 180^\circ$$

$$\alpha_r = \alpha - 180^\circ \quad \text{for } \alpha \geq 180^\circ$$

– for each azimuth  $\alpha_r$ , determine the minimum angular separation,  $\varphi(\alpha_r)$ , between the receiving earth station main beam axis and the horizon at this azimuth using Case 1 in § 2 of Annex 3. For this evaluation,  $\varphi(\alpha_r)$  is the minimum value of  $\varphi(\alpha_r, 0, \delta_0)$ , where the values of  $\delta_0$  are between  $-\delta_b$  and  $+\delta_b$  in steps of  $1^\circ$  or less, making sure to include the end points.

The minimum angular separation,  $\varphi(\alpha_r)$ , may be used with the gain pattern in § 3 of Annex 3 to determine the horizon gain for this azimuth,  $\alpha$ , unless a different gain pattern is referenced in Table 9.

Figure 8 shows plots of the minimum angular separation between the horizon at zero degrees elevation on an azimuth  $\alpha_r$  and a satellite on the geostationary orbit at an elevation above  $3^\circ$ . Plots are shown for a set of values of the station latitude,  $\zeta$ , which is assumed to be the same for both transmitting and receiving earth stations. Figure 8 also provides a scale showing the corresponding azimuth,  $\alpha$ , of the transmitting earth station.

Further information and an example may be found in the most recent version of Recommendation ITU-R SM.1448. (WRC-15)

FIGURE 8  
 Illustration of minimum angular distance between points on the geostationary-satellite orbit (GSO) and the horizontal plane

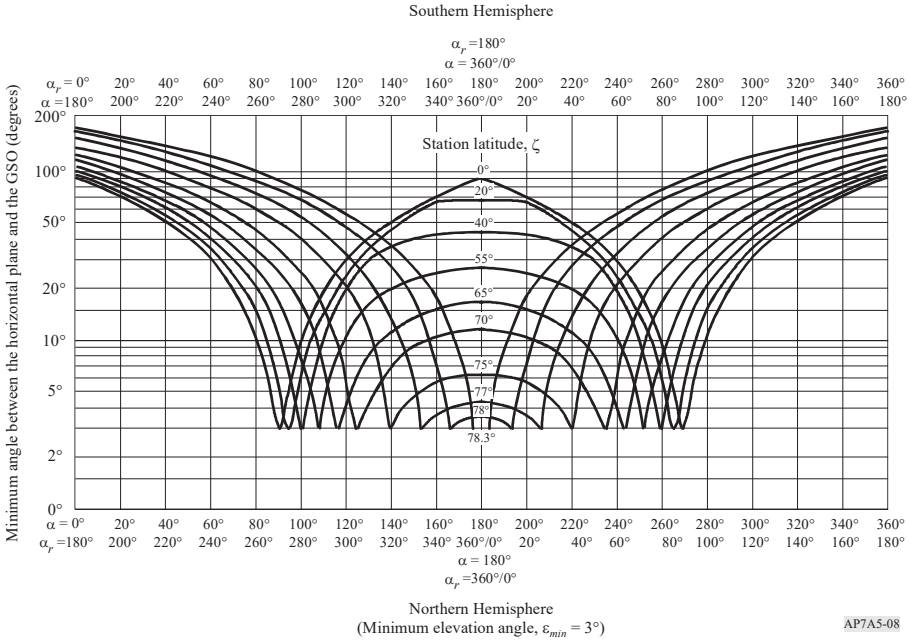

### 3 Determination of the bidirectional rain scatter contour

The procedure for the determination of the bidirectional rain scatter area, as described in § 3.1.2 of the main body of this Appendix, is as follows:

The horizontal distance  $d_s$  (km) from the coordinating earth station to the point at which the main beam axis attains the rain height  $h_R$  is calculated by:

$$d_s = 8\,500 \left( \sqrt{\tan^2 \epsilon_s + h_R / 4\,250} - \tan \epsilon_s \right) \quad \text{km} \quad (104)$$

where the rain height,  $h_R$ , can be determined from equations (74) or (75) in Annex 2 and  $\epsilon_s$  is the minimum elevation angle of the transmitting earth station.

The maximum calculation distance,  $d_{emax}$ , to be used in the determination of the propagation mode (2) contour, for the case of a coordinating earth station operating in bidirectionally allocated frequency bands, is dependent on the rain height. It is the greater distance determined from:

$$d_{emax} = 130.4 \sqrt{h_R} \quad \text{km} \quad \text{or} \quad d_{min}$$

where the minimum coordination distance,  $d_{min}$ , is given in § 4.2 of the main body of this Appendix.

The point, at the distance  $d_s$  from the earth station, on the azimuth  $\alpha_s$  of the coordinating earth station's main beam axis, is the geographic point immediately below the main beam axis intersection with the rain height, and is the reference point from which the maximum calculation distance  $d_{emax}$  is determined (see Fig. 9).

If the maximum calculation distance,  $d_{emax}$ , is greater than the minimum coordination distance,  $d_{min}$ , then calculate the maximum latitude at which a receiving earth station may operate with a geostationary satellite with a minimum elevation angle  $\varepsilon_{min}$ :

$$\zeta_{max} = \arccos \left[ \frac{\cos(\varepsilon_{min})}{K} \right] - \varepsilon_{min} \quad (105)$$

where:

$\varepsilon_{min}$ : given in Table 9

$K$ : ratio of the radius of the satellite orbit to the radius of the Earth, equal to 6.62.

If the coordinating earth station latitude in the northern hemisphere is greater than  $\zeta_{max}$ , or if the coordinating earth station latitude in the southern hemisphere is less than  $-\zeta_{max}$  or  $-71^\circ$ , then the rain scatter contour is a circle of radius  $d_{min}$ , centred on the transmitting earth station.

For all other cases, the coordination area is developed by the following procedure:

*Step 1:* The unknown receiving earth station is assumed to be operating with a satellite at the minimum elevation angle  $\varepsilon_{min}$ . It is also assumed that the receiving earth station is relatively close to the coordinating earth station in geometric terms and hence a plane geometry approximation can be applied within the coordination area. If the receiving earth station's main beam axis passes through the intersection of the coordinating earth station's main beam axis with the rain height, the azimuths from the point on the ground immediately below this intersection to the possible locations of a receiving earth station are given by:

$$\alpha_{w1} = \arccos \left[ \frac{\tan \zeta}{\tan \zeta_{max}} \right]$$

and

$$\alpha_{w2} = 360^\circ - \alpha_{w1}$$

where  $\zeta$  is the latitude of the transmitting earth station.

*Step 2:* Mark on a map of an appropriate scale the coordinating earth station's location and draw from this location a line of distance,  $d_s$ , along the azimuth,  $\alpha_s$ , to the point below the coordinating earth station's main beam axis intersection with the rain height.

*Step 3:* From the main beam axis intersection point in Step 2, mark on the map the distance,  $d_{emax}$ , along the two azimuths,  $\alpha_{w2}$  and  $\alpha_{w1}$ , and on each azimuth at the distance,  $d_{emax}$ , draw two equal distance arcs of width  $3^\circ$  clockwise and counter-clockwise. The two arcs, each having a total width of  $6^\circ$ , are the first boundary elements of the bidirectional rain scatter area.

Step 4: Mark a circle of radius equal to the minimum coordination distance,  $d_{min}$ , around the coordinating earth station's location, and then draw straight lines from the northern edges of the two arc segments tangential to the northern rim of the circle, and from the southern edges of the two arc segments tangential to the southern rim of the circle.

The area bounded by the two  $6^\circ$  wide arcs, the four straight lines, and the circular sections (of which there is always at least one) between the two northern and the two southern tangent points with the straight lines, constitutes the bidirectional rain scatter area.

Figure 9 illustrates the construction of the bidirectional rain scatter area for a coordinating earth station. (The resulting rain scatter area contains the possible loci of all receiving earth station locations from which a beam path towards the geostationary-satellite orbit will intersect the main beam of the transmitting earth station antenna.)

FIGURE 9  
 Example of the bidirectional rain scatter area  
 (Not to scale)

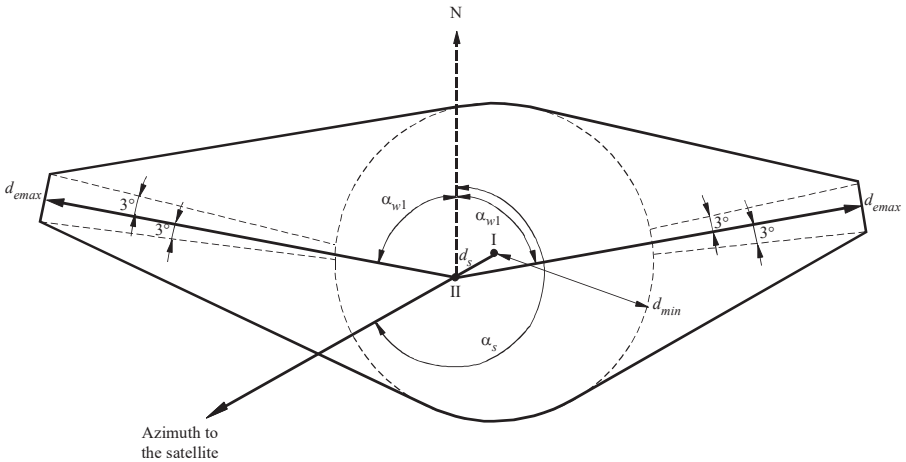

- I: location of the transmitting earth station
- II: point where the earth station antenna main-beam axis reaches the altitude  $h_r$

Assumptions:  
 $\zeta = 40^\circ$  N  
 $\epsilon_s = 10^\circ$   
 $\alpha_s = 254^\circ$

## ANNEX 6

**Supplementary and auxiliary contours****1 Introduction**

The material found in this Annex is intended to assist administrations in bilateral discussions.

**2 Supplementary contours**

The coordination area is determined with respect to the type of terrestrial station (or, in a frequency band with a bidirectional space allocation, an earth station operating in the opposite direction of transmission) that would yield the largest coordination distances. Therefore, in the case of terrestrial services, fixed stations using tropospheric scatter have been assumed to be operating in frequency bands that may typically be used by such radiocommunication systems; and fixed stations operating in line-of-sight configurations and using analogue modulation have been assumed to be operating in other frequency bands. However, other radiocommunication systems (e.g. other terrestrial stations), that typically have lower antenna gains, or otherwise less stringent system parameters, than those on which the coordination area is based, may also operate in the same frequency range. Therefore, it is possible for the administration seeking coordination to identify a supplementary contour using either the methods in § 2 or 3 of the main body of this Appendix, where they are applicable, or other agreed methods. Subject to bilateral agreement between administrations, these supplementary contours can assume the role of the coordination contour for an alternative type of radio system in the same service or another radiocommunication service.

When a supplementary contour is to be developed for other types of systems, for example digital fixed systems, the necessary system parameters may be found in one of the adjacent columns in Tables 7, 8 and 9. If no suitable system parameters are available then the value of the permissible interference power ( $P_i(p)$ ) may be calculated using equation (127) of § 2 in Annex 7.

In addition, supplementary contours may be prepared by the administration seeking coordination in order to define smaller areas, based on more detailed methods, for consideration when agreed bilaterally between the concerned administrations. These contours can be a useful aid for the rapid exclusion of terrestrial stations or earth stations from further consideration. For earth stations operating with non-geostationary space stations, supplementary contours may be generated using the method in § 4 of this Annex.

Supplementary contours may comprise propagation mode (1) interference paths and, depending on the sharing scenario, propagation mode (2) interference paths. In addition, the propagation mode (1) element of a supplementary contour may, if appropriate for the radiocommunication service, utilize the same level of correction factor (see § 4.4 of the main body of this Appendix) that was applied in the determination of the coordination contour. However, all parts of each supplementary contour must fall on or between the contour defined by the minimum coordination distance and the corresponding propagation mode (1) or propagation mode (2) main contour.

### 3 Auxiliary contours

Practical experience has shown that, in many cases, the separation distance required for the coordinating earth station, on any azimuth, can in fact be substantially less than the coordination distance, since the worst-case assumptions do not apply to every terrestrial station or earth station. There are two main mechanisms that contribute to such a difference between the separation distance and the coordination distance:

- the terrestrial station antenna gain (or e.i.r.p.), or receiving earth station antenna gain, in the direction of the coordinating earth station is less than that assumed in calculating the coordination contour;
- appropriate allowance can be made, for example, for the effects of site shielding not included in the coordination distance calculations.

Auxiliary contours must use the same method as that used to determine the corresponding main or supplementary contour. In addition, all parts of each auxiliary contour must fall on or between the contour defined by the minimum coordination distance and the corresponding main or supplementary contour. Auxiliary contours may assist in eliminating from detailed coordination terrestrial stations or earth stations that are located in the coordination area and hence have been identified as potentially affected by the coordinating earth station. Any terrestrial station or earth station that lies outside an auxiliary contour and has an antenna gain towards the coordinating earth station that is less than the gain represented by the relevant auxiliary contour need not be considered further as a significant source, or subject, of interference.

#### 3.1 Auxiliary contours for propagation mode (1)

Propagation mode (1) auxiliary contours are calculated with values for the propagation mode (1) minimum required loss in equation (22) in § 4.4 of the main body of this Appendix that are progressively reduced by, for example, 5, 10, 15, 20 dB, etc., below the value derived from the parameters assumed in Tables 7, 8 and 9 for the corresponding main or supplementary propagation mode (1) contour, until the minimum coordination distance is reached. Propagation mode (1) auxiliary contour distances are calculated without the correction factor (see § 4.4 of the main body of this Appendix), and hence could be larger, on any azimuth, than the corresponding main, or supplementary, propagation mode (1) distance. To prevent this, in those cases where a correction factor applies to the main or supplementary contour, the maximum propagation mode (1) auxiliary contour distance on any azimuth is limited to the corresponding main or supplementary propagation mode (1) distance. In effect this means that the correction factor will limit the possible range of auxiliary contour values so that only those auxiliary contours with values greater than the applied correction factor will be shown within the main or supplementary contour (see Fig. 10). For example, if the value of correction factor applicable to the propagation mode (1) main or supplementary contour is 10 dB, then the first auxiliary contour drawn would be for a reduction in minimum required loss of 5 dB and hence the auxiliary contour value would be -15 dB (by convention, auxiliary contours are shown as negative quantities as they represent a reduction in the terrestrial, or receiving earth station, antenna gain, or the terrestrial station e.i.r.p.).

FIGURE 10 (WRC-03)  
**Propagation mode (1) main contour and auxiliary contours**

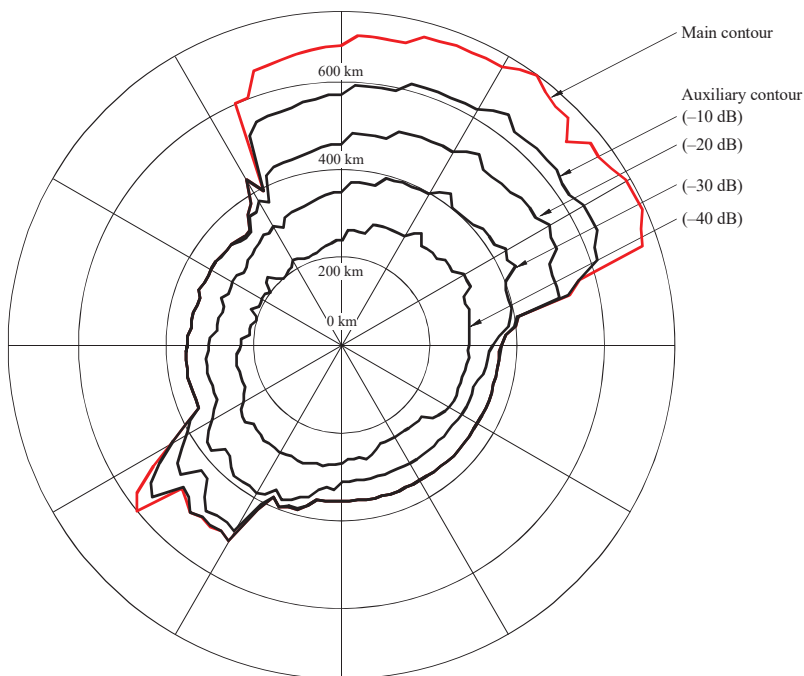

The propagation mode (1) auxiliary contours are shown for -10, -20, -30 and -40 dB adjustments in the minimum required loss.

AP7A6-10

Propagation mode (2) interference effects may still need to be considered even if propagation mode (1) interference effects have been eliminated from detailed coordination, as the propagation models are based on different interference mechanisms.

### 3.2 Auxiliary contours for propagation mode (2)

The propagation mode (2) contour around an earth station is calculated assuming the main beams of the coordinating earth station and the terrestrial station intersect exactly (see § 1.3 of the main body of this Appendix). However, it is unlikely that these antenna main beams will intersect exactly. It is therefore possible to generate propagation mode (2) auxiliary contours that take account of any offset in the pointing of the terrestrial station antenna beam from the direction of the coordinating earth station. This offset would result in partial beam intersections and hence a reduced interference potential. These propagation mode (2) auxiliary contours are calculated according to the method described in § 3.2.1 of this Annex.



Propagation mode (2) auxiliary contours are not generated for different values of antenna gain or e.i.r.p. but for different values of beam avoidance angle. Hence, if there is a need to consider both a lower value of antenna gain, or e.i.r.p., for the terrestrial station and propagation mode (2) auxiliary contours, it is first essential to consider the impact of the reduction in antenna gain, or e.i.r.p., on the propagation mode (2) contour. This is achieved by generating a supplementary contour (see § 2) corresponding to the lower value of antenna gain or e.i.r.p. for the terrestrial station, which is drawn on a separate map. Auxiliary mode (2) contours can then be generated inside this propagation mode (2) supplementary contour for different values of the beam avoidance angle. Hence, propagation mode (2) auxiliary contours may be most frequently applied in conjunction with a supplementary contour rather than with the coordination contour.

The correction factor discussed in § 1.3 of the main body of this Appendix does not apply to propagation mode (2) interference paths and hence is also not applicable to propagation mode (2) auxiliary contours. In addition propagation mode (2) auxiliary contours cannot be developed for the bidirectional case.

Propagation mode (2) auxiliary contours are prepared for appropriate values of terrestrial station main beam avoidance angle (see Fig. 11). When the antenna characteristics of the terrestrial stations are known, the appropriate antenna pattern<sup>9</sup> should be used when determining the propagation mode (2) auxiliary contours. If this is not available, the reference antenna pattern given in § 3.2.3 may be used.

---

<sup>9</sup> The method requires the antenna pattern to be monotonic in terms of the reduction in gain either side of the main beam axis.

FIGURE 11 (WRC-03)

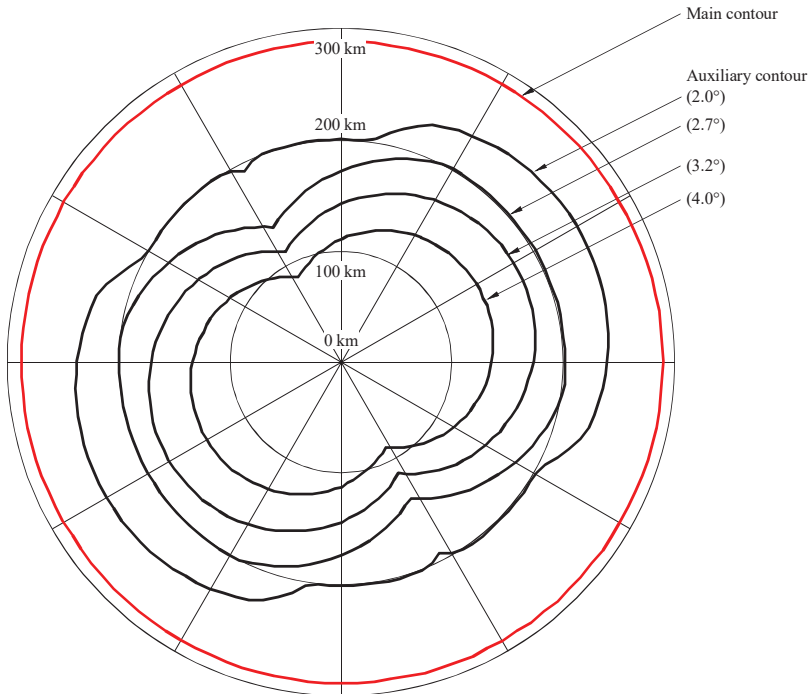
**Propagation mode (2) main contour and auxiliary contours**

The propagation mode (2) auxiliary contours are shown for terrestrial station main beam avoidance angles of 2.0°, 2.7°, 3.2° and 4.0°, respectively

AP7A6-11

### 3.2.1 Determination of auxiliary contours for propagation mode (2)

Propagation mode (2) auxiliary contours allow the azimuthal offset of a terrestrial station antenna beam from the coordinating earth station's location to be taken into consideration. Figure 12 shows the hydrometeor scatter region projected on to the horizontal plane. In this Figure, the earth station and the terrestrial station are located at the points A and B, respectively, where the terrestrial station is on a radial defined by the angle  $\omega$  from the point C at the centre of the propagation mode (2) main, or supplementary, contour. Point C is also the centre of the auxiliary contour.

FIGURE 12  
Propagation geometry in the horizontal plane

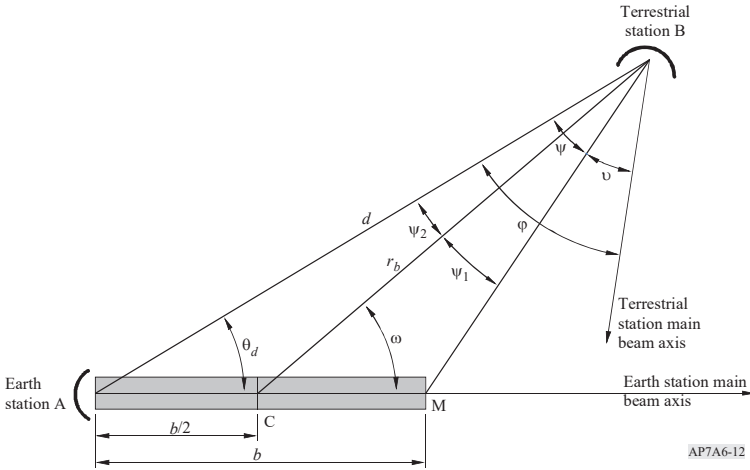

The shaded area in Fig. 12 represents the critical region, along the earth station’s main beam axis, between the earth station and the rain height. Within this critical region a common volume can be formed between the earth station beam and the beam of any terrestrial stations within the propagation mode (2) main, or supplementary, contour. This critical region’s length is  $b$  and its maximum horizontal extent is at point M. Intersection of this critical region by the terrestrial station main beam axis would result in significant hydrometeor scatter interference via main lobe-to-main lobe coupling.

For a given point within the propagation mode (2) main, or supplementary, contour, the angle subtended by the critical region is termed the critical angle,  $\psi$ . The protection angle,  $\nu$ , represents the angle of the terrestrial station main beam axis away from the critical region. The beam avoidance angle between the terrestrial station’s main beam axis and the earth station’s location is  $\phi$ . It is the sum of the two angles  $\psi$  and  $\nu$  and it is this quantity that has a fixed value for a specific auxiliary contour. Each auxiliary contour is generated by varying the angle,  $\omega$ , and deriving the distance,  $r_b$ , from point C to the auxiliary contour. As the angle  $\omega$  increases from  $0^\circ$  to  $360^\circ$ , the angles  $\psi$  and  $\nu$  change, but their sum remains the same.

The algorithm in § 3.2.2 of this Annex can be used to calculate the auxiliary propagation mode (2) contour for a given value of beam avoidance angle  $\phi$ .

The method is based on iteratively decrementing the distance,  $r_b$ , between terrestrial station and the centre of the common volume, and starting at the main contour distance  $d_r$ , until either the shortest value of  $r_b$  is found for which the required minimum loss is achieved, or the minimum coordination distance is reached. For each value of  $r_b$ , the critical angle  $\psi$  is determined and then the protection angle  $\nu$  is calculated. The terrestrial station antenna gain corresponding to  $\nu$  and the current distance  $r_b$  are used to obtain the propagation mode (2) path loss in equation (82) in Annex 2.

The above process is repeated for each angle  $\omega$ , to generate a complete auxiliary contour for a given value of beam avoidance angle  $\phi$ . For some combinations of beam avoidance angle and angle  $\omega$ , an auxiliary contour may coincide with the main, or supplementary, propagation mode (2) contour.

### 3.2.2 The step-by-step algorithm

Auxiliary propagation mode (2) contours are constructed by calculating distances along radials from the centre of the circular mode (2) main, or supplementary, contour, which is the point C, at the distance  $b/2$  from the earth station along the azimuth of its main beam axis. The distance  $b/2$  is equal to  $\Delta d$ , where  $\Delta d$  is given by equation (83) in Annex 2.

For the selected value of beam avoidance angle,  $\phi$ , generate the auxiliary contour for values of angle,  $\omega$ , ranging from  $0^\circ$  to  $180^\circ$  in steps of  $1^\circ$ , as follows:

a) Set  $r_b$  to the main, or supplementary, mode (2) contour distance  $d_r$  calculated as described in § 3.1 of Annex 2.

b) Compute  $\psi$  from:

$$\psi_1 = \arctan \left( \frac{b \sin \omega}{2r_b - b \cos \omega} \right) \quad (106)$$

$$\psi_2 = \arctan \left( \frac{b \sin \omega}{2r_b + b \cos \omega} \right) \quad (107)$$

$$\psi = \psi_1 + \psi_2 \quad (108)$$

c) If  $\psi > \phi$  then the auxiliary mode (2) contour coincides with the main or supplementary mode (2) contour for the current value of  $\omega$ , and the calculation for that value of  $\omega$  is completed, and go to step j). Otherwise proceed through the following steps d) to i) until one of the terminating conditions described in step f) and step i) is satisfied.

d) Decrement  $r_b$  by subtracting 0.2 km from its value.

e) Recalculate the critical angle  $\psi$  using equations (106), (107) and (108).

f) If  $(0.5 b \sin \omega / \sin \psi_2) < d_{min}$ , the auxiliary mode (2) contour coincides with the minimum coordination distance  $d_{min}$  and the calculation for the current value of  $\omega$  is completed – go to step j). Otherwise, proceed to step g).

g) Compute the protection angle  $\upsilon = \phi - \psi$ .

h) Calculate  $G(\upsilon)$ , the terrestrial station antenna gain at the angle  $\upsilon$  relative to the beam axis, using the reference antenna pattern given in this Annex.

i) In equation (82) in Annex 2, use the gain calculated in step h) in place of  $G_x$  and the value considered of  $r_b$  in place of  $r_i$ , and calculate the corresponding propagation mode (2) path loss  $L_r$ . If  $L_r < L(p)$ , then increment  $r_b$  by adding 0.2 km to its value and take this as the distance for the current radial. Otherwise, repeat from step d).

- j) Once the value of  $r_b$  has been found for the current value of angle  $\omega$ , calculate the angle  $\theta_d$  from the location of the earth station, and if appropriate the distance,  $d$ , to that contour point using:

$$d = 0.5 b \sin \omega / \sin \psi_2 \quad (109)$$

$$\theta_d = \omega - \psi_2 \quad (110)$$

An auxiliary propagation mode (2) contour is symmetrical about the earth station main beam axis. Thus, values of  $d$  and  $\theta_d$  corresponding to the values of  $\omega$  from  $181^\circ$  to  $359^\circ$  can be found by noting that results for a given value of  $\omega$  are the same as for  $(-\omega)$  or  $(360^\circ - \omega)$ .

The step size for incrementing  $r_b$  used above, 0.2 km, is suitable for most situations. It controls the granularity of the result when viewed as a set of  $r_b$  values. For low values of earth station beam elevation, the granularity becomes more noticeable in the values of  $d$  and  $\theta_d$ , and a smaller step size may be used.

### 3.2.3 Reference radiation patterns for line-of-sight radio-relay system antennas

The reference radiation pattern for line-of-sight radio-relay system antennas in this section is used for the unknown terrestrial station antenna in the propagation mode (2) auxiliary contour calculations when the actual antenna pattern is not available.

- a) In cases where the ratio between the antenna diameter and the wavelength is greater than 100, the following equation is used:

$$G(\varphi) = G_{amax} - 2.5 \times 10^{-3} \left( \frac{D}{\lambda} \varphi \right)^2 \quad \text{for} \quad 0 < \varphi < \varphi_m \quad (111)$$

$$G(\varphi) = G_1 \quad \text{for} \quad \varphi_m \leq \varphi < \varphi_r \quad (112)$$

$$G(\varphi) = 32 - 25 \log \varphi \quad \text{for} \quad \varphi_r \leq \varphi < 48^\circ \quad (113)$$

$$G(\varphi) = -10 \quad \text{for} \quad 48^\circ \leq \varphi \leq 180^\circ \quad (114)$$

$$G_1 = 2 + 15 \log \frac{D}{\lambda} \quad (115)$$

$$\varphi_m = \frac{20 \lambda}{D} \sqrt{G_{amax} - G_1} \quad (116)$$

$$\varphi_r = 15.85 \left( \frac{D}{\lambda} \right)^{-0.6} \quad (117)$$

- b) In cases where the ratio between the antenna diameter and the wavelength is less than or equal to 100, the following equation is used:

$$G(\varphi) = G_{amax} - 2.5 \times 10^{-3} \left( \frac{D}{\lambda} \varphi \right)^2 \quad \text{for} \quad 0 < \varphi < \varphi_m \quad (118)$$

$$G(\varphi) = G_1 \quad \text{for} \quad \varphi_m \leq \varphi < 100 \frac{\lambda}{D} \quad (119)$$

$$G(\varphi) = 52 - 10 \log \frac{D}{\lambda} - 25 \log \varphi \quad \text{for } 100 \frac{\lambda}{D} \leq \varphi < 48^\circ \quad (120)$$

$$G(\varphi) = 10 - 10 \log \frac{D}{\lambda} \quad \text{for } 48^\circ \leq \varphi \leq 180^\circ \quad (121)$$

c) In cases where only the maximum antenna gain is known,  $D/\lambda$  can be estimated from the following expression:

$$20 \log \frac{D}{\lambda} \approx G_{amax} - 7.7 \quad (122)$$

where:

$G_{amax}$ : main beam axis antenna gain (dBi)

$D$ : antenna diameter (m)

$\lambda$ : wavelength (m)

$G_1$ : gain of the first side lobe (dBi).

#### 4 Determination of a supplementary contour using the time-variant gain (TVG) method

The TVG method requires the cumulative distribution of the time-varying horizon antenna gain of an earth station operating with a non-geostationary space station. In comparison to the TIG method, the TVG method usually produces smaller distances, but requires greater effort in determining the cumulative distribution of the horizon gain of the earth station antenna for each azimuth to be considered.

The TVG method closely approximates the convolution of the distribution of the horizon gain of the earth station antenna and the propagation mode (1) path loss. This method may produce slightly smaller distances than those obtained by an ideal convolution. An ideal convolution cannot be implemented due to the limitations of the current model for propagation mode (1). The propagation mode (1) required distance, at the azimuth under consideration, is taken as the largest distance developed from a set of calculations, each of which is based on equation (4) of the main body of this Appendix. For convenience, in these calculations, this equation may be rewritten for the  $n$ -th calculation in the following form:

$$L_b(p_v) - G_e(p_n) = P_t + G_x - P_r(p) \quad \text{dB} \quad (123)$$

with the constraint:

$$P_v = \begin{cases} 100 p / p_n & \text{for } p_n \geq 2 p \\ 50 & \text{for } p_n < 2 p \end{cases} \quad \%$$

where:

$P_t, P_r(p)$ : as defined in equations in § 1.3 of the main body of this Appendix where  $p$  is the percentage of time associated with permissible interference power  $P_r(p)$

$G_x$ : maximum antenna gain assumed for the terrestrial station (dBi). Tables 7 and 8 give values for  $G_x$  for the various frequency bands

$G_e(p_n)$ : the horizon gain of the coordinating earth station antenna (dBi) that is exceeded for  $p_n\%$  of the time on the azimuth under consideration

$L_b(p_v)$ : the propagation mode (1) minimum required loss (dB) for  $p_v\%$  of the time; this loss must be exceeded by the propagation mode (1) predicted path loss for all but  $p_v\%$  of the time.

The values of the percentages of time,  $p_n$ , to be used in equation (123) are determined in the context of the cumulative distribution of the horizon antenna gain. This distribution needs to be developed for a predetermined set of values of horizon antenna gain spanning the range from the minimum to the maximum values for the azimuth under consideration. The notation  $G_e(p_n)$  denotes the value of horizon antenna gain for which the complement of the cumulative distribution of the horizon antenna gain has the value corresponding to the percentage of time  $p_n$ . The  $p_n$  value is the percentage of time that the horizon antenna gain exceeds the  $n$ -th horizon antenna gain value. The procedure in § 4.1 may be used to develop this distribution.

For each value of  $p_n$ , the value of horizon antenna gain for this time percentage,  $G_e(p_n)$ , is used in equation (123) to determine a propagation mode (1) minimum required loss. The propagation mode (1) predicted path loss is to exceed this propagation mode (1) required loss for no more than  $p_v\%$  of the time, as specified by the constraint associated with equation (123). A series of propagation mode (1) distances are then determined using the procedures described in § 4 of the main body of this Appendix.

The propagation mode (1) required distance is then the maximum distance in the series of propagation mode (1) distances that are obtained for any value of  $p_n$ , subject to the constraint associated with equation (123). A detailed description of the method for using equation (123) to determine the propagation mode (1) required distance is provided in § 4.2.

Further information, including examples, may be found in the most recent version of Recommendation ITU-R SM.1448. (WRC-15)

#### 4.1 Determination of the horizon antenna gain distribution for the TVG method

The TVG method for the determination of an earth station's supplementary contour requires the determination of the horizon antenna gain statistics for all azimuths (in suitable increments, e.g. 5°) around the earth station. In considering the horizon antenna gain of the antenna for either a transmitting or a receiving earth station, only the horizon antenna gain values during the operational time are to be considered. In developing the cumulative distributions of horizon antenna gain, the percentages of time are percentages of operational time. Thus, there may be periods of time for which no horizon antenna gain is specified.

The determination of the horizon antenna gain distribution requires both earth station and orbital information including whether or not station keeping is used to maintain a single orbital path (repeating/non-repeating ground track system). The cumulative distribution of the time-varying horizon gain of a transmitting or a receiving earth station antenna operating with non-geostationary space stations is calculated as follows:

*Step 1:* Simulate the constellation of non-geostationary space stations over a sufficiently long period, with a time step appropriate for orbit altitude, to obtain a valid representation of the antenna gain variations. For repeating ground track constellations, simulate the orbital path for each satellite visible from the earth station over a period of the ground track. For non-repeating ground track constellations, simulate the orbit of each satellite in the constellation over a period long enough to get a stable representation of the distribution.

*Step 2:* At each time step, determine the azimuth and elevation angle of each satellite that is both visible at the earth station and above the minimum elevation angle at which the earth station operates. In addition to the minimum elevation angle, other criteria could be used to avoid certain geometric configurations, e.g. geostationary orbit arc avoidance (no transmission between an earth station and a non-geostationary satellite that is within  $\pm\lambda^\circ$  from the geostationary orbit arc).

*Step 3:* At each step, and for each satellite in communication with the earth station, use the actual earth station antenna pattern, or a formula giving a good approximation of it, to calculate the gain towards the horizon at each azimuth and elevation angle around the earth station.

*Step 4:* Choose a gain increment  $g$  (dB) and partition the gain range by a number of gain levels between  $G_{min}$  and  $G_{max}$ , i.e.  $G = \{G_{min}, G_{min} + g, G_{min} + 2g, \dots, G_{max}\}$ .

These gain levels determine a set of gain intervals so that the  $n$ -th gain interval ( $n = 1, 2, 3, \dots$ ) includes gain values equal to, or greater than,  $G_{min} + (n - 2)g$  and less than  $G_{min} + (n - 1)g$ .

A value of  $g = 0.1$  to  $0.5$  dB is recommended.

For each azimuth on the horizon around the earth station, accumulate the time that the horizon gain takes a value in each gain interval of width  $g$  (dB).

*Step 5:* The probability density function (pdf) on each azimuth is determined by dividing the time in each gain interval by the total simulation time.

*Step 6:* Determine the cumulative distribution function (cdf) of horizon antenna gain at each azimuth by accumulating the gain density function at that azimuth. The value of the required cdf at any specific gain value is the percentage of time that the gain is less than, or equal to, that gain value.

## 4.2 Determination of the supplementary contour distance using the TVG method

This calculation is based on a cumulative distribution of the horizon gain of the earth station antenna for each azimuth to be considered (in suitable angular increments e.g.  $5^\circ$ ). Appropriate distributions for this purpose may be developed by the method in § 4.1. The process for calculating the supplementary contour distance for each azimuth is described in the following procedure.

*Step 1:* From the complementary cumulative distribution of the horizon antenna gain, for the azimuth under consideration, determine the percentage of time  $p_n$  that the horizon gain exceeds the level  $G_{en}$ , where:

$$G_{en} = G_{min} + (n - 1)g \quad (n = 1, 2, 3, \dots) \quad (124)$$

with:

$G_{min}$ : minimum value of horizon gain, and

$g$ : gain increment.



Step 2: For each percentage  $p_n$  that is equal to or greater than  $2p\%$ , the percentage of time to be used in determining the propagation mode (1) path loss is  $p_v$ .

$$p_v = 100 p / p_n \quad \% \quad \text{for } p_n \geq 2p\% \quad (125)$$

For each percentage of time, determine the distance,  $d_n$  (km), for which the propagation mode (1) predicted path loss is equal to the propagation mode (1) minimum required loss, using the propagation model in accordance with § 4 of the main body of this Appendix and the equation:

$$L_{bn}(p_v) = P_t + G_{en} + G_x - P_r(p) \quad \text{dB} \quad (126)$$

The values of  $p_v$  must be within the range of percentage of time of the propagation mode (1) model (see § 1.5.1 of the main body of this Appendix).

Step 3: The propagation mode (1) required distance for the azimuth under consideration is the largest of the distances,  $d_n$  (km), calculated in Step 2, except when this largest distance is attained for the smallest value of  $p_n$  that is equal to or greater than  $2p$  in accordance with equation (125) in Annex 6. In such cases, the propagation mode (1) required distance for the azimuth under consideration is the distance determined from equation (126) in Annex 6 with  $G_{en} = G_{max}$  and  $p_v = 50\%$  where  $G_{max}$  is the maximum value of horizon antenna gain.

Step 4: The propagation mode (1) supplementary contour distance for the azimuth under consideration is the required distance as determined in Step 3, except that the distance must be between the minimum coordination distance,  $d_{min}$ , and the maximum coordination distance,  $d_{max1}$ . These limits are given in § 4.2 and § 4.3 of the main body of this Appendix, respectively.

## ANNEX 7

### System parameters and predetermined coordination distances for determination of the coordination area around an earth station

#### 1 Introduction

Tables 7 to 9 contain the system parameter values required by the methods in the main body of this Appendix to determine the coordination area around an earth station when the band is shared with terrestrial radiocommunication services or other earth stations operating in the opposite direction of transmission.

Table 7 is limited to those system parameter values required for the case of a transmitting earth station sharing with terrestrial services; Table 8 is limited to those parameter values required for the case of a receiving earth station sharing with terrestrial services; Table 9 is limited to those parameter values required for the case of a transmitting earth station which is sharing in a bidirectionally allocated band with other earth stations operating in the opposite direction of transmission.

These system parameter tables include primary allocations to the space and terrestrial services in Article 5 in all bands between 100 MHz and 105 GHz. Some of the columns have incomplete information. In some cases, this is because there is no requirement to calculate coordination distances as pre-determined coordination distances apply. In other cases, the service allocations are new and the systems may not be introduced for some years. Hence, the system parameters are the subject of ongoing development within the Radiocommunication Study Groups.

Parameters specific to the earth station, for which coordination is being sought, are provided to the Radiocommunication Bureau in the format specified in Appendix 4 as part of the notification and coordination procedures.

The row in each table entitled “method to be used” directs the user to the appropriate section of the main body of this Appendix which describes the methods to be followed for the determination of the coordination area.

Note that the earth station for which the coordination area is to be determined is identified by the service designation given in the first row of each table.

When a supplementary contour is to be developed, for example for digital fixed systems, the necessary system parameters may be found in one of the adjacent columns in Tables 7, 8 and 9. If no suitable system parameters are available, then the value of the permissible interference power ( $P_r(p)$ ) may be calculated using equation (127) in § 2.

The predetermined coordination distances specified in Table 10 are used for transmitting and receiving earth stations, in cases defined by the corresponding frequency sharing situation.

## 2 Calculation of the permissible interference power of an interfering emission

Tables 7, 8 and 9 contain values for the parameters which are required for the calculation of the permissible interference power of the interfering emission (dBW), in the reference bandwidth, to be exceeded for no more than  $p\%$  of the time at the receiving antenna terminal of a station subject to interference, from a single source of interference, using the general formula:

$$P_r(p) = 10 \log(k T_e B) + N_L + 10 \log(10^{M_s/10} - 1) - W \quad \text{dBW} \quad (127)$$

where:

- $k$ : Boltzmann's constant ( $1.38 \times 10^{-23}$  J/K)
- $T_e$ : thermal noise temperature of the receiving system (K), at the terminal of the receiving antenna (see § 2.1 of this Annex)
- $N_L$ : link noise contribution (see § 2.2 of this Annex)
- $B$ : reference bandwidth (Hz), i.e. the bandwidth in the receiving station that is subject to the interference and over which the power of the interfering emission can be averaged
- $p$ : percentage of the time during which the interference from one source may exceed the permissible interference power value; since the entries of interference are not likely to occur simultaneously,  $p = p_0/n$
- $p_0$ : percentage of the time during which the interference from all sources may exceed the threshold value

$n$ : number of equivalent, equal level, equal probability entries of interference, assumed to be uncorrelated for small percentages of the time

$M_s$ : link performance margin (dB) (see § 2.3 of this Annex)

$W$ : a thermal noise equivalence factor (dB) for interfering emissions in the reference bandwidth; it is positive when the interfering emissions would cause more degradation than thermal noise (see § 2.4 of this Annex).

In certain cases, an administration may have reason to believe that, for its receiving earth station, a departure from the values associated with the earth station, as listed in Table 8, may be justified. Attention is drawn to the fact that for specific systems the bandwidths  $B$  or, for example in the case of demand assignment systems, the percentages of the time  $p$  and  $p_0$  may have to be changed from the values given in Table 8.

**2.1 Calculation of the noise temperature of the receiving system**

The noise temperature (K) of the receiving system, referred to the output terminals of the receiving antenna, may be determined (unless specifically given in Table 7) from:

$$T_e = T_a + (\ell_{t1} - 1) 290 + \ell_{t1} T_r \quad \text{K} \quad (128)$$

where:

$T_a$ : noise temperature (K) contributed by the receiving antenna

$\ell_{t1}$ : numerical loss in the transmission line (e.g. a waveguide) between the antenna terminal and the receiver front end

$T_r$ : noise temperature (K) of the receiver front end, including all successive stages at the front end input.

For radio-relay receivers and where the waveguide loss of a receiving earth station is not known, a value of  $\ell_{t1} = 1.0$  is used.

In case of determination of the coordination contours between two earth stations operating in the opposite direction of transmission, the following earth station receiving system noise temperatures should be used if the value is not provided in Table 9. This assumption is necessary because the receiving earth station takes the place of a receiving terrestrial station in the calculations.

TABLE 6

Frequency range (GHz)	$T_e$ (K)
$f < 10$	75
$10 < f < 17$	150
$f > 17$	300

## 2.2 Determination of the factor $N_L$

The factor  $N_L$  is the noise contribution to the link. In the case of a satellite transponder, it includes the uplink noise, intermodulation, etc. In the absence of table entries, it is assumed:

$$\begin{aligned} N_L &= 1 \text{ dB} \text{ for fixed-satellite links} \\ &= 0 \text{ dB} \text{ for terrestrial links} \end{aligned}$$

## 2.3 Determination of the factor $M_S$

The factor  $M_S$  is the factor by which the link noise under clear-sky conditions would have to be raised in order to equal the permissible interference power.

## 2.4 Determination of the factor $W$

The factor  $W$  (dB) is the level of the radio-frequency thermal noise power relative to the received power of an interfering emission which, in the place of the former and contained in the same (reference) bandwidth, would produce the same interference (e.g. an increase in the voice or video channel noise power, or in the bit error ratio). The factor  $W$  generally depends on the characteristics of both the wanted and the interfering signals.

When the wanted signal is digital,  $W$  is usually equal to or less than 0 dB, regardless of the characteristics of the interfering signal.

## 3 Horizon antenna gain for a receiving earth station with respect to a transmitting earth station

For the determination of the coordination area of a transmitting earth station with respect to a receiving earth station in a bidirectionally allocated band, it is necessary to calculate the horizon antenna gain of the unknown earth station. In cases where the unknown receiving earth stations operate with geostationary satellites, Table 9 provides the necessary receiving earth station parameters for the calculation procedure, which is described in § 2.1 of Annex 5.

In the case where the unknown receiving earth station operates with non-geostationary satellites, the horizon antenna gain to be used for all azimuths is provided in Table 9. The tabulated values were determined by using the method described in § 2.2 of the main body of this Appendix, which uses the maximum and minimum values of horizon antenna gain. For this purpose the maximum horizon antenna gain is the gain of the antenna for an off-axis angle equal to the minimum operating elevation angle. The minimum horizon antenna gain is the gain at large off-axis angles, usually more than  $36^\circ$  or  $48^\circ$ .

In determining the TIG horizon antenna gain entries in Table 9, the difference between the maximum and minimum horizon antenna gain did not exceed 30 dB. Consequently, the TIG horizon antenna gain was taken as the lesser of the maximum horizon antenna gain or 20 dB more than the minimum horizon antenna gain. For the purpose of determining the TIG horizon antenna gain, the reference antenna pattern of § 3 of Annex 3 was used, except in cases noted in the Tables where a different pattern was deemed to be more appropriate.

TABLE 7a (Rev. WRC-12)

Parameters required for the determination of coordination distance for a transmitting earth station

Transmitting space radiocommunication service designation	Mobile-satellite, space operation	Earth exploration-satellite, meteorological satellite	Space operation	Space research, space operation	Mobile-satellite	Space operation	Mobile-satellite, radio-determination-satellite	Mobile-satellite	Space operation, space research	Mobile-satellite	Space research, space operation, Earth exploration-satellite
Frequency bands (MHz)	148.0-149.9	401-403	433.75-434.25	449.75-450.25	806-840	1427-1429	1 610-1 626.5	1 668.4-1 675	1 750-1 850	1 980-2 025	2 025-2 110 2 110-2 120 (Deep-space)
Receiving service designations	Fixed, mobile	Meteorological aids	Amateur, radiolocation fixed, mobile	Fixed, mobile, radio-location	Fixed, mobile broadcasting, aeronautical radionavigation	Fixed, mobile	Aeronautical radionavigation	Fixed, mobile	Fixed, mobile	Fixed, mobile	Fixed, mobile
Method to be used	§ 2.1, § 2.2	§ 2.1, § 2.2	§ 2.1, § 2.2	§ 2.1, § 2.2	§ 1.4, 6	§ 2.1, § 2.2	§ 1.4, 6	§ 1.4, 6	§ 2.1, § 2.2	§ 1.4, 6	§ 2.1, § 2.2
Modulation at terrestrial station 1	A	A N		A and N	A and N	A N	A N	A N	A N	A N	A
Terrestrial station interference parameters and criteria	$f_0$ (%) N $P$ (%) $N_f$ (dB) $M_f$ (dB) $W$ (dB) $G_e$ (dBi) 3 $T_e$ (K) B (Hz) Permissible interference power			0.01 2 0.005 0 20 0 16 750 $12.5 \times 10^3$ -139	0.01 2 0.005 0 20 0 16 750 $12.5 \times 10^3$ -139	0.01 2 0.005 0 33 0 33 750 $4 \times 10^3$ -131	0.01 2 0.005 0 33 0 33 750 $4 \times 10^3$ -131	0.01 2 0.005 0 33 0 33 750 $4 \times 10^3$ -131	0.01 2 0.005 0 33 0 33 750 $4 \times 10^3$ -131	0.01 2 0.005 0 33 0 33 750 $4 \times 10^3$ -131	0.01 2 0.005 0 33 0 33 750 $4 \times 10^3$ -140

1 A: analogue modulation; N: digital modulation.  
 2 The parameters for the terrestrial station associated with transhorizon systems have been used. Line-of-sight radio-relay parameters associated with the frequency band 1 668.4-1 675 MHz may also be used to determine a supplementary contour. (WRC-03)  
 3 Feeder losses are not included.

TABLE 7b (Rev.WRC-15)

Parameters required for the determination of coordination distance for a transmitting earth station

Transmitting space radio communication service designation	Fixed-satellite, mobile-satellite	Acronautical mobile-satellite (R) service	Acronautical mobile-satellite (R) service	Acronautical mobile-satellite (R) service	Fixed-satellite	Fixed-satellite	Fixed-satellite	Earth exploration-satellite, space operation, space research	Fixed-satellite, mobile-satellite, meteorological-satellite	Fixed-satellite	Fixed-satellite	Fixed-satellite	Fixed-satellite 3	Fixed-satellite 3
Frequency bands (GHz)	2.652-2.690	5.030-5.091	5.030-5.091	5.091-5.150	5.725-5.850	5.725-7.075	7.100-7.250 <sup>5</sup>	7.990-8.400	10.7-11.7	12.5-14.8	13.75-14.3	15.4-15.65	17.7-18.4	19.3-19.7
Receiving service designations	Fixed terrestrial mobile	Acronautical mobile-radio navigation	Acronautical mobile-radio navigation	Acronautical mobile (R)	Radio-location	Fixed, mobile	Fixed, mobile	Fixed, mobile	Fixed, mobile	Fixed, mobile	Radio-location radonavigation (land only)	Acronautical radonavigation	Fixed, mobile	Fixed, mobile
Method to be used	§ 2.1, § 2.2	§ 2.1, § 2.2	§ 2.1, § 2.2	§ 2.1	§ 2.1	§ 2.1	§ 2.1, § 2.2	§ 2.1	§ 2.1	§ 2.1, § 2.2	§ 2.1	§ 2.1, § 2.2	§ 2.1, § 2.2	§ 2.2
Modulation at terrestrial station 1	A													
Terrestrial station	0.01				0.01	0.005	0.01	0.005	0.01	0.005	0.01	0.005	0.005	0.005
Interference parameters and criteria	$n$				2	2	2	2	2	2	2	2	2	2
	0.005				0.005	0.0025	0.005	0.0025	0.005	0.0025	0.005	0.0025	0.0025	0.0025
	0				0	0	0	0	0	0	0	0	0	0
	26.2				33	37	33	37	33	40	33	40	33	25
	0				0	0	0	0	0	0	0	0	0	0
	49.2	6	10	6	46	46	46	46	46	50	52	52	48	48
Terrestrial station parameters	500.2				750	750	750	750	750	1 500	1 500	1 500	1 100	1 100
Reference bandwidth	$4 \times 10^3$	$150 \times 10^3$	$37.5 \times 10^3$	$150 \times 10^3$	$4 \times 10^3$	$10^6$	$4 \times 10^3$	$10^6$	$4 \times 10^3$	$10^6$	$4 \times 10^3$	$10^6$	$10^6$	$10^6$
Permissible interference power	-140	-160	-157	-160	-131	-103	-131	-103	-131	-128	-98	-128	-98	-113

1 A: analogue modulation; N: digital modulation.  
 2 The parameters for the terrestrial station associated with transhorizon systems have been used. Line-of-sight radio-relay parameters associated with the frequency band 5 725-7 075 MHz may also be used to determine a supplementary contour with the exception that  $G_s = 37$  dB.  
 3 Feeder links of non-geostationary satellite systems in the mobile-satellite service.  
 4 Feeder losses are not included.  
 5 Actual frequency bands are 7 190-7 250 MHz for the Earth exploration-satellite service, 7 100-7 155 MHz and 7 190-7 235 MHz for the space operation service and 7 145-7 235 MHz for the space research service.

TABLE 7c (Rev.WRC-19)  
Parameters required for the determination of coordination distance for a transmitting earth station

Transmitting space radiocommunication service designation	Fixed-satellite	Fixed-satellite	Fixed-satellite	Fixed-satellite 2	Fixed-satellite	Space research	Earth exploration-satellite, space research	Fixed-satellite, mobile-satellite, radionavigation-satellite	Fixed-satellite 2	Fixed-satellite
Frequency bands (GHz)	24,65-25,25 27,0-29,5	24,65-25,25 27-27,5	28,6-29,1	27,5-28,6 29,1-29,5 <sup>3</sup>	34,2-34,7	40,0-40,5	42,5-47 47,2-50,2 50,4-51,4	47,2-50,2	51,4-52,4	
Receiving service designations	terrestrial	Fixed (HAPS ground station)	Fixed, mobile	Fixed, mobile	Fixed, mobile, radiolocation	Fixed, mobile	Fixed, mobile, radionavigation	Fixed, mobile	Fixed, mobile	
Method to be used	§ 2.1	§ 2.1	§ 2.2	§ 2.2	§ 2.2	§ 2.1, § 2.2	§ 2.1, § 2.2	§ 2.2	§ 2.1	
Modulation at terrestrial station 1	N	N	N	N	N	N	N	N	N	
Terrestrial station interference parameters and criteria	0,005	0,01	0,005	0,005		0,005	0,005	0,001	0,005	
$P_0$ (%)	1	1	2	1		1	1	1	1	
$N_f$ (dB)	0,005	0,005	0,0025	0,005		0,005	0,005	0,001	0,005	
$N_L$ (dB)	0	0	0	0		0	0	0	0	
$M_f$ (dB)	25	10	25	25		25	25	25	25	
$W$ (dB)	0	0	0	0		0	0	0	0	
Terrestrial station $G_s$ (dB) <sup>4</sup>	50	0 <sup>5</sup>	50	50		42	42	46	42	
$T_e$ (K)	2,000	350	2,000	2,000		2,600	2,600	2,000	2,600	
Reference bandwidth $B$ (Hz)	10 <sup>6</sup>	10 <sup>6</sup>	10 <sup>6</sup>	10 <sup>6</sup>		10 <sup>6</sup>	10 <sup>6</sup>	10 <sup>6</sup>	10 <sup>6</sup>	
Permissible interference power in $B$	-111	-134	-111	-111		-110	-110	-111	-110	

1 A: analogue modulation; N: digital modulation.  
 2 Non-geostationary satellites in the fixed-satellite service.  
 3 Feeder links to non-geostationary-satellite systems in the mobile-satellite service.  
 4 Feeder losses are not included.  
 5 Maximum HAPS ground station antenna gain toward the horizon.

TABLE 8a (Rev. WRC-12)

Parameters required for the determination of coordination distance for a receiving earth station

Receiving space radocommunication service designation	Space operation, space research	Meteorological-satellite, mobile-satellite	Space research, space operation	Space operation	Mobile-satellite	Meteorological-satellite	Mobile-satellite	Space research	Space operation	Meteorological-satellite	Broad-casting-satellite	Mobile-satellite	Broadcasting-satellite (DAB)	Mobile-satellite, land-mobile satellite, maritime mobile-satellite
Frequency bands (MHz)	137-138	137-138	143.6-145.65	174-184	163-167 272-273.3	335.4 399.9	400.15-401	400.15-401	401-402	460-470	620-790	856-890	1 452-1 492	1 318-1 530 1 555-1 559 2 160-2 200.1
Transmitting service designations	Fixed, mobile	Fixed, mobile	Fixed, mobile, radio-location	Fixed, mobile, broad-casting	Fixed, mobile	Fixed, mobile	Meteorological-aids	Meteorological-aids	Meteorological-aids, fixed, mobile	Fixed, mobile	Fixed, mobile, broad-casting	Fixed, mobile, broad-casting	Fixed, mobile, broadcasting	Fixed, mobile
Method to be used	§ 2.1	§ 2.1	§ 2.1	§ 2.1	§ 2.1	§ 1.4.6	§ 1.4.6	§ 1.4.6	§ 2.1	§ 2.1	§ 1.4.5	§ 1.4.6	§ 1.4.5	§ 1.4.6
Modulation at earth station 2	N	N	N	N	N				N	N			N	N
Earth station	0.1		0.1		1.0	0.012	0.1	0.1	0.1	0.012				10
Interference parameters	2		2		1	1	2	2	2	1				1
Criteria	0.05		0.05		1.0	0.012	0.05	0.05	0.05	0.012				10
$N_L$ (dB)	0		0		0	0	0	0	0	0				0
$M_f$ (dB)	1		1		1	4.3	1	1	1	1				1
$\beta$ (dB)	0		0		0	0	0	0	0	0				0
Terrestrial station	A		-		15		-	-	-	5			38	37.4
$E$ (dBW) in $B$ 3	N		-		15		-	-	-	5			38	37
$P_T$ (dBW) in $B$	A		-		-1		-	-	-	-1			3	0
$G_x$ (dB)	N		-		-1		-	-	-	-1			3	0
Reference bandwidth					16					16				37
$f$ (Hz)	1		1		10 <sup>3</sup>					85				2.5 × 10 <sup>3</sup>
Permissible interference power	-199		-199		-173					-148				4 × 10 <sup>3</sup>
										-208				-176

1 In the band 2 160-2 200 MHz, the terrestrial station parameters of line-of-sight radio-relay systems have been used. If an administration believes that, in this band transhorizon systems need to be considered, the parameters associated with the frequency band 2 500-2 690 MHz may be used to determine the coordination area.

2 A: analogue modulation; N: digital modulation.

3  $E$  is defined as the equivalent isotropically radiated power of the interfering terrestrial station in the reference bandwidth.

4 This value is reduced from the nominal value of 50 dBW for the purposes of determination of coordination area, recognizing the low probability of high power emissions falling fully within the relatively narrow bandwidth of the earth station.

5 The fixed-service parameters provided in the column for 163-167 MHz and 272-273 MHz are only applicable to the band 163-167 MHz.



TABLE 8b (Rev. WRC-12)

Parameters required for the determination of coordination distance for a receiving earth station

Receiving space radiocommunication service designation	Space operation (GSO and non-GSO)	Meteorological-satellite (non-GSO)	Meteorological-satellite (GSO)	Space research near-Earth (non-GSO and GSO)	Space research deep space (non-GSO)	Space operation (non-GSO and GSO)	Earth exploration-satellite (GSO)	Broadcasting-satellite	Mobile-satellite, radio-determination-satellite	Fixed-satellite, broadcasting-satellite	Fixed-satellite
Frequency bands (GHz)	1.525-1.535	1.670-1.710	1.670-1.710	Unmanned 1.700-1.710 Manned 2.200-2.290	2.290-2.300	2.200-2.290	2.200-2.290	2.310-2.360	2.4835-2.500 <sup>6</sup>	2.500-2.690	3.400-4.200
Transmitting service designations	Fixed	Fixed, mobile, meteorological aids	Fixed, mobile, meteorological aids	Fixed, mobile	Fixed, mobile	Fixed, mobile	Fixed, mobile	Fixed, mobile, radiolocation	Fixed, mobile, radiolocation	Fixed, mobile radiolocation	Fixed, mobile
Method to be used	§ 2.1.1, § 2.2	§ 2.2 and 1	§ 2.1 and 1	§ 2.1, § 2.2	§ 2.2	§ 2.1, § 2.2	§ 2.1	§ 1.4.5	§ 1.4.6	§ 1.4.5 and § 2.1	§ 2.1
Modulation at earth station <sup>2</sup>	N	N	N	N	N	N	N	A	N	A	A
Earth station parameters and criteria	$P_0$ (%) $n$	0.006 3 2	0.011 0 2	0.1 2 0.001	0.001 1 0.001	1.0 2 0.5	1.0 2 0.5	0.03 3 0.01	10 1 10	0.03 0.003 0.001	0.03 0.003 0.01
Terrestrial station parameters	$E$ (dBW) in $B$ <sup>3</sup>	50 92.4	92.4	-27 4.5	-27 4.5	72 76	72.4 76	72.4 76	37 37	72.4 76	72.4 76
	$P_1$ (dBW) in $B$	13	40.4	-71 4.5	-71 4.5	28	28.4	28.4	0	28.4	28.4
	$G_x$ (dBi)	37	52	44	44	44	44	44	37	44	44
Reference bandwidth	$B$ (Hz)	$10^3$	$4 \times 10^3$	1	1	$10^6$	$10^6$	$10^6$	$4 \times 10^3$	$10^6$	$10^6$
Permissible interference power	$P_1(p)$ (dBW) in $B$	-184	-142	-216	-222	-154	-154	-154	-176	$10^6$	$10^6$

1 See Table 10.

2 A: analogue modulation; N: digital modulation.

3  $E$  is defined as the equivalent isotropically radiated power of the interfering terrestrial station in the reference bandwidth.

4 In this band, the parameters for the terrestrial stations associated with transhorizon systems have been used. If an administration believes that transhorizon systems do not need to be considered, the line-of-sight radio-relay parameters associated with the frequency band 3.4-4.2 GHz may be used to determine the coordination area, with the exception that  $E = 50$  dBW for analogue terrestrial stations; and  $G_x = 37$  dBi. However, for the space research service only, noting footnote 5 when transhorizon systems are not considered,  $E = 20$  dBW and  $P_1 = 17$  dBW for analogue terrestrial stations,  $E = -23$  dBW and  $P_1 = -60$  dBW for digital terrestrial stations; and  $G_x = 37$  dBi.

5 These values are estimated for 1 Hz bandwidth and are 30 dB below the total power assumed for emission.

6 In the band 2.4835-2.5 GHz the terrestrial station parameters of line-of-sight radio-relay systems have been used. If an administration believes that, in this band, transhorizon systems need to be considered, the parameters associated with the frequency band 2.500-2.690 MHz may be used to determine the coordination area.

TABLE 8c (Rev.WRC-15)  
Parameters required for the determination of coordination distance for a receiving earth station

Receiving space radio communication service designation	Fixed-satellite	Fixed-satellite, determination satellite	Fixed-satellite	Meteorological-satellite 7, 8	Meteorological-satellite 9	Earth exploration-satellite 7	Earth exploration-satellite 9	Space research 10	Fixed-satellite		Broadcasting-satellite	Fixed-satellite 7
									Fixed-satellite	Broadcasting-satellite		
Frequency bands (GHz)	4.500-4.800	5.150-5.216	6.700-7.075	7.450-7.550	7.750-7.900	8.025-8.400	8.025-8.400	8.400-8.450 8.450-8.500	10.7-12.75 13.4-13.657	12.5-12.7512	17.7-17.8	17.7-18.8 19.3-19.7
Transmitting terrestrial service designations	Fixed, mobile	Aeronautical radionavigation	Fixed, mobile	Fixed, mobile	Fixed, mobile	Fixed, mobile	Fixed, mobile	Fixed, mobile	Fixed, mobile	Fixed, mobile	Fixed	Fixed, mobile
Method to be used	§ 2.1	§ 2.1	§ 2.2	§ 2.1, § 2.2	§ 2.2	§ 2.1	§ 2.2	§ 2.2	§ 2.1, § 2.2	§ 1.4.5	§ 1.4.5	§ 2.1
Modulation at earth station 1	A	N	N	N	N	N	N	N	A	N	A	N
Earth station interference parameters and criteria	0.03	0.005	0.005	0.002	0.001	0.083	0.011	0.001	0.03	0.003	0.03	0.003
$P_0$ (%)	3	3	3	2	2	2	2	1	2	2	1	1
$P_1$ (%)	0.01	0.0017	0.01	0.0017	0.0005	0.0415	0.0055	0.001	0.05	0.015	0.03	0.0015
$N_L$ (dB)	1	1	1	1	1	1	0	0	0	1	1	1
$M_d$ (dB)	7	2	7	2	—	2	4.7	0.5	1	7	4	7
$W$ (dB)	4	0	0	4	0	0	0	0	0	4	0	0
Terrestrial station	A	92.3	55	55	55	55	55	25.5	40	40	55	55
$E$ (dBW)	N	42.4	42	42	42	42	42	-18	-18	43	42	40
Parameters	A	40 <sup>3</sup>	13	13	13	13	13	-17 <sup>5</sup>	-5	-5	10	10
$P_1$ (dBW) in B	N	0	0	0	0	0	0	-60	-2	-2	-3	-7
$G_2$ (dBi)	52.3-4	52.3-4	42	42	42	42	42	42	42	45	45	47
Reference band-width <sup>6</sup>	10 <sup>6</sup>	10 <sup>6</sup>	10 <sup>6</sup>	10 <sup>7</sup>	10 <sup>7</sup>	10 <sup>6</sup>	10 <sup>6</sup>	1	1	10 <sup>6</sup>	27 × 10 <sup>6</sup>	27 × 10 <sup>6</sup>
Permissible interference power		-151.2		-125	-125	-154.11	-142	-220	-2.16	-131	-131	

Notes to Table 8c:

- 1 A: analogue modulation; N: digital modulation.
- 2  $E$  is defined as the equivalent isotropically radiated power of the interfering terrestrial station in the reference bandwidth.
- 3 In this band, the parameters for the terrestrial stations associated with transhorizon systems have been used. If an administration believes that transhorizon systems do not need to be considered, the line-of-sight radio-relay parameters associated with the frequency band 3.4-4.2 GHz may be used to determine the coordination area.
- 4 Digital systems assumed to be non-transhorizon. Therefore  $G_r = 42.0$  dBi. For digital transhorizon systems, parameters for analogue transhorizon systems above have been used.
- 5 These values are estimated for 1 Hz bandwidth and are 30 dB below the total power assumed for emission.
- 6 In certain systems in the fixed-satellite service, it may be desirable to choose a greater reference bandwidth  $B$ . However, a greater bandwidth will result in smaller coordination distances and a later decision to reduce the reference bandwidth may require recoordination of the earth station.
- 7 Geostationary-satellite systems.
- 8 Non-geostationary satellites in the meteorological-satellite service notified in accordance with No. 5.461A may use the same coordination parameters.
- 9 Non-geostationary satellite systems.
- 10 Space research earth stations in the frequency band 8.4-8.5 GHz operate with non-geostationary satellites.
- 11 For large earth stations:  $P_e(p) = (G - 180)$  dBW  
 For small earth stations:  $P_e(20\%) = 2(G - 26) - 140$  dBW for  $26 < G \leq 29$  dBi  
 $P_e(20\%) = G - 163$  dBW for  $G > 29$  dBi  
 $P_e(p)\% = G - 163$  dBW for  $G \leq 26$  dBi
- 12 Applies to the broadcasting-satellite service in unplanned bands in Region 3.

TABLE 8d (Rev.WRC-19)  
Parameters required for the determination of coordination distance for a receiving earth station

Receiving space radiocommunication service designation	Meteorological-satellite	Fixed-satellite	Fixed-satellite, 3	Broadcasting-satellite	Earth exploration-satellite, 4	Earth exploration-satellite, 5	Space research		Fixed-satellite, 6	Fixed-satellite, 5	Mobile-satellite	Broadcasting-satellite, fixed-satellite	Mobile-satellite	Radio-navigation-satellite
							Unmanned	Manned						
Frequency bands (GHz)	18.0-18.4	17.8-18.6 <sup>4</sup>	19.3-19.7	21.4-22.0	25.5-27.0	25.5-27.0	31.8-32.3	37.0-38.0	37.5-40.5	37.5-40.5	39.5-40.5	40.5-42.5	43.5-47.0	43.5-47.0
Transmitting terrestrial service designations	Fixed, mobile	Fixed, mobile	Fixed, mobile	Fixed, mobile	Fixed, mobile	Fixed, mobile	Fixed, radio-navigation	Fixed, mobile	Fixed, mobile	Fixed, mobile	Fixed, mobile	Broadcasting, fixed	Mobile	Mobile
Method to be used	§ 2.1	§ 2.1, § 2.2	§ 2.2	§ 1.4.5	§ 2.2	§ 2.1	§ 2.1, § 2.2	§ 2.1, § 2.2	§ 2.2	§ 2.1	§ 1.4.6	§ 1.4.5, § 2.1	§ 1.4.6	—
Modulation at earth station 1	N	N	N	N	N	N	N	N	N	N	N	—	N	—
Earth station parameters and criteria	$p_0$ (%)	0.003	0.01	—	0.25	0.25	0.001	0.1	0.001	0.02	0.003	—	—	—
$n$	2	2	1	—	2	2	1	1	1	—	2	—	—	—
$P_f$ (%)	0.025	0.0015	0.01	0.125	0.125	0.125	0.001	0.1	0.001	0.0015	—	—	—	—
$N_f$ (dB)	0	0	0	0	0	0	0	0	0	1	—	—	—	—
$M_f$ (dB)	18.8	5	5	11.4	14	14	1	1	6.8	6	—	—	—	—
$H_f$ (dB)	0	0	0	0	0	0	0	0	0	0	—	—	—	—
Terrestrial station parameters	$E_f$ (dBW) in $B$	—	—	—	—	—	—	—	—	—	—	—	—	—
$P_f$ (dBW) in $B$	N	40	40	40	42	42	-28	-28	35	35	44	40	40	40
$G_f$ (dB)	N	-7	-7	-7	-3	-3	-81	-73	-10	-10	-1	-7	-7	-7
Reference bandwidth 7	$B$ (Hz)	47	47	47	45	45	53	45	45	45	45	45	47	47
Permissible interference power	$P_f(P)$ (dBW) in $B$	10 <sup>6</sup>	10 <sup>6</sup>	10 <sup>7</sup>	10 <sup>7</sup>	10 <sup>7</sup>	1	1	10 <sup>6</sup>	10 <sup>6</sup>	10 <sup>6</sup>	10 <sup>6</sup>	—	—
		-140	-137	-120	-116	-116	-216	-217	-140	-140	-140	-140	-140	-140

1 A: analogue modulation; N: digital modulation.  
 2  $E_f$  is defined as the equivalent isotropically radiated power of the interfering terrestrial station in the reference bandwidth.  
 3 Non-geostationary mobile-satellite service feeder links.  
 4 Non-geostationary-satellite systems.  
 5 Geostationary-satellite systems.  
 6 Non-geostationary fixed-satellite service systems.  
 7 In certain systems in the fixed-satellite service it may be desirable to choose a greater reference bandwidth  $B$ . However, a greater bandwidth will result in smaller coordination distances, and a later decision to reduce the reference bandwidth may require recoordination of the earth station.

TABLE 9a (Rev.WRC-19)  
**Parameters required for the determination of coordination distance for a transmitting earth station in bands shared bidirectionally with receiving earth stations**

Space service designation in which the transmitting earth station operates	Mobile-satellite	Earth exploration-satellite, meteorological-satellite	Mobile-satellite	Fixed-satellite, mobile-satellite	Aeronautical mobile-satellite (R) service	Fixed-satellite, 3	Fixed-satellite	Fixed-satellite, meteorological-satellite	Fixed-satellite
Frequency bands (GHz)	0.272-0.273	0.401-0.402	1.670-1.675	2.655-2.690	5.030-5.091	5.150-5.216	6.700-7.075	8.025-8.400	8.025-8.400
Space service designation in which the receiving earth station operates	Space operation	Space operation	Meteorological-satellite	Fixed-satellite, broadcasting-satellite	Aeronautical mobile-satellite (R) service	Fixed-satellite	Fixed-satellite	Earth exploration-satellite	Earth exploration-satellite
Orbit 6	Non-GSO	Non-GSO	Non-GSO	Non-GSO	Non-GSO	Non-GSO	Non-GSO	Non-GSO	GSO
Modulation at receiving earth station 1	N	N	N	N			N	N	N
Receiving earth station	1.0	0.1	0.006	0.011			0.005	0.011	0.083
interference parameters	1	2	3	2			3	2	2
and criteria	1.0	0.05	0.002	0.0055			0.0017	0.0055	0.0415
$N_f$ (dB)	0	0	0	0			1	0	1
$M_f$ (dB)	1	1	2.8	0.9		2	2	4.7	2
$W$ (dB)	0	0	0	0			0	0	0
Receiving earth station parameters	20	20	30	45	45	48.5	50.7		
$G_m$ (dB) 2	19	19	19.9	8	8	10	10	10	8
$G_r$ (dB) 4	10°	10°	5°	3°	10°	3°	3°	5°	3°
$\epsilon_{min}$ 5	500	500	370	118	340	75	75		
$T_e$ (K) 7	10 <sup>3</sup>	1	10 <sup>6</sup>	4 × 10 <sup>3</sup>	37.5 × 10 <sup>3</sup>	10 <sup>6</sup>	10 <sup>6</sup>	10 <sup>6</sup>	10 <sup>6</sup>
Reference bandwidth	-177	-208	-145	-178	-163.5	-163.5	-151	-142	-154
Permissible interference power									

## Notes to Table 9a:

- 1 A: analogue modulation; N: digital modulation.
- 2 On-axis gain of the receive earth station antenna.
- 3 Feeder links of non-geostationary-satellite systems in the mobile-satellite service.
- 4 Horizon antenna gain for the receive earth station (refer to § 3 of the main body of this Appendix and to § 3 of this Annex).
- 5 Minimum elevation angle of operation in degrees (non-geostationary or geostationary).
- 6 Orbit of the space service in which the receiving earth station operates (non-geostationary or geostationary).
- 7 The thermal noise temperature of the receiving system at the terminal of the receiving antenna (under clear-sky conditions). Refer to § 2.1 of this Annex for missing values.
- 8 Horizon antenna gain is calculated using the procedure of Annex 5. Where no value of  $G_M$  is specified, a value of 42 dBi is to be used.
- 9 Non-geostationary horizon antenna gain,  $G_e = G_{min} + 20$  dB (see § 2.2), with  $G_{min} = 10 - 10 \log (D/\lambda)$ ,  $D/\lambda = 13$  (refer to Annex 3 for definition of symbols).

TABLE 9b (Rev.WRC-19)  
**Parameters required for the determination of coordination distance for a transmitting earth station in bands shared bidirectionally with receiving earth stations**

Space service designation in which the transmitting earth station operates	Fixed-satellite				Fixed-satellite				Fixed-satellite 3	Fixed-satellite 3	Fixed-satellite 4	Earth exploration-satellite, space research
	10,7-11,7		12,5-12,75		17,3-17,8		17,7-18,4					
Space service designation in which the receiving earth station operates	Fixed-satellite				Fixed-satellite				Fixed-satellite 3	Fixed-satellite 3	Fixed-satellite 4	Fixed-satellite, mobile-satellite
Obt. 7	GSO		Non-GSO		GSO		Non-GSO		Non-GSO	GSO	GSO	Non-GSO
Modulation at receiving earth station 1	A	N	N		A	N	N		N			
Receiving earth station interference parameters and criteria	0,03		0,003		0,03		0,003		0,003		0,003	0,003
$P$ (%)	2		2		2		2		2		2	2
$N_f$ (dB)	0,015		0,0015		0,015		0,0015		0,015		0,0015	0,0015
$M_f$ (dB)	1		1		1		1		1		1	1
$M_f$ (dB)	7		4		7		4		6		6	6
$H$ (dB)	4		0		4		0		0		0	0
Receiving earth station parameters			51,9				31,2		58,6	53,2	49,5	50,8
$G_r$ (dB)	9		10		9		11,11		9		10	9
$\epsilon_{min}$ 6	5°		6°		5°		10°		5°		10°	10°
$T_e$ (K) 8	150		150		150		150		300		300	300
Reference bandwidth	10 <sup>6</sup>		10 <sup>6</sup>		10 <sup>6</sup>		10 <sup>6</sup>		10 <sup>6</sup>	10 <sup>6</sup>	300	
Permissible interference power in $B$	-144		-144		-144		-144		-138		-141	

## Notes to Table 9b:

- 1 A: analogue modulation; N: digital modulation.
- 2 On-axis gain of the receive earth station antenna.
- 3 Feeder links of non-geostationary-satellite systems in the mobile-satellite service.
- 4 Geostationary-satellite systems.
- 5 Horizon antenna gain for the receive earth station (refer to § 3 of the main body of the Appendix and to § 3 of this Annex).
- 6 Minimum elevation angle of operation in degrees (non-GSO or GSO).
- 7 Orbit of the space service in which the receiving earth station operates (GSO or non-GSO).
- 8 The thermal noise temperature of the receiving system at the terminal of the receiving antenna (under clear-sky conditions). Refer to § 2.1 of this Annex for missing values.
- 9 Horizon antenna gain is calculated using the procedure of Annex 5. Where no value of  $G_M$  is specified, a value of 42 dBi is to be used.
- 10 Horizon antenna gain is calculated using the procedure of Annex 5, except that the following antenna pattern may be used in place of that given in § 3 of Annex 3:  $G = 32 - 25 \log \varphi$  for  $1^\circ \leq \varphi < 48^\circ$ ; and  $G = -10$  for  $48^\circ \leq \varphi < 180^\circ$  (refer to Annex 3 for definition of symbols).
- 11 Non-geostationary horizon antenna gain:  $G_e = G_{max}$  (see § 2.2 of the main body of this Appendix) with the antenna pattern modelled by the equation  $G = 36 - 25 \log (\varphi)$  (refer to Annex 3 for definition of symbols).
- 12 Non-geostationary horizon antenna gain:  $G_r = G_{max}$  (see § 2.2 of the main body of this Appendix) with the antenna pattern modelled by the equation  $G = 32 - 25 \log (\varphi)$  (refer to Annex 3 for definition of symbols).



TABLE 10 (Rev.WRC-19)

**Predetermined coordination distances**

Frequency sharing situation		Coordination distance (in sharing situations involving services allocated with equal rights) (km)
Type of earth station	Type of terrestrial station	
Ground-based in the bands below 1 GHz to which No. 9.11A applies. Ground-based mobile in the bands within the range 1-3 GHz to which No. 9.11A applies	Mobile (aircraft)	500
Aircraft (all bands)	Ground-based	500
Aircraft (all bands)	Mobile (aircraft)	1 000
Ground-based in the bands: 400.15-401 MHz 1 668.4-1 675 MHz	Station in the meteorological aids service (radiosonde)	580
Aircraft in the bands: 400.15-401 MHz 1 668.4-1 675 MHz	Station in the meteorological aids service (radiosonde)	1 080
Ground-based in the radiodetermination-satellite service (RDSS) in the bands: 1 610-1 626.5 MHz 2 483.5-2 500 MHz 2 500-2 516.5 MHz	Ground-based	100
Airborne earth station in the radiodetermination-satellite service (RDSS) in the bands: 1 610-1 626.5 MHz 2 483.5-2 500 MHz 2 500-2 516.5 MHz	Ground-based	400
Receiving earth stations in the meteorological-satellite service	Station in the meteorological aids service	The coordination distance is considered to be the visibility distance as a function of the earth station horizon elevation angle for a radiosonde at an altitude of 20 km above mean sea level, assuming 4/3 Earth radius (see Note 1)
Non-GSO MSS feeder-link earth stations (all bands)	Mobile (aircraft)	500
Non-GSO MSS feeder-link earth stations in the band 5 091-5 150 MHz	Station in the aeronautical radionavigation service	Note 2
Receiving earth stations in the space research service in the band: 2 200-2 290 MHz	Mobile (aircraft)	880
Ground-based in the bands in which the frequency sharing situation is not covered in the rows above	Mobile (aircraft)	500

Notes to Table 10:

NOTE 1 – The coordination distance,  $d$  (km), for fixed earth stations in the meteorological-satellite service vis-à-vis stations in the meteorological aids service assumes a radiosonde altitude of 20 km and is determined as a function of the physical horizon elevation angle  $\varepsilon_h$  (degrees) for each azimuth, as follows:

$$\begin{array}{ll}
 d = 100 & \text{for } \varepsilon_h \geq 11^\circ \\
 d = 582 \left( \sqrt{1 + (0.254 \varepsilon_h)^2} - 0.254 \varepsilon_h \right) & \text{for } 0^\circ < \varepsilon_h < 11^\circ \\
 d = 582 & \text{for } \varepsilon_h \leq 0^\circ
 \end{array}$$

The minimum and maximum coordination distances are 100 km and 582 km, and correspond to physical horizon angles greater than  $11^\circ$  and less than  $0^\circ$ . (WRC-2000)

NOTE 2 – For the coordination distance in the frequency band 5 091-5 150 MHz vis-à-vis stations in the aeronautical radionavigation service, see No. **5.444A**. (WRC-15)



## APPENDIX 8 (REV.WRC-15)

## Method of calculation for determining if coordination is required between geostationary-satellite networks sharing the same frequency bands

### 1 Introduction

The method of calculation for determining if coordination is required under provision No. 9.7 is based on the concept that the noise temperature of a system subject to interference increases as the level of the interfering emission increases. It can, therefore, be applied irrespective of the modulation characteristics of these satellite networks, and of the precise frequencies used.

In this method, the apparent increase in the equivalent satellite link noise temperature resulting from an interfering emission of a given system is calculated (see § 2 below) and the ratio of this increase to the equivalent satellite link noise temperature, expressed as a percentage, is compared to a threshold value (see § 3 below).

### 2 Calculation of the apparent increase in equivalent noise temperature of the satellite link subject to an interfering emission

Two possible cases are considered:

*Case I:* wanted and interfering networks share one or more frequency bands, each in the same direction of transmission;

*Case II:* wanted and interfering networks share one or more frequency bands, each in opposite directions of transmission (bidirectional use).

These two cases cover all relative satellite positions from closely-spaced to near-antipodal positions.

#### 2.1 Parameters

Let A be a satellite link of network R associated with satellite S and A' be a satellite link of network R' associated with satellite S'. The symbols relating to satellite link A' bear primes, those relating to satellite link A do not bear primes.

The parameters are defined as follows (for satellite link A):

$T$ : the equivalent satellite link noise temperature, referred to the output of the receiving antenna of the earth station (K);

$T_s$ : the receiving system noise temperature of the space station, referred to the output of the receiving antenna of the space station (K);

$T_e$ : the receiving system noise temperature of the earth station, referred to the output of the receiving antenna of the earth station (K);

$\Delta T_s$ : apparent increase in the receiving system noise temperature of the satellite S, caused by an interfering emission, referred to the output of the receiving antenna of this satellite (K);

$\Delta T_e$ : apparent increase in the receiving system noise temperature of the earth station  $e_R$ , caused by an interfering emission, referred to the output of the receiving antenna of this station (K);

## AP8-2

$p_s$  : maximum power density per Hz delivered to the antenna of satellite S (averaged over the worst 4 kHz band for a carrier frequency below 15 GHz or over the worst 1 MHz band above 15 GHz) (W/Hz);

$g_3(\eta)$  : transmitting antenna gain of satellite S in the direction  $\eta$  (numerical power ratio);

$\eta_A$  : direction, from satellite S, of the receiving earth station  $e_R$  of satellite link A;

$\eta_{e'}$  : direction, from satellite S, of the receiving earth station  $e'_R$  of satellite link A';

NOTE – The product  $p_s g_3(\eta_{e'})$  is the maximum e.i.r.p. per Hz of satellite S in the direction of the receiving earth station  $e'_R$  of satellite link A'.

$\eta_{s'}$  : direction, from satellite S, of satellite S';

$p_e$  : maximum power density per Hz delivered to the antenna of the transmitting earth station  $e_T$  (averaged over the worst 4 kHz band for a carrier frequency below 15 GHz or over the worst 1 MHz band above 15 GHz) (W/Hz);

$g_2(\delta)$  : receiving antenna gain of satellite S in the direction  $\delta$  (numerical power ratio);

$\delta_A$  : direction, from satellite S, of the transmitting earth station  $e_T$  of satellite link A;

$\delta_{e'}$  : direction, from satellite S, of the transmitting earth station  $e'_T$  of satellite link A';

$\delta_{s'}$  : direction, from satellite S, of satellite S';

$\theta_t$  : topocentric angular separation in degrees between the two satellites<sup>1</sup>, taking the longitudinal station-keeping tolerances into account;

NOTE – Only the topocentric angle  $\theta_t$  should be used in dealing with Case I.

$\theta_g$  : geocentric angular separation in degrees between the two satellites, taking the longitudinal station-keeping tolerances into account;

NOTE – Only the geocentric angle  $\theta_g$  should be used in dealing with Case II.

$g_1(\theta_t)$  : transmitting antenna gain of the earth station  $e_T$  in the direction of satellite S' (numerical power ratio);

$g_4(\theta_t)$  : receiving antenna gain of the earth station  $e_R$  in the direction of satellite S' (numerical power ratio);

$k$  : Boltzmann's constant ( $1.38 \times 10^{-23}$  J/K);

---

<sup>1</sup> A method for calculation of the topocentric angular separation is given in Annex I.

$l_d$  : free-space transmission loss<sup>2</sup> on the downlink (numerical power ratio), evaluated from satellite S to the receiving earth station  $e_R$  for satellite link A;

NOTE – The free-space transmission loss on any downlink evaluated from the satellites S or S' to the receiving earth stations  $e_R$  or  $e'_R$  is considered to be equal to  $l_d$ .

$l_u$  : free-space transmission loss<sup>2</sup> on the uplink (numerical power ratio), evaluated from the earth station  $e_T$ , to satellite S for satellite link A;

NOTE – The free-space loss on any uplink evaluated from the earth stations  $e_T$  or  $e'_T$  to the satellite S or S' is considered to be equal to  $l_u$ .

$l_s$  : free-space transmission loss<sup>2</sup> on the inter-satellite link (numerical power ratio), evaluated from satellite S' to satellite S;

$\gamma$  : transmission gain of a specific satellite link subject to interference evaluated from the output of the receiving antenna of satellite S to the output of the receiving antenna of the earth station  $e_R$  (numerical power ratio, usually less than 1).

## 2.2 General method

In the following equations, the frequency to be used for the calculation of  $l_d$ ,  $l_u$ , and  $l_s$  is the average frequency of the band common to both networks in the direction considered. If, in a given direction, there is no overlap of the assigned frequency bands of the two networks, the corresponding value ( $\Delta T_s$  or  $\Delta T_e$ ) is taken to be equal to zero. For cases where the Appendix 4 data have not been published, the assigned frequency band for that network shall be considered as being the frequency range as provided for in Appendix 4.

### 2.2.1 Case I – Wanted and interfering networks sharing the same frequency band in the same direction of transmission

The gains  $g_1(\theta_i)$  and  $g_4(\theta_i)$  are those of the earth stations concerned. When neither measured data nor a relevant ITU-R Recommendation accepted by the administrations concerned are available the radiation patterns set out in Annex III should be used.

#### 2.2.1.1 Simple frequency-changing transponder on board the satellite

The parameters  $\Delta T_s$  and  $\Delta T_e$  are given by the following equations:

$$\Delta T_s = \frac{p'_e g'_1(\theta_i) g_2(\delta_{e'})}{k l_u} \quad (1)$$

$$\Delta T_e = \frac{p'_s g'_3(\eta_e) g_4(\theta_i)}{k l_d} \quad (2)$$

The symbol  $\Delta T$  will be used to denote the apparent increase in the equivalent noise temperature for the entire satellite link referred to the output of the receiving antenna of the receiving earth station  $e_R$  due to the interfering emission from link A'.

This increase is the result of the interfering emissions entering at both the satellite and the earth station receiver of link A and can accordingly be expressed as:

$$\Delta T = \gamma \Delta T_s + \Delta T_e \quad (3)$$

<sup>2</sup> A method for calculation of the free-space transmission loss is given in Annex II.

Hence,

$$\Delta T = \gamma \frac{p'_e g'_1(\theta_t) g_2(\delta_{e'})}{kl_u} + \frac{p'_s g'_3(\eta_e) g_4(\theta_t)}{kl_d} \quad (4)$$

An example calculation for the application of the method of this Appendix in Case I is given in Annex IV.

In the same way, the increase  $\Delta T'$  in the equivalent noise temperature for the entire satellite link, referred to the output of the receiving antenna of the receiving earth station  $e'_R$ , under the effect of the interference caused by satellite link A, is given by the following equations:

$$\Delta T'_{s'} = \frac{p_e g_1(\theta_t) g'_2(\delta_e)}{kl_u} \quad (5)$$

$$\Delta T'_{e'} = \frac{p_s g_3(\eta_{e'}) g'_4(\theta_t)}{kl_d} \quad (6)$$

$$\Delta T' = \gamma \frac{p_e g_1(\theta_t) g'_2(\delta_e)}{kl_u} + \frac{p_s g_3(\eta_{e'}) g'_4(\theta_t)}{kl_d} \quad (7)$$

### 2.2.1.2 Cases requiring independent treatment of the uplink and the downlink

If there is a change of modulation in the satellite, if the transmission gain for the satellite network being considered has not been supplied, or if the transmission originates on board the satellite, then the apparent increase in the noise temperature must be related to the total receiving system noise temperature of the specific link being examined (the space station or the earth station, whichever is applicable). In this case, the equivalent noise temperature of the entire satellite link and the transmission gain are not used and equations (1) and (2) above are used separately as required (see § 3.2). (WRC-03)

### 2.2.2 Case II – Wanted and interfering networks sharing the same frequency band in opposite directions of transmission (bidirectional use)

The calculation method below only applies to interfering emissions between satellites.

Interference between earth stations using the same frequency band in opposite directions of transmission (bidirectional use) is to be dealt with by coordination procedures analogous to those used for coordination between earth and terrestrial stations.

All the equations relating to Case II shall use the geocentric angle  $\theta_g$ .

#### 2.2.2.1 Simple frequency-changing transponder on board the satellite

The noise temperature increase  $\Delta T_s$  referred to the output of the receiving antenna of the satellite of link A is given by:

$$\Delta T_s = \frac{p'_s g'_3(\eta_s) g_2(\delta_{s'})}{kl_s} \quad (8)$$

The apparent increase in equivalent link noise temperature is then given by:

$$\Delta T = \gamma \Delta T_s \quad (9)$$

The increase  $\Delta T'$  in the equivalent noise temperature of the link A' caused by interfering emissions from the satellite associated with the link A is given by:

$$\Delta T' = \gamma' \Delta T'_s = \frac{\gamma' p_s g_3 (\eta_{s'}) g_2' (\delta_s)}{k l_s} \tag{10}$$

**2.2.2.2 Cases requiring independent treatment of the uplink and downlink**

In this case equation (8) is used directly with  $T_s$  to obtain the percentage increase. The increase  $\Delta T'_s$  in the noise temperature of link A' caused by interfering emissions from the satellite associated with link A is obtained in a similar manner.

**2.2.3 Consideration of polarization isolation**

The polarization isolation factor described in this paragraph shall be considered only if the administration responsible for each network has consented to such a course and has notified its polarization or published it for coordination under No. 9.7. In this case, the apparent increase in the equivalent satellite link noise temperature shall be determined by the following expressions:

Case I 
$$\Delta T = \frac{\gamma \Delta T_s}{Y_u} + \frac{\Delta T_e}{Y_d}$$

Case II 
$$\Delta T = \frac{\gamma \Delta T_s}{Y_{ss}}$$

where the values of  $\Delta T_s$  and  $\Delta T_e$  are those given in § 2.2.1 and § 2.2.2 and the values of the factors of polarization isolation  $Y_u$ ,  $Y_d$  and  $Y_{ss}$  are those given in the Table below.

Polarization		Factor of polarization isolation (numerical ratio) $Y$
Network R	Network R'	
LHC	RHC	4
LHC	L	1.4
RHC	L	1.4
LHC	LHC	1
RHC	RHC	1
L	L	1

Where:

LHC: left-hand circular (anti-clockwise)  
 RHC: right-hand circular (clockwise)  
 L: linear

**2.3 Determination of the satellite links to be considered in calculating the increase in equivalent satellite link noise temperature (Case I only)**

The greatest increase in equivalent satellite link noise temperature caused to any link of another satellite network, existing or planned, by interfering emissions of the proposed satellite network must be determined.



The most unfavourably sited transmitting earth station of the interfering satellite network should be determined for each satellite receiving antenna of the network subject to interference by superimposing the “Earth-to-space” service areas of the interfering network on the space station receiving antenna gain contours plotted on a map of the Earth’s surface. The most unfavourably sited transmitting earth station is the one in the direction of which the satellite receiving antenna gain of the network subject to interference is the greatest.

The most unfavourably sited receiving earth station of the network subject to interference should be determined in an analogous manner for each “space-to-Earth” service area of that network. The most unfavourably sited receiving earth station is the one in the direction of which the satellite transmitting antenna gain of the interfering network is the greatest.

**2.4 Use of information furnished under Appendix 4**

When an administration elects to use information furnished under Appendix 4 with the calculation procedures of § 2.2.1.1 and § 2.2.2.1 in order to formulate comments, the calculations need to be made for both sets of values of  $\gamma$  and  $T$  furnished. The greater of the two values of  $\Delta T/T$  resulting from these calculations is the one to be used. (WRC-15)

**3 Comparison between calculated percentage increase in noise temperature and the threshold value**

**3.1 Simple frequency-changing transponder on board the satellite**

The calculated values of the  $\Delta T/T$  and  $\Delta T'/T$ , expressed as percentages, shall be compared with the threshold value of 6%<sup>3</sup>.

- If the calculated value of  $\Delta T/T$ , expressed as a percentage, due to any interfering emission from satellite link A' to satellite link A, is no greater than the threshold value, coordination is not required with respect to interference from link A' to link A.
- If the calculated value of  $\Delta T/T$ , expressed as a percentage, is greater than the threshold value, coordination is required.

The comparison of  $\Delta T'/T$ , with the threshold value, expressed as a percentage, shall be carried out in a similar manner.

**3.2 Cases requiring independent treatment of the uplink and the downlink**

- a) In the case of interference into only one link, the uplink or the downlink, the value  $\Delta T_e/T_e$  or  $\Delta T_s/T_s$ , expressed as a percentage, shall be compared with the threshold value of 6%<sup>3</sup>.
- b) In the case of interference into both the uplink and the downlink, between which there is a change of modulation on board the satellite, or in cases where the optional values for transmission gain and equivalent link noise temperature have not been supplied, the values of  $\Delta T_e/T_e$  and  $\Delta T_s/T_s$ , expressed as a percentage, shall each be compared with the threshold value of 6%<sup>3</sup>. (WRC-03)

---

<sup>3</sup> Values other than 6% are used in the application of Appendix 30 and Appendix 30A.

#### 4 Consideration of narrow-band and FM-TV carriers

The method of calculation described in this Appendix may underestimate the interference from slow swept TV carriers into certain narrow-band (single channel per carrier (SCPC)) carriers.

In order to facilitate coordination between the satellite systems and to reduce the number of administrations involved in this procedure, the administrations whose SCPC assignments are either recorded in the Master International Frequency Register or are under coordination may inform an administration notifying its new assignment of the radio frequency channels used in their systems for SCPC transmission, so that the notifying administration may be able to avoid using these channels for FM-TV transmissions.

For this special case, administrations are referred to relevant ITU-R texts for guidance in facilitating subsequent coordination.

Conversely, administrations introducing new systems using SCPC transmissions may seek appropriate information from other administrations on their FM-TV transmissions.

### ANNEX 1

#### Calculation of the topocentric angular separation between two geostationary satellites

The topocentric angular separation  $\theta_t$  between two geostationary satellites from a given earth station can be determined by using the equation:

$$\theta_t = \arccos \left( \frac{d_1^2 + d_2^2 - \left( 84\,332 \sin \frac{\theta_g}{2} \right)^2}{2d_1 \cdot d_2} \right)$$

where  $d_1$  and  $d_2$  are the distances (km), from the earth station to the two satellites respectively, and evaluated as  $d$  by the method described in Annex II, and  $\theta_g$  is as defined in § 2.1.

### ANNEX 2

#### Calculation of the free-space transmission loss

The free-space transmission loss  $L$  can be determined by using the following equation:

$$L = 20 (\log f + \log d) + 32.45 \quad \text{dB}$$

where:

$f$ : frequency (MHz)

$d$ : distance (km).

## AP8-8

- a) The distance  $d$  between an earth station and a geostationary satellite is given by the equation:

$$d = 42\,644 \sqrt{1 - 0.2954 \cos \psi} \quad \text{km}$$

where:

$$\cos \psi = \cos \zeta \times \cos \beta$$

where:

$\zeta$ : latitude of the earth station

$\beta$ : difference in longitude between the satellite and the earth station.

NOTE – If  $\cos \psi < 0.151$ , the satellite is below the horizontal plane.

- b) The distance  $d_s$  between two geostationary satellites is determined as follows:

$$d_s = 84\,332 \sin \frac{\theta_g}{2} \quad \text{km}$$

where:

$\theta_g$ : geocentric angular separation as defined in § 2.1.

## ANNEX 3

### Radiation patterns for earth station antennas to be used when they are not published

When neither measured data nor relevant ITU-R Recommendations accepted by the administrations concerned are available then administrations should use the reference patterns as described below (dBi):

- a) for values of  $\frac{D}{\lambda} \geq 100^4$  (maximum gain  $\geq 48$  dBi approximately):

$$G(\varphi) = G_{max} - 2.5 \times 10^{-3} \left( \frac{D}{\lambda} \varphi \right)^2 \quad \text{for } 0 < \varphi < \varphi_m$$

$$G(\varphi) = G_1 \quad \text{for } \varphi_m \leq \varphi < \varphi_r$$

$$G(\varphi) = 32 - 25 \log \varphi \quad \text{for } \varphi_r \leq \varphi < 48^\circ$$

$$G(\varphi) = -10 \quad \text{for } 48^\circ \leq \varphi < 180^\circ$$

---

<sup>4</sup> In cases where  $\frac{D}{\lambda}$  is not given, it may be estimated from the expression  $20 \log \frac{D}{\lambda} \approx G_{max} - 7.7$ , where  $G_{max}$  is the main lobe antenna gain (dBi).

where:

- $D$ : antenna diameter }  
 $\lambda$ : wavelength } expressed in the same unit  
 $\varphi$ : off-axis angle of the antenna, in degrees, equal to  $\theta_r$  or  $\theta_g$ , as applicable  
 $G_1$ : gain of the first sidelobe =  $2 + 15 \log \frac{D}{\lambda}$

$$\varphi_m = \frac{20 \lambda}{D} \sqrt{G_{max} - G_1} \quad \text{degrees}$$

$$\varphi_r = 15.85 \left( \frac{D}{\lambda} \right)^{-0.6} \quad \text{degrees}$$

b) for values of  $\frac{D}{\lambda} < 100^4$  (maximum gain < 48 dBi approximately):

$$G(\varphi) = G_{max} - 2.5 \times 10^{-3} \left( \frac{D}{\lambda} \varphi \right)^2 \quad \text{for } 0 < \varphi < \varphi_m$$

$$G(\varphi) = G_1 \quad \text{for } \varphi_m \leq \varphi < 100 \frac{\lambda}{D}$$

$$G(\varphi) = 52 - 10 \log \frac{D}{\lambda} - 25 \log \varphi \quad \text{for } 100 \frac{\lambda}{D} \leq \varphi < 48^\circ$$

$$G(\varphi) = 10 - 10 \log \frac{D}{\lambda} \quad \text{for } 48^\circ \leq \varphi \leq 180^\circ$$

The above patterns may be modified as appropriate to achieve a better representation of the actual antenna pattern.

## ANNEX 4

### Example of an application of Appendix 8

#### 1 General

In this example of Case I (see § 2.2.1), two identical satellite networks each with a simple frequency-changing transponder and a global coverage antenna are assumed.

All topocentric angles  $\theta_r$  are assumed to be equal to  $5^\circ$ .

For this angular separation and for an earth station antenna with  $D/\lambda$  greater than 100, the reference radiation pattern ( $32 - 25 \log \theta_r$ ) gives a gain of 14.5 dBi in the direction of the satellite of the other network.

The input data are furnished in § 2 below and are expressed in decibels except for the parameters  $T$  and  $\theta_r$ . In § 3 the calculations are performed in decibels.

It may be noted that since both satellites use global beams there is practically no antenna discrimination between wanted and unwanted signals at the satellite, and that this constitutes a worst case.

## 2 Input data

The values of the network parameters given in the table below are derived from those published in accordance with Appendix 4.

		Symbol*	Value	Unit
Uplink 6 175 MHz	at	$P'_e$	-37	dB(W/Hz)
		$G'_1(\theta_t)$	14.5	dB <i>i</i>
		$G'_2(\delta_{e'})$	15.5	dB <i>i</i>
		$L_u$	200	dB
Downlink 3 950 MHz	at	$P'_s$	-57	dB(W/Hz)
		$G'_3(\eta_e)$	15.5	dB <i>i</i>
		$G_4(\theta_t)$	14.5	dB <i>i</i>
		$L_d$	196	dB
		$10 \log \gamma$	-15	dB
		$T$	105	K
		$\theta_t$	5	degrees

\* All capital symbols, except  $T$ , refer to parameters given in logarithmic units.

## 3 Calculation of $\frac{\Delta T}{T}$

From equation (1)

$$\begin{aligned}
 10 \log \Delta T_s &= P'_e + G'_1(\theta_t) + G'_2(\delta_{e'}) + 228.6 - L_u && \text{dBK} \\
 &= -37 + 14.5 + 15.5 + 228.6 - 200 = 21.6
 \end{aligned}$$

Therefore,

$$\Delta T_s = 145 \quad \text{K}$$

From equation (2)

$$\begin{aligned}
 10 \log \Delta T_e &= P'_s + G'_3(\eta_e) + G_4(\theta_t) + 228.6 - L_d && \text{dBK} \\
 &= -57 + 15.5 + 14.5 + 228.6 - 196 = 5.6
 \end{aligned}$$

Therefore;

$$\Delta T_e = 3.6 \quad \text{K}$$

From equation (3)

$$\begin{aligned}\Delta T &= \gamma \Delta T_s + \Delta T_e \\ &= 0.032 \times 145 + 3.6 = 8.2 \quad \text{K}\end{aligned}$$

Thus

$$\frac{\Delta T}{T} \times 100 = \frac{8.2 \times 100}{105} = 7.8 \quad \%$$

#### 4 Conclusion

In the example shown, the percentage increase in equivalent satellite link noise temperature is 7.8%. Since it exceeds the threshold value of 6%, coordination between the two networks is required.



APPENDIX 9

**Report of an irregularity or infringement**

(See Article 15, Section V)

*Particulars concerning the station infringing the Radio Regulations:*

- 1 Name<sup>1</sup> if known (in BLOCK letters) .....
- 2 Call sign or other identification (in BLOCK letters) .....
- 3 Nationality, if known .....
- 4 Frequency used (kHz, MHz, GHz or THz) .....
- 5 Class of emission<sup>2</sup> .....
- 6 Class of station and nature of service, if known .....
- 7 Location<sup>3, 4, 5</sup> .....

*Particulars concerning the station, the centralizing office or inspection service reporting the irregularity or infringement:*

- 8 Name (in BLOCK letters) .....
- 9 Call sign or other identification (in BLOCK letters) .....
- 10 Nationality .....
- 11 Location<sup>3, 4</sup> .....

*Particulars of the irregularity or infringement:*

- 12 Name<sup>6</sup> of the station (in BLOCK letters) in communication with the station committing the irregularity or infringement .....
- 13 Call sign or other identification (in BLOCK letters) of the station in communication with the station committing the irregularity or infringement .....
- 14 Date and time<sup>7</sup> .....
- 15 Nature of the irregularity or infringement<sup>8</sup> .....
- 16 Extracts from ship log or other information supporting the report .....



**AP9-2**

*Particulars concerning the transmitting station interfered with<sup>9</sup>:*

- 17 Name of the station (in BLOCK letters) .....
- 18 Call sign or other identification (in BLOCK letters) .....
- 19 Frequency assigned (kHz, MHz, GHz or THz) .....
- 20 Frequency measured at the time of the interference .....
- 21 Class of emission<sup>2</sup> and bandwidth (indicate whether measured or estimated, or indicate the necessary bandwidth notified to the Radiocommunication Bureau) .....
- 22 Receiving location<sup>3,4</sup> (in BLOCK letters) where the interference was experienced .....
- 23 Certificate:

I certify that the foregoing report represents, to the best of my knowledge, a complete and accurate account of what took place. ....

Signatures<sup>10</sup> ..... Date: .....

**Instructions for filling in this form**

<sup>1</sup> Each report shall refer to only one station (see Note 6). If it is forwarded as a letter, it shall be in duplicate, and whenever practicable should be typewritten. It may also be forwarded as a telegram.

<sup>2</sup> The class of emission shall contain the basic characteristics listed in Appendix 1. If any characteristic cannot be determined, indicate the unknown symbol with a dash. However, if a station is not able to identify unambiguously whether the modulation is frequency or phase modulation, indicate frequency modulation (F).

<sup>3</sup> In the case of land, fixed, or earth stations, the position shall be expressed in latitude and longitude (Greenwich). If the position cannot be furnished, the area of operation should be indicated.

<sup>4</sup> In the case of ship or aircraft stations, the position shall be expressed either in latitude and longitude (Greenwich) or by a true bearing in degrees and distance in nautical miles, or in kilometres, from some well known place. If the position cannot be furnished, the area of operation should be indicated.

<sup>5</sup> Where space stations are concerned, information shall be furnished on the orbit.

<sup>6</sup> If both communicating stations infringe the Regulations, a separate report shall be made for each of these stations.

<sup>7</sup> The time must be expressed as Coordinated Universal Time (UTC) by a group of four figures (0000 to 2359). If the infringement is prolonged or repeated, the dates and times shall be shown.

<sup>8</sup> A separate report is required for each irregularity or infringement, unless they are repeated within a short time.

<sup>9</sup> This information is to be given only in case of a complaint about interference.

<sup>10</sup> This report shall be signed by the operator who has reported the infringement and countersigned by the Master of the ship or person responsible for the aircraft, or the officer in charge of the station in the case of an infringement reported by a station of the mobile service. When the report originates from a centralizing office or from an inspection service, it shall be signed by the head of that office or service and countersigned by an official of the administration sending it.

**For the use of the administration only**

1 Company controlling the installation of the station against which complaint is made .....

2 Name of the operator of the station held responsible for the irregularity or infringement of the Regulations .....

3 Action taken .....



APPENDIX 10 (REV.WRC-07)

**Report of harmful interference**

(See Article 15, Section VI)

*Particulars concerning the station causing the interference:*

- a* Name, call sign or other means of identification .....
- b* Frequency measured .....
- Date: .....
- Time (UTC): .....
- c* Class of emission<sup>1</sup> .....
- d* Bandwidth (indicate whether measured or estimated) .....
- e* Measured field strength or power flux-density<sup>2</sup> .....
- Date: .....
- Time (UTC): .....
- f* Observed polarization .....
- g* Class of station and nature of service .....
- h* Location/position/area/bearing (QTE<sup>3</sup>) (WRC-07) .....
- i* Location of the facility which made the above measurements .....

*Particulars concerning the transmitting station interfered with:*

- j* Name, call sign or other means of identification .....
- k* Frequency assigned .....
- l* Frequency measured .....
- Date: .....
- Time (UTC): .....
- m* Class of emission<sup>4</sup> .....

---

<sup>1</sup> The class of emission shall contain the basic characteristics listed in Appendix I. If any characteristic cannot be determined, indicate the unknown symbol with a dash. However, if a station is not able to identify unambiguously whether the modulation is frequency or phase modulation, indicate frequency modulation (F).

<sup>2</sup> When measurements are not available, signal strengths according to the QSA scale should be provided.

<sup>3</sup> See the most recent version of Recommendation ITU-R M.1172. (WRC-07)

<sup>4</sup> See footnote 1.

**AP10-2**

- n* Bandwidth (indicate whether measured or estimated, or indicate the necessary bandwidth notified to the Radiocommunication Bureau) .....
- o* Location/position/area .....
- p* Location of the facility which made the above measurements .....

*Particulars furnished by the receiving station experiencing the interference:*

- q* Name of station .....
- r* Location/position/area .....
- s* Dates and times (UTC) of occurrence of harmful interference .....
- t* Bearings (QTE<sup>5</sup>) or other particulars (WRC-07) .....
- u* Nature of interference .....
- v* Field strength or power flux-density of the wanted emission at the receiving station experiencing the interference<sup>6</sup> .....
- Date: .....
- Time (UTC): .....
- w* Polarization of the receiving antenna or observed polarization .....
- x* Action requested .....

NOTE – For convenience and brevity, telegraphic reports shall be in the format above, using the letters in the order listed in lieu of the explanatory titles, but only those letters for which information is provided should be used. However, sufficient information shall be provided to the administration receiving the report, so that an appropriate investigation can be conducted.

---

<sup>5</sup> See footnote 3.

<sup>6</sup> See footnote 2.

## APPENDIX 11 (REV.WRC-19)

**System specifications for double-sideband (DSB), single-sideband (SSB) and digitally modulated emissions in the HF broadcasting service****PART A – Double-sideband (DSB) system****1 System parameters****1.1 Channel spacing**

The nominal spacing for DSB shall be 10 kHz. However, the interleaved channels with a separation of 5 kHz may be used in accordance with the relative protection criteria, provided that the interleaved emission is not to the same geographical area as either of the emissions between which it is interleaved.

**2 Emission characteristics****2.1 Nominal carrier frequencies**

Nominal carrier frequencies shall be integral multiples of 5 kHz.

**2.2 Audio-frequency band**

The upper limit of the audio-frequency band (at -3 dB) of the transmitter shall not exceed 4.5 kHz and the lower limit shall be 150 Hz, with lower frequencies attenuated at a slope of 6 dB per octave.

**2.3 Modulation processing**

If audio-frequency signal processing is used, the dynamic range of the modulating signal shall be not less than 20 dB.

**2.4 Necessary bandwidth**

The necessary bandwidth shall not exceed 9 kHz.

**PART B – Single-sideband (SSB) system****1 System parameters****1.1 Channel spacing**

In a mixed DSB, SSB and digital environment (see Resolution **517 (Rev.WRC-19)**), the channel spacing shall be 10 kHz. In the interest of spectrum conservation, it is also permissible to interleave SSB emissions midway between two adjacent DSB channels, i.e. with 5 kHz separation between carrier frequencies, provided that the interleaved emission is not to the same geographical area as either of the emissions between which it is interleaved.

In an all-inclusive SSB environment, the channel spacing and carrier frequency separation shall be 5 kHz. (WRC-19)

**1.2 Equivalent sideband power**

When the carrier reduction relative to peak envelope power is 6 dB, an equivalent SSB emission is one giving the same audio-frequency signal-to-noise ratio at the receiver output as the corresponding DSB emission, when it is received by a DSB receiver with envelope detection. This is achieved when the sideband power of the SSB emission is 3 dB larger than the total sideband power of the DSB emission. (The peak envelope power of the equivalent SSB emission and the carrier power are the same as that of the DSB emission.)

**2 Emission characteristics****2.1 Nominal carrier frequencies**

Nominal carrier frequencies shall be integral multiples of 5 kHz.

**2.2 Frequency tolerance**

The frequency tolerance shall be 10 Hz.<sup>1</sup>

**2.3 Audio-frequency band**

The upper limit of the audio-frequency band (at –3 dB) of the transmitter shall not exceed 4.5 kHz with a further slope of attenuation of 35 dB/kHz and the lower limit shall be 150 Hz with lower frequencies attenuated at a slope of 6 dB per octave.

**2.4 Modulation processing**

If audio-frequency signal processing is used, the dynamic range of the modulating signal shall be not less than 20 dB.

---

<sup>1</sup> See Note 21 of Appendix 2.

## 2.5 Necessary bandwidth

The necessary bandwidth shall not exceed 4.5 kHz.

## 2.6 Carrier reduction (relative to peak envelope power)

In a mixed DSB, SSB and digital environment, the carrier reduction shall be 6 dB to allow SSB emissions to be received by conventional DSB receivers with envelope detection without significant deterioration of the reception quality. (WRC-03)

## 2.7 Sideband to be emitted

Only the upper sideband shall be used.

## 2.8 Attenuation of the unwanted sideband

The attenuation of the unwanted sideband (lower sideband) and of intermodulation products in that part of the emission spectrum shall be at least 35 dB relative to the wanted sideband signal level. However, since there is in practice a large difference between signal amplitudes in adjacent channels, a greater attenuation is recommended.

# 3 Characteristics of the reference receiver

The reference receiver has the main characteristics as given below. For more detailed characteristics see the relevant ITU-R Recommendations.

## 3.1 Noise limited sensitivity

The value of the noise limited sensitivity is equal to or less than 40 dB( $\mu$ V/m).

## 3.2 Demodulator and carrier acquisition

The reference receiver is equipped with a synchronous demodulator, using for the carrier acquisition a device which regenerates a carrier by means of a suitable control loop which locks the receiver to the incoming carrier. The reference receiver should work as well with DSB emissions as with SSB emissions having a carrier reduced to 6 dB below peak envelope power. (WRC-03)

## 3.3 Overall selectivity

The reference receiver has an overall bandwidth (at  $-3$  dB) of 4 kHz, with a slope of attenuation of 35 dB/kHz.

NOTE – Other combinations of bandwidth and slope of attenuation are possible, as given below, and will provide the same performance at 5 kHz carrier difference.

Slope of attenuation	Overall bandwidth ( $-3$ dB)
25 dB/kHz	3 300 Hz
15 dB/kHz	2 700 Hz



**PART C – Digital system** (WRC-03)**1 System parameters****1.1 Channel spacing**

The initial spacing for digitally modulated emissions shall be 10 kHz. However, interleaved channels with a separation of 5 kHz may be used in accordance with the appropriate protection criteria appearing in Resolution **543 (Rev.WRC-19)**, provided that the interleaved emission is not to the same geographical area as either of the emissions between which it is interleaved. (WRC-19)

**1.2 Channel utilization**

Channels using digitally modulated emissions may share the same spectrum or be interleaved with analogue emissions in the same high frequency broadcasting (HFBC) band, provided the protection afforded to the analogue emissions is at least as great as that which is currently in force for analogue-to-analogue protection. Accomplishing this may require that the digital spectral power density (and total power) be lower by several dB than is currently used for either DSB or SSB emissions.

**2 Emission characteristics****2.1 Bandwidth and centre frequency**

A full digitally modulated emission will have a 10 kHz bandwidth with its centre frequency at any of the 5 kHz centre frequency locations in the channel raster currently in use within the HFBC bands.

Among several possible “simulcast” modes are those having a combination of analogue and digital emissions of the same programme in the same channel, that may use a digital emission of 5 kHz or 10 kHz bandwidth, next to either a 5 kHz or 10 kHz analogue emission. In all cases of this type, the 5 kHz interleaved raster used in HFBC shall be adhered to in placing the emission within these bands.

**2.2 Frequency tolerance**

The frequency tolerance shall be 10 Hz<sup>1</sup>.

---

<sup>1</sup> See Note 21 of Appendix 2.

### 2.3 Audio-frequency band

The quality of service, using digital source coding within a 10 kHz bandwidth, taking into account the need to adapt the emission coding for various levels of error avoidance, detection and correction, can range from the equivalent of monophonic FM (approximately 15 kHz) to the low-level performance of a speech codec (of the order of 3 kHz). The choice of audio quality is connected to the needs of the broadcaster and listener, and includes the consideration of such characteristics as the propagation conditions expected. There is no single specification, only the upper and lower bounds noted in this paragraph.

### 2.4 Modulation

Quadrature amplitude modulation (QAM) with orthogonal frequency division multiplexing (OFDM) shall be used. 64-QAM is feasible under many propagation conditions; others such as 32-, 16- and 8-QAM are specified for use when needed.

### 2.5 RF protection ratio values

The protection ratio values for analogue and digital emissions for co-channel and adjacent channel conditions shall be in accordance with Resolution **543 (Rev.WRC-19)** as provisional RF protection ratio values subject to revision or confirmation by a future competent conference. (WRC-19)



## APPENDIX 12

**Special rules applicable to radiobeacons**

(See Article 28)

**Section I – Aeronautical radiobeacons**

1) The assignment of frequencies to aeronautical radiobeacons operating in the bands between 160 kHz and 535 kHz shall be based on a protection ratio against interference of at least 15 dB for each beacon throughout its service area.

2) The radiated power should be kept to the minimum value necessary to give the desired field strength at the service range.

3) The daylight service range of radiobeacons referred to in § 1) above shall be based on the following field strengths:

4) *Regions 1 and 2*

- 70  $\mu\text{V/m}$  for radiobeacons north of 30° N;
- 120  $\mu\text{V/m}$  for radiobeacons between 30° N and 30° S;
- 70  $\mu\text{V/m}$  for radiobeacons south of 30° S.

5) *Region 3*

- 70  $\mu\text{V/m}$  for radiobeacons north of 40° N;
- 120  $\mu\text{V/m}$  for radiobeacons between 40° N and 50° S;
- 70  $\mu\text{V/m}$  for radiobeacons south of 50° S.

**Section II – Maritime Radiobeacons**

1) The protection ratio required for assignment of frequencies to maritime radiobeacons operating in the bands between 283.5 kHz and 335 kHz shall be based on the effective radiated power being kept to the minimum value necessary to give the desired field strength at the service range and the need to provide adequate geographical separation between radiobeacons operating on the same frequency and at the same time, to avoid harmful interference.

2) The daylight service range of the radiobeacons referred to in § 1) above shall be based on the following field strengths:

3) *Region 1*

- 50  $\mu\text{V/m}$  for radiobeacons north of 43° N;
- 75  $\mu\text{V/m}$  for radiobeacons between 43° N and 30° N;
- 100  $\mu\text{V/m}$  for radiobeacons between 30° N and 30° S;
- 75  $\mu\text{V/m}$  for radiobeacons between 30° S and 43° S;
- 50  $\mu\text{V/m}$  for radiobeacons south of 43° S.

## AP12-2

### 4) *Region 2*

- 50  $\mu\text{V/m}$  for radiobeacons north of  $40^\circ\text{ N}$ ;
- 75  $\mu\text{V/m}$  for radiobeacons between  $40^\circ\text{ N}$  and  $31^\circ\text{ N}$ ;
- 100  $\mu\text{V/m}$  for radiobeacons between  $31^\circ\text{ N}$  and  $30^\circ\text{ S}$ ;
- 75  $\mu\text{V/m}$  for radiobeacons between  $30^\circ\text{ S}$  and  $43^\circ\text{ S}$ ;
- 50  $\mu\text{V/m}$  for radiobeacons south of  $43^\circ\text{ S}$ .

### 5) *Region 3*

- 75  $\mu\text{V/m}$  for radiobeacons north of  $40^\circ\text{ N}$ ;
- 100  $\mu\text{V/m}$  for radiobeacons between  $40^\circ\text{ N}$  and  $50^\circ\text{ S}$ ;
- 75  $\mu\text{V/m}$  for radiobeacons south of  $50^\circ\text{ S}$ .

6) The carrier frequencies of maritime radiobeacons and the separation between channels shall be based on the use of integer multiples of 100 Hz. The separation between adjacent carrier frequencies should be based on relevant ITU-R Recommendations.

## APPENDIX 14 (REV.WRC-07)

**Phonetic alphabet and figure code**

(See Articles 30 and 57) (WRC-07)

1 When it is necessary to spell out call signs, service abbreviations and words, the following letter spelling table shall be used:

<i>Letter to be transmitted</i>	<i>Code word to be used</i>	<i>Spoken as<sup>1</sup></i>
A	Alfa	<u>AL</u> FAH
B	Bravo	<u>BRAH</u> VOH
C	Charlie	<u>CHAR</u> LEE or <u>SHAR</u> LEE
D	Delta	<u>DELL</u> TAH
E	Echo	<u>ECK</u> OH
F	Foxtrot	<u>FOKS</u> TROT
G	Golf	GOLF
H	Hotel	HOH <u>TELL</u>
I	India	<u>IN</u> DEE AH
J	Juliett	<u>JEW</u> LEE ETT
K	Kilo	<u>KEY</u> LOH
L	Lima	<u>LEE</u> MAH
M	Mike	MIKE
N	November	NO <u>VEM</u> BER
O	Oscar	<u>OSS</u> CAH
P	Papa	PAH <u>PAH</u>
Q	Quebec	KEH <u>BECK</u>
R	Romeo	<u>ROW</u> ME OH
S	Sierra	SEE <u>AIR</u> RAH
T	Tango	<u>TANG</u> GO
U	Uniform	<u>YOU</u> NEE FORM or <u>OO</u> NEE FORM
V	Victor	<u>VIK</u> TAH
W	Whiskey	<u>WISS</u> KEY
X	X-ray	<u>ECKS</u> RAY
Y	Yankee	<u>YANG</u> KEY
Z	Zulu	<u>ZOO</u> LOO

---

<sup>1</sup> The syllables to be emphasized are underlined.

**AP14-2**

2 When it is necessary to spell out figures or marks, the following table shall be used:

<i>Figure or mark to be transmitted</i>	<i>Code word to be used</i>	<i>Spoken as<sup>2</sup></i>
0	Nadazero	NAH-DAH-ZAY-ROH
1	Unaone	OO-NAH-WUN
2	Bissotwo	BEES-SOH-TOO
3	Terrathree	TAY-RAH-TREE
4	Kartefour	KAR-TAY-FOWER
5	Pantafive	PAN-TAH-FIVE
6	Soxisix	SOK-SEE-SIX
7	Setteseven	SAY-TAY-SEVEN
8	Oktoeight	OK-TOH-AIT
9	Novenine	NO-VAY-NINER
Decimal point	Decimal	DAY-SEE-MAL
Full stop	Stop	STOP

3 However, stations of the same country, when communicating between themselves, may use any other table recognized by their administration.

---

<sup>2</sup> Each syllable should be equally emphasized.

## APPENDIX 15 (REV.WRC-19)

## Frequencies for distress and safety communications for the Global Maritime Distress and Safety System

(See Article 31)

The frequencies for distress and safety communications for the GMDSS are given in Tables 15-1 and 15-2 for frequencies below and above 30 MHz, respectively.

TABLE 15-1 (WRC-07)

### Frequencies below 30 MHz

Frequency (kHz)	Description of usage	Notes
490	MSI	The frequency 490 kHz is used exclusively for maritime safety information (MSI). (WRC-03)
518	MSI	The frequency 518 kHz is used exclusively by the international NAVTEX system.
*2 174.5	NBDP-COM	
*2 182	RTP-COM	The frequency 2 182 kHz uses class of emission J3E. See also No. <b>52.190</b> .
*2 187.5	DSC	
3 023	AERO-SAR	The aeronautical carrier (reference) frequencies 3 023 kHz and 5 680 kHz may be used for intercommunication between mobile stations engaged in coordinated search and rescue operations, and for communication between these stations and participating land stations, in accordance with the provisions of Appendix 27 (see Nos. <b>5.111</b> and <b>5.115</b> ).
*4 125	RTP-COM	See also No. <b>52.221</b> . The carrier frequency 4 125 kHz may be used by aircraft stations to communicate with stations of the maritime mobile service for distress and safety purposes, including search and rescue (see No. <b>30.11</b> ).
*4 177.5	NBDP-COM	
*4 207.5	DSC	
4 209.5	MSI	The frequency 4 209.5 kHz is exclusively used for NAVTEX-type transmissions (see Resolution <b>339 (Rev.WRC-07)</b> ).
4 210	MSI-HF	
5 680	AERO-SAR	See note under 3 023 kHz above.
*6 215	RTP-COM	See also No. <b>52.221</b> .
*6 268	NBDP-COM	
*6 312	DSC	



TABLE 15-1 (end) (WRC-07)

Frequency (kHz)	Description of usage	Notes
6 314	MSI-HF	
*8 291	RTP-COM	
*8 376.5	NBDP-COM	
*8 414.5	DSC	
8 416.5	MSI-HF	
*12 290	RTP-COM	
*12 520	NBDP-COM	
*12 577	DSC	
12 579	MSI-HF	
*16 420	RTP-COM	
*16 695	NBDP-COM	
*16 804.5	DSC	
16 806.5	MSI-HF	
19 680.5	MSI-HF	
22 376	MSI-HF	
26 100.5	MSI-HF	

**Legend:**

**AERO-SAR** These aeronautical carrier (reference) frequencies may be used for distress and safety purposes by mobile stations engaged in coordinated search and rescue operations.

**DSC** These frequencies are used exclusively for distress and safety calls using digital selective calling in accordance with No. 32.5 (see Nos. 33.8 and 33.32). (WRC-07)

**MSI** In the maritime mobile service, these frequencies are used exclusively for the transmission of maritime safety information (MSI) (including meteorological and navigational warnings and urgent information) by coast stations to ships, by means of narrow-band direct-printing telegraphy.

**MSI-HF** In the maritime mobile service, these frequencies are used exclusively for the transmission of high seas MSI by coast stations to ships, by means of narrow-band direct-printing telegraphy.

**NBDP-COM** These frequencies are used exclusively for distress and safety communications (traffic) using narrow-band direct-printing telegraphy.

**RTP-COM** These carrier frequencies are used for distress and safety communications (traffic) by radiotelephony.

\* Except as provided in these Regulations, any emission capable of causing harmful interference to distress, alarm, urgency or safety communications on the frequencies denoted by an asterisk (\*) is prohibited. Any emission causing harmful interference to distress and safety communications on any of the discrete frequencies identified in this Appendix is prohibited. (WRC-07)

TABLE 15-2 (WRC-19)

## Frequencies above 30 MHz (VHF/UHF)

Frequency (MHz)	Description of usage	Notes
*121.5	AERO-SAR	<p>The aeronautical emergency frequency 121.5 MHz is used for the purposes of distress and urgency for radiotelephony by stations of the aeronautical mobile service using frequencies in the frequency band between 117.975 MHz and 137 MHz. This frequency may also be used for these purposes by survival craft stations. Use of the frequency 121.5 MHz by emergency position-indicating radio beacons shall be in accordance with Recommendation ITU-R M.690-3.</p> <p>Mobile stations of the maritime mobile service may communicate with stations of the aeronautical mobile service on the aeronautical emergency frequency 121.5 MHz for the purposes of distress and urgency only, and on the aeronautical auxiliary frequency 123.1 MHz for coordinated search and rescue operations, using class A3E emissions for both frequencies (see also Nos. <b>5.111</b> and <b>5.200</b>). They shall then comply with any special arrangement between governments concerned by which the aeronautical mobile service is regulated.</p>
123.1	AERO-SAR	<p>The aeronautical auxiliary frequency 123.1 MHz, which is auxiliary to the aeronautical emergency frequency 121.5 MHz, is for use by stations of the aeronautical mobile service and by other mobile and land stations engaged in coordinated search and rescue operations (see also No. <b>5.200</b>).</p> <p>Mobile stations of the maritime mobile service may communicate with stations of the aeronautical mobile service on the aeronautical emergency frequency 121.5 MHz for the purposes of distress and urgency only, and on the aeronautical auxiliary frequency 123.1 MHz for coordinated search and rescue operations, using class A3E emissions for both frequencies (see also Nos. <b>5.111</b> and <b>5.200</b>). They shall then comply with any special arrangement between governments concerned by which the aeronautical mobile service is regulated.</p>
156.3	VHF-CH06	The frequency 156.3 MHz may be used for communication between ship stations and aircraft stations engaged in coordinated search and rescue operations. It may also be used by aircraft stations to communicate with ship stations for other safety purposes (see also Note <i>f</i> ) in Appendix <b>18</b> ).
*156.525	VHF-CH70	The frequency 156.525 MHz is used in the maritime mobile service for distress and safety calls using digital selective calling (see also Nos. <b>4.9</b> , <b>5.227</b> , <b>30.2</b> and <b>30.3</b> ).
156.650	VHF-CH13	The frequency 156.650 MHz is used for ship-to-ship communications relating to the safety of navigation in accordance with Note <i>k</i> ) in Appendix <b>18</b> .
*156.8	VHF-CH16	The frequency 156.8 MHz is used for distress and safety communications by radiotelephony. Additionally, the frequency 156.8 MHz may be used by aircraft stations for safety purposes only.
*161.975	AIS-SART VHF CH AIS 1	AIS 1 is used for AIS search and rescue transmitters (AIS-SART) for use in search and rescue operations.
*162.025	AIS-SART VHF CH AIS 2	AIS 2 is used for AIS search and rescue transmitters (AIS-SART) for use in search and rescue operations.

TABLE 15-2 (end) (WRC-19)

Frequency (MHz)	Description of usage	Notes
*406-406.1	406-EPIRB	This frequency band is used exclusively by satellite emergency position-indicating radio beacons in the Earth-to-space direction (see No. <b>5.266</b> ).
1 530-1 544	SAT-COM	In addition to its availability for routine non-safety purposes, the band 1 530-1 544 MHz is used for distress and safety purposes in the space-to-Earth direction in the maritime mobile-satellite service. GMDSS distress, urgency and safety communications have priority in this band (see No. <b>5.353A</b> ).
*1 544-1 545	D&S-OPS	Use of the band 1 544-1 545 MHz (space-to-Earth) is limited to distress and safety operations (see No. <b>5.356</b> ), including feeder links of satellites needed to relay the emissions of satellite emergency position-indicating radio beacons to earth stations and narrow-band (space-to-Earth) links from space stations to mobile stations.
1 621.35-1 626.5	SAT-COM	In addition to its availability for routine non-safety purposes, the frequency band 1 621.35-1 626.5 MHz is used for distress and safety purposes in the Earth-to-space and space-to-Earth directions in the maritime mobile-satellite service. GMDSS distress, urgency and safety communications have priority in this band over non-safety communications within the same satellite system. (WRC-19)
1 626.5-1 645.5	SAT-COM	In addition to its availability for routine non-safety purposes, the band 1 626.5-1 645.5 MHz is used for distress and safety purposes in the Earth-to-space direction in the maritime mobile-satellite service. GMDSS distress, urgency and safety communications have priority in this band (see No. <b>5.353A</b> ).
*1 645.5-1 646.5	D&S-OPS	Use of the band 1 645.5-1 646.5 MHz (Earth-to-space) is limited to distress and safety operations (see No. <b>5.375</b> ).
9 200-9 500	SARTS	This frequency band is used by radar transponders to facilitate search and rescue.

**Legend:**

**AERO-SAR** These aeronautical carrier (reference) frequencies may be used for distress and safety purposes by mobile stations engaged in coordinated search and rescue operations.

**D&S-OPS** The use of these bands is limited to distress and safety operations of satellite emergency position-indicating radio beacons (EPIRBs).

**SAT-COM** These frequency bands are available for distress and safety purposes in the maritime mobile-satellite service (see Notes).

**VHF-CH#** These VHF frequencies are used for distress and safety purposes. The channel number (CH#) refers to the VHF channel as listed in Appendix 18, which should also be consulted.

**AIS** These frequencies are used by automatic identification systems (AIS), which should operate in accordance with the most recent version of Recommendation ITU-R M.1371. (WRC-07)

\* Except as provided in these Regulations, any emission capable of causing harmful interference to distress, alarm, urgency or safety communications on the frequencies denoted by an asterisk (\*) is prohibited. Any emission causing harmful interference to distress and safety communications on any of the discrete frequencies identified in this Appendix is prohibited. (WRC-07)

## APPENDIX 16 (REV.WRC-07)

**Documents with which stations on board ships  
and aircraft shall be provided**

(See Articles 42 and 51)

**Section I – Ship stations for which a Global Maritime Distress and Safety System  
installation is required by international agreement**

These stations shall be provided with:

- 1 the licence prescribed by Article 18;
- 2 certificates of the operator or operators;
- 3 a log in which the following are recorded as they occur, together with the time of the occurrence, unless administrations have adopted other arrangements for recording all information which the log should contain:
  - a) a summary of communications relating to distress, urgency and safety traffic;
  - b) a reference to important service incidents;
- 4 the List of Ship Stations and Maritime Mobile Service Identity Assignments (see Article 20) in either printed or electronic format; (WRC-07)
- 5 the List of Coast Stations and Special Service Stations (see Article 20) in either printed or electronic format; (WRC-07)
- 6 the Manual for Use by the Maritime Mobile and Maritime Mobile-Satellite Services (see Article 20) in either printed or electronic format. (WRC-07)

NOTE – An administration may exempt a ship from the carriage of the documents mentioned in items 5 and 6 above under various circumstances (for example, when that ship carries equivalent information for the ship's specified trading area).

**Section II – Other ship stations for which a radio installation is required by  
regional or international agreement** (WRC-07)

These stations shall be provided with:

- 1 the licence prescribed by Article 18;
- 2 certificates of the operator or operators;
- 3 a log or other arrangements which the administration may have adopted for that purpose, in which a summary of communications related to distress, urgency and safety traffic shall be recorded together with the time of their occurrence;
- 4 the List of Coast Stations and Special Service Stations (see Article 20) in either printed or electronic format;

## **AP16-2**

5 the relevant rules and procedures of radiocommunications, e.g. Manual for Use by the Maritime Mobile and Maritime Mobile-Satellite Services (paper or electronic format) (see Article 20).

NOTE – An administration may exempt a ship from the carriage of the documents mentioned in items 4 and 5 above under various circumstances (for example, when that ship carries equivalent information for the ship's specified trading area).

### **Section III – Other ship stations** (WRC-07)

These stations shall be provided with:

- 1 the documents mentioned in items 1 and 2 of Section II;
- 2 the documents mentioned in items 4 and 5 of Section II, in accordance with the requirements of the administrations concerned.

NOTE – An administration may exempt a ship from the carriage of the documents mentioned in item 2 above under various circumstances (for example, when that ship carries equivalent information for the ship's specified trading area). Administrations may also, by mutual agreement, exempt ships travelling only between their national jurisdictions from the licensing prescribed by Article 18 and the carriage of the documents mentioned in item 1 above, provided those vessels are otherwise licensed or authorized by regulation.

### **Section IV – Stations on board aircraft** (WRC-07)

These stations shall be provided with:

- 1 the documents mentioned in items 1 and 2 of Section I;
- 2 a log, unless administrations have adopted other arrangements for recording all information which the log should contain;
- 3 those published documents, in either printed or electronic formats, containing official information relating to stations which the aircraft station may use for the execution of its service.

## APPENDIX 17 (REV.WRC-19)

## Frequencies and channelling arrangements in the high-frequency bands for the maritime mobile service

(See Article 52)

### PART A – Table of subdivided bands (WRC-19)

In the Table, where appropriate<sup>1</sup>, the assignable frequencies in a given band for each usage are:

- indicated by the lowest and highest frequency, in heavy type, assigned in that band;
- regularly spaced, the number of assignable frequencies (*f*) and the spacing in kHz being indicated in italics.

**Table of frequencies (kHz) to be used in the band between 4 000 kHz and 27 500 kHz allocated exclusively to the maritime mobile service**

Band (MHz)	4	6	8	12	16	18/19	22	25/26
Limits (kHz)	4 063	6 200	8 195	12 230	16 360	18 780	22 000	25 070
Frequencies assignable to ship stations for oceanographic data transmission <i>c)</i>	<b>4 063.3</b> to <b>4 064.8</b>  <i>6 f.</i> <i>0.3 kHz</i>							
Limits (kHz)	4 065	6 200	8 195	12 230	16 360	18 780	22 000	25 070
Frequencies assignable to ship stations for telephony, duplex operation <i>a) i) t)</i>	<b>4 066.4</b> to <b>4 144.4</b>  <i>27 f.</i> <i>3 kHz</i>	<b>6 201.4</b> to <b>6 222.4</b>  <i>8 f.</i> <i>3 kHz</i>	<b>8 196.4</b> to <b>8 292.4</b>  <i>33 f.</i> <i>3 kHz</i>	<b>12 231.4</b> to <b>12 351.4</b>  <i>41 f.</i> <i>3 kHz</i>	<b>16 361.4</b> to <b>16 526.4</b>  <i>56 f.</i> <i>3 kHz</i>	<b>18 781.4</b> to <b>18 823.4</b>  <i>15 f.</i> <i>3 kHz</i>	<b>22 001.4</b> to <b>22 157.4</b>  <i>53 f.</i> <i>3 kHz</i>	<b>25 071.4</b> to <b>25 098.4</b>  <i>10 f.</i> <i>3 kHz</i>
Limits (kHz)	4 146	6 224	8 294	12 353	16 528	18 825	22 159	25 100

<sup>1</sup> Within the non-shaded boxes.

**Table of frequencies (kHz) to be used in the band between 4 000 kHz and 27 500 kHz allocated exclusively to the maritime mobile service (continued)**

<b>Band (MHz)</b>	<b>4</b>	<b>6</b>	<b>8</b>	<b>12</b>	<b>16</b>	<b>18/19</b>	<b>22</b>	<b>25/26</b>
Limits (kHz)	4 146	6 224	8 294	12 353	16 528	18 825	22 159	25 100
Frequencies assignable to ship stations as well as coast stations for telephony, simplex operation <i>a) u) v)</i>	<b>4 147.4</b> to <b>4 150.4</b>  <i>2 f.</i> <i>3 kHz</i>	<b>6 225.4</b> to <b>6 231.4</b>  <i>3 f.</i> <i>3 kHz</i>	<b>8 295.4</b> to <b>8 298.4</b>  <i>2 f.</i> <i>3 kHz</i>	<b>12 354.4</b> to <b>12 366.4</b>  <i>5 f.</i> <i>3 kHz</i>	<b>16 529.4</b> to <b>16 547.4</b>  <i>7 f.</i> <i>3 kHz</i>	<b>18 826.4</b> to <b>18 844.4</b>  <i>7 f.</i> <i>3 kHz</i>	<b>22 160.4</b> to <b>22 178.4</b>  <i>7 f.</i> <i>3 kHz</i>	<b>25 101.4</b> to <b>25 119.4</b>  <i>7 f.</i> <i>3 kHz</i>
Limits (kHz)	4 152	6 233	8 300	12 368	16 549	18 846	22 180	25 121
Frequencies assignable to ship stations for data transmission <i>e) m) p) q) r) u)</i>	<b>4 153.5</b> to <b>4 168.5</b>  <i>6 f.</i> <i>3 kHz</i>	<b>6 234.5</b> to <b>6 258.5</b>  <i>9 f.</i> <i>3 kHz</i>	<b>8 301.5</b> to <b>8 337.5</b>  <i>13 f.</i> <i>3 kHz</i>	<b>12 369.5</b> to <b>12 417.5</b>  <i>17 f.</i> <i>3 kHz</i>	<b>16 550.5</b> to <b>16 613.5</b>  <i>22 f.</i> <i>3 kHz</i>	<b>18 847.5</b> to <b>18 871.5</b>  <i>9 f.</i> <i>3 kHz</i>	<b>22 181.5</b> to <b>22 238.5</b>  <i>20 f.</i> <i>3 kHz</i>	<b>25 122.5</b> to <b>25 176.5</b>  <i>19 f.</i> <i>3 kHz</i>
Limits (kHz)	4 170	6 260	8 339	12 419	16 615	18 873	22 240	25 178
Frequencies assignable to ship as well as coast stations for data transmission <i>e) m) p) q) u)</i>								<b>25 179.5</b> to <b>25 206.5</b>  <i>10 f.</i> <i>3 kHz</i>
Limits (kHz)	4 170	6 260	8 339	12 419	16 615	18 873	22 240	25 208.25
Frequencies (paired and non-paired) assignable to ship stations for narrow-band direct-printing (NBDP) telegraphy and data transmission systems at speeds not exceeding 100 Bd for FSK and 200 Bd for PSK <i>b) d)</i>		<b>6 260.25</b> to <b>6 260.75</b>  <i>2 f.</i> <i>0.5 kHz</i>	<b>8 339.25</b> to <b>8 339.75</b>  <i>2 f.</i> <i>0.5 kHz</i>	<b>12 419.25</b> to <b>12 419.75</b>  <i>2 f.</i> <i>0.5 kHz</i>	<b>16 615.25</b> to <b>16 616.75</b>  <i>4 f.</i> <i>0.5 kHz</i>	<b>18 873.5</b> to <b>18 880</b>  <i>14 f.</i> <i>0.5 kHz</i>		
Limits (kHz)	4 170	6 261	8 340	12 420	16 617	18 880.25	22 240	25 208.25
Frequencies assignable to ship stations for oceanographic data transmission <i>c)</i>		<b>6 261.3</b> to <b>6 262.5</b>  <i>5 f.</i> <i>0.3 kHz</i>	<b>8 340.3</b> to <b>8 341.5</b>  <i>5 f.</i> <i>0.3 kHz</i>	<b>12 420.3</b> to <b>12 421.5</b>  <i>5 f.</i> <i>0.3 kHz</i>	<b>16 617.3</b> to <b>16 618.5</b>  <i>5 f.</i> <i>0.3 kHz</i>		<b>22 240.3</b> to <b>22 241.5</b>  <i>5 f.</i> <i>0.3 kHz</i>	
Limits (kHz)	4 170	6 262.75	8 341.75	12 421.75	16 618.75	18 880.25	22 241.75	25 208.25

**Table of frequencies (kHz) to be used in the band between 4 000 kHz and 27 500 kHz  
allocated exclusively to the maritime mobile service (continued)**

<b>Band (MHz)</b>	<b>4</b>	<b>6</b>	<b>8</b>	<b>12</b>	<b>16</b>	<b>18/19</b>	<b>22</b>	<b>25/26</b>
Limits (kHz)	4 170	6 262.75	8 341.75	12 421.75	16 618.75	18 880.25	22 241.75	25 208.25
Frequencies (paired and non-paired) assignable to ship stations for narrow-band direct-printing (NBDP) telegraphy and data transmission systems at speeds not exceeding 100 Bd for FSK and 200 Bd for PSK <i>b) d) j)</i>	<b>4 170.5</b> to <b>4 180</b>  <i>20 f.</i> <i>0.5 kHz</i>	<b>6 263</b> to <b>6 269.5</b>  <i>14 f.</i> <i>0.5 kHz</i>		<b>12 422</b>  <i>1 f.</i> <i>0.5 kHz</i>				
Limits (kHz)	4 180.25	6 269.75	8 341.75	12 422.25	16 618.75	18 880.25	22 241.75	25 208.25
Frequencies assignable to ship stations for data transmission <i>e) m) p) q) u)</i>	<b>4 181.75</b> to <b>4 187.75</b>  <i>3 f.</i> <i>3 kHz</i>	<b>6 271.25</b> to <b>6 277.25</b>  <i>3 f.</i> <i>3 kHz</i>	<b>8 343.25</b> to <b>8 358.25</b>  <i>6 f.</i> <i>3 kHz</i>	<b>12 423.75</b> to <b>12 450.75</b>  <i>10 f.</i> <i>3 kHz</i>	<b>16 620.25</b> to <b>16 680.25</b>  <i>21 f.</i> <i>3 kHz</i>	<b>18 881.75</b> to <b>18 893.75</b>  <i>5 f.</i> <i>3 kHz</i>	<b>22 243.25</b> to <b>22 288.25</b>  <i>16 f.</i> <i>3 kHz</i>	
Limits (kHz)	4 189.25	6 278.75	8 359.75	12 452.25	16 681.75	18 895.25	22 289.75	25 208.25
Frequencies assignable to ship as well as coast stations for data transmission <i>e) m) p) q) u)</i>	<b>4 190.75</b> to <b>4 196.75</b>  <i>3 f.</i> <i>3 kHz</i>	<b>6 280.25</b> to <b>6 310.25</b>  <i>11 f.</i> <i>3 kHz</i>	<b>8 361.25</b> to <b>8 373.25</b>  <i>5 f.</i> <i>3 kHz</i>	<b>12 453.75</b> to <b>12 474.75</b>  <i>8 f.</i> <i>3 kHz</i>		<b>18 896.75</b>  <i>1 f.</i> <i>3 kHz</i>		
Limits (kHz)	4 198.25	6 311.75	8 374.75	12 476.25	16 681.75	18 898.25	22 289.75	25 208.25
Frequencies assignable to coast stations for data transmission <i>e) m) p) q) u)</i>	<b>4 199.75</b> to <b>4 205.75</b>  <i>3 f.</i> <i>3 kHz</i>							
Limits (kHz)	4 207.25	6 311.75	8 374.75	12 476.25	16 681.75	18 898.25	22 289.75	25 208.25
Frequencies (paired and non-paired) assignable to ship stations for NBDP telegraphy and data transmission systems at speeds not exceeding 100 bauds for FSK and 200 bauds for PSK <i>b) d) j)</i>			<b>8 375</b> to <b>8 383.5</b>  <i>18 f.</i> <i>0.5 kHz</i>	<b>12 476.5</b> to <b>12 522.5</b>  <i>93 f.</i> <i>0.5 kHz</i>	<b>16 682</b> to <b>16 698.5</b>  <i>34 f.</i> <i>0.5 kHz</i>		<b>22 290</b> to <b>22 299</b>  <i>19 f.</i> <i>0.5 kHz</i>	
Limits (kHz)	4 207.25	6 311.75	8 383.75	12 522.75	16 698.75	18 898.25	22 299.25	25 208.25



**Table of frequencies (kHz) to be used in the band between 4 000 kHz and 27 500 kHz allocated exclusively to the maritime mobile service (continued)**

<b>Band (MHz)</b>	<b>4</b>	<b>6</b>	<b>8</b>	<b>12</b>	<b>16</b>	<b>18/19</b>	<b>22</b>	<b>25/26</b>
Limits (kHz)	4 207.25	6 311.75	8 383.75	12 522.75	16 698.75	18 898.25	22 299.25	25 208.25
Frequencies assignable to ship as well as coast stations for data transmission <i>e) p) q) u)</i>			<b>8 385.5</b> to <b>8 406.5</b>  <i>8 f.</i> <i>3 kHz</i>	<b>12 524.25</b> to <b>12 575.25</b>  <i>18 f.</i> <i>3 kHz</i>	<b>16 700.5</b> to <b>16 802.5</b>  <i>35 f.</i> <i>3 kHz</i>		<b>22 300.75</b> to <b>22 372.75</b>  <i>25 f.</i> <i>3 kHz</i>	
Limits (kHz)	4 207.25	6 311.75	8 408	12 576.75	16 804	18 898.25	22 374.25	25 208.25
Frequencies assignable to coast stations for data transmission <i>e) m) p) q) u)</i>			<b>8 409.5</b> to <b>8 412.5</b>  <i>2 f.</i> <i>3 kHz</i>					
Limits (kHz)	4 207.25	6 311.75	8 414	12 576.75	16 804	18 898.25	22 374.25	25 208.25
Frequencies assignable to ship stations for digital selective calling <i>k) l)</i>	<b>4 207.5</b> to <b>4 209</b>  <i>4 f.</i> <i>0.5 kHz</i>	<b>6 312</b> to <b>6 313.5</b>  <i>4 f.</i> <i>0.5 kHz</i>	<b>8 414.5</b> to <b>8 416</b>  <i>4 f.</i> <i>0.5 kHz</i>	<b>12 577</b> to <b>12 578.5</b>  <i>4 f.</i> <i>0.5 kHz</i>	<b>16 804.5</b> to <b>16 806</b>  <i>4 f.</i> <i>0.5 kHz</i>	<b>18 898.5</b> to <b>18 899.5</b>  <i>3 f.</i> <i>0.5 kHz</i>	<b>22 374.5</b> to <b>22 375.5</b>  <i>3 f.</i> <i>0.5 kHz</i>	<b>25 208.5</b> to <b>25 209.5</b>  <i>3 f.</i> <i>0.5 kHz</i>
Limits (kHz)	4 209.25	6 313.75	8 416.25	12 578.75	16 806.25	18 899.75	22 375.75	25 210
Limits (kHz)	4 209.25	6 313.75	8 416.25	12 578.75	16 806.25	19 680.25	22 375.75	26 100.25
Frequencies (paired and non-paired) assignable to coast stations for NBDP and data transmission systems, at speeds not exceeding 100 Bd for FSK and 200 Bd for PSK <i>b) d) n) o)</i>	<b>4 209.5</b> to <b>4 216</b>  <i>14 f.</i> <i>0.5 kHz</i>	<b>6 314</b> to <b>6 321.5</b>  <i>16 f.</i> <i>0.5 kHz</i>	<b>8 416.5</b> to <b>8 423.5</b>  <i>15 f.</i> <i>0.5 kHz</i>	<b>12 579</b> to <b>12 624.5</b>  <i>92 f.</i> <i>0.5 kHz</i>	<b>16 806.5</b> to <b>16 821.5</b>  <i>31 f.</i> <i>0.5 kHz</i>	<b>19 680.5</b>   <i>1 f.</i> <i>0.5 kHz</i>	<b>22 376</b>   <i>1 f.</i> <i>0.5 kHz</i>	<b>26 100.5</b> to <b>26 102.5</b>  <i>5 f.</i> <i>0.5 kHz</i>
Limits (kHz)	4 216.25	6 321.75	8 423.75	12 624.75	16 821.75	19 680.75	22 376.25	26 102.75
Frequencies assignable to ship stations for data transmission <i>e) m) p) q) u)</i>							<b>22 377.75</b> to <b>22 380.75</b>  <i>2 f.</i> <i>3 kHz</i>	
Limits (kHz)	4 216.25	6 321.75	8 423.75	12 624.75	16 821.75	19 680.75	22 382.25	26 102.75
Frequencies assignable to ship as well as coast stations for data transmission <i>e) m) p) q) u)</i>	<b>4 217.75</b>   <i>1 f.</i> <i>3 kHz</i>				<b>16 823.25</b> to <b>16 838.25</b>  <i>6 f.</i> <i>3 kHz</i>			
Limits (kHz)	4 219.25	6 321.75	8 423.75	12 624.75	16 839.75	19 680.75	22 382.25	26 102.75

**Table of frequencies (kHz) to be used in the band between 4 000 kHz and 27 500 kHz allocated exclusively to the maritime mobile service (continued)**

<b>Band (MHz)</b>	<b>4</b>	<b>6</b>	<b>8</b>	<b>12</b>	<b>16</b>	<b>18/19</b>	<b>22</b>	<b>25/26</b>
Limits (kHz)	4 219.25	6 321.75	8 423.75	12 624.75	16 839.75	19 680.75	22 382.25	26 102.75
Frequencies assignable to coast stations for data transmission <i>e) m) q) u)</i>		<b>6 323.25</b> to <b>6 329.25</b>  <i>3 f.</i> <i>3 kHz</i>	<b>8 425.5</b> to <b>8 434.5</b>  <i>4 f.</i> <i>3 kHz</i>	<b>12 626.25</b> to <b>12 653.25</b>  <i>10 f.</i> <i>3 kHz</i>	<b>16 841.25</b> to <b>16 901.25</b>  <i>21 f.</i> <i>3 kHz</i>	<b>19 682.25</b>   <i>1 f.</i> <i>3 kHz</i>		<b>26 104.25</b> to <b>26 119.25</b>  <i>6 f.</i> <i>3 kHz</i>
Limits (kHz)	4 219.25	6 330.75	8 436.25	12 654.75	16 902.75	19 683.75	22 382.25	26 120.75
Frequencies (paired and non-paired) assignable to coast stations for NBDP and data transmission systems, at speeds not exceeding 100 Bd for FSK and 200 Bd for PSK <i>b) d)</i>				<b>12 655</b> to <b>12 656.5</b>  <i>4 f.</i> <i>0.5 kHz</i>		<b>19 684</b> to <b>19 691</b>  <i>15 f.</i> <i>0.5 kHz</i>	<b>22 382.5</b> to <b>22 389</b>  <i>14 f.</i> <i>0.5 kHz</i>	
Limits (kHz)	4 219.25	6 330.75	8 436.25	12 656.75	16 902.75	19 691.25	22 389.25	26 120.75
Frequencies assignable to coast stations for data transmission <i>e) m) p) q) u)</i>						<b>19 692.75</b> to <b>19 701.75</b>  <i>4 f.</i> <i>3 kHz</i>	<b>22 390.75</b> to <b>22 441.75</b>  <i>18 f.</i> <i>3 kHz</i>	
Limits (kHz)	4 219.25	6 330.75	8 436.25	12 656.75	16 902.75	19 703.25	22 443.25	26 120.75
Frequencies (non-paired) assignable to coast stations for NBDP and data transmission systems, at speeds not exceeding 100 Bd for FSK and 200 Bd for PSK <i>b)</i>							<b>22 443.5</b>   <i>1 f.</i> <i>0.5 kHz</i>	
Limits (kHz)	4 219.25	6 330.75	8 436.25	12 656.75	16 902.75	19 703.25	22 443.75	26 120.75
Frequencies assignable to coast stations for digital selective calling <i>l)</i>	<b>4 219.5</b> to <b>4 220.5</b>  <i>3 f.</i> <i>0.5 kHz</i>	<b>6 331</b> to <b>6 332</b>  <i>3 f.</i> <i>0.5 kHz</i>	<b>8 436.5</b> to <b>8 437.5</b>  <i>3 f.</i> <i>0.5 kHz</i>	<b>12 657</b> to <b>12 658</b>  <i>3 f.</i> <i>0.5 kHz</i>	<b>16 903</b> to <b>16 904</b>  <i>3 f.</i> <i>0.5 kHz</i>	<b>19 703.5</b> to <b>19 704.5</b>  <i>3 f.</i> <i>0.5 kHz</i>	<b>22 444</b> to <b>22 445</b>  <i>3 f.</i> <i>0.5 kHz</i>	<b>26 121</b> to <b>26 122</b>  <i>3 f.</i> <i>0.5 kHz</i>
Limits (kHz)	4 221	6 332.5	8 438	12 658.5	16 904.5	19 705	22 445.5	26 122.5

**Table of frequencies (kHz) to be used in the band between 4 000 kHz and 27 500 kHz allocated exclusively to the maritime mobile service (end)**

<b>Band (MHz)</b>	<b>4</b>	<b>6</b>	<b>8</b>	<b>12</b>	<b>16</b>	<b>18/19</b>	<b>22</b>	<b>25/26</b>
Limits (kHz)	4 221	6 332.5	8 438	12 658.5	16 904.5	19 705	22 445.5	26 122.5
Frequencies assignable for wide-band systems, facsimile, special and data transmission systems and direct-printing telegraphy systems <i>m) p) s) pp)</i>								
Limits (kHz)	4 351	6 501	8 707	13 077	17 242	19 755	22 696	26 145
Frequencies assignable to coast stations for telephony, duplex operation <i>a) t)</i>	<b>4 352.4</b> to <b>4 436.4</b>  <i>29 f.</i> <i>3 kHz</i>	<b>6 502.4</b> to <b>6 523.4</b>  <i>8 f.</i> <i>3 kHz</i>	<b>8 708.4</b> to <b>8 813.4</b>  <i>36 f.</i> <i>3 kHz</i>	<b>13 078.4</b> to <b>13 198.4</b>  <i>41 f.</i> <i>3 kHz</i>	<b>17 243.4</b> to <b>17 408.4</b>  <i>56 f.</i> <i>3 kHz</i>	<b>19 756.4</b> to <b>19 798.4</b>  <i>15 f.</i> <i>3 kHz</i>	<b>22 697.4</b> to <b>22 853.4</b>  <i>53 f.</i> <i>3 kHz</i>	<b>26 146.4</b> to <b>26 173.4</b>  <i>10 f.</i> <i>3 kHz</i>
Limits (kHz)	4 438	6 525	8 815	13 200	17 410	19 800	22 855	26 175

- a) See Part B, Section I.
- b) See Part B, Section III.
- c) The frequency bands may also be used by buoy stations for oceanographic data transmission and by stations interrogating these buoys.
- d) See Part B, Section II.
- e) See Part B, Section IV.
- i) For the use of the carrier frequencies 4 125 kHz, 6 215 kHz, 8 291 kHz, 12 290 kHz and 16 420 kHz in these sub-bands by ship and coast stations for distress and safety purposes, by single-sideband radiotelephony, see Article 31.
- j) For the use of the assigned frequencies 4 177.5 kHz, 6 268 kHz, 8 376.5 kHz, 12 520 kHz and 16 695 kHz in these sub-bands by ship and coast stations for distress and safety purposes, by NBDP telegraphy, see Article 31.
- k) For the use of the assigned frequencies 4 207.5 kHz, 6 312 kHz, 8 414.5 kHz, 12 577 kHz and 16 804.5 kHz in these sub-bands by ship and coast stations for distress and safety purposes, by digital selective calling, see Article 31.
- l) The following paired assigned frequencies (for ship/coast stations) 4 208/4 219.5 kHz, 6 312.5/6 331 kHz, 8 415/8 436.5 kHz, 12 577.5/12 657 kHz, 16 805/16 903 kHz, 18 898.5/19 703.5 kHz, 22 374.5/22 444 kHz and 25 208.5/26 121 kHz are the first choice international frequencies for digital selective calling (see Article 54).
- m) Frequencies from these frequency bands may also be used for A1A or A1B Morse telegraphy subject to not claiming protection from other stations in the maritime mobile service using digitally modulated emissions. Any frequencies so assigned shall be multiples of 100 Hz. Administrations shall ensure a uniform distribution of such assignments within the bands.
- n) The assigned frequencies 4 210 kHz, 6 314 kHz, 8 416.5 kHz, 12 579 kHz, 16 806.5 kHz, 19 680.5 kHz, 22 376 kHz and 26 100.5 kHz are the exclusive international frequencies for the transmission of maritime safety information (MSI) (see Articles 31 and 33).
- o) The frequency 4 209.5 kHz is an exclusive international frequency for the transmission of NAVTEX type information (see Articles 31 and 33).

- p*) These sub-bands, except the frequencies referred to in Notes *i*), *j*), *n*) and *o*), are designated for digitally modulated emissions in the maritime mobile service (e.g. as described in the most recent version of Recommendation ITU-R M.1798). The provisions of No. **15.8** apply. (WRC-15)
- pp*) The frequency bands 4 221-4 231 kHz, 6 332.5-6 342.5 kHz, 8 438-8 448 kHz, 12 658.5-12 668.5 kHz, 16 904.5-16 914.5 kHz and 22 445.5-22 455.5 kHz may also be used by the NAVDAT system, on condition that the use of NAVDAT system transmitting stations is limited to coast stations operating in accordance with the most recent version of Recommendation ITU-R M.2058. (WRC-19)
- q*) These frequency bands may be used by narrow-band direct-printing applications by administrations, subject to not claiming protection from other stations in the maritime mobile service using digitally modulated emissions.
- r*) Frequencies in these bands may be used for wide-band telegraphy, facsimile and special data transmission on the condition that interference is not caused to and protection is not claimed from stations in the maritime mobile service using digitally modulated emissions.
- s*) The frequency bands 4 345-4 351 kHz, 6 495-6 501 kHz, 8 701-8 707 kHz may be used for simplex (single-sideband) telephone operation (regularly spaced by 3 kHz), in accordance with provision No. **52.177**, subject to not claiming protection from other stations in the maritime mobile service using digitally modulated emissions.
- t*) The frequency bands 4 065-4 146 kHz, 4 351-4 438 kHz, 6 200-6 224 kHz, 6 501-6 525 kHz, 8 195-8 294 kHz, 8 707-8 815 kHz, 12 230-12 353 kHz, 13 077-13 200 kHz, 16 360-16 528 kHz, 17 242-17 410 kHz, 18 780-18 825 kHz, 19 755-19 800 kHz, 22 000-22 159 kHz, 22 696-22 855 kHz, 25 070-25 100 kHz and 26 145-26 175 kHz may be used, in accordance with the Appendix **25** allotment Plan, for digitally modulated emissions as described in the most recent version of Recommendation ITU-R M.1798 on the condition that it shall not cause harmful interference to, or claim protection from other stations in the maritime mobile service using radiotelephony operations. The digitally modulated emissions may be used provided that their occupied bandwidth does not exceed 2 800 Hz, it is situated wholly within one frequency channel and the peak envelope power of coast stations does not exceed 10 kW and the peak envelope power of ship stations does not exceed 1.5 kW per channel. (WRC-15)
- u*) These frequency bands may be used for wide-band digitally modulated emissions by combining multiple 3 kHz contiguous channels.
- v*) The frequency bands 4 146-4 152 kHz, 6 224-6 233 kHz, 8 294-8 300 kHz, 12 353-12 368 kHz, 16 528-16 549 kHz, 18 825-18 846 kHz, 22 159-22 180 and 25 100-25 121 kHz may be used for simplex digitally modulated emissions as described in the most recent version of Recommendation ITU-R M.1798 on condition that it shall not cause harmful interference to, or claim protection from other stations in the maritime mobile service using radiotelephony operations. The digitally modulated emissions may be used provided that their occupied bandwidth does not exceed 2 800 Hz, it is situated wholly within one frequency channel and the peak envelope power of coast stations does not exceed 10 kW and the peak envelope power of ship stations does not exceed 1.5 kW per channel. (WRC-15)
- w*) (SUP WRC-19)

**PART B – Channelling arrangements** (WRC-15)

**Section I – Radiotelephony**

1 Radiotelephone channelling arrangements for the frequencies to be used by coast and ship stations in the bands allocated to the maritime mobile service are indicated in the following Sub-Sections:

*Sub-Section A* – Table of single-sideband transmitting frequencies (kHz) for duplex (two-frequency) operation;

*Sub-Section B* – Table of single-sideband transmitting frequencies (kHz) for simplex (single-frequency) operation and for intership cross-band (two-frequency) operation;

*Sub-Section C-1* – Table of recommended single-sideband transmitting frequencies (kHz) for ship stations in the frequency band 4 000-4 063 kHz shared with the fixed service;

*Sub-Section C-2* – Table of recommended single-sideband transmitting frequencies (kHz) for ship and coast stations in the frequency band 8 100-8 195 kHz shared with the fixed service.

2 The technical characteristics for single-sideband transmitters specified in Recommendation ITU-R M.1173-1 shall be used. (WRC-15)

3 One or more series of frequencies from Sub-Section A (with the exception of those frequencies mentioned in § 5 below) may be assigned to each coast station, which uses these frequencies associated in pairs (see No. **52.226**); each pair consists of a transmitting and a receiving frequency. The series shall be selected with due regard to the areas served and so as to avoid, as far as possible, harmful interference between the services of different coast stations.

4 The frequencies in Sub-Section B are provided for worldwide common use by ships of all categories, according to traffic requirements, for ship transmissions to coast stations and for intership communication. They are also authorized for worldwide common use for transmissions by coast stations (simplex operation) provided the peak envelope power does not exceed 1 kW.

5 The following frequencies in Sub-Section A are allocated for calling purposes:

- Channel No. 421 in the 4 MHz band;
- Channel No. 606 in the 6 MHz band;
- Channel No. 821 in the 8 MHz band;
- Channel No. 1221 in the 12 MHz band;

- Channel No. 1621 in the 16 MHz band;
- Channel No. 1806 in the 18 MHz band;
- Channel No. 2221 in the 22 MHz band;
- Channel No. 2510 in the 25 MHz band.

Calling on the carrier frequencies 12 290 kHz and 16 420 kHz shall be permitted only to and from rescue coordination centres (see No. **30.6.1**), subject to the safeguards of Resolution **352 (WRC-03)** (see Nos. **52.221A** and **52.222A**).

The remaining frequencies in Sub-Sections A, B, C-1 and C-2 are working frequencies.

5A For the use of the carrier frequencies:

- 4 125 kHz (Channel No. 421);
- 6 215 kHz (Channel No. 606);
- 8 291 kHz (Channel No. 833);
- 12 290 kHz (Channel No. 1221);
- 16 420 kHz (Channel No. 1621);

in Sub-Section A, by coast and ship stations for distress and safety purposes, see Article **31**.

6 *a)* Maritime radiotelephone stations using single-sideband emissions in the frequency bands between 4 000 kHz and 27 500 kHz exclusively allocated to the maritime mobile service shall operate only on the carrier frequencies shown in the Sub-Sections A and B and, in the case of analogue radiotelephony, shall be in conformity with the technical characteristics specified in Recommendation ITU-R M.1173-1. (WRC-15)

*b)* Ship stations, when using frequencies for single-sideband emissions in the frequency band 4 000-4 063 kHz, and ship and coast stations, when using frequencies for single-sideband emissions in the frequency band 8 100-8 195 kHz, should operate on the carrier frequencies indicated in Sub-Sections C-1 and C-2 respectively. In the case of analogue radiotelephony technical characteristics of the equipment shall be those specified in Recommendation ITU-R M.1173-1. (WRC-15)

*c)* Stations, when employing the single-sideband mode for analogue radiotelephony, shall use only class J3E emissions. For digital communications, class J2D emissions shall be used.

7 The channelling plan established in Sub-Section C-2 does not prejudice the rights of administrations to establish, and to notify assignments to stations in the maritime mobile service other than those using radiotelephony in the frequency band 8 100-8 195 kHz, in conformity with the relevant provisions of these Regulations.

**Sub-Section A**

**Table of single-sideband transmitting frequencies (kHz) for duplex (two-frequency) operation**

Channel No.	4 MHz band			
	Coast stations		Ship stations	
	Carrier frequency	Assigned frequency	Carrier frequency	Assigned frequency
401	4 357	4 358.4	4 065	4 066.4
402	4 360	4 361.4	4 068	4 069.4
403	4 363	4 364.4	4 071	4 072.4
404	4 366	4 367.4	4 074	4 075.4
405	4 369	4 370.4	4 077	4 078.4
406	4 372	4 373.4	4 080	4 081.4
407	4 375	4 376.4	4 083	4 084.4
408	4 378	4 379.4	4 086	4 087.4
409	4 381	4 382.4	4 089	4 090.4
410	4 384	4 385.4	4 092	4 093.4
411	4 387	4 388.4	4 095	4 096.4
412	4 390	4 391.4	4 098	4 099.4
413	4 393	4 394.4	4 101	4 102.4
414	4 396	4 397.4	4 104	4 105.4
415	4 399	4 400.4	4 107	4 108.4
416	4 402	4 403.4	4 110	4 111.4
417	4 405	4 406.4	4 113	4 114.4
418	4 408	4 409.4	4 116	4 117.4
419	4 411	4 412.4	4 119	4 120.4
420	4 414	4 415.4	4 122	4 123.4
421	4 417 *	4 418.4 *	4 125 * <sup>3</sup>	4 126.4 *
422	4 420	4 421.4	4 128	4 129.4
423	4 423	4 424.4	4 131	4 132.4
424	4 426	4 427.4	4 134	4 135.4
425	4 429	4 430.4	4 137	4 138.4
426	4 432	4 433.4	4 140	4 141.4
427	4 435	4 436.4	4 143	4 144.4
428 <sup>1,2</sup>	4 351	4 352.4	—	—
429 <sup>1,2</sup>	4 354	4 355.4	—	—

Channel No.	6 MHz band			
	Coast stations		Ship stations	
	Carrier frequency	Assigned frequency	Carrier frequency	Assigned frequency
601	6 501	6 502.4	6 200	6 201.4
602	6 504	6 505.4	6 203	6 204.4
603	6 507	6 508.4	6 206	6 207.4
604	6 510	6 511.4	6 209	6 210.4
605	6 513	6 514.4	6 212	6 213.4
606	6 516 *	6 517.4 *	6 215 * <sup>4</sup>	6 216.4 *
607	6 519	6 520.4	6 218	6 219.4
608	6 522	6 523.4	6 221	6 222.4

Channel No.	8 MHz band			
	Coast stations		Ship stations	
	Carrier frequency	Assigned frequency	Carrier frequency	Assigned frequency
801	8 719	8 720.4	8 195	8 196.4
802	8 722	8 723.4	8 198	8 199.4
803	8 725	8 726.4	8 201	8 202.4
804	8 728	8 729.4	8 204	8 205.4
805	8 731	8 732.4	8 207	8 208.4
806	8 734	8 735.4	8 210	8 211.4
807	8 737	8 738.4	8 213	8 214.4
808	8 740	8 741.4	8 216	8 217.4
809	8 743	8 744.4	8 219	8 220.4
810	8 746	8 747.4	8 222	8 223.4
811	8 749	8 750.4	8 225	8 226.4
812	8 752	8 753.4	8 228	8 229.4
813	8 755	8 756.4	8 231	8 232.4
814	8 758	8 759.4	8 234	8 235.4
815	8 761	8 762.4	8 237	8 238.4
816	8 764	8 765.4	8 240	8 241.4
817	8 767	8 768.4	8 243	8 244.4
818	8 770	8 771.4	8 246	8 247.4
819	8 773	8 774.4	8 249	8 250.4
820	8 776	8 777.4	8 252	8 253.4
821	8 779 *	8 780.4 *	8 255 *	8 256.4 *
822	8 782	8 783.4	8 258	8 259.4
823	8 785	8 786.4	8 261	8 262.4
824	8 788	8 789.4	8 264	8 265.4
825	8 791	8 792.4	8 267	8 268.4
826	8 794	8 795.4	8 270	8 271.4
827	8 797	8 798.4	8 273	8 274.4
828	8 800	8 801.4	8 276	8 277.4
829	8 803	8 804.4	8 279	8 280.4
830	8 806	8 807.4	8 282	8 283.4
831	8 809	8 810.4	8 285	8 286.4
832	8 812	8 813.4	8 288	8 289.4
833	8 291 <sup>6</sup>	8 292.4	8 291 <sup>6</sup>	8 292.4
834 <sup>2,5</sup>	8 707	8 708.4	—	—
835 <sup>2,5</sup>	8 710	8 711.4	—	—
836 <sup>2,5</sup>	8 713	8 714.4	—	—
837 <sup>2,5</sup>	8 716	8 717.4	—	—



Channel No.	12 MHz band			
	Coast stations		Ship stations	
	Carrier frequency	Assigned frequency	Carrier frequency	Assigned frequency
1201	13 077	13 078.4	12 230	12 231.4
1202	13 080	13 081.4	12 233	12 234.4
1203	13 083	13 084.4	12 236	12 237.4
1204	13 086	13 087.4	12 239	12 240.4
1205	13 089	13 090.4	12 242	12 243.4
1206	13 092	13 093.4	12 245	12 246.4
1207	13 095	13 096.4	12 248	12 249.4
1208	13 098	13 099.4	12 251	12 252.4
1209	13 101	13 102.4	12 254	12 255.4
1210	13 104	13 105.4	12 257	12 258.4
1211	13 107	13 108.4	12 260	12 261.4
1212	13 110	13 111.4	12 263	12 264.4
1213	13 113	13 114.4	12 266	12 267.4
1214	13 116	13 117.4	12 269	12 270.4
1215	13 119	13 120.4	12 272	12 273.4
1216	13 122	13 123.4	12 275	12 276.4
1217	13 125	13 126.4	12 278	12 279.4
1218	13 128	13 129.4	12 281	12 282.4
1219	13 131	13 132.4	12 284	12 285.4
1220	13 134	13 135.4	12 287	12 288.4
1221	13 137 *	13 138.4 *	12 290 *7	12 291.4 *
1222	13 140	13 141.4	12 293	12 294.4
1223	13 143	13 144.4	12 296	12 297.4
1224	13 146	13 147.4	12 299	12 300.4
1225	13 149	13 150.4	12 302	12 303.4
1226	13 152	13 153.4	12 305	12 306.4
1227	13 155	13 156.4	12 308	12 309.4
1228	13 158	13 159.4	12 311	12 312.4
1229	13 161	13 162.4	12 314	12 315.4
1230	13 164	13 165.4	12 317	12 318.4
1231	13 167	13 168.4	12 320	12 321.4
1232	13 170	13 171.4	12 323	12 324.4
1233	13 173	13 174.4	12 326	12 327.4
1234	13 176	13 177.4	12 329	12 330.4
1235	13 179	13 180.4	12 332	12 333.4
1236	13 182	13 183.4	12 335	12 336.4
1237	13 185	13 186.4	12 338	12 339.4
1238	13 188	13 189.4	12 341	12 342.4
1239	13 191	13 192.4	12 344	12 345.4
1240	13 194	13 195.4	12 347	12 348.4
1241	13 197	13 198.4	12 350	12 351.4

Channel No.	16 MHz band			
	Coast stations		Ship stations	
	Carrier frequency	Assigned frequency	Carrier frequency	Assigned frequency
1601	17242	17243.4	16360	16361.4
1602	17245	17246.4	16363	16364.4
1603	17248	17249.4	16366	16367.4
1604	17251	17252.4	16369	16370.4
1605	17254	17255.4	16372	16373.4
1606	17257	17258.4	16375	16376.4
1607	17260	17261.4	16378	16379.4
1608	17263	17264.4	16381	16382.4
1609	17266	17267.4	16384	16385.4
1610	17269	17270.4	16387	16388.4
1611	17272	17273.4	16390	16391.4
1612	17275	17276.4	16393	16394.4
1613	17278	17279.4	16396	16397.4
1614	17281	17282.4	16399	16400.4
1615	17284	17285.4	16402	16403.4
1616	17287	17288.4	16405	16406.4
1617	17290	17291.4	16408	16409.4
1618	17293	17294.4	16411	16412.4
1619	17296	17297.4	16414	16415.4
1620	17299	17300.4	16417	16418.4
1621	17302 *	17303.4 *	16420 * 8	16421.4 *
1622	17305	17306.4	16423	16424.4
1623	17308	17309.4	16426	16427.4
1624	17311	17312.4	16429	16430.4
1625	17314	17315.4	16432	16433.4
1626	17317	17318.4	16435	16436.4
1627	17320	17321.4	16438	16439.4
1628	17323	17324.4	16441	16442.4
1629	17326	17327.4	16444	16445.4
1630	17329	17330.4	16447	16448.4
1631	17332	17333.4	16450	16451.4
1632	17335	17336.4	16453	16454.4
1633	17338	17339.4	16456	16457.4
1634	17341	17342.4	16459	16460.4
1635	17344	17345.4	16462	16463.4
1636	17347	17348.4	16465	16466.4
1637	17350	17351.4	16468	16469.4
1638	17353	17354.4	16471	16472.4
1639	17356	17357.4	16474	16475.4
1640	17359	17360.4	16477	16478.4
1641	17362	17363.4	16480	16481.4
1642	17365	17366.4	16483	16484.4
1643	17368	17369.4	16486	16487.4
1644	17371	17372.4	16489	16490.4
1645	17374	17375.4	16492	16493.4
1646	17377	17378.4	16495	16496.4
1647	17380	17381.4	16498	16499.4
1648	17383	17384.4	16501	16502.4
1649	17386	17387.4	16504	16505.4
1650	17389	17390.4	16507	16508.4
1651	17392	17393.4	16510	16511.4
1652	17395	17396.4	16513	16514.4
1653	17398	17399.4	16516	16517.4
1654	17401	17402.4	16519	16520.4
1655	17404	17405.4	16522	16523.4
1656	17407	17408.4	16525	16526.4

Channel No.	18/19 MHz band			
	Coast stations		Ship stations	
	Carrier frequency	Assigned frequency	Carrier frequency	Assigned frequency
1801	19 755	19 756.4	18 780	18 781.4
1802	19 758	19 759.4	18 783	18 784.4
1803	19 761	19 762.4	18 786	18 787.4
1804	19 764	19 765.4	18 789	18 790.4
1805	19 767	19 768.4	18 792	18 793.4
1806	19 770 *	19 771.4 *	18 795 *	18 796.4 *
1807	19 773	19 774.4	18 798	18 799.4
1808	19 776	19 777.4	18 801	18 802.4
1809	19 779	19 780.4	18 804	18 805.4
1810	19 782	19 783.4	18 807	18 808.4
1811	19 785	19 786.4	18 810	18 811.4
1812	19 788	19 789.4	18 813	18 814.4
1813	19 791	19 792.4	18 816	18 817.4
1814	19 794	19 795.4	18 819	18 820.4
1815	19 797	19 798.4	18 822	18 823.4

Channel No.	22 MHz band			
	Coast stations		Ship stations	
	Carrier frequency	Assigned frequency	Carrier frequency	Assigned frequency
2201	22 696	22 697.4	22 000	22 001.4
2202	22 699	22 700.4	22 003	22 004.4
2203	22 702	22 703.4	22 006	22 007.4
2204	22 705	22 706.4	22 009	22 010.4
2205	22 708	22 709.4	22 012	22 013.4
2206	22 711	22 712.4	22 015	22 016.4
2207	22 714	22 715.4	22 018	22 019.4
2208	22 717	22 718.4	22 021	22 022.4
2209	22 720	22 721.4	22 024	22 025.4
2210	22 723	22 724.4	22 027	22 028.4
2211	22 726	22 727.4	22 030	22 031.4
2212	22 729	22 730.4	22 033	22 034.4
2213	22 732	22 733.4	22 036	22 037.4
2214	22 735	22 736.4	22 039	22 040.4
2215	22 738	22 739.4	22 042	22 043.4
2216	22 741	22 742.4	22 045	22 046.4
2217	22 744	22 745.4	22 048	22 049.4
2218	22 747	22 748.4	22 051	22 052.4
2219	22 750	22 751.4	22 054	22 055.4
2220	22 753	22 754.4	22 057	22 058.4
2221	22 756 *	22 757.4 *	22 060 *	22 061.4 *
2222	22 759	22 760.4	22 063	22 064.4
2223	22 762	22 763.4	22 066	22 067.4
2224	22 765	22 766.4	22 069	22 070.4
2225	22 768	22 769.4	22 072	22 073.4

Channel No.	22 MHz band (end)			
	Coast stations		Ship stations	
	Carrier frequency	Assigned frequency	Carrier frequency	Assigned frequency
2226	22 771	22 772.4	22 075	22 076.4
2227	22 774	22 775.4	22 078	22 079.4
2228	22 777	22 778.4	22 081	22 082.4
2229	22 780	22 781.4	22 084	22 085.4
2230	22 783	22 784.4	22 087	22 088.4
2231	22 786	22 787.4	22 090	22 091.4
2232	22 789	22 790.4	22 093	22 094.4
2233	22 792	22 793.4	22 096	22 097.4
2234	22 795	22 796.4	22 099	22 100.4
2235	22 798	22 799.4	22 102	22 103.4
2236	22 801	22 802.4	22 105	22 106.4
2237	22 804	22 805.4	22 108	22 109.4
2238	22 807	22 808.4	22 111	22 112.4
2239	22 810	22 811.4	22 114	22 115.4
2240	22 813	22 814.4	22 117	22 118.4
2241	22 816	22 817.4	22 120	22 121.4
2242	22 819	22 820.4	22 123	22 124.4
2243	22 822	22 823.4	22 126	22 127.4
2244	22 825	22 826.4	22 129	22 130.4
2245	22 828	22 829.4	22 132	22 133.4
2246	22 831	22 832.4	22 135	22 136.4
2247	22 834	22 835.4	22 138	22 139.4
2248	22 837	22 838.4	22 141	22 142.4
2249	22 840	22 841.4	22 144	22 145.4
2250	22 843	22 844.4	22 147	22 148.4
2251	22 846	22 847.4	22 150	22 151.4
2252	22 849	22 850.4	22 153	22 154.4
2253	22 852	22 853.4	22 156	22 157.4

Channel No.	25/26 MHz band			
	Coast stations		Ship stations	
	Carrier frequency	Assigned frequency	Carrier frequency	Assigned frequency
2501	26 145	26 146.4	25 070	25 071.4
2502	26 148	26 149.4	25 073	25 074.4
2503	26 151	26 152.4	25 076	25 077.4
2504	26 154	26 155.4	25 079	25 080.4
2505	26 157	26 158.4	25 082	25 083.4
2506	26 160	26 161.4	25 085	25 086.4
2507	26 163	26 164.4	25 088	25 089.4
2508	26 166	26 167.4	25 091	25 092.4
2509	26 169	26 170.4	25 094	25 095.4
2510	26 172 *	26 173.4 *	25 097 *	25 098.4 *

<sup>1</sup> These coast station frequencies may be paired with a ship station frequency from the Table of simplex frequencies for ship and coast stations (see Sub-Section B) or with a frequency from the band 4 000-4 063 kHz (see Sub-Section C-1) to be selected by the administration concerned.

<sup>2</sup> These channels may also be used for simplex (single frequency) operation.

**AP17-16**

- <sup>3</sup> For the conditions of use of the carrier frequency 4 125 kHz, see Nos. **52.224** and **52.225**, and Appendix 15.
- <sup>4</sup> For the conditions of use of the carrier frequency 6 215 kHz, see Appendix 15.
- <sup>5</sup> These coast station frequencies may be paired with a ship station frequency from the Table of simplex frequencies for ship and coast stations (see Sub-Section B) or with a frequency from the band 8 100-8 195 kHz (see Sub-Section C-2) to be selected by the administration concerned.
- <sup>6</sup> For the conditions of use of the carrier frequency 8 291 kHz, see Appendix 15.
- <sup>7</sup> For the conditions of use of the carrier frequency 12 290 kHz, see Nos. **52.221A** and **52.222A** and Appendix 15.
- <sup>8</sup> For the conditions of use of the carrier frequency 16 420 kHz, see Nos. **52.221A** and **52.222A** and Appendix 15.
- \* The frequencies followed by an asterisk are calling frequencies (see Nos. **52.221** and **52.222**).

**Sub-Section B**

**Table of single-sideband transmitting frequencies (kHz) for simplex (single-frequency) operation and for intership cross-band (two-frequency) operation**

(See § 4 of Section I of this Appendix)

4 MHz band <sup>1</sup>		6 MHz band		8 MHz band <sup>2</sup>		12 MHz band <sup>3</sup>	
Carrier frequency	Assigned frequency	Carrier frequency	Assigned frequency	Carrier frequency	Assigned frequency	Carrier frequency	Assigned frequency
4 146	4 147.4	6 224	6 225.4	8 294	8 295.4	12 353	12 354.4
4 149	4 150.4	6 227	6 228.4	8 297	8 298.4	12 356	12 357.4
		6 230	6 231.4			12 362	12 363.4
						12 365	12 366.4

- <sup>1</sup> These frequencies may be used for duplex operation with coast stations operating on Channel Nos. 428 and 429 (see Sub-Section A).
- <sup>2</sup> These frequencies may be used for duplex operation with coast stations operating on Channel Nos. 834 up to and including 837 (see Sub-Section A).
- <sup>3</sup> For use of frequencies 12 359 kHz and 16 537 kHz, see Nos. **52.221A** and **52.222A**.

16 MHz band <sup>3</sup>		18/19 MHz band		22 MHz band		25/26 MHz band	
Carrier frequency	Assigned frequency	Carrier frequency	Assigned frequency	Carrier frequency	Assigned frequency	Carrier frequency	Assigned frequency
16 528	16 529.4	18 825	18 826.4	22 159	22 160.4	25 100	25 101.4
16 531	16 532.4	18 828	18 829.4	22 162	22 163.4	25 103	25 104.4
16 534	16 535.4	18 831	18 832.4	22 165	22 166.4	25 106	25 107.4
		18 834	18 835.4	22 168	22 169.4	25 109	25 110.4
16 540	16 541.4	18 837	18 838.4	22 171	22 172.4	25 112	25 113.4
16 543	16 544.4	18 840	18 841.4	22 174	22 175.4	25 115	25 116.4
16 546	16 547.4	18 843	18 844.4	22 177	22 178.4	25 118	25 119.4

- <sup>3</sup> For use of frequencies 12 359 kHz and 16 537 kHz, see Nos. **52.221A** and **52.222A**.

### Sub-Section C-1

**Table of recommended single-sideband transmitting frequencies (kHz) for ship stations in the band 4 000-4 063 kHz shared with the fixed service**

The frequencies in this Sub-Section may be used:

- for supplementing ship-to-shore channels for duplex operation in Sub-Section A;
- for intership simplex (single-frequency) and cross-band operation;
- for cross-band working with coast stations on channels in Sub-Section C-2;
- for duplex operation with coast stations working in the band 4 438-4 650 kHz;
- for duplex operation with Channel Nos. 428 and 429.

Channel No.	Carrier frequency	Assigned frequency	Channel No.	Carrier frequency	Assigned frequency
1	4 000*	4 001.4*	12	4 033	4 034.4
2	4 003*	4 004.4*	13	4 036	4 037.4
3	4 006	4 007.4	14	4 039	4 040.4
4	4 009	4 010.4	15	4 042	4 043.4
5	4 012	4 013.4	16	4 045	4 046.4
6	4 015	4 016.4	17	4 048	4 049.4
7	4 018	4 019.4	18	4 051	4 052.4
8	4 021	4 022.4	19	4 054	4 055.4
9	4 024	4 025.4	20	4 057	4 058.4
10	4 027	4 028.4	21	4 060	4 061.4
11	4 030	4 031.4			

\* Administrations are requested to urge ship stations under their jurisdiction to refrain from using the band 4 000-4 005 kHz when navigating in Region 3 (see also No. 5.126).

### Sub-Section C-2

**Table of recommended single-sideband transmitting frequencies (kHz) for ship and coast stations in the band 8 100-8 195 kHz shared with the fixed service**

(See § 7 of Section I of this Appendix)

The frequencies in this Sub-Section may be used:

- for supplementing ship-to-shore and shore-to-ship channels for duplex operation in Sub-Section A;
- for intership simplex (single frequency) and cross-band operation;
- for cross-band working with ship stations on channels in Sub-Section C-1;
- for ship-to-shore or shore-to-ship simplex operation;
- for duplex operation with Channel Nos. 834, 835, 836 and 837.

Channel No.	Carrier frequency	Assigned frequency	Channel No.	Carrier frequency	Assigned frequency
1	8 101	8 102.4	17	8 149	8 150.4
2	8 104	8 105.4	18	8 152	8 153.4
3	8 107	8 108.4	19	8 155	8 156.4
4	8 110	8 111.4	20	8 158	8 159.4
5	8 113	8 114.4	21	8 161	8 162.4
6	8 116	8 117.4	22	8 164	8 165.4
7	8 119	8 120.4	23	8 167	8 168.4
8	8 122	8 123.4	24	8 170	8 171.4
9	8 125	8 126.4	25	8 173	8 174.4
10	8 128	8 129.4	26	8 176	8 177.4
11	8 131	8 132.4	27	8 179	8 180.4
12	8 134	8 135.4	28	8 182	8 183.4
13	8 137	8 138.4	29	8 185	8 186.4
14	8 140	8 141.4	30	8 188	8 189.4
15	8 143	8 144.4	31	8 191	8 192.4
16	8 146	8 147.4			

**Section II – Narrow-band direct-printing telegraphy (paired frequencies)**

1 Each coast station which uses paired frequencies is assigned one or more frequency pairs from the following series; each pair consists of a transmitting and a receiving frequency.

2 The speed of the narrow-band direct-printing telegraphy and data systems shall not exceed 100 Bd for FSK and 200 Bd for PSK.

**Table of frequencies for two-frequency operation by coast stations (kHz)**

Channel No.	4 MHz band		6 MHz band		8 MHz band	
	Transmit	Receive	Transmit	Receive	Transmit	Receive
1	4210.5	4 172.5	6314.5	6263	8376.5	8376.5
2	4211	4 173	6315	6263.5	8417	8377
3	4211.5	4 173.5	6315.5	6264	8417.5	8377.5
4	4212	4 174	6316	6264.5	8418	8378
5	4212.5	4 174.5	6316.5	6265	8418.5	8378.5
6	4213	4 175	6317	6265.5	8419	8379
7	4213.5	4 175.5	6317.5	6266	8419.5	8379.5
8	4214	4 176	6318	6266.5	8420	8380
9	4214.5	4 176.5	6318.5	6267	8420.5	8380.5
10	4215	4 177	6319	6267.5	8421	8381
11	4177.5	4 177.5	6268	6268	8421.5	8381.5
12	4215.5	4 178	6319.5	6268.5	8422	8382
13	4216	4 178.5	6320	6269	8422.5	8382.5
14			6320.5	6269.5	8423	8383
15					8423.5	8383.5

Table of frequencies for two-frequency operation by coast stations (kHz)

Channel No.	12 MHz band		16 MHz band		18/19 MHz band	
	Transmit	Receive	Transmit	Receive	Transmit	Receive
1	12 579.5	12 477	16 807	16 683.5		
2	12 580	12 477.5	16 807.5	16 684		
3	12 580.5	12 478	16 808	16 684.5		
4	12 581	12 478.5	16 808.5	16 685		
5	12 581.5	12 479	16 809	16 685.5		
6	12 582	12 479.5	16 809.5	16 686		
7	12 582.5	12 480	16 810	16 686.5	19 684	18 873.5
8	12 583	12 480.5	16 810.5	16 687	19 684.5	18 874
9	12 583.5	12 481	16 811	16 687.5	19 685	18 874.5
10	12 584	12 481.5	16 811.5	16 688	19 685.5	18 875
11	12 584.5	12 482	16 812	16 688.5	19 686	18 875.5
12	12 585	12 482.5	16 812.5	16 689	19 686.5	18 876
13	12 585.5	12 483	16 813	16 689.5	19 687	18 876.5
14	12 586	12 483.5	16 813.5	16 690	19 687.5	18 877
15	12 586.5	12 484	16 814	16 690.5	19 688	18 877.5
16	12 587	12 484.5	16 814.5	16 691	19 688.5	18 878
17	12 587.5	12 485	16 815	16 691.5	19 689	18 878.5
18	12 588	12 485.5	16 815.5	16 692	19 689.5	18 879
19	12 588.5	12 486	16 816	16 692.5	19 690	18 879.5
20	12 589	12 486.5	16 816.5	16 693	19 690.5	18 880
21	12 589.5	12 487	16 817	16 693.5		
22	12 590	12 487.5	16 817.5	16 694		
23	12 590.5	12 488	16 818	16 694.5		
24	12 591	12 488.5	16 695	16 695		
25	12 591.5	12 489	16 818.5	16 695.5		
26	12 592	12 489.5	16 819	16 696		
27	12 592.5	12 490	16 819.5	16 696.5		
28	12 593	12 490.5	16 820	16 697		
29	12 593.5	12 491	16 820.5	16 697.5		
30	12 594	12 491.5	16 821	16 698		
31	12 594.5	12 492	16 821.5	16 698.5		
32	12 595	12 492.5				
33	12 595.5	12 493				
34	12 596	12 493.5				
35	12 596.5	12 494				
36	12 597	12 494.5				
37	12 597.5	12 495				
38	12 598	12 495.5				
39	12 598.5	12 496				
40	12 599	12 496.5				
41	12 599.5	12 497				
42	12 600	12 497.5				
43	12 600.5	12 498				
44	12 601	12 498.5				
45	12 601.5	12 499				



Table of frequencies for two-frequency operation by coast stations (kHz)

Channel No.	12 MHz band ( <i>end</i> )	
	Transmit	Receive
46	12 602	12 499.5
47	12 602.5	12 500
48	12 603	12 500.5
49	12 603.5	12 501
50	12 604	12 501.5
51	12 604.5	12 502
52	12 605	12 502.5
53	12 605.5	12 503
54	12 606	12 503.5
55	12 606.5	12 504
56	12 607	12 504.5
57	12 607.5	12 505
58	12 608	12 505.5
59	12 608.5	12 506
60	12 609	12 506.5
61	12 609.5	12 507
62	12 610	12 507.5
63	12 610.5	12 508
64	12 611	12 508.5
65	12 611.5	12 509
66	12 612	12 509.5
67	12 612.5	12 510
68	12 613	12 510.5
69	12 613.5	12 511
70	12 614	12 511.5
71	12 614.5	12 512
72	12 615	12 512.5
73	12 615.5	12 513
74	12 616	12 513.5
75	12 616.5	12 514
76	12 617	12 514.5
77	12 617.5	12 515
78	12 618	12 515.5
79	12 618.5	12 516
80	12 619	12 516.5
81	12 619.5	12 517
82	12 620	12 517.5
83	12 620.5	12 518
84	12 621	12 518.5
85	12 621.5	12 519
86	12 622	12 519.5
87	12 622.5	12 520
88	12 622.5	12 520.5
89	12 623	12 521
90	12 623.5	12 521.5
91	12 624	12 522
92	12 624.5	12 522.5

Table of frequencies for two-frequency operation by coast stations (kHz)

Channel No.	22 MHz band	
	Transmit	Receive
13	22 382.5	22 290.5
14	22 383	22 291
15	22 383.5	22 291.5
16	22 384	22 292
17	22 384.5	22 292.5
18	22 385	22 293
19	22 385.5	22 293.5
20	22 386	22 294
21	22 386.5	22 294.5
22	22 387	22 295
23	22 387.5	22 295.5
24	22 388	22 296
25	22 388.5	22 296.5
26	22 389	22 297

### Section III – Narrow-band direct-printing telegraphy (non-paired frequencies)

- 1 One or more frequencies are assigned to each ship station as transmitting frequencies.
- 2 All frequencies appearing in this Appendix may be used for NBDP duplex operation.
- 3 The speed of the narrow-band direct-printing telegraphy and data systems shall not exceed 100 Bd for FSK and 200 Bd for PSK.

Frequency bands								
Channel No.	4 MHz	6 MHz	8 MHz	12 MHz	16 MHz	18/19 MHz	22 MHz	25/26 MHz
1	4 170.5	6 260.25	8 339.25	12 419.25	16 615.25	19 691	22 290	26 101
2	4 171	6 260.75	8 339.75	12 419.75	16 615.75		22 297.5	26 101.5
3	4 171.5	6 321	8 375	12 422	16 616.25		22 298	26 102
4	4 172	6 321.5	8 375.5	12 476.5	16 616.75		22 298.5	26 102.5
5	4 179		8 376	12 655	16 682		22 299	
6	4 179.5			12 655.5	16 682.5		22 443.5	
7	4 180			12 656	16 683			
8				12 656.5				

**Section IV – Data transmission**

**Table of frequencies (kHz) assignable to ship and coast stations for data transmission (kHz)<sup>1</sup>**

Channel No.	4 MHz band		6 MHz band		8 MHz band	
	Coast Tx (ship Rx)	Ship Tx/Rx (coast Rx)	Coast Tx (ship Rx)	Ship Tx/Rx (coast Rx)	Coast Tx (ship Rx)	Ship Tx/Rx (coast Rx)
1		4 153.5 <sup>3,4</sup>		6 234.5 <sup>3,4</sup>		8 301.5 <sup>3,4</sup>
2		4 156.5 <sup>3,4</sup>		6 237.5 <sup>3,4</sup>		8 304.5 <sup>3,4</sup>
3		4 159.5 <sup>3,4</sup>		6 240.5 <sup>3,4</sup>		8 307.5 <sup>3,4</sup>
4		4 162.5 <sup>3,4</sup>		6 243.5 <sup>3,4</sup>		8 310.5 <sup>3,4</sup>
5		4 165.5 <sup>3,4</sup>		6 246.5 <sup>3,4</sup>		8 313.5 <sup>3,4</sup>
6		4 168.5 <sup>3,4</sup>		6 249.5 <sup>3,4</sup>		8 316.5 <sup>3,4</sup>
7	4 199.75	4 181.75		6 252.5 <sup>3,4</sup>		8 319.5 <sup>3,4</sup>
8	4 202.75	4 184.75		6 255.5 <sup>3,4</sup>		8 322.5 <sup>3,4</sup>
9	4 205.75	4 187.75		6 258.5 <sup>3,4</sup>		8 325.5 <sup>3,4</sup>
10	4 190.75 <sup>2,3</sup>	4 190.75 <sup>2,3</sup>	6 323.25	6 271.25		8 328.5 <sup>3,4</sup>
11	4 193.75 <sup>2,3</sup>	4 193.75 <sup>2,3</sup>	6 326.25	6 274.25		8 331.5 <sup>3,4</sup>
12	4 196.75 <sup>2,3</sup>	4 196.75 <sup>2,3</sup>	6 329.25	6 277.25		8 334.5 <sup>3,4</sup>
13	4 217.75 <sup>2</sup>	4 217.75 <sup>2</sup>	6 280.25 <sup>2,3</sup>	6 280.25 <sup>2,3</sup>		8 337.5 <sup>3,4</sup>
14			6 283.25 <sup>2,3</sup>	6 283.25 <sup>2,3</sup>	8 409.5	8 343.25
15			6 286.25 <sup>2,3</sup>	6 286.25 <sup>2,3</sup>	8 412.5	8 346.25
16			6 289.25 <sup>2,3</sup>	6 289.25 <sup>2,3</sup>	8 425.5	8 349.25
17			6 292.25 <sup>2,3</sup>	6 292.25 <sup>2,3</sup>	8 428.5 <sup>3</sup>	8 352.25 <sup>3</sup>
18			6 295.25 <sup>2,3</sup>	6 295.25 <sup>2,3</sup>	8 431.5 <sup>3</sup>	8 355.25 <sup>3</sup>
19			6 298.25 <sup>2,3</sup>	6 298.25 <sup>2,3</sup>	8 434.5 <sup>3</sup>	8 358.25 <sup>3</sup>
20			6 301.25 <sup>2,3</sup>	6 301.25 <sup>2,3</sup>	8 361.25 <sup>2,3</sup>	8 361.25 <sup>2,3</sup>
21			6 304.25 <sup>2,3</sup>	6 304.25 <sup>2,3</sup>	8 364.25 <sup>2,3</sup>	8 364.25 <sup>2,3</sup>
22			6 307.25 <sup>2,3</sup>	6 307.25 <sup>2,3</sup>	8 367.25 <sup>2,3</sup>	8 367.25 <sup>2,3</sup>
23			6 310.25 <sup>2,3</sup>	6 310.25 <sup>2,3</sup>	8 370.25 <sup>2,3</sup>	8 370.25 <sup>2,3</sup>
24					8 373.25 <sup>2,3</sup>	8 373.25 <sup>2,3</sup>
25					8 385.5 <sup>2,3</sup>	8 385.5 <sup>2,3</sup>
26					8 388.5 <sup>2,3</sup>	8 388.5 <sup>2,3</sup>
27					8 391.5 <sup>2,3</sup>	8 391.5 <sup>2,3</sup>
28					8 394.5 <sup>2,3</sup>	8 394.5 <sup>2,3</sup>
29					8 397.5 <sup>2,3</sup>	8 397.5 <sup>2,3</sup>
30					8 400.5 <sup>2,3</sup>	8 400.5 <sup>2,3</sup>
31					8 403.5 <sup>2,3</sup>	8 403.5 <sup>2,3</sup>
32					8 406.5 <sup>2,3</sup>	8 406.5 <sup>2,3</sup>

**Table of frequencies (kHz) assignable to ship and coast stations  
for data transmission (kHz)<sup>1</sup>**

Channel No.	12 MHz		16 MHz		18/19 MHz	
	Coast Tx (ship Rx)	Ship Tx/Rx (coast Rx)	Coast Tx (ship Rx)	Ship Tx/Rx (coast Rx)	Coast Tx (ship Rx)	Ship Tx/Rx (coast Rx)
1		12 369.5 <sup>3,4</sup>		16 550.5 <sup>3,4</sup>		18 847.5 <sup>3,4</sup>
2		12 372.5 <sup>3,4</sup>		16 553.5 <sup>3,4</sup>		18 850.5 <sup>3,4</sup>
3		12 375.5 <sup>3,4</sup>		16 556.5 <sup>3,4</sup>		18 853.5 <sup>3,4</sup>
4		12 378.5 <sup>3,4</sup>		16 559.5 <sup>3,4</sup>		18 856.5 <sup>3,4</sup>
5		12 381.5 <sup>3,4</sup>		16 562.5 <sup>3,4</sup>		18 859.5 <sup>3,4</sup>
6		12 384.5 <sup>3,4</sup>		16 565.5 <sup>3,4</sup>		18 862.5 <sup>3,4</sup>
7		12 387.5 <sup>3,4</sup>		16 568.5 <sup>3,4</sup>		18 865.5 <sup>3,4</sup>
8		12 390.5 <sup>3,4</sup>		16 571.5 <sup>3,4</sup>		18 868.5 <sup>3,4</sup>
9		12 393.5 <sup>3,4</sup>		16 574.5 <sup>3,4</sup>		18 871.5 <sup>3,4</sup>
10		12 396.5 <sup>3,4</sup>		16 577.5 <sup>3,4</sup>	19 682.25	18 881.75
11		12 399.5 <sup>3,4</sup>		16 580.5 <sup>3,4</sup>	19 692.75	18 884.75
12		12 402.5 <sup>3,4</sup>		16 583.5 <sup>3,4</sup>	19 695.75 <sup>3</sup>	18 887.75 <sup>3</sup>
13		12 405.5 <sup>3,4</sup>		16 586.5 <sup>3,4</sup>	19 698.75 <sup>3</sup>	18 890.75 <sup>3</sup>
14		12 408.5 <sup>3,4</sup>		16 589.5 <sup>3,4</sup>	19 701.75 <sup>3</sup>	18 893.75 <sup>3</sup>
15		12 411.5 <sup>3,4</sup>		16 592.5 <sup>3,4</sup>	18 896.75 <sup>2</sup>	18 896.75 <sup>2</sup>
16		12 414.5 <sup>3,4</sup>		16 595.5 <sup>3,4</sup>		
17		12 417.5 <sup>3,4</sup>		16 598.5 <sup>3,4</sup>		
18	12 626.25	12 423.75		16 601.5 <sup>3,4</sup>		
19	12 629.25	12 426.75		16 604.5 <sup>3,4</sup>		
20	12 632.25	12 429.75		16 607.5 <sup>3,4</sup>		
21	12 635.25	12 432.75		16 610.5 <sup>3,4</sup>		
22	12 638.25 <sup>3</sup>	12 435.75 <sup>3</sup>		16 613.5 <sup>3,4</sup>		
23	12 641.25 <sup>3</sup>	12 438.75 <sup>3</sup>	16 841.25	16 620.25		
24	12 644.25 <sup>3</sup>	12 441.75 <sup>3</sup>	16 844.25	16 623.25		
25	12 647.25 <sup>3</sup>	12 444.75 <sup>3</sup>	16 847.25	16 626.25		
26	12 650.25 <sup>3</sup>	12 447.75 <sup>3</sup>	16 850.25	16 629.25		
27	12 653.25 <sup>3</sup>	12 450.75 <sup>3</sup>	16 853.25	16 632.25		
28	12 453.75 <sup>2,3</sup>	12 453.75 <sup>2,3</sup>	16 856.25	16 635.25		
29	12 456.75 <sup>2,3</sup>	12 456.75 <sup>2,3</sup>	16 859.25	16 638.25		
30	12 459.75 <sup>2,3</sup>	12 459.75 <sup>2,3</sup>	16 862.25	16 641.25		
31	12 462.75 <sup>2,3</sup>	12 462.75 <sup>2,3</sup>	16 865.25	16 644.25		
32	12 465.75 <sup>2,3</sup>	12 465.75 <sup>2,3</sup>	16 868.25 <sup>3</sup>	16 647.25 <sup>3</sup>		
33	12 468.75 <sup>2,3</sup>	12 468.75 <sup>2,3</sup>	16 871.25 <sup>3</sup>	16 650.25 <sup>3</sup>		
34	12 471.75 <sup>2,3</sup>	12 471.75 <sup>2,3</sup>	16 874.25 <sup>3</sup>	16 653.25 <sup>3</sup>		
35	12 474.75 <sup>2,3</sup>	12 474.75 <sup>2,3</sup>	16 877.25 <sup>3</sup>	16 656.25 <sup>3</sup>		
36	12 524.25 <sup>2,3</sup>	12 524.25 <sup>2,3</sup>	16 880.25 <sup>3</sup>	16 659.25 <sup>3</sup>		
37	12 527.25 <sup>2,3</sup>	12 527.25 <sup>2,3</sup>	16 883.25 <sup>3</sup>	16 662.25 <sup>3</sup>		
38	12 530.25 <sup>2,3</sup>	12 530.25 <sup>2,3</sup>	16 886.25 <sup>3</sup>	16 665.25 <sup>3</sup>		
39	12 533.25 <sup>2,3</sup>	12 533.25 <sup>2,3</sup>	16 889.25 <sup>3</sup>	16 668.25 <sup>3</sup>		
40	12 536.25 <sup>2,3</sup>	12 536.25 <sup>2,3</sup>	16 892.25 <sup>3</sup>	16 671.25 <sup>3</sup>		
41	12 539.25 <sup>2,3</sup>	12 539.25 <sup>2,3</sup>	16 895.25 <sup>3</sup>	16 674.25 <sup>3</sup>		
42	12 542.25 <sup>2,3</sup>	12 542.25 <sup>2,3</sup>	16 898.25 <sup>3</sup>	16 677.25 <sup>3</sup>		
43	12 545.25 <sup>2,3</sup>	12 545.25 <sup>2,3</sup>	16 901.25 <sup>3</sup>	16 680.25 <sup>3</sup>		
44	12 548.25 <sup>2,3</sup>	12 548.25 <sup>2,3</sup>	16 700.5 <sup>2,3</sup>	16 700.5 <sup>2,3</sup>		
45	12 551.25 <sup>2,3</sup>	12 551.25 <sup>2,3</sup>	16 703.5 <sup>2,3</sup>	16 703.5 <sup>2,3</sup>		

Channel No.	12 MHz (end)		16 MHz (end)	
	Coast Tx (ship Rx)	Ship Tx/Rx (coast Rx)	Coast Tx (ship Rx)	Ship Tx/Rx (coast Rx)
46	12 554.25 <sup>2,3</sup>	12 554.25 <sup>2,3</sup>	16 706.5 <sup>2,3</sup>	16 706.5 <sup>2,3</sup>
47	12 557.25 <sup>2,3</sup>	12 557.25 <sup>2,3</sup>	16 709.5 <sup>2,3</sup>	16 709.5 <sup>2,3</sup>
48	12 560.25 <sup>2,3</sup>	12 560.25 <sup>2,3</sup>	16 712.5 <sup>2,3</sup>	16 712.5 <sup>2,3</sup>
49	12 563.25 <sup>2,3</sup>	12 563.25 <sup>2,3</sup>	16 715.5 <sup>2,3</sup>	16 715.5 <sup>2,3</sup>
50	12 566.25 <sup>2,3</sup>	12 566.25 <sup>2,3</sup>	16 718.5 <sup>2,3</sup>	16 718.5 <sup>2,3</sup>
51	12 569.25 <sup>2,3</sup>	12 569.25 <sup>2,3</sup>	16 721.5 <sup>2,3</sup>	16 721.5 <sup>2,3</sup>
52	12 572.25 <sup>2,3</sup>	12 572.25 <sup>2,3</sup>	16 724.5 <sup>2,3</sup>	16 724.5 <sup>2,3</sup>
53	12 575.25 <sup>2,3</sup>	12 575.25 <sup>2,3</sup>	16 727.5 <sup>2,3</sup>	16 727.5 <sup>2,3</sup>
54			16 730.5 <sup>2,3</sup>	16 730.5 <sup>2,3</sup>
55			16 733.5 <sup>2,3</sup>	16 733.5 <sup>2,3</sup>
56			16 736.5 <sup>2,3</sup>	16 736.5 <sup>2,3</sup>
57			16 739.5 <sup>2,3</sup>	16 739.5 <sup>2,3</sup>
58			16 742.5 <sup>2,3</sup>	16 742.5 <sup>2,3</sup>
59			16 745.5 <sup>2,3</sup>	16 745.5 <sup>2,3</sup>
60			16 748.5 <sup>2,3</sup>	16 748.5 <sup>2,3</sup>
61			16 751.5 <sup>2,3</sup>	16 751.5 <sup>2,3</sup>
62			16 754.5 <sup>2,3</sup>	16 754.5 <sup>2,3</sup>
63			16 757.5 <sup>2,3</sup>	16 757.5 <sup>2,3</sup>
64			16 760.5 <sup>2,3</sup>	16 760.5 <sup>2,3</sup>
65			16 763.5 <sup>2,3</sup>	16 763.5 <sup>2,3</sup>
66			16 766.5 <sup>2,3</sup>	16 766.5 <sup>2,3</sup>
67			16 769.5 <sup>2,3</sup>	16 769.5 <sup>2,3</sup>
68			16 772.5 <sup>2,3</sup>	16 772.5 <sup>2,3</sup>
69			16 775.5 <sup>2,3</sup>	16 775.5 <sup>2,3</sup>
70			16 778.5 <sup>2,3</sup>	16 778.5 <sup>2,3</sup>
71			16 781.5 <sup>2,3</sup>	16 781.5 <sup>2,3</sup>
72			16 784.5 <sup>2,3</sup>	16 784.5 <sup>2,3</sup>
73			16 787.5 <sup>2,3</sup>	16 787.5 <sup>2,3</sup>
74			16 790.5 <sup>2,3</sup>	16 790.5 <sup>2,3</sup>
75			16 793.5 <sup>2,3</sup>	16 793.5 <sup>2,3</sup>
76			16 796.5 <sup>2,3</sup>	16 796.5 <sup>2,3</sup>
77			16 799.5 <sup>2,3</sup>	16 799.5 <sup>2,3</sup>
78			16 802.5 <sup>2,3</sup>	16 802.5 <sup>2,3</sup>
79			16 823.25 <sup>2,3</sup>	16 823.25 <sup>2,3</sup>
80			16 826.25 <sup>2,3</sup>	16 826.25 <sup>2,3</sup>
81			16 829.25 <sup>2,3</sup>	16 829.25 <sup>2,3</sup>
82			16 832.25 <sup>2,3</sup>	16 832.25 <sup>2,3</sup>
83			16 835.25 <sup>2,3</sup>	16 835.25 <sup>2,3</sup>
84			16 838.25 <sup>2,3</sup>	16 838.25 <sup>2,3</sup>

**Table of frequencies (kHz) assignable to ship and coast stations  
for data transmission (kHz)<sup>1</sup>**

Channel No.	22 MHz		25/26 MHz	
	Coast Tx (ship Rx)	Ship Tx/Rx (coast Rx)	Coast Tx (ship Rx)	Ship Tx/Rx (coast Rx)
1		22 181.5 <sup>3,4</sup>		25 122.5 <sup>3,4</sup>
2		22 184.5 <sup>3,4</sup>		25 125.5 <sup>3,4</sup>
3		22 187.5 <sup>3,4</sup>		25 128.5 <sup>3,4</sup>
4		22 190.5 <sup>3,4</sup>		25 131.5 <sup>3,4</sup>
5		22 193.5 <sup>3,4</sup>		25 134.5 <sup>3,4</sup>
6		22 196.5 <sup>3,4</sup>		25 137.5 <sup>3,4</sup>
7		22 199.5 <sup>3,4</sup>		25 140.5 <sup>3,4</sup>
8		22 202.5 <sup>3,4</sup>		25 143.5 <sup>3,4</sup>
9		22 205.5 <sup>3,4</sup>		25 146.5 <sup>3,4</sup>
10		22 208.5 <sup>3,4</sup>		25 149.5 <sup>3,4</sup>
11		22 211.5 <sup>3,4</sup>		25 152.5 <sup>3,4</sup>
12		22 214.5 <sup>3,4</sup>		25 155.5 <sup>3,4</sup>
13		22 217.5 <sup>3,4</sup>		25 158.5 <sup>3,4</sup>
14		22 220.5 <sup>3,4</sup>	26 104.25	25 161.5
15		22 223.5 <sup>3,4</sup>	26 107.25	25 164.5
16		22 226.5 <sup>3,4</sup>	26 110.25	25 167.5
17		22 229.5 <sup>3,4</sup>	26 113.25 <sup>3</sup>	25 170.5 <sup>3</sup>
18		22 232.5 <sup>3,4</sup>	26 116.25 <sup>3</sup>	25 173.5 <sup>3</sup>
19		22 235.5 <sup>3,4</sup>	26 119.25 <sup>3</sup>	25 176.5 <sup>3</sup>
20		22 238.5 <sup>3,4</sup>	25 179.5 <sup>2,3</sup>	25 179.5 <sup>2,3</sup>
21	22 390.75	22 243.25	25 182.5 <sup>2,3</sup>	25 182.5 <sup>2,3</sup>
22	22 393.75	22 246.25	25 185.5 <sup>2,3</sup>	25 185.5 <sup>2,3</sup>
23	22 396.75	22 249.25	25 188.5 <sup>2,3</sup>	25 188.5 <sup>2,3</sup>
24	22 399.75	22 252.25	25 191.5 <sup>2,3</sup>	25 191.5 <sup>2,3</sup>
25	22 402.75	22 255.25	25 194.5 <sup>2,3</sup>	25 194.5 <sup>2,3</sup>
26	22 405.75	22 258.25	25 197.5 <sup>2,3</sup>	25 197.5 <sup>2,3</sup>
27	22 408.75 <sup>3</sup>	22 261.25 <sup>3</sup>	25 200.5 <sup>2,3</sup>	25 200.5 <sup>2,3</sup>
28	22 411.75 <sup>3</sup>	22 264.25 <sup>3</sup>	25 203.5 <sup>2,3</sup>	25 203.5 <sup>2,3</sup>
29	22 414.75 <sup>3</sup>	22 267.25 <sup>3</sup>	25 206.5 <sup>2,3</sup>	25 206.5 <sup>2,3</sup>
30	22 417.75 <sup>3</sup>	22 270.25 <sup>3</sup>		
31	22 420.75 <sup>3</sup>	22 273.25 <sup>3</sup>		
32	22 423.75 <sup>3</sup>	22 276.25 <sup>3</sup>		
33	22 426.75 <sup>3</sup>	22 279.25 <sup>3</sup>		
34	22 429.75 <sup>3</sup>	22 282.25 <sup>3</sup>		
35	22 432.75 <sup>3</sup>	22 285.25 <sup>3</sup>		
36	22 435.75 <sup>3</sup>	22 288.25 <sup>3</sup>		
37	22 300.75 <sup>2,3</sup>	22 300.75 <sup>2,3</sup>		
38	22 303.75 <sup>2,3</sup>	22 303.75 <sup>2,3</sup>		
39	22 306.75 <sup>2,3</sup>	22 306.75 <sup>2,3</sup>		
40	22 309.75 <sup>2,3</sup>	22 309.75 <sup>2,3</sup>		
41	22 312.75 <sup>2,3</sup>	22 312.75 <sup>2,3</sup>		
42	22 315.75 <sup>2,3</sup>	22 315.75 <sup>2,3</sup>		
43	22 318.75 <sup>2,3</sup>	22 318.75 <sup>2,3</sup>		
44	22 321.75 <sup>2,3</sup>	22 321.75 <sup>2,3</sup>		
45	22 324.75 <sup>2,3</sup>	22 324.75 <sup>2,3</sup>		

Channel No.	22 MHz (end)	
	Coast Tx (ship Rx)	Ship Tx/Rx (coast Rx)
46	22 327.75 <sup>2,3</sup>	22 327.75 <sup>2,3</sup>
47	22 330.75 <sup>2,3</sup>	22 330.75 <sup>2,3</sup>
48	22 333.75 <sup>2,3</sup>	22 333.75 <sup>2,3</sup>
49	22 336.75 <sup>2,3</sup>	22 336.75 <sup>2,3</sup>
50	22 339.75 <sup>2,3</sup>	22 339.75 <sup>2,3</sup>
51	22 342.75 <sup>2,3</sup>	22 342.75 <sup>2,3</sup>
52	22 345.75 <sup>2,3</sup>	22 345.75 <sup>2,3</sup>
53	22 348.75 <sup>2,3</sup>	22 348.75 <sup>2,3</sup>
54	22 351.75 <sup>2,3</sup>	22 351.75 <sup>2,3</sup>
55	22 354.75 <sup>2,3</sup>	22 354.75 <sup>2,3</sup>
56	22 357.75 <sup>2,3</sup>	22 357.75 <sup>2,3</sup>
57	22 360.75 <sup>2,3</sup>	22 360.75 <sup>2,3</sup>
58	22 363.75 <sup>2,3</sup>	22 363.75 <sup>2,3</sup>
59	22 366.75 <sup>2,3</sup>	22 366.75 <sup>2,3</sup>
60	22 369.75 <sup>2,3</sup>	22 369.75 <sup>2,3</sup>
61	22 372.75 <sup>2,3</sup>	22 372.75 <sup>2,3</sup>
62	22 438.75	22 377.75
63	22 441.75	22 380.75

- 1 The data transmission should be in accordance with the most recent version of Recommendation ITU-R M.1798.
- 2 Non-paired (simplex) operations only.
- 3 Assignable for wide-band operation using multiple 3 kHz contiguous channels.
- 4 Channels may be paired with wide-band coast station channels in the same band.

## APPENDIX 18 (REV.WRC-19)

### Table of transmitting frequencies in the VHF maritime mobile band

(See Article 52)

NOTE A – For assistance in understanding the Table, see Notes *a)* to *zz)* below. (WRC-15)

NOTE B – The Table below defines the channel numbering for maritime VHF communications based on 25 kHz channel spacing and use of several duplex channels. The channel numbering and the conversion of two-frequency channels for single-frequency operation shall be in accordance with Recommendation ITU-R M.1084-5 Annex 4, Tables 1 and 3. The Table below also describes the harmonized channels where the digital technologies defined in the most recent version of Recommendation ITU-R M.1842 could be deployed. (WRC-15)

Channel designator	Notes	Transmitting frequencies (MHz)		Inter-ship	Port operations and ship movement		Public correspondence
		From ship stations	From coast stations		Single frequency	Two frequency	
60	<i>m)</i>	156.025	160.625		x	x	x
01	<i>m)</i>	156.050	160.650		x	x	x
61	<i>m)</i>	156.075	160.675		x	x	x
02	<i>m)</i>	156.100	160.700		x	x	x
62	<i>m)</i>	156.125	160.725		x	x	x
03	<i>m)</i>	156.150	160.750		x	x	x
63	<i>m)</i>	156.175	160.775		x	x	x
04	<i>m)</i>	156.200	160.800		x	x	x
64	<i>m)</i>	156.225	160.825		x	x	x
05	<i>m)</i>	156.250	160.850		x	x	x
65	<i>m)</i>	156.275	160.875		x	x	x
06	<i>f)</i>	156.300		x			
2006	<i>r)</i>	160.900	160.900				
66	<i>m)</i>	156.325	160.925		x	x	x
07	<i>m)</i>	156.350	160.950		x	x	x
67	<i>h)</i>	156.375	156.375	x	x		
08		156.400		x			
68		156.425	156.425		x		
09	<i>i)</i>	156.450	156.450	x	x		
69		156.475	156.475	x	x		
10	<i>h), q)</i>	156.500	156.500	x	x		
70	<i>f), j)</i>	156.525	156.525	Digital selective calling for distress, safety and calling			
11	<i>q)</i>	156.550	156.550		x		
71		156.575	156.575		x		
12		156.600	156.600		x		
72	<i>i)</i>	156.625		x			
13	<i>k)</i>	156.650	156.650	x	x		
73	<i>h), i)</i>	156.675	156.675	x	x		
14		156.700	156.700		x		
74		156.725	156.725		x		



Channel designator	Notes	Transmitting frequencies (MHz)		Inter-ship	Port operations and ship movement		Public correspondence
		From ship stations	From coast stations		Single frequency	Two frequency	
15	<i>g)</i>	156.750	156.750	x	x		
75	<i>n), s)</i>	156.775	156.775		x		
16	<i>f)</i>	156.800	156.800	DISTRESS, SAFETY AND CALLING			
76	<i>n), s)</i>	156.825	156.825		x		
17	<i>g)</i>	156.850	156.850	x	x		
77		156.875		x			
18	<i>m)</i>	156.900	161.500		x	x	x
78	<i>m)</i>	156.925	161.525		x	x	x
1078		156.925	156.925		x		
2078	<i>mm)</i>		161.525		x		
19	<i>m)</i>	156.950	161.550		x	x	x
1019		156.950	156.950		x		
2019	<i>mm)</i>		161.550		x		
79	<i>m)</i>	156.975	161.575		x	x	x
1079		156.975	156.975		x		
2079	<i>mm)</i>		161.575		x		
20	<i>m)</i>	157.000	161.600		x	x	x
1020		157.000	157.000		x		
2020	<i>mm)</i>		161.600		x		
80	<i>y), wa)</i>	157.025	161.625		x	x	x
21	<i>y), wa)</i>	157.050	161.650		x	x	x
81	<i>y), wa)</i>	157.075	161.675		x	x	x
22	<i>y), wa)</i>	157.100	161.700		x	x	x
82	<i>x), y), wa)</i>	157.125	161.725		x	x	x
23	<i>x), y), wa)</i>	157.150	161.750		x	x	x
83	<i>x), y), wa)</i>	157.175	161.775		x	x	x
24	<i>w), x)</i>	157.200	161.800		x	x	x
1024	<i>w)</i>	157.200	157.200	x (digital only)	x (digital only)		
2024	<i>w)</i>	161.800	161.800	x (digital only)	x (digital only)		
84	<i>w), x)</i>	157.225	161.825		x	x	x
1084	<i>w)</i>	157.225	157.225	x (digital only)	x (digital only)		
2084	<i>w)</i>	161.825	161.825	x (digital only)	x (digital only)		
25	<i>w), x)</i>	157.250	161.850		x	x	x
1025	<i>w)</i>	157.250	157.250	x (digital only)	x (digital only)		
2025	<i>w)</i>	161.850	161.850	x (digital only)	x (digital only)		
85	<i>w), x)</i>	157.275	161.875		x	x	x

Channel designator	Notes	Transmitting frequencies (MHz)		Inter-ship	Port operations and ship movement		Public correspondence
		From ship stations	From coast stations		Single frequency	Two frequency	
1085	w)	157.275	157.275	x (digital only)	x (digital only)		
2085	w)	161.875	161.875	x (digital only)	x (digital only)		
26	w), x)	157.300	161.900		x	x	x
1026	w)	157.300					
2026	w)		161.900				
86	w), x)	157.325	161.925		x	x	x
1086	w)	157.325					
2086	w)		161.925				
1027	zz)	157.350	157.350		x		
ASM 1	z)	161.950	161.950				
87	zz)	157.375	157.375		x		
1028	zz)	157.400	157.400		x		
ASM 2	z)	162.000	162.000				
88	zz)	157.425	157.425		x		
AIS 1	f), l), p)	161.975	161.975				
AIS 2	f), l), p)	162.025	162.025				

#### Notes referring to the Table

##### General notes

- a) Administrations may designate frequencies in the inter-ship, port operations and ship movement services for use by light aircraft and helicopters to communicate with ships or participating coast stations in predominantly maritime support operations under the conditions specified in Nos. **51.69**, **51.73**, **51.74**, **51.75**, **51.76**, **51.77** and **51.78**. However, the use of the channels which are shared with public correspondence shall be subject to prior agreement between interested and affected administrations.
- b) The channels of the present Appendix, with the exception of channels 06, 13, 15, 16, 17, 70, 75 and 76, may also be used for high-speed data and facsimile transmissions, subject to special arrangement between interested and affected administrations.
- c) The channels of the present Appendix, with the exception of channels 06, 13, 15, 16, 17, 70, 75 and 76, may be used for direct-printing telegraphy and data transmission, subject to special arrangement between interested and affected administrations. (WRC-12)
- d) The frequencies in this table may also be used for radiocommunications on inland waterways in accordance with the conditions specified in No. **5.226**.
- e) Administrations may apply 12.5 kHz channel interleaving on a non-interference basis to 25 kHz channels, in accordance with the most recent version of Recommendation ITU-R M.1084, provided:
  - it shall not affect the 25 kHz channels of the present Appendix maritime mobile distress and safety, automatic identification system (AIS), and data exchange frequencies, especially the channels 06, 13, 15, 16, 17, 70, AIS 1 and AIS 2, nor the technical characteristics set forth in Recommendation ITU-R M.489-2 for those channels;
  - implementation of 12.5 kHz channel interleaving and consequential national requirements shall be subject to coordination with affected administrations. (WRC-12)

## AP18-4

### *Specific notes*

- f)* The frequencies 156.300 MHz (channel 06), 156.525 MHz (channel 70), 156.800 MHz (channel 16), 161.975 MHz (AIS 1) and 162.025 MHz (AIS 2) may also be used by aircraft stations for the purpose of search and rescue operations and other safety-related communication. The frequencies 156.525 MHz (channel 70), 161.975 MHz (AIS 1) and 162.025 MHz (AIS 2) may also be used by autonomous maritime radio devices Group A that enhance the safety of navigation, using digital selective calling and/or AIS technology. Such use should be in accordance with the most recent version of Recommendation ITU-R M.2135. (WRC-19)
- g)* Channels 15 and 17 may also be used for on-board communications provided the effective radiated power does not exceed 1 W, and subject to the national regulations of the administration concerned when these channels are used in its territorial waters.
- h)* Within the European Maritime Area and in Canada, these frequencies (channels 10, 67, 73) may also be used, if so required, by the individual administrations concerned, for communication between ship stations, aircraft stations and participating land stations engaged in coordinated search and rescue and anti-pollution operations in local areas, under the conditions specified in Nos. **51.69**, **51.73**, **51.74**, **51.75**, **51.76**, **51.77** and **51.78**.
- i)* The preferred first three frequencies for the purpose indicated in Note *a)* are 156.450 MHz (channel 09), 156.625 MHz (channel 72) and 156.675 MHz (channel 73).
- j)* Channel 70 is to be used exclusively for digital selective calling for distress, safety and calling.
- k)* Channel 13 is designated for use on a worldwide basis as a navigation safety communication channel, primarily for intership navigation safety communications. It may also be used for the ship movement and port operations service subject to the national regulations of the administrations concerned.
- l)* These channels (AIS 1 and AIS 2) are used for an automatic identification system (AIS) capable of providing worldwide operation, unless other frequencies are designated on a regional basis for this purpose. Such use should be in accordance with the most recent version of Recommendation ITU-R M.1371. (WRC-07)
- m)* These channels may be operated as single frequency channels, subject to coordination with affected administrations. The following conditions apply for single frequency usage:
  - The lower frequency portion of these channels may be operated as single frequency channels by ship and coast stations.
  - Transmission using the upper frequency portion of these channels is limited to coast stations.
  - If permitted by administrations and specified by national regulations, the upper frequency portion of these channels may be used by ship stations for transmission. All precautions should be taken to avoid harmful interference to channels AIS 1, AIS 2, ASM 1 and ASM 2. (WRC-19)
- mm)* Transmission on these channels is limited to coast stations. If permitted by administrations and specified by national regulations, these channels may be used by ship stations for transmission. All precautions should be taken to avoid harmful interference to channels AIS 1, AIS 2, ASM 1 and ASM 2. (WRC-19)
- n)* With the exception of AIS, the use of these channels (75 and 76) should be restricted to navigation-related communications only and all precautions should be taken to avoid harmful interference to channel 16, by limiting the output power to 1 W. (WRC-12)
- o)* (SUP - WRC-12)
- p)* Additionally, AIS 1 and AIS 2 may be used by the mobile-satellite service (Earth-to-space) for the reception of AIS transmissions from ships. (WRC-07)
- q)* When using these channels (10 and 11), all precautions should be taken to avoid harmful interference to channel 70. (WRC-07)

- r) In the maritime mobile service, the frequency 160.9 MHz (channel 2006) is designated for autonomous maritime radio devices Group B that do not enhance the safety of navigation, using AIS technology, in accordance with the most recent version of Recommendation ITU-R M.2135. Autonomous maritime radio devices Group B are limited to a transmitter e.i.r.p. of 100 mW and an antenna height not exceeding 1 m above the surface of the sea.

In the maritime mobile service, this frequency may also be used for experimental use for future applications or systems (e.g. new AIS applications, man over board systems, etc.). If authorized by administrations for experimental use, the operation shall not cause harmful interference to, or claim protection from, stations operating in the fixed and mobile services, including the use of autonomous maritime radio devices Group B. (WRC-19)

- s) Channels 75 and 76 are also allocated to the mobile-satellite service (Earth-to-space) for the reception of long-range AIS broadcast messages from ships (Message 27; see the most recent version of Recommendation ITU-R M.1371). (WRC-12)
- t) (SUP - WRC-15)
- u) (SUP - WRC-15)
- v) (SUP - WRC-15)
- w) The frequency bands 157.1875-157.3375 MHz and 161.7875-161.9375 MHz (corresponding to channels: 24, 84, 25, 85, 26, 86, 1024, 1084, 1025, 1085, 1026, 1086, 2024, 2084, 2025, 2085, 2026 and 2086) are identified for the utilization of the VHF Data Exchange System (VDES). The VDES terrestrial and satellite components are described in the most recent version of Recommendation ITU-R M.2092. These channels shall not be used for feeder links. The channels may be merged using multiple 25 kHz contiguous channels to form channel bandwidths of 50, 100 or 150 kHz. The channel usage is shown below:
- The channels 1024, 1084, 1025 and 1085 are identified for ship-to-shore, shore-to-ship and ship-to-ship communications, but ship-to-satellite and satellite-to-ship communications may be possible without imposing constraints on ship-to-shore, shore-to-ship and ship-to-ship communications.
  - The channels 2024, 2084, 2025 and 2085 are identified for shore-to-ship and ship-to-ship communications, but ship-to-satellite and satellite-to-ship communications may be possible without imposing constraints on shore-to-ship and ship-to-ship communications.
  - The channels 1026, 1086, 2026 and 2086 are identified for ship-to-satellite and satellite-to-ship communications and are not used by the terrestrial component of VDES.
  - The channels 24, 84, 25 and 85 are identified for ship-to-shore and shore-to-ship communications.

The Earth-to-space component of the VDES shall not cause harmful interference to, nor claim protection from, nor restrict future development of, terrestrial systems operating in the same frequency bands.

Until 1 January 2030, the channels 24, 84, 25, 85, 26 and 86 may also be used for analogue modulation described in the most recent version of Recommendation ITU-R M.1084 by an administration that wishes to do so, subject to not causing harmful interference to, or claiming protection from other stations in the maritime mobile service using digitally modulated emissions and subject to coordination with affected administrations. (WRC-19)

- wa) In Regions 1 and 3:

The frequency bands 157.0125-157.1125 MHz and 161.6125-161.7125 MHz (corresponding to channels: 80, 21, 81 and 22) are identified for utilization of the digital systems described in the most recent version of Recommendation ITU-R M.1842 using multiple 25 kHz contiguous channels.

The frequency bands 157.1375-157.1875 MHz and 161.7375-161.7875 MHz (corresponding to channels: 23 and 83) are identified for utilization of the digital systems described in the most recent version of Recommendation ITU-R M.1842 using two 25 kHz contiguous channels. The frequencies 157.125 MHz and 161.725 MHz (corresponding to channel: 82) are identified for the utilization of the digital systems described in the most recent version of Recommendation ITU-R M.1842.

## AP18-6

The frequency bands 157.0125-157.1875 MHz and 161.6125-161.7875 MHz (corresponding to channels: 80, 21, 81, 22, 82, 23 and 83) can also be used for analogue modulation described in the most recent version of Recommendation ITU-R M.1084 by an administration that wishes to do so, subject to not claiming protection from other stations in the maritime mobile service using digitally modulated emissions and subject to coordination with affected administrations. (WRC-19)

- x) In Angola, Botswana, Eswatini, Lesotho, Madagascar, Malawi, Mauritius, Mozambique, Namibia, Democratic Republic of the Congo, Seychelles, South Africa, Tanzania, Zambia and Zimbabwe, the frequency bands 157.1125-157.3375 and 161.7125-161.9375 MHz (corresponding to channels: 82, 23, 83, 24, 84, 25, 85, 26 and 86) are designated for digitally modulated emissions.

In China, the frequency bands 157.1375-157.3375 and 161.7375-161.9375 MHz (corresponding to channels: 23, 83, 24, 84, 25, 85, 26 and 86) are designated for digitally modulated emissions. (WRC-19)

- y) These channels may be operated as single or duplex frequency channels, subject to coordination with affected administrations. (WRC-12)
- z) Channels ASM 1 and ASM 2 are used for application specific messages (ASM) as described in the most recent version of Recommendation ITU-R M.2092. (WRC-19)
- zz) Channels 1027, 1028, 87 and 88 are used as single-frequency analogue channels for port operation and ship movement. (WRC-19)

## APPENDIX 25 (REV.WRC-03)\*

**Provisions and associated frequency allotment Plan for coast radiotelephone stations operating in the exclusive maritime mobile bands between 4 000 kHz and 27 500 kHz**

The provisions of this Appendix shall apply to the maritime mobile radiotelephone bands reserved for duplex operation (two-frequency channels) between 4 000 kHz and 27 500 kHz (see Appendix 17). Section I contains the procedure for bringing up to date the frequency allotment Plan for coast stations. The allotment Plan is contained in Section II of this Appendix.

**25/1 Section I – Procedure for bringing up to date the frequency allotment plan**

**25/1.1** 1 Before notifying to the Radiocommunication Bureau or bringing into use at any coast radiotelephone station a frequency assignment not covered by an allotment in the Frequency Allotment Plan contained in Section II of this Appendix, an administration which

**25/1.1.1** intends to establish a coast radiotelephone station and has no allotment in the Plan, *or*

**25/1.1.2** intends to expand its coast radiotelephone service and requires an additional allotment,

shall send the information listed in Appendix 4 to the Bureau not earlier than two years in the case of No. 25/1.1.1, or not earlier than six months in the case of No. 25/1.1.2, before the projected date of bringing into service of the planned coast radiotelephone service but in any case not later than three months before that date.

**25/1.2** The Bureau shall publish the information sent under No. 25/1.1 in a Special Section of the BR International Frequency Information Circular (BR IFIC) together with such apparent incompatibilities between the proposed allotment which is the subject of the publication and any other existing or proposed allotments which the Bureau can identify. The Bureau shall also indicate any information of a technical nature and make such suggestions as it may be able to offer with a view to avoiding these incompatibilities.

**25/1.3** If it is requested by any administration, particularly by an administration of a country in need of special assistance, and if the circumstances appear to warrant, the Bureau, using such means at its disposal as are appropriate in the circumstances, shall render the following assistance:

**25/1.3.1** indication of a suitable channel or channels for the service projected by the administration before that administration submits the information for publication;

**25/1.3.2** carry out the procedure for which provision is made in No. 25/1.4;

---

\* This revision contains an up-to-date version of Appendix, reflecting all amendments to Section II and the Table of allotments resulting from the application of the procedure of Section I, up to and including 10 May 2016, as well as those amendments, which resulted from geopolitical changes that occurred up to and including that date.

## AP25-2

25/1.3.3 any other assistance of a technical nature for completion of the procedure in this Section.

25/1.4 2 At the same time as sending the information listed in Appendix 4 to the Bureau for publication, an administration shall seek the agreement of the administrations having an allotment in the same channel as the proposed allotment. A copy of the relevant correspondence shall be sent to the Bureau.

25/1.5 Any administration which, upon examining the information published by the Bureau, considers that its existing services or services planned within the time-limits mentioned in No. 25/1.1 would be affected shall have the right to be brought into the procedure undertaken pursuant to No. 25/1.4.

25/1.6 3 An administration which receives a request under No. 25/1.4 shall acknowledge receipt thereof immediately by telegram. If no acknowledgement is received within thirty days after the date of the BR IFIC containing the information published under No. 25/1.2, the administration seeking agreement shall dispatch a telegram requesting acknowledgement, to which the receiving administration shall reply within a further period of fifteen days.

25/1.7 Upon receipt of the request under No. 25/1.4, an administration shall, having regard to the proposed date of bringing into use of the assignment(s) corresponding to the allotment for which agreement was requested, promptly examine the matter with regard to harmful interference which would be caused to the services rendered by its coast station(s):

25/1.7.1 using a frequency assignment corresponding to an allotment appearing in the Plan; *or*

25/1.7.2 to be brought into service in conformity with an allotment appearing in the Plan within the time-limit prescribed in No. 25/1.25; *or*

25/1.7.3 to be brought into service within the time-limit prescribed in No. 25/1.25, in conformity with a proposed allotment for which the information has been submitted to the Bureau under No. 25/1.1 for publication under No. 25/1.2.

25/1.8 Any administration which receives a request under No. 25/1.4 and which considers that the proposed use of a channel will not cause harmful interference to the services rendered by its coast stations as outlined in No. 25/1.7 shall, as soon as possible and not later than two months from the date of the relevant BR IFIC, notify its agreement to the administration seeking agreement.

25/1.9 Any administration which receives a request under No. 25/1.4 and which considers that the proposed use of a channel may cause harmful interference to the services rendered by its coast stations as outlined in No. 25/1.7 shall inform the administration concerned of the reasons for its disagreement as soon as possible and not later than two months from the date of the relevant BR IFIC and shall furnish any information and suggestions with a view to reaching a satisfactory solution of the problem. The administration seeking agreement shall try, as far as possible, to adjust its requirements according to the comments received.

25/1.10 In a case where the administration seeking agreement has no allotment in the band concerned, the administration(s) with which agreement is sought shall, in consultation with the requesting administration, explore all means of meeting the requirement of the requesting administration.

**25/1.11 4** An administration seeking agreement may request the Bureau to endeavour to obtain such agreement in those cases where:

**25/1.11.1** an administration to which a request has been sent under No. **25/1.4** fails to acknowledge receipt of the request within forty-five days from the date of the BR IFIC containing the pertinent information;

**25/1.11.2** an administration has acknowledged receipt under No. **25/1.6** but fails to give a decision within two months from the date of the BR IFIC containing the pertinent information;

**25/1.11.3** there is disagreement between the administration seeking agreement and an administration with which agreement is sought as to the sharing possibilities;

**25/1.11.4** it is not possible to reach agreement for any other reason.

**25/1.12** Either the administration seeking agreement or an administration with which agreement is sought, or the Bureau, may request additional information which it may require in studying any problem relating to this agreement.

**25/1.13** Where the Bureau receives a request under No. **25/1.11.1**, it shall forthwith send a telegram to the administration concerned requesting immediate acknowledgement.

**25/1.14** Where the Bureau receives an acknowledgement following its action under No. **25/1.13**, or where the Bureau receives a request under No. **25/1.11.2**, it shall forthwith send a telegram to the administration concerned requesting an early decision in the matter.

**25/1.15** Where the Bureau receives a request under No. **25/1.11.4**, it shall endeavour to obtain agreement to which reference is made in No. **25/1.4**. Where the Bureau receives from an administration no acknowledgement to the request it made under the terms of No. **25/1.4** for agreement within the period specified in No. **25/1.6**, it shall act, in so far as this administration is concerned, in accordance with No. **25/1.13**.

**25/1.16** Where an administration fails to reply within fifteen days of the Bureau's telegram requesting an acknowledgement sent under No. **25/1.13**, or fails to give a decision in the matter within thirty days of dispatch of the Bureau's telegram of request under No. **25/1.14**, it shall be deemed that the administration with which agreement was sought has undertaken, once the projected allotment is included in the Plan:

**25/1.16.1** that no complaint will be made in respect of any harmful interference which may be caused to the services rendered by its coast radiotelephone stations by the use of assignments in accordance with the allotment for which agreement was requested; and

**25/1.16.2** that its existing or projected coast radiotelephone stations will not cause harmful interference to the use of assignments in conformity with the allotment for which agreement was requested.

**25/1.17** The Bureau shall examine the proposed allotment with respect to the probability of harmful interference which it may receive from an allotment in the Plan of the administration which failed to reply or which indicated disagreement without supplying the reasons; if the finding is favourable and where the application of the present procedure with respect to the other administrations concerned permits, the Bureau shall enter the proposed allotment in the Plan.



## AP25-4

**25/1.18** In the event of an unfavourable finding, the Bureau shall inform the administration concerned of the result of the examination; if the administration insists, and where the application of the present procedure with respect to the other administrations concerned permits, the Bureau shall enter the proposed allotment in the Plan.

**25/1.19** Where the Bureau receives a request under No. **25/1.11.3**, it shall assess the sharing possibilities and it shall inform the administrations concerned of the results obtained.

**25/1.20** In the case of continuing disagreement, the Bureau shall examine the proposed allotment from the point of view of harmful interference which may be caused to the services rendered by the stations of the administration having declared its disagreement. In the case where the Bureau's finding is favourable and where the application of the present procedure with respect to the other administrations concerned permits, it shall enter the proposed allotment in the Plan.

**25/1.21** If, after the examination under No. **25/1.20**, the Bureau reaches an unfavourable finding, it shall then examine the proposed allotment from the point of view of harmful interference which may be caused to the services on all the various channels in the band. Should the Bureau reach an unfavourable finding in each case, it shall determine the channel which is the least affected and, if so requested by the administration seeking agreement, it shall enter the proposed allotment in this channel in the Plan.

**25/1.22** 5 An administration seeking agreement for a proposed allotment shall inform the Bureau of the results of its consultations with the administrations concerned. When the Bureau finds that the procedure prescribed in this Section has been applied with respect to each administration concerned, the Bureau shall publish its finding in a Special Section of the BR IFIC and, as the case may be, bring the Plan up to date.

**25/1.23** 6 Notwithstanding the above provisions and if the circumstances justify, an administration may, in exceptional circumstances, notify to the Bureau for provisional entry in the Master International Frequency Register an assignment which is not covered by an allotment in the Plan. That administration shall, however, begin forthwith the procedure prescribed in this Section.

**25/1.24** 7 When, within twelve months from the date of the inclusion of the allotment in the Plan, the Bureau does not receive a notice of a first frequency assignment corresponding to this allotment, or where the first notified frequency assignment has not been brought into use within the time-limits prescribed in these Regulations, before proceeding with the deletion of the allotment from the Plan, it shall consult with the administration concerned on the appropriateness of such a deletion and of publishing this information in connection with bringing the Plan up to date. However, in the case where the Bureau, in the light of a request from the administration concerned, finds that exceptional circumstances warrant an extension of this period, the extension shall in no case exceed six months, except in the case of an administration which has no coast station in service in which case the period may be extended to eighteen months.

**25/1.25** 8 Any administration in whose name an allotment is shown in the Plan, and which has a need to replace this allotment by another allotment in the same frequency band with a view to improving its service, shall apply the procedure described in this Section. When that administration arrives at a positive result in applying this procedure, the Bureau, at its request, shall replace the existing allotment in the Plan by the proposed allotment.

**25/1.26** 9 The Bureau shall maintain an up-to-date master copy of the Plan resulting from the application of this procedure. It shall prepare in a suitable form, for publication by the Secretary-General, the whole or part of the revised version of the Plan as and when the circumstances justify and in any case once annually.

**25/2 Section II – Allotment Plan for coast radiotelephone stations operating in the exclusive maritime mobile bands between 4 000 kHz and 27 500 kHz<sup>1</sup>**

**25/2.1** The frequencies in Column 1 are assigned frequencies (see No. 1.148) as listed in Section I of Part B of Appendix 17. Each frequency is followed, in parentheses, by the carrier frequency and the channel number (see Section I of Part B of Appendix 17).

**25/2.2** The coast radiotelephone stations operating in the bands allocated exclusively to the maritime mobile service between 4 000 kHz and 27 500 kHz must use the minimum power required to cover their service area. They may in no case use a peak envelope power above 10 kW per channel (see No. 52.219).

**25/2.3** The Plan contained in this Appendix will be updated in accordance with the procedure defined in Section I of this Appendix.

**25/2.4** (WRC-03)

<b>Column 1</b>	<b>Column 2</b>	<b>Column 3</b>
Assigned frequency (carrier frequency) (channel number)	Allotment area <sup>2</sup>	Observations <sup>3</sup>

---

<sup>1</sup> The Plan includes additions, modifications and deletions of allotments in the channels of the Frequency Allotment Plan adopted by the WMARC-74, resulting from the application of the relevant plan updating procedures up to and including 10 May 2016, as well as those amendments, which resulted from geopolitical changes that occurred up to and including that date.

<sup>2</sup> The meaning of the symbols is given in Tables “Areas” and “Standard Defined Areas” of the Preface to the BR IFIC.

<sup>3</sup> ADD This allotment has been entered in the Plan as a result of the application of the procedure of Section I of this Appendix.



<b>1</b>	<b>2</b>	<b>3</b>
(407)	<< << RUS NW SNG TUR USA E USA W	
<b>4 379.4</b> <b>(4 378)</b>  (408)	ALS ARG B BEL BES CAN E CAN W CUW CHN GUM HRV HWA I INS IRN J MDA MLD MOZ NZL POL SMA SUI SXM USA E USA W	ADD               ADD ADD   ADD
<b>4 382.4</b> <b>(4 381)</b>  (409)	ARS B CHN CUB DNK GHA I IND W NOR PNG QAT S THA TUR USA CL USA E USA SO USA W	ADD        ADD
<b>4 385.4</b> <b>(4 384)</b>  (410)	ALG ARG SO CAN W CHN CNR D2 G GRC GUM >> >>	

<b>1</b>	<b>2</b>	<b>3</b>
(410)	<< << HNG HOL IRN ISR MLT MTN NZL ROU SEY USA E	
<b>4 388.4</b> <b>(4 387)</b>  (411)	AMS ARG NO BEL E EQA FLK HKG I INS IRN J KIR RUS NW TUR UKR USA CL USA E USA W	ADD            ADD ADD  ADD
<b>4 391.4</b> <b>(4 390)</b>  (412)	AUS D1 EST GEO I IND W IRQ J LTU LVA RUS EO RUS NW RUS SW RUS W UKR USA E USA SO USA W YEM	
<b>4 394.4</b> <b>(4 393)</b>  (413)	AGL ALG ALS ARG AZR BHR CAN E CAN W CPV D1 >> >>	

<b>1</b>	<b>2</b>	<b>3</b>
(413)	<< << FIN GNB GRC GUM HWA J MCO MDR PNR POR PTR RUS EO TLS UKR USA CL USA E USA SO USA W	
<b>4 397.4</b> <b>(4 396)</b>  (414)	ALS CYP D1 E FIN INS ISL J KEN PTR RUS EO RUS SW RUS W SHN USA E USA SO	
<b>4 400.4</b> <b>(4 399)</b>  (415)	ALS ARG AUS CHN DNK EST F GRC GUM HWA IRN LTU LVA MDG MLA PNR PTR ROU RUS NW RUS SW RUS W USA E USA SO USA W	

1	2	3
4 403.4 (4 402)  (416)	ALS ARG CL B EST F G GRC HNG INS IRN ISL J LTU LVA MAU OCE RUS SW USA CL USA E USA W	
4 406.4 (4 405)  (417)	ARG AUS BEL CZE FIN G HKG HRV IND W J MLA MNE MRC PNG RUS EO SVK TUR TZA USA CL USA E USA SO USA W YEM	ADD
4 409.4 (4 408)  (418)	ARG AZE B BUL CAN E CAN W CUB DJI DNK E EGY HWA I INS ISR >>>	ADD          ADD

1	2	3
(418)	<<<< J KAZ MTN ROU RUS AS S TKM USA CL	
4 412.4 (4 411)  (419)	AUS B CHL CHN CZE D2 F GUM HOL HRV HWA ISL J KOR LBY PTR RUS NW SVN TZA USA SO USA W	ADD
4 415.4 (4 414)  (420)	ALS AZE BUL CME DNK GUM HWA I IND E IRN J JOR KAZ MLA MRC PNR PTR RUS AN RUS AS S TKM TUR USA E USA W	
4 421.4 (4 420)  (422)	ALS BEL CAN W CHN >>>	

1	2	3
(422)	<<<< CNR CUB EST FIN G GRC HNG INS IRQ J LBY LTU LVA MRC RUS NW RUS SW RUS W SUI USA E USA W	ADD
4 424.4 (4 423)  (423)	ALS B CHN D1 I INS ISR J MLT PNG PNR POL QAT USA CL USA E USA SO USA W	ADD       ADD
4 427.4 (4 426)  (424)	ALG ALS ARG AUS E AUS W CHN DNK GRC GUM HWA MRC PNR PTR S SUI THA USA CL USA E USA SO USA W	ADD          ADD



1	2	3
(602)	<<<< CAN E CAN W EQA EST FJI GEO GHA GUM HOL HRV HWA I INS IRN KAZ KOR LTU LVA MCO MDG POL POR PTR RUS AN RUS AS RUS EO RUS NW RUS SW RUS W SNG TKM TUN TUR USA CL USA E USA SO USA W	ADD  ADD  ADD
<b>6 508.4</b> <b>(6 507)</b>  (603)	ALB ALG ALS ARG ARS AUS CAN NO CAN W CYP DNK E GRC GUM HNG HWA IND E INS IRN IRQ ISL ISR >>>>	ADD

1	2	3
(603)	<<<< J LBY MLT MTN PTR ROU RUS EO RUS NW S SMO UKR USA CL USA E USA SO USA W VTN	ADD          ADD
<b>6 511.4</b> <b>(6 510)</b>  (604)	ALS AUS B BES BUL CAN W CHL CHN CME CUW E GUM HKG HRV HWA I INS IRN ISR MDG MTN PNG POL PTR RUS EO RUS NW SXM TUN TUR TUV USA CL USA E USA SO USA W VTN	ADD ADD ADD       ADD          ADD       ADD
<b>6 514.4</b> <b>(6 513)</b>  (605)	ALG ALS B BUL CAN E CAN W CNR COG >>>>	ADD

1	2	3
(605)	<<<< DNK EGY F GUM HNG HOL HRV HWA IND W INS IRN IRQ J KOR LBY MDG NZL PTR RUS EO S SVN UKR URG USA CL USA E USA SO USA W	ADD             ADD          ADD
<b>6 520.4</b> <b>(6 519)</b>  (607)	ARG AUS CHN CLM CUB DGA F GRC HKG J MDA MDG OMA RUS AN RUS EO RUS NW UAE USA SO VTN	ADD
<b>6 523.4</b> <b>(6 522)</b>  (608)	ALS ARG CL ARG SO AUS B BLR BRU CHN DGA E EST G >>>>	ADD

1	2	3
(608)	<<<< GRC GUM HWA J KOR LVA MDW MOZ PTR RUS AS RUS AN RUS EO RUS NW RUS SW RUS W UKR USA E USA SO USA W	
<b>8 720.4</b> <b>(8 719)</b>  (801)	AFS ALS BHR CHL DNK E GUM HWA ISR J MLA PNR PTR ROU RUS AN S USA E USA SO USA W	
<b>8 723.4</b> <b>(8 722)</b>  (802)	AGL ALG ALS ARG AUS AZR CHN CLN CPV D2 FIN G GNB GRC HOL HWA IND E IRQ MDA >>>>	ADD

1	2	3
(802)	<<<< MDR MOZ POR USA E USA SO	
<b>8 726.4</b> <b>(8 725)</b>  (803)	AFS BEL BES CAN E CUB CUW E KOR LTU LVA PNG RUS EO RUS NW RUS SW S SEN SUI SXM TUR USA CL	ADD
<b>8 729.4</b> <b>(8 728)</b>  (804)	ARG E FIN GRC IRQ J JOR MCO POL QAT RUS AS RUS EO SNG USA E USA SO USA W	ADD ADD
<b>8 732.4</b> <b>(8 731)</b>  (805)	AFS ALB BEL E EQA FIN HOL IRN ISL ISR J LVA NCL PNG RUS EO RUS SW >>>>	ADD

1	2	3
(805)	<<<< USA E USA SO USA W	
<b>8 735.4</b> <b>(8 734)</b>  (806)	ALS ARG AUS BEL BHR E GRC GUM HOL HWA I J PNR POL PTR SMA UKR USA E USA W	ADD ADD
<b>8 738.4</b> <b>(8 737)</b>  (807)	AZE CAN W CHL COG CUB CYP CZE I ISL J MDG MTN NZL RUS AN RUS AS RUS SW RUS W SHN TKM USA CL	ADD
<b>8 741.4</b> <b>(8 740)</b>  (808)	AFS ALS ARG ARS DNK E GRC GUM HWA I J ROU S USA E USA W	ADD



1	2	3
8 744.4 (8 743)  (809)	ALG AUS W CHL CNR CUB CZE D2 FIN GRC ISL J MCO NOR SVK THA USA E USA W	
8 747.4 (8 746)  (810)	ARG BUL CAN E CHN E FJI HRV INS IRN J MOZ NOR POL TUR USA E USA SO USA W	
8 750.4 (8 749)  (811)	ARG ARS AUS BEN DNK F HKG HNG HRV J MNE NOR S TUR USA E USA SO USA W	ADD
8 753.4 (8 752)  (812)	ALS ARG SO BEL CAN NO CHN E GEO >> >>	

1	2	3
(812)	<<<< HWA I INS ISR J LTU LVA NZL POL RUS NW USA CL USA E USA SO USA W	ADD
8 756.4 (8 755)  (813)	AGL ALG ALS AUS AZR BEL CHL NO CHN CPV DNK GNB GRC GUM HNG HWA IND W MDR MOZ NOR PNR POR PTR USA CL USA E USA SO USA W VTN	ADD
8 759.4 (8 758)  (814)	ALS ARG AZE CAN W CUB EST GEO GRC HWA I INS J KIR LTU LVA RUS AN >> >>	ADD

1	2	3
(814)	<< << RUS AS RUS EO RUS SW RUS W USA CL USA E USA SO USA W	
8 762.4 (8 761)  (815)	AUS W BEL CHL CHN DI EST GRC IRQ J JOR MRC RUS NW RUS SW SNG USA E USA SO USA W	ADD
8 765.4 (8 764)  (816)	ALS ARG BRB CHN COG E G GRC GUM HWA INS LTU LVA PTR RUS NW RUS SW RUS W TUN USA E USA SO USA W	
8 768.4 (8 767)  (817)	ALS AUS CAN E CHL DI EGY F GUM HWA IRN PNR >> >>	ADD

1	2	3
(817)	<< << PTR ROU RUS EO RUS SW THA USA CL USA E USA SO USA W YEM	
<b>8 771.4</b> <b>(8 770)</b>  (818)	ALS ARG BUL CHN CME CYP DNK GUM HWA LBY MLA PNR PTR S SEY UKR USA E USA W	
<b>8 774.4</b> <b>(8 773)</b>  (819)	ALS AZE B CAN W EST G GEO GRC GUM HWA I INS J KAZ LVA PAQ PNR RUS AN RUS AS RUS NW RUS SW THA TKM USA CL USA E USA SO USA W YEM	ADD

1	2	3
<b>8 777.4</b> <b>(8 776)</b>  (820)	ALS ARG CYP D1 D2 GRC GUM HWA I IND E IRN J PNR PTR RUS NW SMO TZA USA E USA W	ADD
<b>8 783.4</b> <b>(8 782)</b>  (822)	AUS B CHN G HNG HRV IRN KEN MRC SUI UKR USA E USA SO USA W	ADD
<b>8 786.4</b> <b>(8 785)</b>  (823)	ARG CAN E DNK GRC I IND W IRQ J ROU RUS EO RUS NW S TLS TZA USA W	ADD ADD
<b>8 789.4</b> <b>(8 788)</b>  (824)	B CHN D1 GRC IRN MRC OMA POL RUS NW SNG SUI >> >>	

1	2	3
(824)	<< <<< TUN USA E USA SO USA W	
<b>8 792.4</b> <b>(8 791)</b>  (825)	ALG ALS AMS ARG BRB CAN CL CKH DNK F GHA HNG IND E IRN KAZ KGZ RUS EO S TKM UKR USA E USA SO USA W	ADD  ADD  ADD
<b>8 795.4</b> <b>(8 794)</b>  (826)	CAN W CAN NO CHN CLM CME D2 G GUM HOL I INS J QAT UKR USA CL USA E	ADD  ADD
<b>8 798.4</b> <b>(8 797)</b>  (827)	ALS ARG DJI DNK E GUM HRV HWA IRN ISR KOR MAC MNE NIU >> >>	

1	2	3
(827)	<<<< PNR PTR S SVN USA E USA W	
<b>8 801.4</b> <b>(8 800)</b>  (828)	ALB ALS B D1 F GUM HNG HWA INS J MAU MRC MTN NOR PNR PTR UKR USA E USA W	
<b>8 804.4</b> <b>(8 803)</b>  (829)	AUS BEL BRM CHN CYP DNK FIN GMB IRN LBY MLD NOR OCE PRG S UKR USA E USA SO USA W	ADD  ADD
<b>8 807.4</b> <b>(8 806)</b>  (830)	AZE B BUL CHN F HRV IND W INS IRN KAZ MCO PNG >> >>	ADD

1	2	3
(830)	<<<< POL PTR RUS AS RUS EO USA SO YEM VTN	ADD
<b>8 810.4</b> <b>(8 809)</b>  (831)	CHN COG D2 FLK G I IRN ISL J MDG MLA MRC PTR SUI TUR USA SO USA W	
<b>8 813.4</b> <b>(8 812)</b>  (832)	ALS B BUL CHN CLM GUM HKG HWA KOR MDG MLT PTR QAT RUS AN RUS EO TUR UAE URG USA E USA SO USA W VTN	
<b>8 708.4</b> <b>(8 707)</b>  (834)	AUS BHR CHL CHN CLM DGA GRC GUM HWA J KOR MDW >> >>	ADD

1	2	3
(834)	<<<< POR PTR RUS AS RUS NW RUS SW RUS W UKR USA E USA SO	
<b>8 711.4</b> <b>(8 710)</b>  (835)	ALS ARG CL ARG SO AZE BRU DGA E F GRC GUM HWA J KOR MDW MNE OMA PTR RUS AN RUS AS RUS EO RUS NW SUI THA TKM TUR UKR USA E USA SO USA W	ADD
<b>8 714.4</b> <b>(8 713)</b>  (836)	AUS AZE CHL CHN E I RUS AN RUS AS RUS EO RUS NW TKM UKR URG USA SO	
<b>8 717.4</b> <b>(8 716)</b>  (837)	ARG CL ARG SO AZE BLR CHN CUB >> >>	

1	2	3
(837)	<<<< G GRC J KAZ MDG RUS AN RUS AS RUS EO RUS NW RUS SW RUS W TKM UKR USA SO	
<b>13 078.4</b> <b>(13 077)</b>  (1201)	ARG CAN NO CHN CYP E G INS QAT RUS EO RUS NW RUS SW UKR USA E USA SO USA W	ADD
<b>13 081.4</b> <b>(13 080)</b>  (1202)	ARS CHL D2 FJI G GRC HNG J MRC RUS AN SUI TUN USA CL USA E USA SO USA W	
<b>13 084.4</b> <b>(13 083)</b>  (1203)	AGL ALS AUS E AZR CHN CLM CPV DNK GNB GRC HWA IRQ LBY >> >>	

1	2	3
(1203)	<<<< MDR MOZ POR RUS EO S TLS USA CL USA E USA SO USA W	
<b>13 087.4</b> <b>(13 086)</b>  (1204)	ALS D2 F GRC GUM HWA ISR J LVA MAC NOR PNR PTR RUS SW RUS W USA E USA SO USA W	
<b>13 090.4</b> <b>(13 089)</b>  (1205)	ALS ARG D1 E GEO GUM HWA I J LTU LVA MOZ NCL NOR PTR TLS UKR USA E USA SO USA W YEM	
<b>13 093.4</b> <b>(13 092)</b>  (1206)	ALB AUS W CHN D2 E FIN G >> >>	

1	2	3
(1206)	<<<< I IRN ISL J MDG MRC TUR USA E USA SO USA W	
<b>13 096.4</b> <b>(13 095)</b>  (1207)	AGL ALG AZR BEL BES CAN W CHN CPV CUW EQA GRC HOL IRN ISR J MDR MNE MOZ POR RUS NW SXM TLS	ADD
<b>13 099.4</b> <b>(13 098)</b>  (1208)	ARG CHN CYP D1 EST GRC HNG I ISL J LTU LVA RUS SW RUS W USA E USA SO	ADD
<b>13 102.4</b> <b>(13 101)</b>  (1209)	AFS ALS B BHR CAN W E EST >> >>	

1	2	3
(1209)	<<<< FIN I INS J NZL POL RUS NW RUS SW TUR USA E USA SO USA W	
<b>13 105.4</b> <b>(13 104)</b>  (1210)	CHL DJI DNK E GRC GUM IND W INS ROU RUS AN RUS EO S SUI URG USA E USA SO USA W	ADD
<b>13 108.4</b> <b>(13 107)</b>  (1211)	ALS B CHN CUB DNK E I IRQ J KAZ MLA NOR PAQ RUS AN RUS AS S TKM USA CL USA E USA SO USA W	
<b>13 111.4</b> <b>(13 110)</b>  (1212)	ALS D1 GRC HWA INS J MAU MDA >>>>	ADD

1	2	3
(1212)	<<<< PTR RUS AS RUS EO RUS SW RUS W USA E USA SO	ADD
<b>13 114.4</b> <b>(13 113)</b>  (1213)	ARG BEL BRB CAN E CHN CNR FIN GRC HOL I IND E IRN IRQ ISR KOR NOR RUS AN SMO USA W	ADD
<b>13 117.4</b> <b>(13 116)</b>  (1214)	ALS AUS B CAN W CUB DNK GRC GUM HNG IRN PTR RUS EO S USA CL USA E USA SO USA W	
<b>13 120.4</b> <b>(13 119)</b>  (1215)	ALG BEL BHR CME DNK E GRC HOL IND W ISL ISR J PNR PTR ROU >>>>	ADD

1	2	3
(1215)	<<<< S SEY USA SO USA W	
<b>13 123.4</b> <b>(13 122)</b>  (1216)	ALB ALS ARG CHN EGY FIN GUM HWA IRN MRC PNR POL PTR SNG TUR USA E USA SO USA W	
<b>13 126.4</b> <b>(13 125)</b>  (1217)	ALG AZE BUL CUB DNK GRC GUM IND E IRQ J KAZ NOR RUS AS RUS EO S SHN USA CL USA E USA SO USA W	
<b>13 129.4</b> <b>(13 128)</b>  (1218)	ALS BEL CHL CME CNR D1 GUM HWA I IRN J NIU NOR PNR PTR RUS SW >>>>	

1	2	3
(1218)	<<<< TUR USA E USA SO USA W	
<b>13 132.4</b> <b>(13 131)</b>  (1219)	ALS B BEL BUL DNK HOL J LTU LVA MRC RUS EO RUS NW RUS SW RUS W S SNG UKR USA E USA SO USA W	
<b>13 135.4</b> <b>(13 134)</b>  (1220)	ALS ARG D2 FJI GRC GUM HWA IRN ISL J JOR PNR POL PTR TUN USA E USA SO USA W	ADD      ADD
<b>13 141.4</b> <b>(13 140)</b>  (1222)	ALS ARG BEN CAN E CKH F HWA IND W IRN J NOR ROU RUS EO TUR USA W	ADD ADD          ADD

1	2	3
<b>13 144.4</b> <b>(13 143)</b>  (1223)	ARS B CZE DNK GRC GUM J MRC S SVK UKR USA E USA SO USA W	
<b>13 147.4</b> <b>(13 146)</b>  (1224)	AFS ALS CHL DI FIN G GHA GUM HRV HWA J MCO NZL PNR PTR USA E USA W	ADD
<b>13 150.4</b> <b>(13 149)</b>  (1225)	CHN E GRC IRN JOR MDG NOR PNG ROU RUS NW USA E USA SO	ADD
<b>13 153.4</b> <b>(13 152)</b>  (1226)	AUS CHL CZE DNK F IRN J MCO RUS NW S TUR USA E USA SO USA W	ADD ADD

1	2	3
<b>13 156.4</b> <b>(13 155)</b>  (1227)	ALS AUS E FIN GUM HRV HWA IND E PNR POL PTR RUS EO SUI TZA USA E USA W	ADD
<b>13 159.4</b> <b>(13 158)</b>  (1228)	B CHL CHN CUB EST G GEO HNG I LVA MLD NOR RUS SW RUS W UKR USA CL USA E USA W VTN	ADD ADD  ADD
<b>13 162.4</b> <b>(13 161)</b>  (1229)	ARG AUS AZE BUL CAN E F HRV J KAZ KGZ KOR LTU LVA POL QAT RUS AN RUS AS RUS NW RUS SW RUS W USA W	ADD

1	2	3
13 165.4 (13 164)  (1230)	ARG CYP FIN G HWA I J MTN SUI UKR USA E USA SO USA W	
13 168.4 (13 167)  (1231)	ALS AUS F GRC GUM HKG HWA IRN LBY NOR PNR POL PRG PTR USA E USA W VTN	ADD
13 171.4 (13 170)  (1232)	ALG ALS ARG AZE D2 G GRC GUM HWA J KAZ MTN PNR SMA TKM USA E USA W	ADD ADD
13 174.4 (13 173)  (1233)	AZE B CHN CLM E G GEO GRC J LVA MLT RUS AN >> >>	

1	2	3
(1233)	<< << RUS AS RUS EO RUS NW RUS SW RUS W TKM TUR UKR USA SO VTN	
13 177.4 (13 176)  (1234)	ALS AUS CHN CLM E HWA KOR MDG OMA RUS EO USA SO USA W	
13 180.4 (13 179)  (1235)	ARG CHN F G HOL J KOR LVA RUS AN RUS EO RUS NW RUS SW THA TUR UKR USA SO UZB	
13 183.4 (13 182)  (1236)	BRM CHN I RUS EO UAE UKR USA SO	ADD
13 186.4 (13 185)  (1237)	CHN F ISR J LVA PTR RUS AS RUS SW SUI TUR UAE UKR >> >>	

1	2	3
(1237)	<< << USA CL USA E USA SO VIR	
13 189.4 (13 188)  (1238)	ALS B BLR CHL CHN EST GUM HWA KOR MCO PAQ PTR RUS AN RUS AS RUS EO RUS NW RUS SW TKM TUR UKR USA E USA SO USA W	ADD
13 192.4 (13 191)  (1239)	ALS AZE B BRU BUL CAN E CHN E F GUM HWA J KAZ MDG MNE PTR QAT RUS AN RUS AS RUS EO RUS SW RUS W TKM TUR UKR USA E USA SO USA W	ADD
13 195.4 (13 194)  (1240)	ARG CL ARG SO AUS >> >>	

1	2	3
(1240)	<< << CHN DGA GRC GUM HKG HWA KGZ MDW POR PTR RUS AN RUS EO RUS NW RUS SW RUS W USA E USA SO USA W	
<b>13 198.4</b> <b>(13 197)</b>  (1241)	ALS CHN D2 DGA GUM HWA IND E IND W J MDW PTR UKR USA E USA W	
<b>17 243.4</b> <b>(17 242)</b>  (1601)	ALS ARG DNK HWA J LTU NOR RUS NW RUS SW RUS W S SEY TUN UKR USA E USA SO	
<b>17 246.4</b> <b>(17 245)</b>  (1602)	ARS AUS E CME G GRC MRC RUS AN RUS EO RUS SW >> >>	

1	2	3
(1602)	<< << USA E USA SO USA W	
<b>17 249.4</b> <b>(17 248)</b>  (1603)	ALS ARG NO CHN CYP DNK HNG I MLT NOR S USA E USA SO USA W	ADD
<b>17 252.4</b> <b>(17 251)</b>  (1604)	AUS BEN CAN E F GRC J NOR ROU	ADD
<b>17 255.4</b> <b>(17 254)</b>  (1605)	DNK F IND W IRN J OCE RUS SW S UKR USA E USA W	
<b>17 258.4</b> <b>(17 257)</b>  (1606)	B CUB FIN G I ISL J NZL PTR RUS SW TUR USA SO USA W	
<b>17 261.4</b> <b>(17 260)</b>  (1607)	ALS BES CAN E CUW GRC IND E IRN MCO NOR POL >> >>	

1	2	3
(1607)	<< << RUS EO RUS NW SXM USA E USA SO USA W	
<b>17 264.4</b> <b>(17 263)</b>  (1608)	AFS CAN W CHN CZE DNK EQA I MTN S SVK TUR	ADD
<b>17 267.4</b> <b>(17 266)</b>  (1609)	ARS BEL CKH E GRC IND E ISR J RUS NW USA E USA SO USA W	
<b>17 270.4</b> <b>(17 269)</b>  (1610)	AUS CHN DI EGY INS IRN MTN NOR RUS NW TUN UKR URG USA E USA SO USA W	
<b>17 273.4</b> <b>(17 272)</b>  (1611)	B FIN G HRV J LBY MLA SUI TUR USA E USA SO USA W	



1	2	3
17 276.4 (17 275)  (1612)	ALS AUS CUB GEO GUM HWA JOR MRC PTR RUS EO RUS NW RUS SW UKR USA E USA SO USA W	ADD
17 279.4 (17 278)  (1613)	ALS B BEL E GRC GUM HWA IRN ISR NOR PNR PTR ROU RUS EO SNG USA E USA SO USA W	
17 282.4 (17 281)  (1614)	CAN W CHN DNK FIN I MLD NIU RUS AN S	ADD
17 285.4 (17 284)  (1615)	AGL AZR CPV FIN G GNB IRN ISL MDR MOZ POR RUS EO SUI TLS	

1	2	3
17 288.4 (17 287)  (1616)	ALS D1 HWA I IRN J MRC RUS NW TUR USA E USA SO USA W	
17 291.4 (17 290)  (1617)	B CNR DNK F GRC HNG IRN ISR RUS EO S	
17 294.4 (17 293)  (1618)	ARG BHR DNK G HRV IND W J MRC S TUR	
17 297.4 (17 296)  (1619)	ALS D2 F GRC GUM HWA MAU NOR PNR PTR RUS EO USA E USA W	
17 300.4 (17 299)  (1620)	J LBY LTU LVA NOR RUS SW RUS W TUR UKR USA CL USA E	

1	2	3
17 306.4 (17 305)  (1622)	ALS AUS DNK F GHA GRC HWA J PNR ROU S SUI	ADD  ADD ADD ADD ADD
17 309.4 (17 308)  (1623)	ALS CHN E FIN G GUM HOL HWA PNR PRG PTR UKR USA E USA SO USA W	
17 312.4 (17 311)  (1624)	D1 E I J LTU LVA RUS SW RUS W SMO USA E USA SO USA W	
17 315.4 (17 314)  (1625)	ALS BEL GRC GUM HWA IRN ISL J POL PTR USA E USA SO USA W	
17 318.4 (17 317)  (1626)	CAN W CUB GRC HOL IRQ J >> >>	

1	2	3
(1626)	<< << QAT RUS AN RUS EO RUS NW USA E	ADD
<b>17 321.4</b> <b>(17 320)</b>  (1627)	ALS BEL E EST GRC HNG HRV J LTU LVA NOR RUS SW RUS W	ADD
<b>17 324.4</b> <b>(17 323)</b>  (1628)	CUB EQA F GRC IRQ ISR MCO ROU RUS EO RUS NW	ADD  ADD
<b>17 327.4</b> <b>(17 326)</b>  (1629)	ALG AUS BRM CAN E D2 GRC IRN J NOR SEN	ADD
<b>17 330.4</b> <b>(17 329)</b>  (1630)	ALS BEL E GEO GUM HWA IND W ISL J LTU LVA PNR PTR RUS SW USA E USA SO USA W	
<b>17 333.4</b> <b>(17 332)</b>  (1631)	ALG BUL CHL >> >>	

1	2	3
(1631)	<< << CHN GRC IRQ POL SUI USA E	
<b>17 336.4</b> <b>(17 335)</b>  (1632)	ALS ARG AZR CYP G HNG J MDG MDR POR USA E USA SO USA W	
<b>17 339.4</b> <b>(17 338)</b>  (1633)	AFS ALS AZE B CHN D2 F GRC GUM HWA KAZ KGZ PNR POL PTR RUS AS TKM USA E USA W	
<b>17 342.4</b> <b>17 341</b>  (1634)	CAN NO CHN D1 E GRC J KOR ROU	
<b>17 345.4</b> <b>(17 344)</b>  (1635)	AGL AUS AZR BUL CPV DNK GNB I J MAC MDR MOZ >> >>	ADD

1	2	3
(1635)	<< << PNR POR S TLS	ADD
<b>17 348.4</b> <b>(17 347)</b>  (1636)	ALG ALS FIN GRC GUM HOL HWA IND E J PNR PTR USA E USA W	
<b>17 351.4</b> <b>(17 350)</b>  (1637)	AZE CHN E G HKG KAZ KOR MDG NZL RUS AS	
<b>17 354.4</b> <b>(17 353)</b>  (1638)	ALS BUL D2 FIN GUM HWA MNE MRC POL SMA USA E USA W	ADD  ADD
<b>17 357.4</b> <b>(17 356)</b>  (1639)	ALB ALS CHN D1 E GUM HOL HWA PNR PTR USA E USA W	
<b>17 360.4</b> <b>(17 359)</b>  (1640)	BRB CHL D2 EST G GRC >> >>	

1	2	3
(1640)	<<<< J LVA PNR	ADD
<b>17 363.4</b> <b>(17 362)</b>  (1641)	ALG DNK IRQ J S SNG UKR USA E USA SO USA W	
<b>17 366.4</b> <b>(17 365)</b>  (1642)	ALS AUS CLM F HWA J PTR RUS EO UAE USA CL USA E USA SO USA W VIR	
<b>17 369.4</b> <b>(17 368)</b>  (1643)	AZE CHN CLM F KAZ QAT RUS AN RUS EO RUS NW TKM UKR USA SO	
<b>17 372.4</b> <b>(17 371)</b>  (1644)	ALS B HWA I MDA RUS EO RUS NW UAE USA CL USA E USA SO USA W	ADD
<b>(17 375.4)</b> <b>(17 374)</b>  (1645)	ARG CHN ISR KGZ KOR LVA OMA >>>	

1	2	3
(1645)	<<<< RUS AN RUS EO RUS NW RUS SW RUS W TUR UKR USA SO UZB	
<b>17 378.4</b> <b>(17 377)</b>  (1646)	CHN I RUS EO RUS SW RUS W USA W VTN	ADD
<b>17 381.4</b> <b>(17 380)</b>  (1647)	ALS CAN E CHN EST HWA KOR LTU RUS AS RUS EO RUS NW TUR UKR USA CL USA E USA SO USA W	
<b>17 384.4</b> <b>(17 383)</b>  (1648)	ALS BLR CHN HWA KOR PTR RUS AN RUS AS RUS EO RUS NW RUS SW UKR USA CL USA W VIR	
<b>17 387.4</b> <b>(17 386)</b>  (1649)	ALS B BUL GUM HWA J MDG PTR RUS AN USA E USA SO USA W	

1	2	3
<b>17 390.4</b> <b>(17 389)</b>  (1650)	ALS ARG CL ARG SO AZE CHN E GRC HKG HWA J PTR RUS AN RUS NW RUS SW UKR USA E USA SO USA W	
<b>17 393.4</b> <b>(17 392)</b>  (1651)	ALS BLR CHN DGA E GUM HWA J MDW PTR RUS AN RUS EO RUS SW UKR USA E USA SO USA W	
<b>17 396.4</b> <b>(17 395)</b>  (1652)	CHN GUM HOL J MDG MDW MNE PTR RUS AN RUS EO RUS NW RUS SW TKM UKR USA E USA SO	
<b>17 399.4</b> <b>(17 398)</b>  (1653)	B CHN E PTR RUS AS RUS EO RUS NW RUS SW >>>	

1	2	3
(1653)	<< << RUS W UKR USA E USA SO USA W VTN	
<b>17 402.4</b> <b>(17 401)</b>  (1654)	CHN G HWA J PTR RUS SW UKR USA E USA SO USA W	
<b>17 405.4</b> <b>(17 404)</b>  (1655)	ALS CHL CHN DGA E G GRC GUM HWA KGZ MDW PTR RUS AN RUS NW RUS SW TUR UKR USA E USA SO USA W	
<b>17 408.4</b> <b>(17 407)</b>  (1656)	AUS CHN GUM HWA LVA MDW PTR RUS AN RUS NW RUS SW RUS W SUI UKR USA E USA SO USA W	
<b>19 756.4</b> <b>(19 755)</b>  (1801)	ALS AUS CHN E G HWA >> >>	

1	2	3
(1801)	<< << J JOR PTR RUS AN RUS EO RUS NW TUR UAE USA CL USA E USA SO USA W VIR	
<b>19 759.4</b> <b>(19 758)</b>  (1802)	CHN G HOL ISL J MOZ PTR RUS NW RUS SW RUS W UKR USA CL USA E USA SO VIR	
<b>19 762.4</b> <b>(19 761)</b>  (1803)	ALS AZE B CHN G HWA J JOR KOR LTU POR PTR RUS EO RUS NW RUS SW TKM UAE UKR USA CL USA E USA W VIR	
<b>19 765.4</b> <b>(19 764)</b>  (1804)	ALS BRU CAN W CHN D2 HWA J RUS EO >> >>	ADD

1	2	3
(1804)	<< << S TUR USA SO USA W	ADD
<b>19 768.4</b> <b>(19 767)</b>  (1805)	ALS CHN HWA I J LVA RUS EO RUS SW RUS W TUR USA W	
<b>19 774.4</b> <b>(19 773)</b>  (1807)	ARG CL ARG SO CHN D2 GEO ISL J LVA RUS AN RUS EO RUS NW RUS SW TKM TUR USA SO	
<b>19 777.4</b> <b>(19 776)</b>  (1808)	ALS BLR CHN CUB HWA ISR MCO MDG PTR RUS AN RUS AS RUS EO RUS NW TUR UKR USA CL USA E USA SO USA W VIR	ADD
<b>19 780.4</b> <b>(19 779)</b>  (1809)	ALS B CHN E GRC GUM HWA POL >> >>	ADD

1	2	3
(1809)	<<<< RUS NW RUS W SUI TUR UKR USA E USA SO USA W	
<b>19 783.4</b> <b>(19 782)</b>  (1810)	ALS ARG BUL CHN EST HKG HWA J LTU PTR RUS AN RUS AS RUS SW UKR USA W	
<b>19 786.4</b> <b>(19 785)</b>  (1811)	ALS B CAN E CHN DGA GRC GUM HWA J KOR MDG MDW PTR RUS EO RUS NW TUR UKR USA E USA SO USA W	
<b>19 789.4</b> <b>(19 788)</b>  (1812)	ALS ARG AZE CAN E CHN HWA J MNE PTR RUS EO RUS NW TUR UKR USA E USA SO USA W	

1	2	3
<b>19 792.4</b> <b>(19 791)</b>  (1813)	ALS CHN E F HWA IND E IND W J MDA PTR S TUR USA E USA SO USA W	ADD ADD
<b>19 795.4</b> <b>(19 794)</b>  (1814)	ALS AUS AZE B CHN DGA E GUM HWA ISL MDW MNE PTR RUS EO RUS NW TUR USA E USA SO USA W	
<b>19 798.4</b> <b>(19 797)</b>  (1815)	ARG CL ARG SO AZE BLR CHN GUM J KAZ PTR RUS AN RUS AS RUS EO RUS NW RUS SW TKM UKR USA E USA SO USA W	
<b>22 697.4</b> <b>(22 696)</b>  (2201)	AUS CHN CME E GRC GUM >> >>	

1	2	3
(2201)	<<<< HNG RUS NW USA E USA SO USA W	
<b>22 700.4</b> <b>(22 699)</b>  (2202)	ARG BRM CAN E HNG I IRN MTN NOR RUS EO UKR	ADD
<b>22 703.4</b> <b>(22 702)</b>  (2203)	AUS E BUL DNK IRN J MRC PNR S	ADD
<b>22 706.4</b> <b>(22 705)</b>  (2204)	AFS ARG CAN NO F FIN HRV ISR RUS EO RUS NW	
<b>22 709.4</b> <b>(22 708)</b>  (2205)	ALG AUS EST GRC HOL IRN LTU LVA RUS EO RUS NW RUS W USA E USA SO USA W	
<b>22 712.4</b> <b>(22 711)</b>  (2206)	AFS ALS BHR G GUM HRV HWA IND W J MRC POL PTR >> >>	ADD

1	2	3
(2206)	<<<< USA E USA SO USA W	
<b>22 715.4</b> <b>(22 714)</b>  (2207)	AZR CHN CPV D1 ISR LVA MDR POR RUS SW TLS TUN	
<b>22 718.4</b> <b>(22 717)</b>  (2208)	ARG NO BUL DNK I IND E J MRC NOR PNR S	ADD   ADD
<b>22 721.4</b> <b>(22 720)</b>  (2209)	ALS BEL CHN GRC GUM HWA KOR MRC PNR POL PTR RUS NW USA E USA W	
<b>22 724.4</b> <b>(22 723)</b>  (2210)	E FIN GRC HOL J UKR USA E	
<b>22 727.4</b> <b>(22 726)</b>  (2211)	CHN CUB DNK I J S UKR	
<b>22 730.4</b> <b>(22 729)</b>  (2212)	ALS AUS CYP G >> >>	

1	2	3
(2212)	<<<< GUM HNG HWA MCO PNR PTR SNG USA E USA W	ADD
<b>22 733.4</b> <b>(22 732)</b>  (2213)	BUL CAN E DNK E GEO IRQ LBY LTU NZL RUS EO RUS SW RUS W S TUR	
<b>22 736.4</b> <b>(22 735)</b>  (2214)	BEL CHN E FIN IRN RUS NW SUI TUR URG USA E USA SO USA W	
<b>22 739.4</b> <b>(22 738)</b>  (2215)	CHN F GHA GRC IRQ J NOR POL USA E USA SO USA W	ADD
<b>22 742.4</b> <b>(22 741)</b>  (2216)	CAN W DNK GRC GUM I J MTN USA E USA SO	

1	2	3
<b>22 745.4</b> <b>(22 744)</b>  (2217)	ALS D1 E GRC GUM HKG HWA IRN ISR PNR PTR USA E USA W	
<b>22 748.4</b> <b>(22 747)</b>  (2218)	ALS CHN CYP DNK F GUM HWA PTR S UKR USA E USA SO USA W	
<b>22 751.4</b> <b>(22 750)</b>  (2219)	BEL CHN CUB GRC MCO POL SMO	
<b>22 754.4</b> <b>(22 753)</b>  (2220)	CAN W CHN CZE D2 G GRC SEN SUI SVK	
<b>22 760.4</b> <b>(22 759)</b>  (2222)	ARS AZR CPV D1 FIN GRC KOR MDR MLD POR TLS USA E USA SO USA W	ADD

1	2	3
22 763.4 (22 762)  (2223)	ALS AUS DI HWA I J MLT PTR TUR USA E USA W	ADD
22 766.4 (22 765)  (2224)	ALS D2 E GRC GUM HWA IRQ MAU PNR PTR USA E USA W	
22 769.4 (22 768)  (2225)	ALG BEL CHL GRC IND W ISL J	
22 772.4 (22 771)  (2226)	ALB ALS CHN D2 EGY F HWA ISL JOR ROU USA W	ADD  ADD ADD ADD
22 775.4 (22 774)  (2227)	ALG G GRC IND E J UKR USA E USA SO USA W	
22 778.4 (22 777)  (2228)	AUS DNK GRC MRC QAT >> >>	ADD

1	2	3
(2228)	<< << RUS EO S USA E USA W	
22 781.4 (22 780)  (2229)	BEN BRU CAN E E G IND W J UKR	ADD ADD
22 784.4 (22 783)  (2230)	ALS AUS AZE D2 E GUM HWA KAZ KGZ PNR PTR RUS AS S TUR USA E USA W	
22 787.4 (22 786)  (2231)	ALS ARS CAN W EST F FIN GRC J LVA MLA NIU RUS SW USA E USA SO USA W	
22 790.4 (22 789)  (2232)	CUB GEO GRC HOL IRQ LTU LVA POL RUS EO RUS SW RUS W SUI	

1	2	3
22 793.4 (22 792)  (2233)	ALS CKH GRC GUM HWA IRN NOR PNR PTR ROU USA E USA SO USA W	ADD
22 796.4 (22 795)  (2234)	ARG DNK INS J LBY NOR ROU S	
22 799.4 (22 798)  (2235)	ALS F GRC GUM HWA IRN J PTR QAT RUS NW USA E USA SO USA W	ADD
22 802.4 (22 801)  (2236)	DNK E GRC IRQ J NZL UKR USA E USA W	
22 805.4 (22 804)  (2237)	AZR CHN I IRN J MDR NOR POR ROU USA E USA SO USA W	

1	2	3
22 808.4 (22 807)  (2238)	ALG AUS B DI GRC HNG IRQ J LTU LVA RUS SW RUS W	
22 811.4 (22 810)  (2239)	ALS BEL CHN E GUM HRV HWA IND E IRN NOR PNR PTR USA E USA W	
22 814.4 (22 813)  (2240)	CHL GRC J MDG NOR TUN	
22 817.4 (22 816)  (2241)	ALS AZE CHN CLM GEO HKG HWA J PTR RUS EO RUS NW RUS SW TUR UKR USA CL USA E USA SO USA W VIR VTN	
22 820.4 (22 819)  (2242)	BLR CLM RUS AN >> >>	

1	2	3
(2242)	<< << RUS AS RUS EO RUS NW RUS SW RUS W UKR USA SO	
22 823.4 (22 822)  (2243)	ALS AUS B BUL HWA J KOR PTR RUS EO RUS W UAE USA CL USA E USA SO USA W VIR	
22 826.4 (22 825)  (2244)	ALS HWA I J RUS AN RUS EO UKR USA W	
22 829.4 (22 828)  (2245)	ALS ARG CL ARG SO CHN E HWA J RUS EO UAE USA SO USA W	
22 832.4 (22 831)  (2246)	B J KGZ KOR LVA RUS EO RUS SW RUS W SUI TUR USA SO	

1	2	3
22 835.4 (22 834)  (2247)	ALS CAN E HWA J RUS AN RUS AS RUS EO RUS NW RUS SW UKR USA CL USA E USA SO USA W VIR	
22 838.4 (22 837)  (2248)	ALS CHN E HWA MDA PTR USA E USA SO USA W	ADD
22 841.4 (22 840)  (2249)	ALS CHN HWA I J PTR RUS EO RUS NW RUS W UKR USA E USA SO USA W	
22 844.4 (22 843)  (2250)	ALS AZE B DGA E GRC GUM HWA KAZ KOR MDW MNE PTR RUS EO RUS NW RUS SW TKM TUR >> >>	



1	2	3
(2250)	<< << UKR USA E USA SO USA W	
<b>22 847.4</b> <b>(22 846)</b>  (2251)	ALS B BLR CHN GUM HWA J MCO MDW PTR RUS AN RUS NW RUS SW TUR UKR USA E USA SO USA W	ADD
<b>22 850.4</b> <b>(22 849)</b>  (2252)	ALS G GUM HWA J LVA PTR RUS NW RUS SW TKM UAE UKR USA E USA SO USA W	
<b>22 853.4</b> <b>(22 852)</b>  (2253)	ALS AUS AZE CHN DGA E G GEO GRC GUM HWA J KAZ MDW PTR RUS NW >> >>	

1	2	3
(2253)	<< << RUS W TKM UKR USA E USA SO USA W	
<b>26 146.4</b> <b>(26 145)</b>  (2501)	ALS AZE B CAN E CHN DI HNG HWA JOR MNE RUS EO TUR UKR USA CL USA E USA SO USA W	
<b>26 149.4</b> <b>(26 148)</b>  (2502)	ALS AUS BLR CHN G HWA J MOZ PTR RUS EO RUS SW UKR USA CL USA E USA SO USA W VIR	
<b>26 152.4</b> <b>(26 151)</b>  (2503)	ARG CL BUL CHN J RUS EO SUI UAE USA SO	
<b>26 155.4</b> <b>(26 154)</b>  (2504)	ALS ARG SO B >> >>	

1	2	3
(2504)	<< << BLR CHN HWA J PTR RUS AN RUS AS RUS EO RUS NW RUS SW TKM UKR USA CL USA E USA SO USA W VIR	
<b>26 158.4</b> <b>(26 157)</b>  (2505)	ALS B CHN E GUM HWA IND E IND W ISR PTR RUS EO RUS NW RUS SW RUS W TUR UKR USA E USA SO USA W	
<b>26 161.4</b> <b>(26 160)</b>  (2506)	ALS ARG CHN HWA I J S TUR USA SO USA W	ADD
<b>26 164.4</b> <b>(26 163)</b>  (2507)	ALS ARG AZE CAN E CHN DGA >> >>	

1	2	3
(2507)	<< << E GRC GUM HKG HWA J KAZ MDW PTR RUS EO TKM TUR UKR USA E USA SO USA W	

1	2	3
<b>26 167.4</b> <b>(26 166)</b>	ALS AUS B	
(2508)	CAN W CHN DGA GRC GUM HNG JOR MDW POR PTR RUS EO RUS SW TUR UKR USA E >> >>	

1	2	3
(2508)	<< << USA SO USA W	
<b>26 170.4</b> <b>(26 169)</b>	ALS ARG CL ARG SO	
(2509)	CHN D2 GUM HWA J MDW PTR RUS EO S TUR USA E USA SO USA W	ADD

TABLE OF ALLOTMENTS ADDED TO THE PLAN  
adopted by the WMARC-74

**Column headings**

- 1 Channel number (the corresponding carrier and assigned frequencies are indicated in Sub-section A of Section I of Part B Appendix 17 and in the present Appendix).
- 2 Country or area of allotment.
- 3 Service area description.
  - 3.1 Main service area.
 

A number between 1 and 22 refers to a Zone defined on the Map of Maritime Zones appearing in the Preface to the BR IFIC.
  - 3.2 Maximum length of circuit in kilometres.
- 4 Nature of service.
- 5 Class of emission.
- 6 Peak envelope power in dBW.
- 7 Transmitting antenna characteristics.
  - 7.1 In the case of a non-directional antenna, the symbol ND is entered in this column and columns 7.2a), b) and c) are left blank. In the case of a directional antenna, the symbol D is entered in this column and the characteristics are given in columns 7.2a), b) and c).
  - 7.2a) Azimuth of maximum radiation. The symbol ROT entered in this column means that a rotatable antenna is used.
  - 7.2b) Angular width of main lobe.
  - 7.2c) Relative gain of the antenna in dB.
- 8 Planned scheduled hours of operation in the channel (UTC).
- 9 Traffic data.
  - 9a) Estimated peak hours of traffic.
  - 9b) Estimated daily volume of traffic in minutes.
- 10 Special section No./Weekly Circular or BR IFIC No./Date (e.g. MAR/10/1305/280278). (WRC-03)

1	2	3		4	5	6	7				8	9		10
		3.1	3.2				7.1	7.2 a)	7.2 b)	7.2 c)		9a)	9b)	
401	AUS	12	800	CV	J3E	20.0	ND				2200-1000	2200-1000	30	MAR/54/1640/021084
401	PNR	9, 18	500	CP	J3E	30.0	ND				0000-1200		25	AR16/84/1838/160888
402	BEN	19	-	CP	J3E	30.0	ND				0000-2359	2000-0800	40	AP25/133/2520/010604
403	CAN CL	2, 16	1 000	CV	J3E	30.0	ND				0000-2359	0800-2000	360	AR16/120/2318/100398
403	PNR	9, 18	500	CP	J3E	30.0	ND				0800-1200		25	AR16/84/1838/160888
404	MCO	17	300	CP	J3E	40.0	ND				0700-2200	0800-1000 1500-1700	50	AP25/125/2379/250599
405	USA CL	16	800	CP	J3E	30.0	ND				1100-2300 2300-1100	1200-1800	180	MAR/50/1609/280284
407	AUS	11, 12	800	CO/CP	J3E	37.0	ND				0000-2400			MAR/48/1602/100184
407	I	17	1 200	CO	J3E	31.8	ND				0500-2200	0700-1100	60	MAR/58/1682/300785
408	B	18, 20	800	CV	J3E	21.8	ND				0000-2400		120	MAR/69/1712/040386
408	CHN	5	200	OT	J3E	26.0	D	340	60	3	1100-1900	1200-1300	190	
408	MDA	17	-	CO	J3E	30.0	ND				0000-2400	0300-2000	180	AP25/142/2692/190411
408	MLD	6	-	CO	J3E	30.0	D	300	120	5	0000-2400			AR16/79/1816/150388
408	SMA	8, 12, 13	1 000	CP	J3E	30.0	ND				1800-0400		30	MAR/10/1305/280278
409	GHA	19	500	CP	J3E	30.0	ND				0000-2359			AR16/114/2237/230796
409	QAT	6	2 500	CP	J3E	30.0	ND							AR16/89/1886/250789
411	AMS	10	-	CP	J3E	24.8	ND				0430-0445 0830-0845 1230-1245		25	MAR/15/1347/191278
411	EQA	9	800	CP	J3E	24.0	ND				0030-0530		30	AR16/90/1895/260989
411	I	17	-	CO	J3E	31.8	ND				0500-2200	0700-1100	60	AR16/75/1747/041186
411	KIR	7, 8	500	CP	J3E	27.0	ND				0800-1800			MAR/59/1686/270885
416	ARG CL	14, 20	1 000	CP	J3E	30.0	D	90	60	2	0000-2400	1100-1700	490	
417	TZA	6, 10, 19, 21	3 200	CO/CP	J3E	37.0	ND				0700-1800	0800-1000 1500-1700	240	MAR/66/1707/280186
418	B	18, 20	800	CV	J3E	21.8	ND				0000-2400	0700-1100	240	MAR/69/1712/040386
418	I	17	-	CO	J3E	31.8	ND				0500-2200	0700-1100	60	AR16/75/1747/041186
419	TZA	6, 10, 19, 21	3 200	CO/CP	J3E	37.0	ND				0700-1800	0800-1000 1500-1700	240	MAR/57/1680/160785
422	SUI	15, 16, 17, 18, 19	4 000	CP	J2D	37.0	D	ROT	30	8	0000-2400	1900-0200	240	AP25/147/2718/010512
423	B	18, 20	800	CV	J3E	27.0	ND				0000-2400			MAR/16/1350/160179
423	MLT	6, 15, 17	3 000	CP	J3E	31.8	ND				1700-0500	2000-2100	60	MAR/41/1565/190483
423	QAT	6	800	CP	J3E	37.0	ND				0000-2400		200	MAR/23/1412/010480
		6	1 500	CP	J3E	37.0	D	130	60	9	0000-2400		200	
		6	1 500	CP	J3E	37.0	D	200	60	9	0000-2400		200	
		6	1 500	CP	J3E	37.0	D	310	60	9	0000-2400		200	
424	AUS E	12	800	CO/CP	J3E	30.0	ND				0000-2400			MAR/48/1602/100184
424	PNR	9, 18	500	CP	J3E	30.0	ND				0800-1200		25	AR16/73/1742/300986
425	B	18, 20	800	CV	J3E	27.0	ND				1000-2300	1900-2200	100	MAR/16/1350/160179
425	JOR	6, 15, 17	5 000	CP	J3E	37.0	ND				1700-0500			MAR/49/1604/240184
428	BRU	7	1200	CP	J3E	21.76	ND				2100-1400	2200-0100	100	AP25/141/2691/050411
601	CANNO	02, 04, 16	-	CP	J3EJN	29.2	ND				0000-2400	0800-2000	20	AP25/149/2731/301012
601	I	17	-	CO	J3E	31.8	ND				0400-2200	0600-1400	60	AR16/75/1747/041186
601	MLD	6	-	CO	J3E	30.0	D	300	120	5	0000-2400			AR16/79/1816/150388
601	NCL	7, 8, 12	2 500	CP	J3E	27.0	ND				0000-2400			AR16/71/1737/260886
602	AUS E	12	1 000	CV	J3E	26.0	ND				0000-2359	1900-0700		AP25/128/2406/301199

AP25-32

1	2	3		4	5	6	7				8	9		10
		3.1	3.2				7.1	7.2 a)	7.2 b)	7.2 c)		9a)	9b)	
602	B	18, 20	800	CP	J3E	30.0	ND				0000-2400			MAR/69/1712/040386
602	EQA	9	800	CP	J3E	24.0	ND				0630-1000		30	AR16/90/1895/260989
602	FJI	12	1 000	CP	J3E	30.0	ND				1800-0600	2000-0500	120	MAR/37/1519/180582
602	GHA	19	500	CP	J3E	30.0	ND				0000-2359			AR16/114/2237/230796
							D							
							D	110		30				
								330		30				
603	AUS	11, 12	4 000	CP	J3E	30.0	ND				0000-2400	2100-0900	30	MAR/55/1651/181284
603	MLT	6, 15, 17	3 000	CP	J3E	31.8	ND				0500-1700	0900-1100	60	MAR/41/1565/190483
603	VTN	5, 6, 7	-	CP	J3E	34.8	ND				0000-2400	0630-1700	230	AP25/146/2710/100112
604	B	18, 20	800	CP	J3E	30.0	ND				1000-1300			MAR/69/1712/040386
											1700-2000			
604	BES	18	1 500	CP	J3E	30.0	ND				0000-0200		120	MAR/35/1495/171181
											0600-1000			
604	CUW	18	1 500	CP	J3E	30.0	ND				0000-0200		120	MAR/35/1495/171181
											0600-1000			
604	RUS EO	01, 03, 05	1 500	CP	J3E	30.0	ND				0000-2400	0000-2400	200	AP25/151/2742/160413
604	SXM	18	1 500	CP	J3E	30.0	ND			2.7	0000-0200		120	MAR/35/1495/171181
											0600-1000			
604	TUV	8, 12	450	CP	J3E	30.0	ND				1800-1200	2000-0400	30	AR16/91/1897/101089
604	VTN	5, 6, 7, 10, 11	-	CP	J3E	30.0	ND				0000-2400	0100-0400	600	AP25/137/2632/111108
											1000-1800			
605	B	18, 20	800	CP	J3E	30.0	ND				1000-1300			MAR/69/1712/040386
											1700-2000			
605	F	15, 17	2 500	CP	J3E	40.0	ND				0600-0900	1800-2200	300	MAR/56/1679/090785
											1700-2200			
605	NZL	7, 8, 11, 12, 13	6 000	CP	J3E	37.0	ND				0000-2400	0400-0900	90	MAR/63/1695/291085
607	MDA	17	-	CO	J3E	30.0	ND				0000-2400	0300-2000	180	AP25/142/2692/190411
608	BRU	7, 11	1 300	CP	J3E	21.76	ND				2100-1400	2200-0100	100	AP25/141/2691/050411
802	MDA	17	-	CO	J3E	30.0	ND				0000-2400	0300-2000	180	AP25/142/2692/190411
803	SUI	15, 16, 17, 18, 19	6 000	CP	J3E	40.0	D	ROT			0600-0200	0600-1000	50	MAR/62/1694/221085
											1700-2200			
804	JOR	6, 15, 17	5 000	CP	J3E	37.0	ND				0500-1700			MAR/49/1604/240184
804	QAT	6	1 500	CP	J3E	37.0	ND				0000-2400		200	MAR/23/1412/010480
		6	2 500	CP	J3E	37.0	D		130	60	0000-2400		200	
		6	2 500	CP	J3E	37.0	D		200	60	0000-2400		200	
		6, 17	2 500	CP	J3E	37.0	D		310	60	0000-2400		200	
805	EQA	9	800	CP	J3E	24.0	ND				1130-1730		30	AR16/90/1895/260989
806	AUS	11	2 000	CP	J3E	30.0	ND				2100-0500	2100-0500	90	MAR/52/1631/310784
806	SMA	8, 12, 13	3 000	CP	J3E	30.0	ND				1800-0400		30	MAR/11/1310/040478
807	I	15, 17	-	CO	J3E	31.8	ND				0000-2400	0500-1300	60	AR16/75/1747/041186
808	I	15, 17	-	CO	J3E	31.8	ND				0000-2400	1300-2100	60	AR16/75/1747/041186
811	BEN	19	-	CP	J3E	30.0	ND				0000-2359	0800-2000	40	AP25/133/2520/010604
812	I	15, 17	-	CO	J3E	31.8	ND				0000-2400	2100-0500	60	AR16/75/1747/041186
813	VTN	5, 6, 7, 10, 11	-	CP	J3E	30.0	ND				0000-2400	0100-0400	650	AP25/137/2632/111108
											1100-1400			
814	KIR	7, 8	500	CP	J3E	27.0	ND				1800-0800			MAR/65/1702/171285
815	JOR	6, 17	3 000	CP	J3E	37.0	ND				0700-2000	0800-1200	60	AR16/100/2084/060793
817	PNR	9, 18	2 000	CP	J3E	30.0	ND				1200-2300		25	AR16/84/1838/160888
819	PNR	9, 18	2 000	CP	J3E	30.0	ND				1200-2300		25	AR16/84/1838/160888

1	2	3		4	5	6	7				8	9		10
		3.1	3.2				7.1	7.2 a)	7.2 b)	7.2 c)		9a)	9b)	
820	D2	6, 15, 16, 17, 18, 19	6 000	CP	J3E	40.0	ND				0400-2000		30	AR16/82/1827/310588
820	TZA	6, 10, 19, 21	3 200	CO/CP	J3E	37.0	ND				0700-1800	0800-1000 1500-1700	240	MAR/66/1707/280186
822	AUS	11, 12	3 000	CP	J3E	30.0	ND				2100-0900	2100-0900	90	MAR/64/1696/051185
823	TZA	6, 10, 19, 21	3 200	CO/CP	J3E	30.0	ND				0700-1800	0800-1000 1500-1700	240	MAR/66/1707/280186
823	USA W	9	1 200	CO	J3E	30.0	ND				1600-0400	1600-1800 0000-0200	180	AR16/92/1910/230190
825	AMS	10	-	CP	J3E	24.8	ND				0445-0500 0845-0900 1245-1300 0000-2359		25	MAR/15/1347/191278
825	GHA	19	500	CP	J3E	30.0	ND							AR16/114/2237/230796
825	S	5, 15 5, 15 6, 10, 17 6, 10, 17, 19, 21 15, 16, 17, 18, 19, 21 15, 16, 18, 19 15, 16	-	CP	J3E	40.0	D	110 330	30	10	0000-2400	0800-1000	90	AR16/70/1730/080786
						40.0	D	50	60	11	0000-2400	0800-1000	90	
						40.0	D	130	60	11	0000-2400	0800-1000	90	
						40.0	D	170	60	11	0000-2400	0800-1000	90	
						40.0	D	210	60	11	0000-2400	0800-1000	90	
						40.0	D	250	60	11	0000-2400	0800-1000	90	
						40.0	D	310	60	11	0000-2400	0800-1000	90	
826	CANNO	02, 04, 16	-	CP	J3EJN	29.2	ND				0000-2400	0800-2000	20	AP25/148/2720/290512
826	QAT	6	2 500	CP	J3E	30.0	ND				0000-2400			AR16/89/1886/250789
829	BRM	5, 6, 7	3 300	CP	J3E	24.0	ND				2330-1130	0330-0430	30	AR16/112/2223/160496
829	MLD	6	-	CO	J3E	30.0	D	300	120	5	0000-2400			AR16/79/1816/150388
830	CHN	5, 6, 7, 8	8 000	CP	J3E	38.5	ND				0000-2400	0000-0800	400	
830	MCO	15, 17	800	CP	J3E	40.0	ND				0700-2200	0800-1000 1500-1700	50	AP25/125/2379/250599
830	VTN	5, 6, 7	-	CP	J3E	30.0	ND				0000-2400	0800-1800	320	AP25/146/2710/100112
834	BHR	6	-	CO	J3E	30.0	ND				0001-2400	1300-0100	300	AP25/145/2707/151111
835	BRU	7, 11	1500	CP	J3E	21.76	ND				2100-1400	2200-0100	100	AP25/141/2691/050411
1 201	QAT	6	2 500	CP	J3E	30.0	ND				0400-0600 1400-1600			AR16/89/1886/250789
1 207	EQA	9	800	CP	J3E	24.0	ND				1830-2330		30	AR16/90/1895/260989
1 208	I	6, 15, 16, 17, 18	-	CO	J3E	31.8	ND				0300-2200	0600-1100	30	AR16/75/1747/041186
1 210	SUI	6, 10, 15, 16, 17, 18, 19, 20, 21	9 000	CP	J3E	40.0	D	ROT	30	8	0600-0200	0800-1200 1600-2100	60	MAR/62/1694/221085
1 212	MDA	17	-	CO	J3E	30.0	ND				0000-2400	0300-2000	180	AP25/142/2692/190411
1 212	RUS AS	01	2 500	OT	J3E	33.0	D	346	60	1.5	0000-2400	0000-2400	100	AP25/153/2869/010518
1 213	USA W	9	1 600	CO	J3E	30.0	ND				1800-2300	2100-2200	180	AR16/95/1996/011091
1 215	BHR	6	-	CO	J3E	37.0	ND				0001-2400	1300-0100	300	AP25/145/2707/151111
1 220	D2	6, 15, 16, 17, 18, 19	6 000	CP	J3E	40.0	ND				0400-2000		30	AR16/82/1827/310588
1 220	JOR	6, 15, 17	5 000	CP	J3E	37.0	ND				0500-1700			MAR/49/1604/240184
1 222	ALS	4	1 600	CO	J3E	30.0	ND				2000-0100	2300-2400	180	AR16/95/1996/011091
1 222	BEN	19	-	CP	J3E	30.0	ND				0000-2359	0800-2000	20	AP25/133/2520/010604
1 222	USA W	9	1 600	CO	J3E	30.0	ND				1800-2300	2100-2200	180	AR16/95/1996/011091
1 224	GHA	19	500	CP	J3E	30.0	ND				0000-2359			AR16/114/2237/230796
1 225	JOR	6, 10	5 000	CP	J3E	37.0	D	110 330 144	30	10	0900-1700	1300-1500	30	AR16/100/2084/060793

AP25-34

1	2	3		4	5	6	7				8	9		10	
		3.1	3.2				7.1	7.2 a)	7.2 b)	7.2 c)		9a)	9b)		
1 226	MCO	01, 02, 06, 15, 16, 17, 18, 19	6 000	CP	J3E	40.0	ND					0700-2200	0800-1000 1500-1700	50	AP25/125/2379/250599
1 226	S	5, 15 5, 15 6, 10, 17 6, 10, 17, 19, 21 15, 16, 17, 18, 19, 21 15, 16, 18, 19, 15, 16	-	CP	J3E	40.0 40.0 40.0 40.0 40.0 40.0	D D D D D D	10 50 130 170 210 250 310	60 60 60 60 60 60 60	11 11 11 11 11 11 11		0000-2400 0000-2400 0000-2400 0000-2400 0000-2400 0000-2400 0000-2400	0800-1000 0800-1000 0800-1000 0800-1000 0800-1000 0800-1000 0800-1000	90 90 90 90 90 90 90	AR16/70/1730/080786
1 227	TZA	6, 10, 19, 21	3 200	CO/CP	J3E	37.0	ND					0700-1800	0800-1000 1500-1700	240	MAR/66/1707/280186
1 228	I	6, 15, 16, 17, 18	-	CO	J3E	31.8	ND					2200-0500	2300-0200	30	AR16/75/1747/041186
1 228	MLD	6	-	CO	J3E	30.0	D	300	120	5		0000-2400			AR16/79/1816/150388
1 228	VTN	5, 6, 7, 10, 11	-	CP	J3E	37.0	ND					0000-2400	0100-0400 1000-1800	800	AP25/137/2632/111108
1 229	QAT	6, 17	2 000	CP	J3E	37.0	ND					0400-0600 1400-1600		200	MAR/23/1412/010480
		6	3 000	CP	J3E	37.0	D	130	60	11		0400-0600 1400-1600			
		6, 17	3 000	CP	J3E	37.0	D	200	60	11		0400-0600 1400-1600			
		6, 17	3 000	CP	J3E	37.0	D	310	60	11		0400-0600 1400-1600 0000-2400			
1 231	VTN	5, 6, 7	-	CP	J3E	30.0	ND					0000-2400	0000-1500	398	AP25/146/2710/100112
1 232	PNR	9, 14, 16, 18	4 000	CP	J3E	30.0	ND					1200-2400		25	AR16/84/1838/160888
1 232	SMA	8, 12, 13	3 000	CP	J3E	30.0	ND					1800-0400		30	MAR/11/1310/040478
1 236	BRM	5, 6, 7	3 300	CP	J3E	24.0	ND					2330-1130	0330-0430	30	AR16/112/2223/160496
1 238	MCO	15, 16, 17	5 000	CP	J3E	40.0	ND					0700-2200	0800-1600	120	AP25/129/2445/290501
1239	BRU	5, 7, 11	2000	CP	J3E	21.76	ND					2100-1400	2200-0100	100	AP25/141/2691/050411
1 603	MLT	15, 17	3 000	CP	J3E	31.8	ND					0000-1159			MAR/21/1379/070879
1 604	BEN	19	-	CP	J3E	30.0	ND					0000-2359		20	AP25/133/2520/010604
1 608	EQA	9, 14	800	CP	J3E	27.0	ND					1800-2300	2000-2300	40	AR16/111/2221/020496
1 612	JOR	6, 10	6 000	CP	J3E	37.0	D	144	60	9		1000-1600	1300-1500	20	AR16/100/2084/060793
1 614	MLD	6	-	CO	J3E	30.0	D	300	120	5		0000-2400			AR16/79/1816/150388
1 622	ALS	4	2 400	CO	J3E	30.0	ND					2000-0600	0200-0300	180	AR16/95/1996/011091
1 622	GHA	19	500	CP	J3E	30.0	ND					0000-2359			AR16/114/2237/230796
1 622	HWA	8	2 400	CO	J3E	30.0	ND					2000-0600	0200-0300	180	AR16/95/1996/011091
1 622	PNR	9, 14, 16, 18	4 000	CP	J3E	30.0	ND					1200-2400		25	AR16/84/1838/160888
1 622	SUI	3, 4, 5, 6, 7, 9, 10, 15, 16, 17, 18, 19, 20, 21	10 000	CP	J3E	40.0	D	ROT	30	8		0600-0200	0800-1700	60	MAR/62/1694/221085
1 626	J	3, 4, 5, 6, 7, 8, 9, 10, 11, 12, 13, 14	-	CR	J3E	37.0	ND					0000-2400	0800-1000	500	
1 626	QAT	6, 17	4 000	CP	J3E	40.0	ND					0600-0800 1200-1400		200	MAR/23/1412/010480
		6	6 000	CP	J3E	40.0	D	130	60	11		0600-0800 1200-1400			
		6, 10, 17	6 000	CP	J3E	40.0	D	200	60	11		0600-0800 1200-1400			
		6, 15, 17	6 000	CP	J3E	40.0	D	310	60	11		0600-0800 1200-1400			

1	2	3		4	5	6	7				8	9		10
		3.1	3.2				7.1	7.2 a)	7.2 b)	7.2 c)		9a)	9b)	
1 627	ALS	4	2 400	CO	J3E	30.0	ND				2000-0600	0200-0300	180	AR16/95/1996/011091
1 628	EQA	9, 14	800	CP	J3E	27.0	ND				1800-2300	2000-2300	40	AR16/111/2221/020496
1 628	MCO	01, 02, 06, 15, 16, 17, 18, 19	6 000	CP	J3E	40.0	ND				0700-2200	0800-1000 1400-1600	50	AP25/125/2379/250599
1 629	BRM	5, 6, 7	3 300	CP	J3E	24.0	ND				2330-1130	0330-0430	30	AR16/112/2223/160496
1 630	J	3, 4, 5, 6, 7, 8, 9, 10, 11, 12, 13, 14	–	CR	J3E	37.0	ND				0000-2400	0300-0700	650	
1 634	CHN	8, 9, 10, 11, 12, 13, 14, 15, 17, 19, 20, 21	19 000	CP	J3E	40.0	ND				0000-1000	0200-0600	200	
1 635	I	5, 6, 7, 9, 10, 14, 15, 16, 18, 20, 21	–	CO	J3E	31.8	ND				0400-2400	0600-1600	30	AR16/75/1747/041186
1 635	PNR	9, 14, 16, 18	4 000	CP	J3E	30.0	ND				1500-2400		25	AR16/84/1838/160888
1 637	CHN	8, 9, 10, 11, 12, 13, 14, 15, 17, 19, 20, 21	19 000	CP	J3E	40.0	ND				0000-1000	0200-0600	200	
1 638	SMA	8, 12, 13	4 000	CP	J3E	30.0	ND				1800-0400		30	MAR/10/1305/280278
1 638	D2	6, 15, 16, 17, 18, 19	6 000	CP	J3E	40.0	ND				0400-2000		30	AR16/82/1827/310588
1 639	CHN	5	800	OT	J3E	31.8	D	90	60	3	0000-1200	0100-0230	300	
1 640	PNR	9, 14, 16, 18	4 000	CP	J3E	30.0	ND				1500-2400		25	AR16/84/1838/160888
1 644	MDA	17	–	CO	J3E	30.0	ND				0000-2400	0300-2000	180	AP25/142/2692/190411
1 646	VTN	5, 6, 7, 10, 11	–	CP	J3E	37.0	ND				0000-2400	0830-1630	750	AP25/137/2632/111108
1 804	BRU	5, 6, 7, 10, 11, 12	5000	CP	J3E	21.76	ND				2100-1400	2200-0100	100	AP25/141/2691/050411
1 804	S	06, 15, 16, 17, 18, 19	7 000	CP	J3E	38.5	ND				0000-2359	0600-1900	120	AP25/126/2388/270799
1 808	MCO	15, 16, 17	5 000	CP	J3E	40.0	ND				0700-2200	0800-1600	120	AP25/129/2445/290501
1 809	POL	5, 11, 21	20 000	CP	J3E	40.0	ND				0000-2230	1730-2230	90	AR16/119/2310/130198
1 813	MDA	17	–	CO	J3E	30.0	ND				0000-2400	0300-2000	180	AP25/142/2692/190411
1 813	S	06, 15, 16, 17, 18, 19	7 000	CP	J3E	38.5	ND				0000-2359	0600-1900	120	AP25/130/2445/290501
2 202	BRM	5, 6, 7	3 300	CP	J3E	24.0	ND				2330-1130	0330-0430	30	AR16/112/2223/160496
2 203	PNR	9, 14, 16, 18	4 000	CP	J3E	30.0	ND				1500-2400		25	AR16/84/1838/160888
2 206	BHR	6, 10, 15, 17, 19, 21	–	CP	J3E	34.8	ND				0000-2359			AR16/100/2084/060793
2 208	I	5, 6, 7, 9, 10, 14, 15, 16, 18, 20, 21	–	CO	J3E	31.8	ND				0500-2400	0700-2200	30	AR16/75/1747/041186
2 208	PNR	9, 14, 16, 18	4 000	CP	J3E	30.0	ND				1200-2400		25	AR16/84/1838/160888
2 209	CHN	4, 9, 10, 11, 12, 13, 14, 15, 17, 19, 20, 21	19 000	CP	J3E	40.0	ND				0000-1000	0200-0600	200	
2 211	CHN	4, 9, 10, 11, 12, 13, 14, 15, 17, 19, 20, 21	18 000	CP	J3E	40.0	ND				0000-1000	0200-0600	240	



AP25-36

1	2	3		4	5	6	7				8	9		10
		3.1	3.2				7.1	7.2 a)	7.2 b)	7.2 c)		9a)	9b)	
2 212	MCO	01, 02, 06, 10, 15, 16, 17, 18, 19, 20, 21	8 000	CP	J3E	40.0	ND				0700-2200	0800-1000 1400-1600	50	AP25/125/2379/250599
2 215	CHN	4, 9, 10, 11, 12, 13, 14, 15, 17, 19, 20, 21	19 000	CP	J3E	40.0	ND				0000-1000	0200-0600	200	
2 215	GHA	19	500	CP	J3E	30.0	ND D D	110 330	30 30	10 10	0000-2359			AR16/114/2237/230796
2 218	CHN	4, 9, 10, 11, 12, 13, 14, 15, 17, 19, 20, 21	19 000	CP	J3E	40.0	ND				0000-1000	0200-0600	200	
2 220	CHN	4, 9, 10, 11, 12, 13, 14, 15, 17, 19, 20, 21	19 000	CP	J3E	40.0	ND				0000-1000	0200-0600	240	
2 220	SUI	6, 10, 18, 20, 21	14 000	CP	J3E	40.0	D	ROT	70	8,5	0600-1800	0900-1600	60	MAR/27/1431/120880
2 222	MLD	6	-	CO	J3E	30.0	D	300	120	5	0000-2400			AR16/79/1816/150388
2 223	MLT	15, 17	3 000	CP	J3E	31.8	ND				0000-1159			MAR/20/1372/190679
2 226	ALS	4	2 400	CO	J3E	30.0	ND				2000-0400	0100-0200	180	AR16/95/1996/011091
2 226	HWA	8	2 400	CO	J3E	30.0	ND				2000-0400	0100-0200	180	AR16/95/1996/011091
2 226	JOR	6, 10, 11	8 000	CP	J3E	37.0	D	144	60	9	1100-1400			AR16/100/2084/060793
2 226	USA W	9	2 400	CO	J3E	30.0	ND				1800-0200	2300-2400	180	AR16/95/1996/011091
2 228	QAT	6, 10, 11	2 500	CP	J3E	33.0	D	140	60	10	0000-1800	0400-1100		AR16/96/1997/081091
2 229	BEN	19	-	CP	J3E	30.0	ND				0000-2359		20	AP25/133/2520/010604
2 229	BRU	5, 6, 7, 8, 10, 11, 12	6000	CP	J3E	21.76	ND				2100-1400	2200-0100	100	AP25/141/2691/050411
2 233	GRC	17	2 600	CO	J3E	30.0	ND				0500-2200	0600, 1000, 2200	30	MAR/51/1621/220584
2 235	QAT	6, 17 6, 10, 11 6, 10, 17, 21 17, 15	5 000 8 000 8 000 8 000	CP CP CP CP	J3E J3E J3E J3E	40.0 40.0 40.0 40.0	ND D D D		130 200 310	60 60 60	11 11 11	0800-1200 0800-1200 0800-1200 0800-1200	200 200 200 200	MAR/23/1412/010480
2 237	CHN	4, 9, 10, 11, 12, 13, 14, 15, 17, 19, 20, 21	19 000	CP	J3E	40.0	ND				0000-1000	0200-0600	200	
2 239	CHN	7	2 700	CP	J3E	20.0	ND				0100-0930	0200-0400	280	
2 248	MDA	17	-	CO	J3E	30.0	ND				0000-2400	0300-2000	180	AP25/142/2692/190411
2 251	MCO	15, 16, 17	5 000	CP	J3E	40.0	ND				0700-2200	0800-1600	120	AP25/129/2445/290501
2 506	S	06, 15, 16, 17, 18, 19	7 000	CP	J3E	38.5	ND				0000-2359	0600-1900	120	AP25/130/2445/290501
2 509	S	06, 15, 16, 17, 18, 19	7 000	CP	J3E	38.5	ND				0000-2359	0600-1900	120	AP25/126/2388/270799

## APPENDIX 26 (REV.WRC-15)\*

**Provisions and associated Frequency Allotment Plan for the aeronautical mobile (OR) service in the bands allocated exclusively to that service between 3 025 kHz and 18 030 kHz**

(See Article 43)

**PART I – General provisions, definitions**

**26/1** The provisions of this Appendix shall apply to the aeronautical mobile (OR) service in the following frequency bands:

3 025-3 155 kHz	8 965- 9 040 kHz
3 900-3 950 kHz (Region 1 only)	11 175-11 275 kHz
4 700-4 750 kHz	13 200-13 260 kHz
5 680-5 730 kHz	15 010-15 100 kHz
6 685-6 765 kHz	17 970-18 030 kHz.

**26/2** For the purpose of this Appendix, the terms used comprise the following:

**26/2.1 Frequency Allotment Plan**

The Plan for the aeronautical mobile (OR) service contained in Part III of this Appendix.

**26/2.2 Allotment in the aeronautical mobile (OR) service**

A frequency allotment in the aeronautical mobile (OR) service which comprises:

- a frequency channel from the channels appearing in the channelling arrangement in No. 26/3;
- a bandwidth of up to 2.8 kHz, situated wholly within the frequency channel concerned;
- a power within the limits laid down in No. 26/4.4 or specified against the allotted frequency channel;
- an allotment area which is the area in which the aeronautical station can be situated and which coincides with all or part of the territory of the country, or of the geographical area, as indicated against the frequency channel concerned in the Frequency Allotment Plan.

---

\* This revision contains an up-to-date version of Part III, reflecting all amendments to Part III resulting from the application of the procedures of Part V, up to and including 10 May 2016, as well as those amendments, which resulted from geopolitical changes that occurred up to and including that date.

**PART II – Technical bases used for the establishment of the Frequency Allotment Plan for the aeronautical mobile (OR) service in the bands allocated exclusively to that service between 3 025 kHz and 18 030 kHz**

**26/3 Channelling arrangement**

**26/3.1** The channelling arrangement for the frequencies to be used by aeronautical stations in the aeronautical mobile (OR) service in the bands allocated exclusively to that service between 3 025 kHz and 18 030 kHz is indicated in Table 1.

TABLE 1

**Frequency band 3 025-3 155 kHz: 43 + 1 channels**

3 023 <sup>1</sup>	3 026	3 029	3 032	3 035	3 038	3 041	3 044	3 047	3 050
3 053	3 056	3 059	3 062	3 065	3 068	3 071	3 074	3 077	3 080
3 083	3 086	3 089	3 092	3 095	3 098	3 101	3 104	3 107	3 110
3 113	3 116	3 119	3 122	3 125	3 128	3 131	3 134	3 137	3 140
3 143	3 146	3 149	3 152						

**Frequency band 3 900-3 950 kHz (Region 1 only): 16 channels**

3 900	3 903	3 906	3 909	3 912	3 915	3 918	3 921	3 924	3 927
3 930	3 933	3 936	3 939	3 942	3 945				

**Frequency band 4 700-4 750 kHz: 16 channels**

4 700	4 703	4 706	4 709	4 712	4 715	4 718	4 721	4 724	4 727
4 730	4 733	4 736	4 739	4 742	4 745				

**Frequency band 5 680-5 730 kHz: 15 + 1 channels**

5 680 <sup>1</sup>	5 684	5 687	5 690	5 693	5 696	5 699	5 702	5 705	5 708
5 711	5 714	5 717	5 720	5 723	5 726				

**Frequency band 6 685-6 765 kHz: 26 channels**

6 685	6 688	6 691	6 694	6 697	6 700	6 703	6 706	6 709	6 712
6 715	6 718	6 721	6 724	6 727	6 730	6 733	6 736	6 739	6 742
6 745	6 748	6 751	6 754	6 757	6 760				

**Frequency band 8 965-9 040 kHz: 25 channels**

8 965	8 968	8 971	8 974	8 977	8 980	8 983	8 986	8 989	8 992
8 995	8 998	9 001	9 004	9 007	9 010	9 013	9 016	9 019	9 022
9 025	9 028	9 031	9 034	9 037					

**Frequency band 11 175-11 275 kHz: 33 channels**

11 175	11 178	11 181	11 184	11 187	11 190	11 193	11 196	11 199	11 202
11 205	11 208	11 211	11 214	11 217	11 220	11 223	11 226	11 229	11 232
11 235	11 238	11 241	11 244	11 247	11 250	11 253	11 256	11 259	11 262
11 265	11 268	11 271							

**Frequency band 13 200-13 260 kHz: 20 channels**

13 200	13 203	13 206	13 209	13 212	13 215	13 218	13 221	13 224	13 227
13 230	13 233	13 236	13 239	13 242	13 245	13 248	13 251	13 254	13 257

**Frequency band 15 010-15 100 kHz: 30 channels**

15 010	15 013	15 016	15 019	15 022	15 025	15 028	15 031	15 034	15 037
15 040	15 043	15 046	15 049	15 052	15 055	15 058	15 061	15 064	15 067
15 070	15 073	15 076	15 079	15 082	15 085	15 088	15 091	15 094	15 097

**Frequency band 17 970-18 030 kHz: 20 channels**

17 970	17 973	17 976	17 979	17 982	17 985	17 988	17 991	17 994	17 997
18 000	18 003	18 006	18 009	18 012	18 015	18 018	18 021	18 024	18 027

<sup>1</sup> For use of the carrier (reference) frequencies 3 023 kHz and 5 680 kHz, see No. 26/3.4.

**26/3.2** The frequencies indicated in No. **26/3.1** are the carrier (reference) frequencies.

**26/3.3** With the exception of the carrier (reference) frequencies 3 023 kHz and 5 680 kHz (see No. **26/3.4**), one or more frequencies from Table 1 may be assigned to any aeronautical station and/or aircraft station, in accordance with the Frequency Allotment Plan, as contained in Part III of this Appendix.

**26/3.4** The carrier (reference) frequencies 3 023 kHz and 5 680 kHz are intended for worldwide common use (see also Appendix **27**, Nos. **27/232** to **27/238**).

**26/3.5** The aeronautical radiotelephone stations shall use only single-sideband emissions (J3E). The upper sideband shall be employed, and the assigned frequency (see No. 1.148) shall be 1 400 Hz higher than the carrier (reference) frequency.

**26/3.6** The channelling arrangement specified in No. **26/3.1** does not prejudice the rights of administrations to establish, and to notify assignments to stations in the aeronautical mobile (OR) service other than those using radiotelephony, provided that:

- the occupied bandwidth does not exceed 2 800 Hz and is situated wholly within one frequency channel;
- the limits of unwanted emission are met (see Appendix **27**, No. **27/74**). (WRC-2000)

## **26/4 Classes of emission and power**

**26/4.1** In the aeronautical mobile (OR) service, in the bands governed by this Appendix, the use of the emissions listed below is permissible; additionally, the use of other emissions is also permissible, subject to compliance with No. **26/3.6**.

### **26/4.2 Telephony**

- J3E (single-sideband, suppressed carrier).

### **26/4.3 Telegraphy (including automatic data transmission)**

- A1A, A1B, F1B;
- (A,H)2(A,B);
- (R,J)2(A,B,D);
- J(7,9)(B,D,X).

## AP26-4

26/4.4 Unless otherwise specified in Part III of this Appendix, the following transmitter power limits (i.e. power supplied to the antenna), shall be applied:

Class of emission	Power limit values (peak envelope power supplied to the antenna)	
	Aeronautical station	Aircraft station
J3E	36 dBW (PX)	23 dBW (PX)
A1A, A1B	30 dBW (PX)	17 dBW (PX)
F1B	30 dBW (PX)	17 dBW (PX)
A2A, A2B	32 dBW (PX)	19 dBW (PX)
H2A, H2B	33 dBW (PX)	20 dBW (PX)
(R,,J)2(A,B,D)	36 dBW (PX)	23 dBW (PX)
J(7,9)(B,D,X)	36 dBW (PX)	23 dBW (PX)

26/4.5 On the assumption that no antenna gain is involved, the transmitter powers specified in No. 26/4.4 above will result in a mean effective radiated power of 1 kW (for the aeronautical stations) and 50 W (for the aircraft stations), used as the basis for the establishment of the Plan contained in Part III of this Appendix.

### PART III – Arrangement for the allotment of frequencies for the aeronautical mobile (OR) service in the exclusive bands between 3 025 and 18 030 kHz

#### 26/5.1 Column headings

Column 1: Carrier (reference) frequency, in kHz.

Column 2: Allotment area (See Notes *a*), *b*) and *c*) below).

26/5.2 Whenever the allotment area is followed by another administration's code, indicated in parentheses, the notifications are receivable from the latter administration on the basis of an agreement in accordance with Resolution 1 (Rev.WRC-97).

NOTE *a*): The allotment area is designated by the symbol of the country or the geographical area, the meaning of which is given in the Preface to the International Frequency Information Circular (BR IFIC). The meaning of the following symbol, which does not appear in the Preface to the BR IFIC, is given below: (WRC-19)

CG7 CUB(Guantanamo) (7), as defined in Appendix 26 to the Radio Regulations, Geneva, 1959; (7) means "United States of America stations"

NOTE *b*): For ease of reference, the allotment arrangement is presented by ITU Region. The symbols REG1, REG2 and REG3 correspond to the definitions of Regions 1, 2 and 3 respectively; the symbol REGY is used for the allotment area ATA (Antarctica), whose parts lie in all three Regions.

NOTE *c*): The allotment which is followed by an asterisk (\*) is subject to coordination with another administration (see Notes on the concluded operational agreements which follow the Arrangement).

1	2
3 026	REG1 ARS BEN G KAZ KGZ LIE MCO RUS REG2 ATG DMA GRD JMC KNA LCA VCT REG3 BRU KOR TON
3 029	REGY ATA(ARG) REG1 ARS AZR BLR COG E F G I IRQ KAZ MDA NOR POL RUS SEN TUN UKR UZB REG2 ALS ARG B BER(USA) CLM HWA USA REG3 AUS CHN GUM IND J KOR MHL(USA) NZL PNG VTN
3 032	REGY ATA(ARG) REG1 ALG AZR BLR COG CTI E EGY F HNG IRQ KAZ MDA MDG MLT MRC NOR OMA POL RUS SEN TUN UKR UZB REG2 ALS ARG B BER(USA) CAN CLM DOM GRL HWA SLV USA REG3 AUS CBG CHN GUM IND J J(USA) LAO MHL(USA) NZL PNG VTN VUT
3 035	REGY ATA(ARG) REG1 ARM ARS BFA BHR(USA) BLR COG F G G(USA) GEO HRV I(USA) ISL KAZ KGZ LVA MLT MRC NOR RUS SEN TCD TJK TKM TUN TUR REG2 ALS ARG B BER(USA) BRB(USA) CG7 HWA MDW PNR PTR TRD(USA) USA REG3 AUS CHN GUM IND INS J(USA) NZL PNG
3 038	REGY ATA(ARG) REG1 ARM ARS BFA BHR(USA) BLR COG CTI CYP(G) EGY F G G(USA) GEO GRC HRV I(USA) ISL KAZ KGZ LVA MDG MNE MRC MTN* NOR OMA REU RUS SEN SRB SVN TCD TJK TKM TUN REG2 ALS ARG ATG(USA) B BAH(USA) BER(USA) BRB(USA) CAN CG7 GRL HWA MDW MRT NCG PNR PTR TCA(USA) TRD(USA) USA REG3 AUS CBG CHN GUM IND INS J(USA) LAO MHL(USA) NCL NZL OCE PNG VTN VUT
3 041	REG1 ALG G I ISL KWT NMB RUS TJK REG3 HKG IRN KRE PHL TUV
3 044	REGY ATA(ARG) REG1 AFS ALG CME COG CZE DJI(F) F G GAB I ISR KAZ LRU MDA MDG MLI* MTN POR ROU RUS SEN* TCD TJK TKM UKR REG2 ARG CAN CLM JON MEX REG3 AUS BGD CHN GUM IRN J NCL NZL OCE PAK PNG
3 047	REGY ATA(ARG) REG1 AFS ALG AZE BLR CME COG CTI CZE DJI(F) E F GAB IRL ISL ISR KAZ LRU MDA MDG MLI* MLT MTN NIG POR RUS SEN* TCD TKM TUR UKR REG2 ARG CAN CLM CTR HTI HWA JON MEX REG3 AUS BGD CBG CHN FJI GUM INS J(USA) LAO NCL NZL OCE PNG VTN VUT
3 050	REGY ATA(ARG) REG1 AZE AZR BLR CME COG DNK F G GIB I KAZ MDG MLI MLT MRC POR REU RUS SEN* TCD TJK UKR UZB REG2 ALS ARG B BER(USA) CAN CUB HWA MDW PNR PTR USA REG3 AUS CHN DGA(USA) FJI GUM IND IRN J(USA) MHL(USA) NZL PAK PNG
3 053	REGY ATA(ARG) REG1 ALB AZR CME COG CTI DNK F G GIB HNG KAZ MDG MLI MRC POR RUS SEN* TCD TJK UKR UZB REG2 ALS ARG B BER(USA) BES CAN CUB CUW GTM HWA MDW PNR PTR SXM USA REG3 AUS CHN FJI GUM IND INS IRN J(USA) MHL(USA) NZL PNG VTN
3 056	REG1 BLR COG D EST F G GAB GIB KAZ MDG MLI ROU RUS SEN* TCD TJK UAE UKR UZB REG2 B BES CAN CUW HWA JON MEX MRT SXM USA REG3 AUS GUM IND INS J(USA) KOR PNG

1	2
3 059	REG1 AZR BLR COG CTI D E F G GAB GRC I KAZ MDG MLI REU ROU RUS SEN* SYR TCD TKM UKR UZB REG2 B CAN CHL HWA JON MEX MRT USA REG3 AUS IND INS J J(USA) KOR NZL PNG VTN
3 062	REG1 G GUI I ROU RUS SSD SWZ TKM REG3 IRN J
3 065	REGY ATA(ARG) REG1 ARM AZE AZR D F G JOR LVA POR ROU RUS S TJK TKM UKR REG2 ALS ARG B BER(USA) CUB GRL HWA JON PNR USA REG3 AUS GUM IND IRN J MHL(USA) PNG
3 068	REGY ATA(ARG) REG1 ARM AZE AZR ERI ETH F G HOL ISL LTU LVA MNE POR RUS S SRB SYR TJK TKM UAE UKR REG2 ALS ARG B BER(USA) CAN CG7 CUB HWA JON PNR PRU USA REG3 AUS CBG GUM INS J(USA) LAO MHL(USA) PNG VTN
3 071	REGY ATA(ARG) REG1 AGL AZE BUL DJI(F) F G GRC HOL I ISL KAZ KGZ LTU LVA MOZ POR REU RUS STP TKM TUN UKR UZB REG2 ALS ARG B BER(USA) CLM JON MDW USA REG3 AUS BGD CHN HKG J MHL(USA) PAK PNG
3 074	REGY ATA(ARG) REG1 AGL AZE AZR BUL CPV EGY F G GIB GRC HNG I KAZ KGZ LVA MLT MOZ NIG POR RUS S STP TUN UKR UZB REG2 ALS ARG B BER(USA) CAN CLM GRL GTM HTI JON MDW USA REG3 AUS BGD CHN CLN GUM HKG J MHL(USA) MLA PAK PNG SNG*
3 077	REGY ATA(ARG) REG1 ARS AZR CYP(G) D F G GRC KGZ LVA MLT POR RUS UKR REG2 ALS ARG B CAN HWA PRG URG USA VEN REG3 AUS CHN HKG J KOR NZL PNG SNG
3 080	REGY ATA(ARG) REG1 ARS AZR CYP(G) D EGY F FIN G GIB KEN KGZ LBY LVA MLT POR ROU RUS SOM TUR UKR REG2 ALS ARG B CAN CUB HWA PRG PRU SLV URG USA VEN REG3 AUS CHN CLN FJI GUM HKG IND J J(USA) KOR MLA* NZL PNG SNG
3 083	REG1 CYP(G) G GMB GRC I KGZ QAT RUS REG3 HKG J MLD
3 086	REG1 AFS BLR CYP(G) D F G GRC KAZ KGZ MDA OMA ROU RUS SVK UKR UZB REG2 ALS B BER(USA) CAN CG7 CHL HWA MDW PNR PTR USA REG3 AUS BRM CHN GUM J(USA) MHL(USA) PNG
3 089	REGY ATA(USA) REG1 ALG AZE BLR D EGY G GRC GRC(USA) II(USA) KAZ MDA MRC POR ROU RUS SEY SUI SVK UAE UKR UZB REG2 ALS B BER(USA) CG7 CHL GRL HWA MDW PNR PTR USA REG3 AUS CHN GUM J(USA) MHL(USA) PNG
3 092	REGY ATA(ARG) REG1 ALG ARS AZE AZR DJI(F) F G GEO GIB ISL KAZ POL REU RUS TJK TKM UZB REG2 ALS ARG B BER(USA) CAN CG7 DOM HWA MDW MEX PNR PTR USA REG3 AUS BGD CHN GUM J MHL(USA) NZL PNG

1	2
3 095	REGY ATA(ARG) REG1 ALG ARS CYP(G) E EGY F G GEO GIB GRG(USA) I ISR KAZ KEN LBY MLT POL RUS SOM TJK TKM UZB ZWE REG2 ALS ARG B CAN CG7 CTR DOM HWA MDW MEX PNR PRU PTR USA REG3 AUS BGD CHN CLN FJI GUM HKG J MHL(USA) MLA NZL PNG SNG*
3 098	REG1 ALB AZE AZR BHR(USA) BLR CNR E G GEO GIB I I(USA) KAZ NIG RUS TJK UKR REG2 ALS ATG(USA) B BAH(USA) BER(USA) BRB(USA) CHL HWA MDW MRT PNR PTR TCA(USA) TRD(USA) USA REG3 AUS BGD GUM HKG J MHL(USA) PAK PNG
3 101	REG1 AFS ALB AZE AZR BHR(USA) BLR CNR D E EGY ERI ETH G GEO GIB GRG(USA) HNG I I(USA) ISL KAZ LBY MLT RUS SUI TJK TUN UKR REG2 ALS B BER(USA) BRB(USA) CAN CHL GRL HND HWA MDW MRT PNR PTR TRD(USA) USA REG3 AUS BGD CHN CLN GUM HKG J MHL(USA) MLA PAK PNG SNG*
3 104	REG1 E GEO GIB I IRL ISL RUS SDN TUN UAE UKR REG2 ALS REG3 J NPL
3 107	REG1 CNR D E F G GRG(USA) I KAZ LTU MDA MNG RUS S UKR ZMB REG2 ALS B BER(USA) CG7 CHL HWA MDW PNR PTR USA REG3 AUS BRM CHN GUM IND INS J MHL(USA) PAK PNG
3 110	REG1 AFS ALB AZR CNR D E EGY G GRG(USA) I ISL KAZ LTU MDA MNG MRC NIG RUS S TJK TUR UKR UZB REG2 ALS B BER(USA) CAN CG7 CHL GRL HWA MDW PNR PTR USA REG3 AUS CHN DGA(USA) GUM IND INS J(USA) MHL(USA) PAK PNG
3 113	REG1 ALB ALG AZE BLR E F G G(USA) GRG ISL KAZ KEN KGZ MDA RUS SVK TJK TKM TUN UKR UZB REG2 B CAN CHL DOM MEX USA VEN REG3 AUS CHN GUM HKG J(USA) PAK PNG SNG
3 116	REG1 AFS ALG AZE BLR D EGY G GIB I ISL KAZ KGZ MDA MLT MNG RUS SVK TJK TKM TUN UKR UZB REG2 B CAN CHL CTR DOM EQA MEX USA VEN REG3 AUS CHN CLN HKG IND J J(USA) MLA NZL PAK PNG SNG*
3 119	REGY ATA(ARG) REG1 ALB BLR DJI F G GRG(USA) HOL I I(USA) KAZ MRC ROU RUS SVN UKR UZB REG2 ALS ARG B BER(USA) HWA MDW PNR PTR USA REG3 AUS BGD CHN FJI GUM IND INS J KIR MHL(USA) PNG
3 122	REGY ATA(ARG) REG1 AZR BLR E EGY F G GEO GRG(USA) HOL I I(USA) KAZ MRC ROU RUS TUR UKR REG2 ALS ARG B BER(USA) BOL CAN GRL HWA MDW PNR PTR USA REG3 AUS BGD CHN FJI GUM INS J KIR MHL(USA) NZL PAK PNG
3 125	REG1 BLR CYP(G) G GEO HOL KAZ LBR MLT MNG MWI ROU RUS SMR REG2 BLZ REG3 J PAK SMO
3 128	REG1 BEL BLR G GRG HNG HOL I KAZ LVA NIG ROU RUS UKR REG2 ALS BES CAN CUB CUW HWA MDW PNR PTR SXM URG USA REG3 AUS CHN FJI GUM HKG IND INS J MHL(USA) NCL NZL OCE PAK PNG
3 131	REG1 BEL EGY G GRG HOL I LSO LVA MNG RUS SRL TKM UKR REG2 ALS BES BOL CAN CHL CUB CUW EQA GTM HWA MDW PNR PTR SUR SXM URG USA REG3 AUS CHN CKH FJI GUM IND INS J MHL(USA) NCL NZL OCE PAK PNG VUT



1	2
3 134	REG1 ARM ARS(USA) AZE AZR BUL D(USA) E G HOL I KAZ LVA OMA RUS TJK TKM TUR(USA) UKR UZB REG2 ALS B BER(USA) DOM HWA JON PRG USA VEN REG3 AUS CHN GUM IND J MHL(USA) PNG TLS
3 137	REG1 ARM ARS(USA) AZE AZR BHR BUL D(USA) E EGY F G G(USA) I ISL KAZ LVA MDA MNG MRC NIG RUS TJK TKM TUR(USA) UKR UZB REG2 ALS B BER(USA) CAN CHL DOM EQA GRL GTM HWA JON PRG SUR USA VEN REG3 AUS CHN GUM IND J(USA) MHL(USA) PHL(USA) PNG TLS
3 140	REGY ATA(ARG) REG1 ALG AZE CME COG D F G GAB GEO GRC I KAZ LVA MDA MDG MKD MLI ROU RUS SEN* TCD TJK UKR REG2 ALS ARG B BER(USA) GRL HWA JON PNR USA REG3 AUS CHN GUM J J(USA) MHL(USA) PNG
3 143	REGY ATA(ARG) REG1 ALG AZE BIH CME COG CTI CYP(G) D EGY F G GAB GEO GIB GRC HRV KAZ KGZ LVA MDG MKD MLI* MLT MNE MRC ROU RUS SEN SRB SVN TCD TJK TUN UKR REG2 ALS ARG B BER(USA) CAN GRL HWA JON PNR USA REG3 AUS BRM CHN GUM J J(USA) MHL(USA) PNG
3 146	REG1 AZE BEL COM CYP G GHA I KGZ MLT MNG RUS REG2 BAH REG3 J NRU PAK
3 149	REG1 AGL ALG AZE BLR BUL CME COG D D(F) EST G GAB GHA GRC I KAZ MDG MLI* MLT MTN ROU RUS SEN* TCD TUN UKR REG2 ALS CAN DOM HWA MDW MEX PNR PTR USA REG3 AUS BRM CHN GUM INS J PAK PNG WAK
3 152	REG1 ALG BLR BUL CME COG CTI D D(F) EGY G GAB KAZ MDG MLI* MRC NIG ROU RUS SEN TCD TUN UAE UKR REG2 ALS ARG B BOL CAN CHL CLM DOM EQA HWA MDW MEX PNR PRG PRU PTR SUR URG USA VEN REG3 AUS CHN GUM INS J NZL PNG WAK
3 900	REG1 ALG BIH CME COG CZE D E F G ISL KAZ KGZ LTU MDA MDG MLI* OMA RUS SEN TCD TJK TKM TUN TUR UKR
3 903	REG1 AFS ALG CME COG CTI CZE D EGY F G HRV ISL KAZ KGZ LTU MDA MDG MLI MNE MRC REU RUS SEN* SRB SVN TCD TJK TKM TUN TZA UGA UKR
3 906	REG1 ALB AZE BEL GMB HOL HRV IRL KAZ MLT NIG RUS TZA UGA UKR YEM
3 909	REG1 AZE BLR COG DJI(F) E F G GIB HRV KAZ LVA MDG REU RUS SEN TCD UKR UZB
3 912	REG1 BLR COG CTI EGY F G GIB HRV KAZ LVA MDG MNE MRC RUS SEN SRB SVN TCD UKR UZB
3 915	REG1 ALB ALG BLR COM CZE F G GRC KAZ LTU LVA MNG ROU RUS SSD SVK TJK TKM UKR UZB YEM
3 918	REG1 AFS ALB ALG BLR CZE EGY ERI ETH F G I KAZ LTU LVA MRC NIG ROU RUS SVK TJK TKM UKR UZB
3 921	REG1 ALG DJI F G GRC KWT LVA MLT POR ROU RUS UKR UZB ZMB
3 924	REG1 AZR BEN CYP(G) D EGY F G GEO GIB GRC LSO LVA MLT POR ROU RUS SEY UAE UKR
3 927	REG1 BUL GEO GIB HOL IRL LBR LIE MWI RUS SDN TUR
3 930	REG1 AFS ALG BUL CAF CME CYP(G) DJI(F) G GIB GRC HOL LVA MDG MLI MLT ROU RUS SMR SVK TUN UKR
3 933	REG1 ALG AUT CAF CME CTI CYP(G) D DJI(F) E F G GIB GRC I KAZ LVA MDG MLI MLT MRC QAT ROU RUS SVK TUN UKR
3 936	REG1 AFS AZE BEL CNR E G I KAZ NIG POL RUS TJK TUR UZB YEM

1	2
3 939	REG1 AFS AZE CNR CYP(G) D E F G GRC I KAZ MLT POL RUS TJK TUN UZB YEM
3 942	REG1 CYP CZE F G GIB ISL KAZ LVA NOR POL RUS SRL SWZ UKR UZB YEM
3 945	REG1 AFS ALG CZE ERI ETH F G GIB GRC ISL KAZ LVA MRC NOR POL RUS SEN UKR UZB
4 700	REG1 ARM ARS AZE BEN BHR(USA) CYP(G) G GIB I KAZ KEN LBY MLT POL RUS SEY SWZ TJK TKM REG2 ALS B CAN DOM HWA MDW MEX PNR PTR USA REG3 AUS BGD BRM CHN DGA(USA) FJI GUM HKG IND J(USA) KOR MAC MHL(USA) NZL PAK PNG TLS
4 703	REG1 AFS ALG ARM ARS AZE AZR BHR(USA) CYP(G) DNK E EGY F G GEO GIB I KAZ KEN LBY MLT MRC POL RUS SOM TJK TKM TUR REG2 ALS B CAN CHL DOM HWA MDW MEX PNR PTR SUR USA REG3 AUS BGD BRM CHN CLN FJI GUM HKG IND J J(USA) KOR MAC MHL(USA) MLA NZL PAK PNG TLS
4 706	REGY ATA(USA) REG1 ALG BLR CYP(G) D F G GEO HRV I I(USA) KAZ KEN KGZ LBY LSO LTU MDA MLT RUS TJK TKM TUR UKR YEM REG2 ALS B BER(USA) CAN CG7 HWA MDW PAQ PNR PRG PTR URG USA REG3 AUS CHN DGA(USA) GUM IND J(USA) MHL(USA) NZL SNG THA
4 709	REG1 AFS ALG ARS BLR CYP(G) D F G GRC I I(USA) KAZ KEN KGZ LBR LBY LTU MDA MLT MNE OMA RUS SRB TJK TKM TUR UKR REG2 ALS B BER(USA) CG7 CHL HWA MDW PAQ PNR PRG PTR URG USA REG3 AUS CHN GUM IND INS J MHL(USA) NZL THA
4 712	REGY ATA(USA) REG1 AZR BLR CYP(G) EGY F GIB I(USA) IRL ISL KAZ MLT MRC MWI POL ROU RUS SOM SRL SSD UKR YEM REG2 ALS BER(USA) CAN CG7 GRL HWA MDW PNR PRU PTR USA REG3 AUS CBG FJI GUM J(USA) KRE LAO MHL(USA) NPL PHL PNG VTN
4 715	REGY ATA(ARG) ATA(USA) REG1 AGL ALB AZR BHR(USA) BLR CME DJI(F) F G GMB GRC HOL I ISL ISR KAZ LTU MDA MNG MOZ POL POR RUS STP TCD TUN TUR UKR UZB REG2 ALS ARG ATG(USA) BAH(USA) BER(USA) BES BRB(USA) CAN CLM CUW HWA MDW PNR PTR SXM TCA(USA) TRD(USA) USA REG3 AUS BGD BRM FJI GUM HKG IND J(USA) MHL(USA) MLA PAK THA
4 718	REGY ATA(ARG) ATA(USA) REG1 AGL ALB ALG AZR BHR(USA) CME CPV DJI(F) F G HOL I ISL ISR KAZ KGZ LTU MDA MDG MLT MOZ POR RUS STP TCD TUN UKR UZB REG2 ALS ARG BER(USA) BES BRB(USA) CAN CLM CUW GRL HWA MDW PNR PRU PTR SXM TRD(USA) USA REG3 AUS BGD BRM CLN FJI GUM HKG IND J(USA) MHL(USA) MLA NZL PAK PNG SNG* THA
4 721	REGY ATA(ARG) REG1 AGL ALG BLR CME CNR D D(USA) DJI(F) E F G GEO I KAZ KGZ MLT MOZ POR ROU RUS STP TCD TJK TUR(USA) UKR REG2 ALS ARG BER(USA) CAN CUB GRL HWA JON PNR PRU USA REG3 AUS BGD CHN GUM IND J(USA) MHL(USA) NCL NZL OCE PAK PNG THA TLS

1	2
4 724	REGY ATA(ARG) REG1 AGL ALG AZR BEL BLR CME CNR CPV D D(USA) DJI(F) E EGY EST F G G(USA) GEO HNG I KAZ MDG MOZ POR REU RUS STP TCD TJK TUR(USA) UAE UKR REG2 ALS ARG BER(USA) CAN CG7 CUB GRL HWA JON PNR USA REG3 AUS BGD CBG CHN GUM IND INS J(USA) LAO MHL(USA) NCL NZL OCE PAK PHL(USA) PNG THA TLS VTN VUT
4 727	REG1 AZE BEL BUL COG CYP(G) CZE DJI(F) F G GEO KAZ LVA MDG QAT ROU RUS SEN TCD TJK TUN TUR UKR REG2 ALS BER(USA) CAN CUB FLK GRL HWA JON URG USA REG3 AUS BRM CHN GUM IND J MHL(USA) THA TON
4 730	REG1 AFS AZE BUL COG CTI CYP(G) CZE F G GEO I KAZ LVA MDG MNG ROU RUS SEN TJK TUN UKR YEM REG2 ALS ATG BER(USA) CAN CUB DMA EQA FLK GRD GRL HWA JMC JON KNA LCA URG USA VCT REG3 AUS BRM CHN GUM IND INS J(USA) MHL(USA) NZL THA
4 733	REG1 ALG BDI BEL COM DJI E G GUI KWT LBN LIE MLT MRC NMB RUS S SDN SMR TKM UAE REG2 BAH HND HWA NCG PRU USA REG3 AUS BTN GUM J MLD NRU SMO VUT
4 736	REGY ATA(ARG) REG1 AFS ALB ALG ARS AUT AZE AZR BLR BUL COG D DJI(F) E ERI ETH F GRC I IRL KAZ LBN MDG MLI MRC NOR OMA POR REU RUS SEN* TCD TJK TKM UKR UZB REG2 ALS ARG B BER(USA) CAN CG7 HND HWA JON MDW MEX MRT PNR PTR USA REG3 AUS CHN GUM IND J MHL(USA) NZL THA TUV WAK
4 739	REGY ATA(ARG) REG1 ALB ALG ARS AUT AZE AZR BLR COG CTI D EGY F G GIB I ISL KAZ LBN MDG MLI NOR POR ROU RUS SEN* TCD TJK TKM UKR UZB REG2 ALS ARG B BOL CAN CG7 HWA JON MDW MRT PNR PTR USA REG3 AUS CHN FJI GUM IND J MHL(USA) MLA* NZL PAK PNG SNG THA WAK
4 742	REG1 ALG CME COG CYP DJI(F) F G GEO GIB I KAZ MDG MKD MLI MNG POL POR REU RUS SEN* TCD TGO TUN UZB YEM REG2 ALS BER(USA) CAN CHL GRL HND HWA JON PRG URG USA VEN REG3 AUS BRU CHN FJI GUM HKG IND IRN J J(USA) KOR MHL(USA) PAK PNG
4 745	REG1 AZR BEL CME COG CTI D DJI(F) EGY F G GEO I ISL KAZ MDG MLI* MRC POL POR REU RUS SEN SUI TCD TGO TUN TUR UZB YEM ZMB REG2 ALS BER(USA) CAN CHL GRL HND HWA JON PRG URG USA VEN REG3 AUS CBG CHN FJI GUM IND IRN J(USA) KOR LAO MHL(USA) NZL PNG VTN
5 684	REGY ATA(ARG) REG1 AGL ALB AZE AZR BLR CPV CYP D F G GEO I KAZ KWT LVA MOZ POR RUS SRL STP TJK TKM UKR UZB YEM REG2 ARG BES CAN CUW MEX PRG SXM USA REG3 AUS CHN GUM HKG IND J(USA) KOR SMO THA VTN
5 687	REGY ATA(ARG) REG1 AFS AGL ALB AZE AZR BLR CPV D E EGY G GEO GIB HRV I KAZ LVA MNE MOZ NIG OMA POR RUS SRB STP SVN TJK TKM UKR UZB REG2 ARG BES CAN CUW EQA MEX PRG SXM USA REG3 AUS CHN GUM IND INS IRN J KOR NZL PNG THA VUT
5 690	REG1 BDI DJI E GMB GNE GRC HOL I IRL ROU RUS SWZ TUR UAE REG2 HTI REG3 CHN IRN J TON

1	2
5 693	REGY ATA(ARG) REG1 AFS ARS AZR CME COG CYP(G) F G GIB I IRQ ISL ISR KAZ LVA MLI MRC ROU RUS SVK TUN TUR UKR YEM REG2 ALS ARG ATG(USA) BAH(USA) BER(USA) BRB(USA) CAN CG7 HWA MDW PNR PTR TCA(USA) TRD(USA) USA VEN REG3 AUS BGD BRM GUM HKG J J(USA) MLA NZL PAK PNG THA
5 696	REGY ATA(ARG) REG1 ARS BEL CME COG CTI CYP(G) EGY G GIB GRC(USA) IRQ ISL KAZ KEN LBY LVA MCO MDG MLI MLT OMA ROU RUS SOM SVK TUR UKR REG2 ALS ARG BER(USA) BOL BRB(USA) CAN CG7 GRL GTM HWA MDW MEX PNR PTR TRD(USA) USA VEN REG3 AUS BGD BRM CLN FJI GUM J(USA) NZL PAK SNG THA
5 699	REGY ATA(ARG) REG1 ALG AZR BFA BLR CME DJI(F) F G GAB KAZ LTU LVA MDA MLI MNE MWI RUS SRB TCD TUR UKR REG2 ALS ARG CAN GRL GTM HWA MEX PTR USA REG3 AUS BRM CHN GUM IND IRN J MAC MHL(USA) NZL PAK THA VTN
5 702	REGY ATA(ARG) REG1 ALG AZR BFA BLR CME CTI DJI(F) E EGY ERI ETH F G G(USA) GAB GRC HOL KAZ LSO LTU LVA MDA MDG MLI* MNE MRC MTN OMA POR REU ROU RUS SEN* SRB TCD TJK UKR UZB REG2 ALS ARG BOL CAN CLM GRL MEX USA REG3 AUS BRM CHN FJI IND INS IRN J(USA) MAC NZL PNG THA
5 705	REG1 BEN CYP(G) ERI ETH F G GIB GRC HOL KAZ MLT QAT ROU RUS TJK UAE UKR UZB ZMB REG2 ATG B BLZ DMA GRD JMC KNA LCA VCT REG3 BRU HKG J MLD NPL NRU
5 708	REG1 AFS AGL COG F GRC HNG IRL IRQ KAZ KGZ LBN MTN* NOR OMA POL ROU RUS SEN SEY SYR TJK TKM TUN TUR YEM REG2 ALS B BER(USA) BOL CAN CHL CLM GRL HWA MDW USA REG3 AUS BRM CHN IND J KOR MHL(USA) NZL PNG SNG THA TLS
5 711	REG1 AGL COG CTI F G GIB GRC IRQ ISL KAZ KGZ LBN MDG MRC MTN* NOR POL RUS SEN SYR TJK TKM TUN TUR UAE UKR YEM REG2 ALS B BER(USA) BOL CAN CHL CLM GRL HWA MDW USA REG3 AUS BRM CHN IND J(USA) KOR MHL(USA) MLA NZL PNG THA TLS
5 714	REGY ATA(USA) REG1 AFS ARM AUT AZE BLR BOT BUL CME CTI CYP(G) D D(F) DJI(F) F G GIB HRV I KAZ MLI MLT MNG NMB(AFS) REU ROU RUS TCD TGO TJK TKM TUN UKR UZB REG2 ALS B CAN CUB HWA MDW PNR PTR USA REG3 AUS CHN DGA(USA) FJI GUM J(USA) MHL(USA) NZL PAK THA
5 717	REGY ATA(USA) REG1 AFS ARM AUT AZE AZR BLR BOT BUL CME CTI CYP(G) D D(F) DJI(F) E EGY EST ERI ETH F G GRC KAZ MDG MLI MLT MRC NMB(AFS) OMA REU ROU RUS SEN* TCD TGO TJK TKM TUN UKR UZB REG2 ALS B BOL CAN CHL CUB GTM HWA MDW MEX PNR PTR USA REG3 AUS CBG CHN DGA(USA) FJI GUM J(USA) LAO MHL(USA) NZL PAK PNG THA VTN
5 720	REG1 ALG BEL COM CYP(G) G GIB ISL LBR LIE MLT NMB OMA ROU RUS SMR SSD TKM UAE REG2 BAH BOL GTM REG3 HKG IND J KRE PHL TUV

1	2
5 723	REGY ATA(USA) REG1 AFS ALG AZE BHR(USA) BLR COG F G GRC(USA) HNG I ISL KAZ LVA MRC MTN NMB(AFS) POR RUS SEN* SOM SVK TKM UAE UKR REG2 ALS ATG(USA) B BER(USA) BRB BRB(USA) CAN CG7 CHL HND HWA MDW PNR PTR TCA(USA) URG USA REG3 AUS CHN GUM IND J J(USA) KOR MHL(USA) NCL OCE PNG THA
5 726	REGY ATA(USA) REG1 AFS ALG AZE AZR BHR(USA) BLR COG CTI EGY F G GIB I ISL KAZ LVA MDG MTN NMB(AFS) POR ROU RUS S SEN* SVK TKM UKR YEM REG2 ALS ATG(USA) B BAH(USA) BER(USA) BRB CAN CG7 CHL GRL HND HWA MDW PNR PTR TCA(USA) URG USA REG3 AUS CBG CHN GUM IND J J(USA) KOR LAO MHL(USA) NCL NZL OCE THA VTN VUT
6 685	REG1 AFS AGL ALB ARS AZE BHR(USA) CPV D EGY G GEO GNB GRC(USA) I I(USA) ISL KAZ MOZ MNE MRC NIG NOR POR RUS SRB STP SUI SVK TJK TUR UZB REG2 ALS B BER(USA) CAN CG7 DOM EQA HWA MDW MEX PNR PTR URG USA REG3 AUS CBG CHN CLN GUM HKG IND J LAO MHL(USA) MLA PAK PNG SNG* VTN
6 688	REG1 ALB ALG AZR EGY F FIN G GRC(USA) HRV I I(USA) ISL MLT MRC RUS SVK TJK TUN YEM ZMB REG2 ALS CG7 DOM HWA MDW NCG PNR PTR USA REG3 AFG AUS BGD FJI GUM J KRE MHL(USA) PAK VUT
6 691	REGY ATA(ARG) REG1 ALG ARS AZR BUL CYP(G) CZE E G GHA GIB HNG I I(USA) KAZ KEN LBY MLT ROU RUS TJK TKM UZB REG2 ALS ARG CAN CLM HWA MDW MEX PNR PTR USA REG3 AUS BGD BRM CHN GUM HKG IND J J(USA) KOR PAK SLM SNG WAK
6 694	REGY ATA(ARG) REG1 ALG ARS AZR BLR BUL CYP(G) CZE EGY ERI ETH G GIB I I(USA) KAZ KEN LBY NIG OMA ROU RUS SOM TKM UZB REG2 ALS ARG CAN HWA MDW MEX PNR PTR USA REG3 AUS BRM CHN CLN FJI GUM HKG IND J(USA) KOR MLA NZL PNG SNG* WAK
6 697	REGY ATA(ARG) REG1 ARS BDI BHR(USA) BLR CYP(G) D G I I(USA) ISL MLT MRC RUS SMR REG2 ALS ARG BER(USA) CAN CG7 HWA MDW PNR PTR TRD USA REG3 AUS BGD GUM HKG J(USA) PAK THA
6 700	REGY ATA(ARG) REG1 ARS AZR BHR(USA) CYP(G) D EGY F G GIB GRC I I(USA) ISL KEN LBY MLT MRC RUS SOM TUR REG2 ALS ARG ATG(USA) BAH(USA) BER(USA) BRB CAN CG7 GRL HWA MDW PNR PTR TCA(USA) TRD USA REG3 AUS BGD CLN GUM HKG J(USA) MHL(USA) MLA NZL PAK PNG SNG* THA
6 703	REG1 ALB BEN ERI ETH I IRL ISL LUX NMB QAT RUS SEY SVN UKR REG2 HTI REG3 J MLD NPL PHL SMO
6 706	REG1 AFS BLR CYP(G) EGY G GIB GNE GRC KAZ MDA MLT MNE RUS SRB SVK UKR UZB YEM REG2 ALS B CAN CUB HWA MDW PNR PTR USA REG3 AUS BGD CHN DGA(USA) FJI GUM HKG IND INS J KIR MAC MHL(USA) NZL PAK THA

1	2
6 709	REG1 BEL BIH BLR CYP(G) G GEO HRV KAZ KEN LBY LSO MDA MLT MNE ROU RUS SOM SRB SVN UKR UZB REG2 ALS B CAN CUB HWA MDW PNR PTR SUR USA REG3 AUS BGD CHN CLN FJI GUM HKG IND INS J KIR MAC MHL(USA) NZL PAK PNG THA VTN
6 712	REG1 AFS ALG AUT AZE BLR CME COG CYP(G) D D(F) DJI(F) F G GEO ISL ISR KAZ LVA MDG MLI* MLT MTN OMA REU ROU RUS SEN* TCD TGO TJK TKM TUN TUR TUR(USA) UKR UZB REG2 B CAN HWA MEX PNR USA REG3 AUS BRM CHN IND J(USA) KOR PAK THA TLS VTN
6 715	REG1 AFS ALG AUT AZE BLR CME COG CTI D D(F) DJI(F) E F G G(USA) HNG ISR KAZ LVA MDG MLI MRC MTN* REU ROU RUS SEN* TCD TGO TJK TKM TUN TUR(USA) UAE UKR UZB REG2 B CAN GRL HWA MEX PNR SUR USA REG3 AUS BRM CHN FJI GUM IND INS J(USA) KOR NZL PAK PHL(USA) PNG THA TLS
6 718	REG1 AGL ALG CYP F HOL IRL MLT NIG ROU TUR TZA UZB YEM REG2 BAH REG3 IND NRU PAK
6 721	REGY ATA(ARG) ATA(USA) REG1 AGL ARS AZR BHR(USA) F G GEO GRG(USA) HOL I I(USA) JOR KAZ LTU MDA MRC RUS SRL TJK TZA UKR UZB REG2 ALS ARG BER(USA) CAN CG7 HWA MDW MEX PNR PTR USA REG3 AUS CHN FJI GUM IND J(USA) MHL(USA) NZL SNG THA
6 724	REGY ATA(ARG) ATA(USA) REG1 AFS ARS BHR(USA) CNR E EGY G GEO GRG(USA) HRV I I(USA) KAZ LBR LTU MDA MNE MRC RUS SRB SVN TJK UKR UZB REG2 ALS ARG BER(USA) CG7 GRL HWA MDW MEX PNR PTR SUR USA REG3 AUS CHN FJI GUM IND J(USA) MHL(USA) MLA* NZL PNG SNG THA
6 727	REGY ATA(ARG) REG1 AGL ALG ARS ARS(USA) AZR D(USA) ERI ETH G GRG KAZ LIE MOZ RUS STP TUR(USA) UKR UZB REG2 ALS ARG BER(USA) CAN CUB GRL GUY HWA JON MDW PNR USA REG3 AUS CHN GUM IND J MHL(USA) THA
6 730	REGY ATA(ARG) REG1 AGL ALG ARM ARS ARS(USA) AZR CPV D D(USA) DNK E ERI ETH F G GNB GRG ISL KAZ MOZ NIG POR ROU RUS STP SYR TUR(USA) UKR UZB REG2 ALS ARG BER(USA) CAN CG7 CUB GRL GUY HWA JON MDW PNR USA REG3 AUS CHN GUM IND J J(USA) MHL(USA) MLA NZL PAK PNG SNG* THA
6 733	REG1 ALG ARM F G GUI I KEN NIG RUS SWZ TUR UAE YEM REG2 B REG3 IND J TUV VTN
6 736	REG1 AFS ARM ASC(USA) AZE CYP(G) CZE G GIB GRG I ISL KEN MLT MRC NMB(AFS) OMA ROU RUS SEY(USA) TJK TKM REG2 ALS B BER(USA) CAN CHL CLM GTM HWA PNR PTR URG USA REG3 AUS BRM CHN GUM J KOR MHL(USA) PAK SNG THA VTN
6 739	REG1 AFS ARM ASC(USA) AZE CYP(G) CZE EGY F G G(USA) I MLT NMB(AFS) ROU RUS TJK TKM TUR(USA) UKR YEM REG2 ALS BER(USA) CHL CLM GRL GTM HND HWA PNR PTR SUR URG USA REG3 AUS BRM CHN CLN GUM J(USA) KOR MHL(USA) MLA NZL PAK PNG THA VTN VUT

1	2
6 742	REG1 BFA BLR CAF CME COG CYP(G) DJI(F) F FIN G GIB GRC KAZ LVA MDG MLI* NGR POL REU RUS SEN TCD TGO TUN TUR UKR REG2 ALS BER(USA) CAN CG7 CHL CUB GTM HWA JON MDW PNR PTR USA REG3 AUS CHN GUM HKG IND IRN J MHL(USA) NZL SNG THA VTN WAK
6 745	REG1 ALG ASC(USA) BFA BLR CAF CME CNR COG CTI CYP(G) CZE DJI(F) E EGY F FIN G GIB GRC HNG KAZ LVA MDG MLI MLT MRC NGR POL REU RUS SEN* SEY(USA) TCD TGO TUN UKR REG2 ALS BER(USA) BOL CAN CG7 CHL CUB GTM HWA JON MDW PNR PTR USA REG3 AUS BGD CBG CHN FJI GUM HKG IND IRN J LAO MHL(USA) NZL PNG SNG THA VTN WAK
6 748	REG1 BEL BUL CYP(G) E G GMB GRC KWT MLT POR REU RUS SDN UAE UKR ZWE REG2 ATG DMA GRD JMC KNA LCA VCT REG3 BGD BRU J TON
6 751	REG1 ASC(USA) BFA BUL CME COG COM CTI CYP(G) D DJI E F G HNG KGZ LVA MNE MTN OMA POR RUS SEN* SRB TCD TUN UAE UKR REG2 B CAN CHL HWA JON MEX USA REG3 AUS CHN FJI GUM IND INS J J(USA) MHL(USA) NZL THA VTN
6 754	REG1 ALG ASC(USA) BFA COG CTI D EGY ERI ETH F G GRC KGZ LVA MDG MRC NIG RUS SEN TCD TUN UAE UKR REG2 B BOL CAN CHL HWA JON MEX SUR USA REG3 AUS CBG FJI GUM IND INS J LAO MHL(USA) NZL THA VTN VUT
6 757	REGY ATA(ARG) REG1 ARS AZE BLR COG F G GIB KAZ KGZ LVA MLT MWI RUS SEN SVK TCD TJK TKM TUN UKR REG2 ARG BER(USA) BES BOL CUW HWA JON SXM USA REG3 AUS BRM CHN GUM IND J MHL(USA) THA TLS
6 760	REGY ATA(ARG) REG1 ALG ARS AZE BLR COG CTI F G ISL ISR KAZ KGZ LVA MDG MRC RUS SEN SVK TCD TJK TKM TUN UKR REG2 ALS ARG BER(USA) BES CUW HWA JON SXM USA REG3 AUS BRM CHN GUM IND J J(USA) MHL(USA) MLA NZL PNG SNG* THA TLS
8 965	REG1 AFS ASC(USA) CTI CYP(G) D EGY ERI ETH G GIB KEN NMB(AFS) RUS SMR TUR REG2 ALS B CAN GRL HWA MEX PNR USA REG3 AUS BRM FJI HKG J(USA) KRE MHL(USA) NZL PAK PNG
8 968	REG1 AFS ARS CYP(G) D G GIB HRV KEN LBY MLT MNE NIG NMB(AFS) OMA RUS SOM SRB SVN REG2 ALS B BOL CAN GRL HWA MEX PNR USA REG3 AUS BRM CLN FJI HKG INS J(USA) MHL(USA) MLA NZL PNG SNG*
8 971	REGY ATA(ARG) REG1 ARS AZE AZR BHR(USA) BLR E F G GEO GRC(USA) HOL HRV I I(USA) ISL ISR KAZ KGZ LVA MRC RUS S TJK TKM UKR ZMB REG2 ALS ARG ATG(USA) BAH(USA) BER(USA) BES BOL BRB(USA) CG7 CUW DOM HWA MDW PNR PTR SXM TCA(USA) TRD(USA) USA REG3 AUS BRM CHN DGA(USA) GUM J(USA) MHL(USA) PNG VTN
8 974	REGY ATA(ARG) REG1 AFS AZE AZR BLR E GEO GNE GRC(USA) HOL I I(USA) IRL ISL ISR KAZ KGZ LVA MRC RUS TJK TKM UKR YEM REG2 ALS ARG ATG(USA) BAH(USA) BER(USA) BES BRB(USA) CG7 CUW DOM HWA MDW PNR PTR SXM TCA(USA) USA REG3 AUS BRM CHN GUM J(USA) MHL(USA) NZL PNG VTN

1	2
8 977	REG1 ALB ARS BHR(USA) G GRC(USA) I ISL MRC MWI OMA RUS UKR REG2 ALS BRB(USA) HWA MDW PNR PTR TRD(USA) USA REG3 AUS CBG CLN DGA(USA) GUM INS J(USA) LAO
8 980	REGY ATA(ARG) REG1 ALB ALG ARS AZR BFA BHR(USA) CME COG CYP(G) D DJI(F) F G I KAZ LBN MDG REU RUS SEN TCD TGO TUN UZB REG2 ALS ARG ATG(USA) BAH(USA) BER(USA) BRB BRB(USA) CG7 HWA MDW PNR PTR TCA(USA) USA REG3 AUS CHN GUM HKG IND INS J(USA) MHL(USA)
8 983	REGY ATA(ARG) REG1 ALG BFA BHR(USA) CME COG CYP(G) D DJI(F) F G HNG I KAZ LBN MDG MLT MNG MRC MTN OMA REU RUS SEN* TCD TGO TUN UZB REG2 ALS ARG BER(USA) BRB(USA) CG7 GRL HWA MDW PNR PTR USA REG3 AUS CBG CHN GUM IND J(USA) LAO MHL(USA) NZL PNG VTN
8 986	REG1 ALG BHR(USA) CYP(G) F G GRC KGZ MDG MLT ROU RUS TUR UKR YEM REG2 BRB(USA) CG7 REG3 J J(USA) PHL TUV
8 989	REG1 AGL BEL BLR G KAZ KGZ LVA MCO MDA MOZ POL POR ROU RUS STP UKR UZB YEM REG2 ALS BER(USA) CAN GRL HWA MEX USA REG3 AUS BRM FJI IND J J(USA) NZL
8 992	REG1 AGL ASC(USA) BLR CPV F G GNB GRC ISL KAZ LVA MDA MOZ POL POR RUS S STP SSD UKR UZB REG2 ALS BER(USA) CAN CHL HWA MEX USA REG3 AUS BRM CHN FJI GUM IND J(USA) NZL PNG
8 995	REG1 ARS AZR COM CYP(G) G GIB GRC ISL LBR MLT MNG RUS UKR YEM REG2 BLZ REG3 BRU HKG TON
8 998	REGY ATA(USA) REG1 AGL AZR BHR(USA) BLR COG F G GRC(USA) HOL ISL LVA MDG MTN NOR SEN* TUN UAE UKR REG2 ALS B BER(USA) CG7 CUB HWA MDW PNR PTR TRD(USA) USA REG3 AUS CHN GUM IND J(USA) MHL(USA) NZL
9 001	REGY ATA(USA) REG1 AGL ALG ARM BHR(USA) BLR COG CTI CYP(G) EGY F G GRC(USA) HOL I(USA) ISL JOR LVA MDG MLT MRC MTN NOR SEN* TUN UKR REG2 ALS B BER(USA) CG7 CUB HWA MDW PNR PTR TRD(USA) USA REG3 AUS CHN DGA(USA) GUM HKG IND J(USA) MHL(USA) NZL
9 004	REG1 ARM BDI BEN BLR CYP(G) IRL ISL KWT LSO LUX MLT ROU REG2 B BAH REG3 HKG IRN J MLD NRU
9 007	REG1 AZR BUL CME COG G GIB GRC GRC(USA) I(USA) ISL KAZ MDG MLT MNE REU ROU RUS SEN SRB TCD REG2 ALS B CAN HWA MDW MEX PNR PTR USA REG3 AUS BRM CHN FJI GUM INS IRN J KIR VTN WAK
9 010	REG1 ARS AZR BEL BUL CME COG CTI G KAZ LIE MDG REU RUS SEN TCD TUR REG2 ALS ARG B CAN HWA MDW MEX PNR PTR USA VEN REG3 AUS BRM FJI GUM INS IRN J KIR NZL PAK VTN WAK
9 013	REG1 AFS ARS ERI ETH G GMB GRC HRV MLT MOZ RUS UKR REG2 ARG ATG DMA GRD GTM JMC KNA LCA VCT REG3 AUS FJI IND J



1	2
9 016	REG1 AUT COG F G GIB HNG MDG RUS SEN TCD TUN TUR UKR REG2 BER(USA) CHL CUB REG3 AUS CHN FJI HKG IRN J(USA) NZL PAK SNG THA
9 019	REG1 ALG AUT CNR COG CTI E F G GIB GRC MDG MLT MRC NIG RUS SEN TCD TUN UKR REG2 ALS BER(USA) BOL CHL CUB HWA REG3 AUS CHN IRN J MLA* NZL PAK PNG SNG THA VUT
9 022	REGY ATA(ARG) REG1 AFS ALG ARM AZE AZR COG CYP(G) CZE D(USA) EGY ERI ETH F G GEO KAZ MDG MLT REU RUS SEN SOM TJK TKM UZB REG2 ARG BER(USA) CAN GRL HWA JON PNR PTR USA REG3 AUS CHN GUM HKG IND J MHL(USA) NZL
9 025	REGY ATA(ARG) ATA(NZL) REG1 AFS ALG ARM AZE AZR COG CYP(G) CZE D D(USA) E EGY G GEO GIB KAZ MDG MLT REU ROU RUS SEN TJK TKM UZB REG2 ARG BER(USA) CUB HWA JON MEX PNR PTR USA REG3 AUS CHN FJI GUM HKG IND J(USA) MHL(USA) NZL PAK PHL(USA) PNG SNG THA
9 028	REG1 COD E G G(USA) GIB GRC MLT MRC QAT ROU RUS UAE UZB REG2 ALS CAN CG7 CUB GRL HWA MEX USA REG3 AUS J MLA SMO
9 031	REGY ATA(USA) REG1 CYP(G) G G(USA) GIB GRC(USA) I I(USA) MLT MRC POL RUS SVK SWZ TUR REG2 ALS BER(USA) CAN CHL CLM HWA MDW PNR PTR URG USA REG3 AUS BGD BRM CHN GUM J MHL(USA) MLA NZL PAK TLS WAK
9 034	REGY ATA(USA) REG1 AUT DNK G G(USA) GHA GRC(USA) I I(USA) MRC NIG POL RUS SEY TUR YEM REG2 ALS BER(USA) CHL CLM EQA HWA MDW PNR PTR URG USA REG3 BGD BRM CHN GUM INS J MHL(USA) MLA NZL PAK SMO TLS WAK
9 037	REGY ATA(USA) REG1 AUT CYP DJI G I I(USA) LTU MRC NMB RUS SRL TUR UAE REG2 ALS CAN HWA MDW PNR PTR USA REG3 AUS DGA(USA) GUM J(USA) MHL(USA) NPL WAK
11 175	REG1 ASC(USA) G GRC MLT SDN TUR(USA) UAE REG2 ALS HWA USA REG3 AUS GUM J(USA)
11 178	REGY ATA(ARG) REG1 AGL G GRC MOZ NIG NOR POL POR RUS STP TUN TUR(USA) REG2 ALS ARG BES CLM CUW HWA JON SXM USA REG3 AUS CHN GUM IND INS J J(USA) MHL(USA) NZL
11 181	REGY ATA(ARG) REG1 AGL AZR CPV E EGY G GNB ISL MOZ NOR POL POR RUS STP TUR TUR(USA) REG2 ALS ARG BES CLM CUW JON SXM USA REG3 AUS CHN GUM IND INS J(USA) MHL(USA) NZL
11 184	REG1 CYP(G) E G GNE ISL MKD MLT MNG ROU TUR REG2 BLZ REG3 J MLD TON

1	2
11 187	REGY ATA(USA) REG1 ALG BEL BHR(USA) BLR CME COG DJI(F) ERI ETH F GEO GRC(USA) ISL ISR KAZ LVA MDG ROU RUS SEN TCD TJK TKM UKR UZB REG2 ALS ATG(USA) BAH(USA) BER(USA) BRB(USA) CAN CHL HWA MDW MEX PNR PTR TCA(USA) TRD(USA) USA REG3 AUS CHN DGA(USA) GUM IRN J(USA) MHL(USA)
11 190	REGY ATA(USA) REG1 ALG BHR(USA) BLR CME COG DJI(F) GEO GRC ISR KAZ LVA MDG MRC ROU RUS SEN TCD TJK TKM UKR UZB REG2 ALS ATG(USA) BAH(USA) BER(USA) BRB(USA) CAN CHL HWA MDW MEX PNR PTR TCA(USA) TRD(USA) USA REG3 AUS BRM CHN DGA(USA) GUM INS IRN J(USA) MHL(USA) NZL
11 193	REG1 CYP(G) G GRC MNG NIG RUS REG2 MEX URG REG3 IND PHL TUV
11 196	REG1 ARS BHR(USA) CYP(G) D G KEN RUS REG2 ALS ATG(USA) B BAH(USA) BER(USA) BRB(USA) CG7 HWA MDW PNR PTR TCA(USA) TRD(USA) URG USA REG3 AUS CHN GUM HKG J(USA) MHL(USA) WAK
11 199	REG1 ARS BHR(USA) CYP(G) D EGY G GIB I(USA) KEN LBY MLT MRC OMA RUS SOM REG2 ALS ATG(USA) B BAH(USA) BER(USA) BRB(USA) CG7 HWA MDW PNR PTR TCA(USA) TRD(USA) USA REG3 AUS CHN CLN GUM HKG IRN J(USA) MLA PNG SNG* WAK
11 202	REG1 BHR(USA) CYP IRL SMR TUN YEM REG2 ALS ATG(USA) BAH(USA) BER(USA) BRB(USA) CG7 HWA MDW PTR TCA(USA) TRD(USA) USA REG3 AUS GUM J(USA) WAK
11 205	REGY ATA(ARG) REG1 AZR CME COG DJI(F) F G KAZ MDG MNG REU RUS SEN TGO TUN REG2 ALS ARG CAN CUB HWA JON MDW PNR PTR USA REG3 AUS GUM J WAK
11 208	REGY ATA(ARG) REG1 ALG AZR CME COG CYP(G) DJI(F) F G GIB GRC(USA) HNG KAZ LBY MDG MRC REU RUS SEN TGO TUN TUR REG2 ALS ARG CAN CUB HWA JON MDW PNR PTR USA REG3 AUS CBG GUM IRN J LAO PNG VTN WAK
11 211	REG1 BEL E G OMA RUS SWZ TUN REG2 ALS HWA JON MDW PNR PTR REG3 GUM IRN J MHL(USA) WAK
11 214	REGY ATA(ARG) REG1 AUT COG DJI(F) F G GAB GIB ISL MDG MLT REU RUS SEN TCD TUN REG2 ALS ARG BER(USA) CAN HWA MRT USA REG3 AUS BRU NCL NPL OCE
11 217	REGY ATA(ARG) REG1 ASC(USA) AUT COG D DJI(F) F G GRC MDG MRC RUS SEN SEY(USA) TCD TUN REG2 ALS ARG BER(USA) CAN GRL HWA MRT USA REG3 AUS CHN NCL NZL OCE
11 220	REG1 BDI BEL GMB KWT ROU RUS REG2 CAN USA REG3 AUS CBG CHN J LAO VTN VUT

1	2
11 223	REG1 BEN G MLT ROU S UKR YEM REG2 ALS ATG CAN DMA GRD JMC KNA LCA VCT REG3 AUS IRN J KRE
11 226	REG1 ARS(USA) AZR D D(USA) G MNE RUS SRB SRL TUR(USA) UKR REG2 ALS BER(USA) CHL CUB GRL HWA JON MDW PNR USA REG3 AUS BGD CHN GUM J(USA) MHL(USA) NZL PAK PHL(USA)
11 229	REG1 ARS(USA) AZR D D(USA) G MNE MRC RUS SRB TUR(USA) REG2 ALS BER(USA) CAN CG7 CUB GRL HWA JON MDW PNR USA REG3 AUS BGD CHN GUM J MHL(USA) NZL PAK
11 232	REG1 HOL IRL LIE NIG QAT RUS UAE YEM REG2 BAH CAN REG3 AUS J SNG
11 235	REG1 AFS ARM AZE BLR CYP(G) D F G KAZ KGZ LVA MNG RUS SEN TJK TKM TUN UKR UZB REG2 ALS ARG BER(USA) CAN GRL HWA MEX USA REG3 AUS BRM GUM J PNG SNG
11 238	REG1 ALG ARM AZE BLR D KAZ KGZ LSO LVA MRC RUS SEN TJK TKM TUN UKR UZB REG2 ALS ARG BER(USA) CAN HWA MEX REG3 AUS CHN IRN J J(USA) NZL
11 241	REG1 CYP(G) DJI G GIB LBR MLT RUS TUR(USA) REG2 USA REG3 CHN HKG NRU
11 244	REG1 ALG COM CYP(G) DNK G G(USA) GIB KAZ MNG RUS TUR(USA) UZB REG2 B BER(USA) CAN USA REG3 AUS FJI IRN J(USA) NZL PNG
11 247	REG1 ALG CYP(G) EGY G GIB KAZ LBY MLT RUS UZB ZMB REG2 B BER(USA) CAN HWA MEX REG3 AUS CHN CLN FJI GUM HKG J(USA) MLA NZL
11 250	REG1 ALG F G GIB GUI I NIG RUS SEY TUR REG2 CAN REG3 AUS CHN
11 253	REGY ATA(USA) REG1 AZE AZR BHR(USA) BLR ERI ETH F G GRC(USA) I I(USA) KAZ MOZ MRC RUS TJK TKM UKR UZB REG2 ALS B BER(USA) BRB(USA) CG7 HWA MDW PNR PTR TRD(USA) USA REG3 CHN GUM J(USA) MHL(USA)
11 256	REGY ATA(USA) REG1 AZE BHR(USA) BLR ERI ETH G GRC(USA) HOL I I(USA) ISL KAZ MRC RUS TJK TKM UKR UZB REG2 ALS B BRB(USA) CG7 HWA MDW PNR PTR TRD(USA) USA REG3 AUS BRM CHN FJI GUM INS IRN J(USA)
11 259	REGY ATA(USA) REG1 AZR BHR(USA) CYP(G) G ISL MLT MWI UAE UKR REG2 ALS ATG(USA) BAH(USA) BER(USA) BRB(USA) CG7 HWA MDW PNR PTR TCA(USA) TRD(USA) USA REG3 GUM J(USA) SMO
11 262	REGY ATA(ARG) ATA(USA) REG1 CZE D E G GRC(USA) I I(USA) ISL KAZ LTU MDA MRC RUS TUR UKR REG2 ALS ARG BER(USA) CAN CG7 HWA MDW PNR PTR USA REG3 AUS CHN DGA(USA) GUM IND J(USA) MHL(USA)

1	2
11 265	REGY ATA(ARG) ATA(USA) REG1 AZR BEL CZE D EGY GRC(USA) I I(USA) ISL KAZ LTV LVA MDA MNG MRC OMA POR RUS UKR UZB REG2 ALS ARG BER(USA) CAN CG7 HWA MDW PNR PTR USA REG3 CHN GUM IND J(USA) MHL(USA)
11 268	REGY ATA(USA) REG1 ALG ARS BEL COG G ISL KAZ LVA MDG MLT REU RUS SEN SVN UZB REG2 ALS BER(USA) HWA MDW PNR PTR USA REG3 AUS GUM IRN J(USA) MHL(USA)
11 271	REG1 ALG ARS AZE BLR BUL COG F G GEO KAZ MDA MDG MLT MRC REU ROU RUS SEN TJK UKR UZB REG2 B CAN MEX REG3 AUS J(USA)
13 200	REG1 AFS ALG BEL CYP G GMB RUS UAE YEM REG2 ALS GRL HWA USA REG3 AUS J(USA) KRE NPL
13 203	REGY ATA(ARG) REG1 ALG ARS CYP(G) D EGY G GIB KEN NIG ROU RUS SVN TUR TUR(USA) UZB REG2 ALS ARG BES CUW HWA JON MEX SXM USA REG3 AUS HKG IRN J J(USA) PNG
13 206	REGY ATA(ARG) REG1 ALG ARS CYP(G) D E G GIB ISL KEN LBY MLT ROU RUS SOM SUI TUR TUR(USA) UZB REG2 ALS ARG BES CUW GRL HWA JON MEX SXM USA REG3 AUS CLN HKG IRN J MLA NZL SNG*
13 209	REG1 CYP(G) G GIB LIE LSO MLT MNG RUS SDN REG2 BAH REG3 HKG J MLD SMO
13 212	REGY ATA(ARG) REG1 ARS(USA) AZR CAF CME COG CZE D(USA) ERI ETH GRC IRL MDG RUS SEN TUR(USA) REG2 ALS ARG BER(USA) CAN CUB GRL HWA JON PNR PTR USA REG3 AUS BGD CHN GUM J J(USA) MHL(USA) NZL PAK
13 215	REGY ATA(ARG) REG1 ARS(USA) AZR CAF CME COG CZE D(USA) E EGY F G MDG MRC OMA RUS SEN TUR(USA) REG2 ALS ARG BER(USA) CAN CG7 CUB GRL HWA JON MEX PNR PTR USA REG3 AUS BGD CHN GUM IRN J(USA) MHL(USA) NZL PAK
13 218	REG1 CYP(G) DJI G KAZ LBR MLT MWI RUS SMR REG2 ALS CAN HWA MDW MEX URG USA REG3 AUS HKG J MHL(USA)
13 221	REG1 ALG AZE BLR CME COG D DJI(F) GEO GRC(USA) KAZ KGZ LVA MDG MLI REU RUS SEN* TCD TGO TJK TKM TUN UKR UZB REG2 ALS B CAN HWA MDW PNR PTR URG USA REG3 AUS CHN FJI GUM J(USA) KIR MHL(USA) NZL
13 224	REG1 ALG ASC(USA) AZE BLR CME COG CTI D DJI(F) F G GEO HNG JOR KAZ KGZ LVA MDG MLI MNG REU RUS S SEN* SEY(USA) TCD TGO TJK TKM TUN UKR UZB REG2 ALS B CAN CUB HWA MDW PNR PTR USA REG3 AUS CHN FJI GUM IRN J(USA) KIR MHL(USA) NZL PNG

1	2
13 227	REG1 BEL COM GNE IRL KAZ MRC QAT RUS TUR REG2 ALS CAN CUB HWA MDW PNR PTR USA REG3 AUS CBG GUM HKG J(USA) LAO VTN
13 230	REG1 G GRC KAZ LTU MLT RUS SRL UAE YEM ZMB REG2 ALS CAN CG7 HWA MDW PNR PTR USA REG3 GUM J(USA) MHL(USA) PHL TON
13 233	REGY ATA(ARG) REG1 AUT AZR CME COG D D(F) DJI(F) E F ISL KAZ MDG MLI MNG REU RUS SEN* TCD TGO TJK TKM TUN UZB REG2 ALS ARG BER(USA) CAN CG7 HWA MDW MRT PNR PTR USA REG3 CHN GUM J(USA) MHL(USA) NCL OCE
13 236	REGY ATA(ARG) REG1 AUT AZR CME COG CTI D D(F) DJI(F) F G GRC(USA) I(USA) KAZ MDG MLI MRC NIG REU RUS SEN* TCD TGO TJK TKM TUN UZB REG2 ALS ARG BER(USA) CAN CG7 GRL HWA MDW MRT PNR PTR USA REG3 AUS CBG CHN GUM J(USA) LAO MHL(USA) NCL NZL OCE VTN VUT
13 239	REG1 AZR BEN G HOL KAZ KWT LUX NMB ROU RUS REG2 ATG DMA GRD JMC KNA LCA VCT REG3 BRU IRN J NRU
13 242	REG1 ALG ARM AZE BLR CAF CME COG F G G(USA) GEO KAZ MDG POL REU ROU RUS SEN TJK TKM TUN UKR UZB REG2 B BER(USA) HWA JON USA REG3 AUS CHN FJI GUM J(USA) MHL(USA) NZL OCE
13 245	REG1 ALG ARM ASC(USA) AZE BLR CAF CME COG E F G GEO GRC ISR KAZ MDG MNG POL REU RUS SEN TJK TKM TUN UKR UZB REG2 B BER(USA) CAN HWA JON USA REG3 AUS BRM CHN FJI GUM J J(USA) MHL(USA) NZL OCE VTN
13 248	REG1 ALG BLR COD CYP(G) G G(USA) MLT MNE RUS SRB UKR REG2 USA REG3 AUS HKG J SNG TUV
13 251	REGY ATA(ARG) ATA(USA) REG1 AGL ALB AZR BHR(USA) BLR CYP(G) F GRC(USA) I I(USA) MOZ MRC NOR POR RUS STP UKR REG2 ALS ARG CAN CG7 HWA JON MDW MEX PNR PTR USA REG3 AUS CHN GUM IND IRN J(USA) NZL WAK
13 254	REGY ATA(ARG) ATA(USA) REG1 AGL AZR BHR(USA) GRC(USA) HOL I I(USA) MNG MOZ MRC NOR POR RUS STP UZB REG2 ALS ARG BER(USA) CAN CG7 HWA JON MDW MEX PNR PTR USA REG3 AUS BRM CHN GUM IND J(USA) NZL WAK
13 257	REGY ATA(USA) REG1 BEL BHR(USA) CPV G GNB HRV MRC ROU SWZ UZB REG2 CAN CG7 HWA JON MDW PTR USA REG3 AUS GUM INS J(USA) MHL(USA) WAK
15 010	REG1 BEL BEN DJI IRL MLT RUS REG2 BLZ CAN HWA REG3 AUS GUM KRE NPL

1	2
15 013	REGY ATA(ARG) REG1 D(USA) G GRC MLT NIG RUS TUR(USA) UZB REG2 ALS ARG BER(USA) CUB GRL HWA JON PNR USA REG3 GUM J J(USA) MHL(USA)
15 016	REGY ATA(ARG) REG1 ASC(USA) CNR D(USA) E G MRC ROU RUS TUR(USA) UZB REG2 ALS ARG BER(USA) CAN CG7 CUB GRL HWA JON PNR PRU USA REG3 AUS CHN GUM IRN J(USA) MHL(USA) NZL PHL(USA)
15 019	REG1 ARS F LBR MLT ROU RUS UKR REG2 ALS CAN GRL URG USA REG3 AUS J
15 022	REGY ATA(USA) REG1 AGL ALB ARS BHR(USA) BLR GEO ISL KAZ LVA MDA MOZ MRC POR RUS S STP TJK TUR UKR UZB REG2 ALS BRB(USA) CAN HWA MDW PNR PTR TRD(USA) URG USA REG3 AUS CHN DGA(USA) GUM IND IRN J(USA) MAC TLS WAK
15 025	REGY ATA(USA) REG1 AGL ARS AZR BHR(USA) BLR CPV G GEO GNB ISL KAZ LVA MDA MLT MOZ MRC OMA POR RUS STP TJK TUR UKR UZB REG2 ALS ATG(USA) BAH(USA) BER(USA) BRB(USA) CHL HWA MDW MEX PNR PTR TCA(USA) TRD(USA) USA REG3 AUS FJI GUM IND J(USA) MAC NZL TLS WAK
15 028	REGY ATA(USA) REG1 ALG BHR(USA) GRC(USA) ISL MLT RUS TJK REG2 ALS BRB(USA) HWA MDW PNR PTR TRD(USA) USA REG3 AUS GUM J(USA) WAK
15 031	REG1 ALG COM CYP(G) G MLT RUS TJK REG2 ATG CAN DMA GRD JMC KNA LCA VCT REG3 AUS J J(USA)
15 034	REG1 ALG ARS(USA) AZE AZR BLR CME COG D(USA) DJI(F) F G GEO GRC ISR KAZ LTU MDA MDG MLI REU RUS SEN* TCD TJK TKM TUR(USA) UKR UZB REG2 B CAN GRL HWA USA REG3 AUS GUM IRN NZL PHL
15 037	REG1 ALG ARS(USA) AZE AZR BLR CME COG CTI D(USA) G GEO KAZ LTU MDA MDG MLI MNE MRC REU RUS SEN* SRB TCD TJK TKM TUR(USA) UKR UZB REG2 ALS B CAN HWA MEX USA REG3 AUS J(USA)
15 040	REG1 CYP(G) G GUI LIE QAT RUS REG2 USA REG3 AUS J MLD NRU
15 043	REGY ATA(ARG) REG1 CYP(G) DNK ERI ETH G GMB KAZ REG2 ALS ARG CUB REG3 AUS BGD FJI IRN J(USA) PAK
15 046	REGY ATA(ARG) REG1 CYP(G) E ERI ETH G ISL KAZ MLT MNE RUS SRB SUI REG2 ALS ARG CUB USA REG3 AUS BGD FJI J NZL PAK PNG

1	2
15 049	REG1 COD CYP(G) G GIB RUS SMR UAE REG2 USA REG3 AUS HKG J TUV
15 052	REGY ATA(ARG) REG1 BHR(USA) G GRC(USA) I I(USA) MRC NOR RUS REG2 ALS ARG BER(USA) HWA MDW PNR PTR TRD(USA) USA REG3 CHN GUM IND J(USA) MHL(USA) NZL VTN
15 055	REGY ATA(ARG) REG1 AFS ALG ARM BHR(USA) G G(USA) GRC(USA) I I(USA) ISL MRC NOR RUS REG2 ALS ARG BER(USA) HWA MDW PNR PTR TRD(USA) USA REG3 AUS CHN GUM IND J(USA) MHL(USA) NZL VTN
15 058	REG1 ALG ARM BHR(USA) G GRC(USA) I(USA) RUS SWZ REG2 ALS HWA MDW PNR PTR TRD(USA) USA REG3 AUS GUM J(USA) MHL(USA)
15 061	REG1 ALG CNR E F G GRC LSO RUS UZB REG2 ALS BRB(USA) CG7 HWA MDW PNR PTR USA REG3 AUS GUM J(USA) MHL(USA)
15 064	REG1 AZR CME COG DJI(F) F G GRC ISL KAZ KGZ MDG MLI* MTN REU RUS SEN* TCD TGO TJK TKM TUN UZB REG2 ALS ATG(USA) BAH(USA) BER(USA) BRB BRB(USA) CG7 CHL HWA MDW PNR PTR TCA(USA) USA REG3 AUS DGA(USA) GUM J(USA) PNG
15 067	REG1 ALG AZR CME COG CTI DJI(F) F KAZ KGZ MDG MLI* MRC REU RUS SEN TCD TGO TJK TKM TUN UZB REG2 ALS ATG(USA) BAH(USA) BER(USA) BRB BRB(USA) CG7 HWA MDW PNR PTR TCA(USA) USA REG3 AUS CBG GUM J(USA) LAO VTN
15 070	REG1 BEL BHR(USA) GEO RUS SRL TUR REG2 ALS HWA JON MDW PNR PTR USA REG3 AUS GUM J WAK
15 073	REGY ATA(ARG) REG1 BHR(USA) COG D DJI(F) E F GEO GRC(USA) ISL MDG MNG RUS SEN TUN UKR REG2 ALS ARG BER(USA) CAN HWA JON MDW PNR PTR USA REG3 AUS CHN GUM IND J MHL(USA) NCL OCE WAK
15 076	REGY ATA(ARG) REG1 AUT BHR(USA) COG CTI D DJI(F) F G MDG MRC RUS SEN TUN UKR REG2 ALS ARG BER(USA) HWA JON MDW PNR PTR USA REG3 AUS CBG CHN GUM IND IRN J LAO MHL(USA) NCL NZL OCE VTN VUT WAK
15 079	REG1 BDI E G GRC KWT ROU RUS TKM REG2 PTR USA REG3 BRU J TON
15 082	REG1 AZE BHR(USA) BLR CNR E GRC(USA) I I(USA) KAZ KGZ LVA MRC POL ROU RUS TJK TKM UKR REG2 ALS B BER(USA) BRB(USA) HWA MDW MEX PNR PTR USA REG3 AUS FJI GUM J(USA) KIR NZL
15 085	REG1 AZE BHR(USA) BLR CNR DNK E G GRC(USA) HOL I I(USA) KAZ KGZ LVA MNG MRC NIG POL RUS TJK TKM UKR REG2 ALS B BER(USA) BRB(USA) HWA MDW MEX PNR PTR TRD(USA) USA REG3 AUS CHN FJI GUM J(USA) KIR MHL(USA) NZL PNG

1	2
15 088	REG1 BEL BHR(USA) BLR E RUS UAE REG2 ALS ATG(USA) BAH(USA) BER(USA) BRB(USA) HWA MDW PNR PTR TCA(USA) USA REG3 AUS GUM HKG J(USA)
15 091	REG1 E G HRV MLT RUS ZMB REG2 B MEX USA REG3 AUS HKG IRN J J(USA)
15 094	REGY ATA(ARG) REG1 E HOL MLT MNG MWI RUS TUR REG2 ALS ARG BER(USA) BES CUW GTM HWA SXM USA REG3 AUS CHN GUM J
15 097	REG1 CYP IRL RUS SDN TUR REG2 ALS ARG BAH BER(USA) REG3 INS J SMO
17 970	REG1 AFS ALG CYP DJI G KWT MCO RUS REG2 ATG DMA GRD JMC KNA LCA VCT REG3 BRU PHL SMO
17 973	REGY ATA(ARG) REG1 AGL ALG ARM ARS(USA) AZE AZR BLR CYP(G) D F G I KAZ LTU LVA MDA MNG MOZ NIG POR ROU RUS STP SVN TJK TKM UKR UZB REG2 ALS ARG BER(USA) GRL HWA JON USA REG3 AUS GUM IND IRN J(USA) MAC MHL(USA) TLS
17 976	REG1 CPV D G G(USA) I MNE MRC ROU RUS SRB SWZ TUR(USA) UAE UZB REG2 CAN GRL URG USA REG3 AUS J(USA) MLD
17 979	REG1 BHR(USA) CYP(G) E G GIB GRC(USA) I I(USA) LSO MRC RUS UZB REG2 ALS B BER(USA) CG7 HWA MDW PNR PTR TRD(USA) USA REG3 AUS BGD GUM HKG J(USA) NZL PAK
17 982	REG1 ARS AZR BHR(USA) CYP(G) EGY G GIB GRC(USA) I I(USA) ISL JOR KEN MLT MRC OMA RUS S UKR REG2 ALS B BER(USA) CAN CG7 HWA MDW PNR PTR TRD(USA) USA REG3 AUS BGD GUM HKG IRN J(USA) MHL(USA) NZL PAK PNG
17 985	REG1 BEN BHR(USA) D G ISL LBY MNG SOM UKR REG2 ALS BER(USA) CG7 HWA MDW PNR PTR TRD(USA) USA REG3 AUS CLN GUM J(USA) MLA SNG
17 988	REG1 CYP(G) G GIB LIE MLT NIG RUS TUN REG2 BAH REG3 AUS HKG IND J
17 991	REGY ATA(ARG) REG1 AFS CME COG D D(F) DJI(F) F GAB GRC HOL ISL MDG MLI* MTN* REU RUS SEN TCD TGO TUN REG2 ALS ARG BER(USA) GRL HWA JON MRT USA REG3 AUS CHN FJI GUM J NCL NZL OCE
17 994	REGY ATA(ARG) REG1 ALG AUT CME COG CTI D D(F) DJI(F) F ISR MDG MLI MNG MRC REU RUS SEN* TCD TGO TKM TUN UKR REG2 ALS ARG CAN GRL HWA JON MRT USA REG3 AUS CBG CHN FJI GUM IRN J LAO NCL NZL OCE VTN VUT
17 997	REG1 ALG CYP(G) G GIB LUX MLT MWI RUS TKM UKR REG3 HKG J TON



1	2
18 000	REGY ATA(ARG) REG1 ALG BLR G GEO GRC KAZ LVA POL RUS TJK TUR UKR UZB ZMB REG2 ARG CAN MEX USA REG3 AUS BGD J J(USA) NZL PAK
18 003	REGY ATA(ARG) REG1 ALG BLR COM CYP(G) G GEO KAZ LVA MLT MNG POL RUS TJK TUR UAE UKR UZB REG2 ALS ARG MEX USA REG3 AUS J(USA) NZL PNG
18 006	REG1 BEL G HOL LBR MLT RUS SMR REG2 BLZ REG3 AUS IRN J(USA)
18 009	REGY ATA(USA) REG1 BHR(USA) CME COG CYP(G) D DJI(F) E F G GRC(USA) I I(USA) ISL MDG MLI MLT MRC REU ROU RUS SEN* TCD TGO TUN REG2 ALS ATG(USA) BAH(USA) BER(USA) BRB BRB(USA) CAN CG7 HWA MDW PNR PTR TCA(USA) USA REG3 AUS CHN FJI GUM J MHL(USA) NZL
18 012	REGY ATA(USA) REG1 BHR(USA) CME COG CTI D DJI(F) E F G GRC(USA) I I(USA) MDG MLI* MRC MTN REU ROU RUS SEN* TCD TGO TUN REG2 ALS BER(USA) BRB(USA) CAN CG7 CHL HWA MDW PNR PTR USA REG3 CHN FJI GUM J(USA) MHL(USA) NZL
18 015	REGY ATA(USA) REG1 ALG BHR(USA) CNR E F G GRC(USA) I(USA) MNG MRC RUS UKR REG2 ALS BRB(USA) CAN CG7 GRL HWA MDW PNR PTR USA REG3 AUS CHN GUM HKG J(USA)
18 018	REG1 ASC(USA) E G G(USA) HRV RUS SRL UKR REG2 CAN REG3 AUS HKG IRN J(USA)
18 021	REG1 AZE BEL BLR E G GEO GHA GRC KAZ KGZ LVA OMA RUS TJK TKM UKR REG2 B BER(USA) USA REG3 GUM J TUV
18 024	REG1 AZE BLR E G GEO KAZ KGZ LVA MNG MOZ POR RUS S SUI TJK TKM TUR UKR REG2 B BER(USA) CAN GRL USA REG3 AUS FJI INS J(USA)
18 027	REG1 BEL G GMB NMB QAT RUS SSD TUR REG2 CAN USA REG3 AUS KRE NPL NRU

## NOTES ON THE CONCLUDED OPERATIONAL AGREEMENTS

1 The Administrations of Canada and the United States of America informed the Radiocommunication Bureau that they had concluded an operational agreement. The agreement constitutes a sharing arrangement between the two countries for use of all shared allotments appearing in the present version of Part III of this Appendix.

2 The Administrations of Mali, Mauritania and Senegal concluded an operational agreement whose terms of reference are given as follows:

2.1 the use of the following allotments by Mali is subject to coordination with the administrations of Mauritania and Senegal: 3 044, 3 047, 3 143, 3 149, 3 152, 3 900, 4 745, 5 702, 6 712, 6 742, 15 064, 15 067, 17 991 and 18 012 kHz;

2.2 the use of the following allotments by Mauritania is subject to coordination with the administrations of Mali and Senegal: 3 038, 5 708, 5 711, 6 715 and 17 991 kHz;

2.3 the use of the following allotments by Senegal is subject to coordination with the administrations of Mali and Mauritania: 3 044, 3 047, 3 050, 3 053, 3 056, 3 059, 3 140, 3 149, 3 903, 4 736, 4 739, 4 742, 5 702, 5 717, 5 723, 5 726, 6 712, 6 715, 6 745, 6 751, 8 983, 8 998, 9 001, 13 221, 13 224, 13 233, 13 236, 15 034, 15 037, 15 064, 17 994, 18 009 and 18 012 kHz.

3 The Administrations of Brunei Darussalam, Malaysia and Singapore concluded an operational agreement whose terms of reference are given as follows:

3.1 the use of the following allotments by Singapore is subject to coordination with the Administration of Malaysia: 3 074, 3 095, 3 101, 3 116, 4 718, 6 685, 6 694, 6 700, 6 730, 6 760, 8 968, 11 199 and 13 206 kHz;

3.2 the use of the following allotments by Malaysia is subject to coordination with the administration of Singapore: 3 080, 4 739, 6 724 and 9 019 kHz.

### PART IV – Criteria for compatibility assessment

26/6 For assessment of the possibilities of sharing between the allotments contained in Part III of this Appendix, and any new assignment which is not covered by an appropriate allotment, the following criteria shall be used:

26/6.1 A new station, not covered by an allotment, which uses the standardized transmission characteristics (J3E, 36 dBW (PX)) shall be considered compatible with the Plan, if it fulfils the criterion of being separated from any point of any allotment area, indicated in the Plan on the given channel, by the repetition half distance, determined for the given conditions of operation (frequency band used, geographical position of the station, direction of propagation), which are given below:

Frequency band (kHz)	Repetition half-distance (km)			
	Northern hemisphere		Southern hemisphere	
	North-South	East-West	North-South	East-West
3 025- 3 155	550	600	550	600
3 900- 3 950	650	650	650	650
4 700- 4 750	725	775	725	775
5 680- 5 730	1 175	1 325	1 150	1 300
6 685- 6 765	1 350	1 600	1 225	1 425
8 965- 9 040	2 525	3 525	2 225	3 075
11 175-11 275	3 375	5 575	2 675	3 925
13 200-13 260	4 550	6 650	3 475	5 625
15 010-15 100	5 050	7 450	4 800	7 100
17 970-18 030	5 750	8 250	5 675	7 475

26/6.2 The relevant value of the repetition half distance for paths which are situated partly in the northern hemisphere and partly in the southern hemisphere shall be corrected using the linear interpolation procedure. This procedure shall be used to calculate the correction due to the azimuth of the propagation path with respect to true North.

26/6.3 The relevant value of the repetition half distance, obtained in accordance with No. 26/6.2, shall be corrected, where necessary, to take into account the difference in the radiated power of the assignment with respect to the reference radiated power (30 dBW, mean radiated power) on the basis that a variation of 1 dB in the radiated power corresponds to a variation of 4% in the repetition distance.

**PART V – Procedure for modification and maintenance of Part III**

26/7 Part III will be updated by the Bureau in accordance with the following procedure:

26/7.1 a) when a country which has no allotment in Part III requests an allotment, the Bureau shall select an appropriate allotment on a priority basis and shall enter it in Part III;

26/7.2 b) when a request is submitted for an additional allotment, the Bureau shall apply the criteria of Part IV, and, where appropriate, enter the corresponding allotment in Part III;

26/7.3 c) when an administration informs the Bureau that it renounces the use of an allotment, the Bureau shall cancel the allotment concerned from Part III.

26/8 The Bureau shall maintain an up-to-date master copy of Part III, and shall periodically, but no less frequently than once a year, prepare recapitulative documents listing all amendments made to Part III.

26/9 The Secretary-General shall publish an up-to-date version of Part III in an appropriate form at least once every four years.

## APPENDIX 27 (REV.WRC-19)\*

**Frequency allotment Plan for the aeronautical mobile (R)  
service and related information**

(See Article 43)

## TABLE OF CONTENTS

**PART I – General provisions**

	<i>Page</i>
Section I	Definitions ..... 3
Section II	Technical and operational principles used for the establishment of the Plan of allotment of frequencies in the aeronautical mobile (R) service
A – Channel characteristics and utilization.....	4
B – Interference range contours .....	7
Major world air route area maps (MWARAs) (Maps 1a, 1b, 4 and 6)	Pocket
Regional and domestic air route area maps (RDARAs) (Maps 2a, 2b, 5 and 7)	
VOLMET allotment and reception area maps (Maps 3a, 3b, 8 and 9)	
Transparencies used with above Maps	
C – Classes of emission and power .....	21
D – Limits to the power levels of unwanted emissions.....	23
E – Other technical provisions .....	24

\* *Note by the Secretariat:* This edition of Appendix 27 incorporates editorial amendments to the Appendix 27 Aer2 as adopted by the WARC-Aer2.

The references in Appendix 27 now conform to the new numbering scheme of the Radio Regulations. In addition, the text of Appendix 27 contains updated definitions of the relevant aeronautical areas conforming with the new geographical situation reflecting the political changes since 1979. It also contains updated references to the classes of emissions in accordance with Article 2. (WRC-03)

**PART II – Plan for the allotment of frequencies for the aeronautical mobile (R) service  
in the exclusive bands between 2 850 and 22 000 kHz**

*Page*

Section I	Description of the boundaries of the areas and sub-areas	
Article 1	Description of the boundaries of the major world air route areas (MWARAs).....	25
Article 2	Description of the boundaries of the regional and domestic air route areas (RDARAs) .....	27
Article 3	Description of the boundaries of the VOLMET allotment areas and VOLMET reception areas.....	42
Article 4	World-wide allotment areas .....	44
Section II	Allotment of frequencies in the aeronautical mobile (R) service	
Article 1	Frequency allotment Plan by areas.....	45
Article 2	Frequency allotment Plan (in numerical order of frequencies)	54
Article 3	Frequencies for common use.....	75

## PART I – General provisions

### Section I – Definitions

**27/1**        1        *Frequency allotment Plan*: A Plan which shows the frequencies to be used in particular areas without specifying the stations to which the frequencies are to be assigned.

**27/2**        2        The terms to express the different methods of frequency distribution as used in this Appendix have the following meanings:

Frequency distribution to	French	English	Spanish	Arabic	Chinese	Russian
Services	Attribution (attribuer)	Allocation (to allocate)	Atribución (atribuir)	توزيع (يوزع)	划分 (划分)	<i>Распределение</i> (распределить)
Areas or countries	Allotissement (allotir)	Allotment (to allot)	Adjudicación (adjudicar)	تعيين (يعين)	分配 (分配)	<i>Выделение</i> (выделить)
Stations	Assignment (assigner)	Assignment (to assign)	Asignación (asignar)	تخصيص (يخصص)	指配 (指配)	<i>Присвоение</i> (присвоить)

**27/3**        3        *A major world air route* is a long-distance route, made up of one or more segments, essentially international in character, extending through more than one country and requiring long-distance communication facilities.

**27/4**        4        *A major world air route area (MWARA)* is an area embracing a certain number of major world air routes, which generally follow the same traffic pattern and are so related geographically that the same frequency families may logically be applied.

**27/5**        5        *Regional and Domestic Air Route* are all those using the Aeronautical Mobile (R) Service not covered by the definition of a Major World Air Route in No. 27/3.

**27/6**        6        *Regional and Domestic Air Route Area (RDARA)* is an area embracing a certain number of the air routes defined in No. 27/5.

**27/7**        7        *A VOLMET Allotment Area* is an area encompassing all points where an HF broadcast facility might be required to operate on a family of frequencies common to the area.

**27/8**        8        *A VOLMET Reception Area* is an area within which aircraft should be able to receive broadcasts from one or more stations in the associated VOLMET Allotment Area.

**27/9**      9      *A World-Wide Allotment Area* is one in which frequencies are allotted to provide long-distance communication between an aeronautical station within that allotment area and aircraft operating anywhere in the world<sup>1</sup>.

**27/10**      10      *Family of Frequencies in the Aeronautical Mobile (R) Service* contains two or more frequencies selected from different aeronautical mobile (R) bands and is intended to permit communication at any time within the authorized area of use (see Nos. **27/213** to **27/231**) between aircraft stations and appropriate aeronautical stations.

**Section II – Technical and operational principles used  
for the establishment of the Plan of allotment of frequencies  
in the aeronautical mobile (R) service**

**A – Channel characteristics and utilization**

**1      Frequency separation**

**27/11**      1.1      The frequency separation between carrier (reference) frequencies shall be 3 kHz. This is adequate to permit communications using the classes of emission referred to in Nos. **27/56** to **27/59** in the frequency bands between 2 850 kHz and 22 000 kHz allocated exclusively to the aeronautical mobile (R) service. The carrier (reference) frequency of the channels in the Plan shall be an integral multiple of 1 kHz.

**27/12**      1.2      For radiotelephone emissions the audio frequencies will be limited to between 300 Hz and 2 700 Hz and the occupied bandwidth of other authorized emissions will not exceed the upper limit of J3E emissions. In specifying these limits, however, no restriction in their extension is implied in so far as emissions other than J3E are concerned, provided that the limits of unwanted emissions are met (see Nos. **27/73** and **27/74**).

**27/13**      NOTE – For aircraft and aeronautical station transmitter types first installed before 1 February 1983, the audio frequencies will be limited to 3 000 Hz.

**27/14**      1.3      On account of the possibility of interference, a given channel should not be used in the same allotment area for radiotelephony and data transmissions.

**27/15**      1.4      The use of channels derived from the frequencies indicated in No. **27/18** for the various classes of emissions other than J3E and H2B will be subject to special arrangements by the administrations concerned and affected in order to avoid harmful interference which may result from the simultaneous use of the same channel for several classes of emission.

---

<sup>1</sup> **27/9.1**      The type of communication referred to in **27/9** may be regulated by administrations.

27/16 1.5 To preclude the possibility of interference, adjacent channels in the list of frequencies in No. 27/18 have not as a rule been allotted to the same MWARA, RDARA or VOLMET areas. However, to satisfy particular needs, the administrations concerned may conclude special arrangements for the assignment of adjacent channels derived from the frequencies in the Table.

27/17 1.6 The arrangements contemplated in Nos. 27/15 and 27/16 should be made under the Articles of the Constitution and Convention of the International Telecommunication Union and the Radio Regulations entitled "Special agreements"\* (WRC-03)

## 2 Frequencies allotted

27/18 The list of carrier (reference) frequencies allotted in the bands allocated exclusively to the aeronautical mobile (R) service, on the basis of the frequency separation provided for under No. 27/11, will be found in the following Table<sup>2</sup>.

---

\* *Note by the Secretariat:* The relevant Article in the Radio Regulations is now Article 6 entitled "Special Agreements".

<sup>2</sup> 27/18.1 To calculate the assigned frequency from a carrier (reference) frequency given in the table, reference should be made to Nos. 27/75, 27/77 and 27/78.



AP27-6

2 850-3 025 kHz		
2 851	2 938	57 chan- nels
2 854	2 941	
2 857	2 944	
2 860	2 947	
2 863	2 950	
2 866	2 953	
2 869	2 956	
2 872	2 959	
2 875	2 962	
2 878	2 965	
2 881	2 968	
2 884	2 971	
2 887	2 974	
2 890	2 977	
2 893	2 980	
2 896	2 983	
2 899	2 986	
2 902	2 989	
2 905	2 992	
2 908	2 995	
2 911	2 998	
2 914	3 001	
2 917	3 004	
2 920	3 007	
2 923	3 010	
2 926	3 013	
2 929	3 016	
2 932	3 019	
2 935		
	(R) and (OR)	
	3 023	
3 400-3 500 kHz		
3 401	3 452	33 chan- nels
3 404	3 455	
3 407	3 458	
3 410	3 461	
3 413	3 464	
3 416	3 467	
3 419	3 470	
3 422	3 473	
3 425	3 476	
3 428	3 479	
3 431	3 482	
3 434	3 485	
3 437	3 488	
3 440	3 491	
3 443	3 494	
3 446	3 497	
3 449		
	(R) and (OR)	
	5 680	

4 650-4 700 kHz		
4 651	4 675	16 chan- nels
4 654	4 678	
4 657	4 681	
4 660	4 684	
4 663	4 687	
4 666	4 690	
4 669	4 693	
4 672	4 696	
5 450-5 480 kHz		
Region 2		
5 451	5 466	9 chan- nels
5 454	5 469	
5 457	5 472	
5 460	5 475	
5 463		
5 480-5 680 kHz		
5 481	5 580	66 chan- nels
5 484	5 583	
5 487	5 586	
5 490	5 589	
5 493	5 592	
5 496	5 595	
5 499	5 598	
5 502	5 601	
5 505	5 604	
5 508	5 607	
5 511	5 610	
5 514	5 613	
5 517	5 616	
5 520	5 619	
5 523	5 622	
5 526	5 625	
5 529	5 628	
5 532	5 631	
5 535	5 634	
5 538	5 637	
5 541	5 640	
5 544	5 643	
5 547	5 646	
5 550	5 649	
5 553	5 652	
5 556	5 655	
5 559	5 658	
5 562	5 661	
5 565	5 664	
5 568	5 667	
5 571	5 670	
5 574	5 673	
5 577	5 676	
	(R) and (OR)	
	5 680	

6 525-6 685 kHz		
6 526	6 607	53 chan- nels
6 529	6 610	
6 532	6 613	
6 535	6 616	
6 538	6 619	
6 541	6 622	
6 544	6 625	
6 547	6 628	
6 550	6 631	
6 553	6 634	
6 556	6 637	
6 559	6 640	
6 562	6 643	
6 565	6 646	
6 568	6 649	
6 571	6 652	
6 574	6 655	
6 577	6 658	
6 580	6 661	
6 583	6 664	
6 586	6 667	
6 589	6 670	
6 592	6 673	
6 595	6 676	
6 598	6 679	
6 601	6 682	
6 604		
8 815 -8 965 kHz		
8 816	8 891	49 chan- nels
8 819	8 894	
8 822	8 897	
8 825	8 900	
8 828	8 903	
8 831	8 906	
8 834	8 909	
8 837	8 912	
8 840	8 915	
8 843	8 918	
8 846	8 921	
8 849	8 924	
8 852	8 927	
8 855	8 930	
8 858	8 933	
8 861	8 936	
8 864	8 939	
8 867	8 942	
8 870	8 945	
8 873	8 948	
8 876	8 951	
8 879	8 954	
8 882	8 957	
8 885	8 960	
8 888		
	(R) and (OR)	

10 005-10 100 kHz		
10 006	10 054	31 chan- nels
10 009	10 057	
10 012	10 060	
10 015	10 063	
10 018	10 066	
10 021	10 069	
10 024	10 072	
10 027	10 075	
10 030	10 078	
10 033	10 081	
10 036	10 084	
10 039	10 087	
10 042	10 090	
10 045	10 093	
10 048	10 096	
10 051		
11 275-11 400 kHz		
11 276	11 339	41 chan- nels
11 279	11 342	
11 282	11 345	
11 285	11 348	
11 288	11 351	
11 291	11 354	
11 294	11 357	
11 297	11 360	
11 300	11 363	
11 303	11 366	
11 306	11 369	
11 309	11 372	
11 312	11 375	
11 315	11 378	
11 318	11 381	
11 321	11 384	
11 324	11 387	
11 327	11 390	
11 330	11 393	
11 333	11 396	
11 336		

13 260-13 360 kHz		
13 261	13 312	33 chan- nels
13 264	13 315	
13 267	13 318	
13 270	13 321	
13 273	13 324	
13 276	13 327	
13 279	13 330	
13 282	13 333	
13 285	13 336	
13 288	13 339	
13 291	13 342	
13 294	13 345	
13 297	13 348	
13 300	13 351	
13 303	13 354	
13 306	13 357	
13 309		
17 900-17 970 kHz		
17 901	17 937	23 chan- nels
17 904	17 940	
17 907	17 943	
17 910	17 946	
17 913	17 949	
17 916	17 952	
17 919	17 955	
17 922	17 958	
17 925	17 961	
17 928	17 964	
17 931	17 967	
17 934		
21 924-22 000 kHz		
21 925	21 964	25 chan- nels
21 928	21 967	
21 931	21 970	
21 934	21 973	
21 937	21 976	
21 940	21 979	
21 943	21 982	
21 946	21 985	
21 949	21 988	
21 952	21 991	
21 955	21 994	
21 958	21 997	
21 961		

27/19 3 The International Civil Aviation Organization (ICAO) coordinates radiocommunications of the aeronautical mobile (R) service with international aeronautical operations and this Organization should be consulted in all appropriate cases in the operational use of the frequencies in the Plan.

### 3 Adaptation of allotment procedure

27/20 It is recognized that not all the sharing possibilities have been exhausted in the allotment Plan contained in this Appendix. Therefore, in order to satisfy particular operational requirements which are not otherwise met by this allotment Plan, Administrations may assign frequencies from the aeronautical mobile (R) bands in areas other than those to which they are allotted in this Plan. However, the use of the frequencies so assigned must not reduce the protection to the same frequencies in the areas where they are allotted by the Plan below that determined by the application of the procedure defined in Part I, Section II B of this Appendix.

27/21 5 When necessary to satisfy the needs of international air operations Administrations may adapt the allotment procedure for the assignment of aeronautical mobile (R) frequencies, which assignments shall then be the subject of prior agreement between Administrations affected.

27/22 6 The coordination described in No. 27/19 shall be effected where appropriate and desirable for the efficient utilization of the frequencies in question, and especially when the procedures of No. 27/21 are unsatisfactory.

## B – Interference range contours

### 27/23 1 General provisions

#### 27/24 1.1 Service range

Due to factors such as the power of the transmitter, propagation loss, noise level, etc., there is a limit to the distance at which reliable communications can be effected between an aeronautical station and an aircraft station. This limiting distance, based on the weakest path, is the service range. The boundary of the air route area is often assumed to be the limiting distance.

#### 27/25 1.2 Interference range

This is the minimum distance from the limit of the service range of a wanted station to a potentially interfering station needed to produce a protection ratio of 15 dB. This protection ratio is between the wanted signal at an aircraft station at the limit of the service range and the signal from a potentially interfering aeronautical station operating on the same frequency. The interference range has been calculated for different frequencies indicated on the data Tables contained in Nos. 27/46 to 27/55 for day and night conditions, for median latitudes, for conditions of median sunspot activity and for a mean effective radiated power of 1 kW at the aeronautical station.

27/26 1.3 Repetition distance

This is the distance at which a frequency may be successfully shared and is equal to the sum of the service range and the interference range.

27/27 1.4 Figure 1 illustrates the use of the concept of interference range in frequency planning through the determination of repetition distance.

FIGURE 1  
Service range, interference range, repetition distance

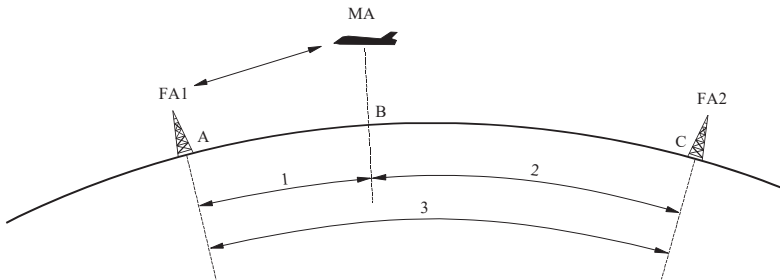

- FA1 : aeronautical station in communication with aircraft station MA
- FA2 : aeronautical station in communication with aircraft stations other than MA
- MA : aircraft station in communication with aeronautical station FA1
- 1 : service range AB
- 2 : interference range CB
- 3 : repetition distance AC

AP27-01

27/28 1.5 The transparencies associated with this Appendix show, for the frequencies stated, the interference range defined in No. 27/25 between an interfering aeronautical station and an aircraft station operating at the limit of its service range. Because of the variability of propagation conditions not only from hour to hour within the daytime and night time periods but also from day to day, with season, with solar activity level and geographic location, the 15 dB protection ratio may be expected to have marked variations and accordingly a greater protection may be available much of the time, especially when the aircraft is not operating at the limit of its service range.

27/29 (SUP - WRC-03)

27/30 1.7 Two types of transparencies are provided for use respectively with the Mercator projection world maps and the Lambert azimuthal equal area of projection maps for the polar areas. The Mercator projection transparencies encompass the area between latitude 60° North and 60° South. The transparencies associated with the Polar area projections encompass the areas north of latitude 30° North and south of latitude 30° South. The Mercator projection overlaps the Polar projection maps between latitudes 30° and 60° North and 30° and 60° South. This overlap is intended to provide continuity between transparencies, of the two projections.

## 2 Type of maps used

27/31 The transparencies mentioned in Nos. 27/28 and 27/30, can be used only on a world or polar map of the projection and scales given on each transparency and will not be suitable for use on any other projection or scale. The world and polar maps associated with this Appendix, depicting MWARA, RDARA and VOLMET areas, are to the correct scale so that the transparencies carrying the interference range contours can be directly used on these maps. The auroral zones are marked on the polar maps.

## 3 Change of scale of projection

27/32 3.1 Should any other scale or projection be desired, then new interference range contours can be drawn to fit the new scales or projections by using the coordinates given in the Tables shown below.

27/33 3.2 When new transparencies are constructed, the intersection of the vertical line of symmetry, i.e., the meridian of longitude and the horizontal line of latitude should be at 00° latitude for the 00° contour, 20° N for the 20° contour, 40° N for 40° contour, etc.

27/34 3.3 The coordinates shown in the Tables under Nos. 27/46 to 27/55 are given with reference to the 180° meridian taken as the axis of symmetry for the construction of the contours.

## 4 Sharing conditions between areas

### 4.1 Frequency bands between 3 and 11.3 MHz

27/35 4.1.1 The transparencies are constructed on the basis of the following sharing conditions:

Areas	Bands between (MHz)	Sharing conditions
MWARA or VOLMET area to MWARA or VOLMET area	3 and 6.6 9 and 11.3	Night propagation Day propagation NOTE – 6.6 MHz and 5.6 MHz sharing conditions are considered to be the same.
MWARA or VOLMET area to RDARA	3 and 5.6 6.6 and 11.3	Night propagation Day propagation
RDARA to RDARA	3 and 4.7 5.6 and 11.3	Night propagation Day propagation

27/36 4.1.2 The additional “Day” contours included for 3 MHz, 3.5 MHz and 4.7 MHz are for determining daylight sharing possibilities.

## **4.2 Frequency bands between 13 and 22 MHz**

**27/37** 4.2.1 The revised frequency allotment Plan for the 13 MHz, 18 MHz and 22 MHz bands is based on daytime protection only. This results in the following sharing possibilities:

**27/38** 4.2.2 for the 13 MHz band, the repetition factor is at least 3 whilst for the 18 and 22 MHz bands it is 4. It is to be noted that the longitudinal separation might be decreased to allow for a repetition of 4 (at 13 MHz) and 6 (at 18 and 22 MHz), taking into account operational and local circumstances;

**27/39** 4.2.3 the sharing takes into account the likely locations of the aeronautical stations rather than the area boundaries.

## **5 Method of use of the transparencies for the bands 3 to 11.3 MHz**

**27/40** 5.1 Take the appropriate MWARA, RDARA or VOLMET area map associated with this Appendix and select the transparency for the frequency order and sharing conditions under consideration.

**27/41** 5.2 The equal area projections (Lambert) are applicable in the polar areas north of 60° N and south of 60° S; and the Mercator projections are applicable between 60° N and 60° S.

**27/42** 5.3 Place the centre of the transparency (i.e. the intersection of the axis of symmetry and the latitude line) over the boundary of the area (use the reception area boundary in the case of VOLMET) at the point on the boundary nearest to the potentially interfering transmitter or at the location of the interfering transmitter. Note the latitude of the selected point and use the interference range contour corresponding to this latitude.

**27/43** 5.4 A transmitter located at any point outside the contour will result, as defined in No. **27/25**, in a protection ratio of better than 15 dB.

**27/44** 5.5 A transmitter located at any point inside the contour will result in a protection ratio of less than 15 dB. However, if the transmitter is located inside the contour but the propagation path traverses an auroral zone, it is assumed that the signal attenuation within this zone will result in a protection ratio of better than 15 dB.

**27/45** 5.6 For the Northern Hemisphere the Mercator projection transparencies should be used in their natural position as published, but for the Southern Hemisphere the transparencies should be inverted. This point should be carefully observed when following the boundaries of areas which involve the transition of the equator.

## 6 Data for tracing interference contours

27/46 3.0 and 3.5 MHz day

### Data for plotting 700 km interference contours

Latitude	00°		10°		20°		30°		40°	
	Long.	Lat.	Long.	Lat.	Long.	Lat.	Long.	Lat.	Long.	Lat.
Coordinates for plotting contours	180.0	6.3	180.0	16.3	180.0	26.3	180.0	36.3	180.0	46.3
	178.9	6.2	178.9	16.2	178.8	26.2	178.6	36.2	178.4	46.2
	177.8	5.9	177.8	15.9	177.6	25.9	177.3	35.9	176.9	45.9
	176.8	5.5	176.7	15.4	176.5	25.4	176.1	35.4	175.5	45.4
	175.9	4.8	175.8	14.8	175.5	24.8	175.1	34.7	174.3	44.7
	175.2	4.0	175.0	14.0	174.7	24.0	174.2	33.9	173.3	43.9
	174.5	3.1	174.4	13.1	174.1	23.0	173.5	33.0	172.5	42.9
	174.1	2.2	173.9	12.1	173.6	22.0	173.0	32.0	172.0	41.9
	173.8	1.1	173.7	11.0	173.4	21.0	172.8	30.9	171.8	40.8
	173.7	0.0	173.6	9.9	173.3	19.9	172.7	29.8	171.8	39.7
	173.8	-1.1	173.7	8.8	173.4	18.8	172.9	28.7	172.0	38.6
	174.1	-2.2	174.0	7.8	173.8	17.7	173.3	27.7	172.5	37.6
	174.5	-3.1	174.5	6.8	174.3	16.8	173.9	26.7	173.2	36.6
	175.2	-4.0	175.2	5.9	175.0	15.9	174.6	25.8	174.1	35.8
	175.9	-4.8	175.9	5.2	175.8	25.1	175.5	25.1	175.1	35.1
	176.8	-5.5	176.8	4.5	176.8	14.5	176.5	24.5	176.2	34.5
	177.8	-5.9	177.8	4.1	177.8	14.1	177.6	24.1	177.4	34.0
	178.9	-6.2	178.9	3.8	178.9	13.8	178.8	23.8	178.7	33.8
	180.0	-6.3	180.0	3.7	180.0	13.7	180.0	23.7	180.0	33.7

Latitude	50°		60°		70°		80°		90°	
	Long.	Lat.	Long.	Lat.	Long.	Lat.	Long.	Lat.	Long.	Lat.
Coordinates for plotting contours	180.0	56.3	180.0	66.3	180.0	76.3	180.0	86.3	All longitudes	83.7
	178.0	56.2	177.3	66.2	175.4	76.2	163.9	86.1		83.7
	176.2	55.9	174.7	65.8	171.2	75.8	152.2	85.4		83.7
	174.5	55.3	172.5	65.3	167.7	75.1	145.2	84.5		83.7
	173.0	54.6	170.6	64.5	164.9	74.3	141.9	83.4		83.7
	171.8	53.8	169.1	63.6	162.9	73.4	140.8	82.4		83.7
	171.0	52.8	168.1	62.7	161.8	72.3	141.3	81.3		83.7
	170.4	51.8	167.5	61.6	161.3	71.2	142.8	80.2		83.7
	170.2	50.7	167.3	60.5	161.5	70.1	144.9	79.2		83.7
	170.3	49.6	167.5	59.4	162.1	69.1	147.6	78.2		83.7
	170.6	48.5	168.1	58.3	163.2	68.0	150.5	77.3		83.7
	171.2	47.5	169.0	57.4	164.6	67.1	153.8	76.5		83.7
	172.1	46.6	170.1	56.4	166.4	66.2	157.3	75.8		83.7
	173.1	45.7	171.4	55.6	168.3	65.5	160.8	75.2		83.7
	174.3	45.0	172.9	55.0	170.4	64.9	164.6	74.6		83.7
	175.6	44.5	174.6	54.4	172.7	64.4	168.4	74.2		83.7
	177.0	44.0	176.3	54.0	175.1	64.0	172.2	73.9		83.7
	178.5	43.8	178.2	53.8	177.5	63.8	176.1	73.8		83.7
	180.0	43.7	180.0	53.7	180.0	63.7	180.0	73.7		83.7

Data for plotting 3 500 km interference contours

Latitude	00°		10°		20°		30°		40°	
	Long.	Lat.	Long.	Lat.	Long.	Lat.	Long.	Lat.	Long.	Lat.
Coordinates for plotting contours	180.0	31.5	180.0	41.5	180.0	51.5	180.0	61.5	180.0	71.5
	173.9	31.0	173.1	40.9	171.7	50.8	169.3	60.7	164.3	70.4
	168.2	29.4	166.7	39.2	164.2	48.9	160.1	58.4	152.1	67.5
	163.0	26.9	161.1	36.4	158.0	45.8	153.0	54.9	144.2	63.5
	158.5	23.6	156.4	32.8	153.2	41.9	148.0	50.6	139.7	58.7
	154.9	19.6	152.9	28.6	149.8	37.4	144.9	45.8	137.5	53.6
	152.0	15.1	150.3	23.9	147.6	32.5	143.3	40.7	137.0	48.4
	150.1	10.3	148.7	18.9	146.4	27.4	142.9	35.5	137.6	43.2
	148.9	5.2	148.0	13.7	146.3	22.1	143.4	30.3	139.1	38.1
	148.5	0.0	148.1	8.5	146.9	17.0	144.7	25.2	141.3	33.2
	148.9	-5.2	149.0	3.4	148.3	11.9	146.7	20.9	144.1	28.6
	150.1	-10.3	150.6	-1.6	150.3	7.1	149.3	15.8	147.4	24.3
	152.0	-15.1	152.9	-6.3	153.1	2.6	152.5	11.5	151.1	20.4
	154.9	-19.6	156.0	-10.5	156.4	-1.4	156.2	7.8	155.3	16.9
	158.5	-23.6	159.7	-14.2	160.3	-4.8	160.3	4.6	159.8	14.0
	163.0	-26.9	164.1	-17.3	164.7	-7.7	164.8	2.0	164.5	11.6
	168.2	-29.4	169.1	-19.6	169.6	-9.8	169.7	0.1	169.5	9.9
	173.9	-31.0	174.4	-21.0	174.7	-11.1	174.8	-1.1	174.7	8.9
	180.0	-31.5	180.0	-21.5	180.0	-11.5	180.0	-1.5	180.0	8.5

Latitude	50°		60°		70°		80°		90°	
	Long.	Lat.	Long.	Lat.	Long.	Lat.	Long.	Lat.	Long.	Lat.
Coordinates for plotting contours	180.0	81.5	0	88.5	0	78.5	0	68.5	All longitudes	58.5
	149.5	79.7	78.0	84.7	25.3	77.7	14.2	68.3		58.5
	133.9	75.6	90.4	79.7	46.5	75.7	28.0	67.7		58.5
	127.6	70.7	97.5	74.7	62.9	72.9	41.3	66.7		58.5
	125.7	65.6	103.3	69.8	75.9	69.7	53.8	65.4		58.5
	126.0	60.3	108.7	65.0	86.6	66.4	65.5	63.9		58.5
	127.6	55.2	113.9	60.3	95.8	62.9	76.4	62.3		58.5
	129.9	50.2	118.9	55.9	104.1	59.6	86.7	60.5		58.5
	132.9	45.4	124.1	51.6	111.9	56.3	96.5	58.8		58.5
	136.4	40.8	129.2	47.6	119.2	53.2	105.8	57.1		58.5
	140.2	36.5	134.5	43.9	126.2	50.4	114.8	55.5		58.5
	144.4	32.6	139.8	40.5	133.1	47.7	123.4	54.0		58.5
	148.8	29.0	145.3	37.4	139.9	45.4	131.9	52.6		58.5
	153.6	25.9	150.8	34.8	146.6	43.3	140.1	51.4		58.5
	158.5	23.3	156.5	32.6	153.3	41.6	148.2	50.4		58.5
	163.7	21.2	162.3	30.8	160.0	40.3	156.2	49.6		58.5
	169.1	19.7	168.1	29.5	166.6	39.3	164.2	49.0		58.5
	174.5	18.8	174.1	28.8	173.3	38.7	172.1	48.6		58.5
	180.0	18.5	180.0	28.5	180.0	38.5	180.0	48.5		58.5

27/48 3.5 MHz night

Data for plotting 4 000 km interference contours

Latitude	00°		10°		20°		30°		40°	
	Long.	Lat.	Long.	Lat.	Long.	Lat.	Long.	Lat.	Long.	Lat.
Coordinates for plotting contours	180.0	36.0	180.0	46.0	180.0	56.0	180.0	66.0	180.0	76.0
	172.8	35.4	171.7	45.3	169.7	55.1	166.1	64.9	157.6	74.5
	166.0	33.5	164.0	43.2	160.6	52.7	154.7	62.0	142.8	70.6
	160.0	30.6	157.5	39.9	153.4	49.0	146.6	57.7	134.9	70.6
	155.0	26.8	152.3	35.7	148.1	44.4	141.5	52.6	131.2	59.9
	150.9	22.2	148.4	30.8	144.5	39.2	138.7	47.0	129.9	54.0
	147.8	17.1	145.7	25.5	142.3	33.6	137.4	41.2	130.2	48.2
	145.7	11.6	144.1	19.8	141.4	27.7	137.4	35.4	131.6	42.4
	144.4	5.9	143.4	13.9	141.4	21.9	138.3	29.5	133.8	36.7
	144.0	0.0	143.6	8.1	142.3	16.1	140.0	23.9	136.5	31.3
	144.4	-5.9	144.6	2.3	143.9	10.4	142.4	18.4	139.8	26.2
	145.7	-11.6	146.4	-3.3	146.3	5.0	145.4	13.3	143.6	21.5
	147.8	-17.1	149.0	-8.6	149.4	0.0	149.0	8.6	147.8	17.2
	150.9	-22.2	152.4	-13.4	153.1	-4.5	153.2	4.4	152.4	13.3
	155.0	-26.8	156.6	-17.6	157.5	-8.4	157.8	0.8	157.4	10.1
	160.0	-30.6	161.6	-21.2	162.5	-11.6	162.9	-2.1	162.8	7.5
	166.0	-33.5	167.3	-23.8	168.0	-14.0	168.4	-4.2	168.3	5.6
	172.8	-35.4	173.5	-25.4	173.9	-15.5	174.1	-5.6	174.1	4.4
	180.0	-36.0	180.0	-26.0	180.0	-16.0	180.0	-6.0	180.0	4.0

Latitude	50°		60°		70°		80°		90°	
	Long.	Lat.	Long.	Lat.	Long.	Lat.	Long.	Lat.	Long.	Lat.
Coordinates for plotting contours	180.0	86.0	0	84.0	0	74.0	0	64.0	All longitudes	54.0
	126.9	82.7	46.5	81.9	20.9	73.4	13.4	63.8		54.0
	115.7	77.1	69.8	77.6	39.7	71.6	26.5	63.2		54.0
	113.9	71.3	83.0	72.8	55.5	69.1	39.2	62.3		54.0
	114.9	65.4	92.2	67.8	68.8	66.1	51.3	61.0		54.0
	117.1	59.6	99.7	62.8	80.1	62.8	62.8	59.6		54.0
	120.1	54.0	106.4	57.9	90.1	59.4	73.7	58.0		54.0
	123.5	48.5	112.6	53.2	99.0	56.0	84.1	56.3		54.0
	127.4	43.3	118.6	48.7	107.3	52.7	93.9	54.5		54.0
	131.5	38.3	124.5	44.5	115.2	49.5	103.4	52.8		54.0
	135.9	33.7	130.4	40.5	122.8	46.5	112.6	51.2		54.0
	140.7	29.4	136.3	36.9	130.1	43.7	121.5	49.6		54.0
	145.7	25.5	142.3	33.6	137.4	41.3	130.2	48.2		54.0
	150.9	22.1	148.4	30.8	144.5	39.1	138.7	47.0		54.0
	156.4	19.3	154.6	28.4	151.6	37.3	147.1	45.9		54.0
	162.1	17.0	160.8	26.5	158.7	35.9	155.4	45.1		54.0
	168.0	15.3	167.2	25.1	165.8	34.8	163.6	44.5		54.0
	174.0	14.3	173.6	24.3	172.9	34.2	171.8	44.1		54.0
	180.0	14.0	180.0	24.0	180.0	34.0	180.0	44.0		54.0



Data for plotting 1 200 km interference contours

Latitude	00°		10°		20°		30°		40°	
	Long.	Lat.	Long.	Lat.	Long.	Lat.	Long.	Lat.	Long.	Lat.
Coordinates for plotting contours	180.0	10.8	180.0	20.8	180.0	30.8	180.0	40.8	180.0	50.8
	178.1	10.6	178.0	20.6	177.8	30.6	177.5	40.6	177.1	50.6
	176.3	10.1	176.1	20.1	175.8	30.1	175.2	40.1	174.3	50.0
	174.6	9.3	174.3	19.3	173.8	29.2	173.1	39.2	171.8	49.1
	173.0	8.3	172.7	18.2	172.2	28.1	171.2	38.0	169.7	47.8
	171.7	6.9	171.4	16.8	170.3	26.7	169.7	36.5	168.0	46.4
	170.6	5.4	170.3	15.2	169.7	25.1	168.6	34.9	166.8	44.7
	169.8	3.7	169.6	13.5	168.9	23.3	167.9	33.1	166.1	42.9
	169.4	1.9	169.1	11.7	168.6	21.5	167.5	31.3	165.8	41.0
	169.2	0.0	169.0	9.8	168.5	19.6	167.6	29.4	166.0	39.2
	169.4	-1.9	169.3	8.0	168.8	17.8	168.0	27.6	166.6	37.3
	169.8	-3.7	169.8	6.2	169.4	16.0	168.7	25.8	167.5	35.6
	170.6	-5.4	170.6	4.5	170.4	14.4	169.8	24.2	168.7	34.0
	171.7	-6.9	171.7	3.0	171.5	12.9	171.0	22.8	170.2	32.6
	173.0	-8.3	173.1	1.7	172.9	11.6	172.6	21.5	171.9	31.4
	174.6	-9.3	174.6	0.6	174.5	10.6	174.3	20.5	173.8	30.5
	176.3	-10.1	176.3	-0.2	176.3	9.8	176.1	19.8	175.8	29.8
	178.1	-10.6	178.1	-0.6	178.1	9.4	178.0	19.3	177.9	29.3
	180.0	-10.8	180.0	-0.8	180.0	9.2	180.0	19.2	180.0	29.2

Latitude	50°		60°		70°		80°		90°	
	Long.	Lat.	Long.	Lat.	Long.	Lat.	Long.	Lat.	Long.	Lat.
Coordinates for plotting contours	180.0	60.8	180.0	70.8	180.0	80.8	0	89.2	All longitudes	79.2
	176.2	60.6	174.4	70.6	168.7	80.5	71.1	88.0		79.2
	172.6	60.0	169.3	69.8	159.4	79.5	87.5	86.3		79.2
	169.5	59.0	165.0	68.7	152.9	78.1	96.6	84.6		79.2
	167.0	57.6	161.8	67.3	149.1	76.4	103.6	82.9		79.2
	165.1	56.1	159.6	65.6	147.2	74.6	109.9	81.2		79.2
	163.8	54.4	158.4	63.8	146.8	72.8	115.8	79.6		79.2
	163.2	52.5	158.0	62.0	147.4	70.9	121.4	78.1		79.2
	163.1	50.7	158.3	60.1	148.9	69.1	126.9	76.7		79.2
	163.5	48.8	159.1	58.3	150.8	67.4	132.3	75.3		79.2
	164.3	47.0	160.4	56.6	153.3	65.8	137.7	74.1		79.2
	165.5	45.3	162.1	54.9	156.0	64.3	143.0	73.0		79.2
	167.0	43.8	164.2	53.5	159.1	63.0	148.3	72.0		79.2
	168.3	42.5	166.4	52.2	162.3	61.9	153.6	71.2		79.2
	170.3	41.3	168.9	51.2	165.7	60.9	158.9	70.5		79.2
	172.9	40.4	171.6	50.3	169.1	60.2	164.2	69.9		79.2
	175.8	39.7	174.3	49.7	172.7	59.6	169.4	69.5		79.2
	177.6	39.3	177.1	49.3	176.3	59.3	174.7	69.3		79.2
	180.0	39.2	180.0	49.2	180.0	59.2	180.0	69.2		79.2

27/50 4.7 MHz night and 10.0 MHz day

**Data for plotting 5 500 km interference contours**

Latitude	00°		10°		20°		30°		40°	
	Long.	Lat.	Long.	Lat.	Long.	Lat.	Long.	Lat.	Long.	Lat.
Coordinates for plotting contours	180.0	49.5	180.0	59.5	180.0	69.5	180.0	79.5	178.7	89.5
	168.5	48.5	165.5	58.2	159.6	67.8	144.9	76.7	97.0	82.4
	158.2	45.6	153.2	54.7	144.6	63.3	128.3	70.7	98.4	74.8
	149.7	41.2	144.1	49.6	135.4	57.2	121.5	63.5	101.0	67.2
	143.0	35.6	137.8	43.3	130.1	50.3	119.0	56.0	104.1	59.7
	138.1	29.3	133.6	36.5	127.3	43.0	118.6	48.4	107.5	52.4
	134.6	22.3	131.1	29.2	126.1	35.4	119.5	40.8	111.0	45.1
	132.3	15.1	129.8	21.6	126.1	27.8	121.2	33.4	114.8	38.1
	130.9	7.6	129.5	14.1	127.0	20.3	123.5	26.0	118.9	31.2
	130.5	0.0	130.1	6.5	128.7	12.8	126.5	18.9	123.2	24.7
	130.9	-7.6	131.5	-1.0	131.2	5.6	130.0	12.1	127.9	18.4
	132.3	-15.1	133.8	-8.2	134.4	-1.3	134.1	5.7	132.9	12.6
	134.6	-22.3	137.0	-15.2	138.3	-7.8	138.8	-0.3	138.4	7.3
	138.1	-29.3	141.2	-21.6	143.2	-13.7	144.2	-5.7	144.3	2.5
	143.0	-35.6	146.6	-27.4	148.9	-19.0	150.2	-10.4	150.7	-1.6
	149.7	-41.2	153.2	-32.4	155.5	-23.4	156.9	-14.2	157.6	-5.0
	158.2	-45.6	161.2	-36.2	163.1	-26.7	164.2	-17.1	164.8	-7.5
	168.5	-48.5	170.3	-38.7	171.3	-28.8	172.0	-18.9	172.3	-9.0
	180.0	-49.5	180.0	-39.5	180.0	-29.5	180.0	-19.5	180.0	-9.5

Latitude	50°		60°		70°		80°		90°	
	Long.	Lat.	Long.	Lat.	Long.	Lat.	Long.	Lat.	Long.	Lat.
Coordinates for plotting contours	0	80.5	0	70.5	0	60.5	0	50.5	All longitudes	40.5
	40.2	78.2	22.2	69.5	15.3	60.0	11.9	50.3		40.5
	63.5	73.1	41.5	66.9	30.1	58.7	23.8	49.8		40.5
	77.1	67.0	57.1	63.1	43.8	56.7	35.4	48.9		40.5
	86.6	60.7	69.8	58.6	56.4	54.0	46.7	47.8		40.5
	94.2	54.3	80.4	53.8	67.8	51.0	57.7	46.4		40.5
	100.8	47.9	89.6	48.8	78.4	47.8	68.3	44.9		40.5
	107.0	41.7	97.9	43.8	88.2	44.4	78.7	43.2		40.5
	112.9	35.6	105.7	38.9	97.5	41.0	88.7	41.5		40.5
	118.8	29.8	113.1	34.2	106.3	37.6	98.4	39.8		40.5
	124.7	24.4	120.4	29.8	114.8	34.4	108.0	38.1		40.5
	130.8	19.3	127.6	25.6	123.1	31.4	117.3	36.5		40.5
	137.1	14.7	134.8	21.9	131.3	28.7	126.5	35.0		40.5
	143.7	10.6	142.1	18.5	139.5	26.3	135.6	33.7		40.5
	150.5	7.1	149.5	15.7	147.6	24.3	144.5	32.6		40.5
	157.6	4.3	157.0	13.5	155.7	22.6	153.5	31.7		40.5
	164.9	2.2	164.6	11.8	163.8	21.5	162.3	31.0		40.5
	172.4	0.9	172.3	10.8	171.9	20.7	171.2	30.6		40.5
	180.0	0.5	180.0	10.5	180.0	20.5	180.0	30.5		40.5

Data for plotting 1 500 km interference contours

Latitude	00°		10°		20°		30°		40°	
	Long.	Lat.	Long.	Lat.	Long.	Lat.	Long.	Lat.	Long.	Lat.
Coordinates for plotting contours	180.0	13.5	180.0	23.5	180.0	33.5	180.0	43.5	180.0	53.5
	177.6	13.3	177.5	23.3	177.2	33.3	176.8	43.3	176.1	53.2
	175.3	12.7	175.0	22.6	174.6	32.6	173.8	42.5	172.5	52.5
	173.2	11.7	172.8	21.6	172.1	31.5	171.0	41.4	169.3	51.3
	171.2	10.3	170.8	20.2	170.0	30.0	168.7	39.9	166.6	49.6
	169.6	8.6	169.1	18.5	168.3	28.3	166.9	38.0	164.6	47.7
	168.3	6.7	167.8	16.5	167.0	26.2	165.5	36.0	163.2	45.6
	167.3	4.6	166.9	14.3	166.1	24.1	164.7	33.7	162.4	43.3
	166.7	2.3	166.4	12.1	165.7	21.8	164.4	31.4	162.3	41.0
	166.5	0.0	166.3	9.7	165.7	19.4	164.5	29.1	162.6	38.7
	166.7	-2.3	166.6	7.4	166.1	17.1	165.1	26.8	163.4	36.4
	167.3	-4.6	167.3	5.2	166.9	14.9	166.0	24.6	164.6	34.3
	168.3	-6.7	168.3	3.1	168.0	12.9	167.3	22.6	166.1	32.4
	169.6	-8.6	169.7	1.2	169.5	11.0	169.0	20.9	168.0	30.7
	171.2	-10.3	171.4	-0.4	171.2	9.5	170.8	19.3	170.1	29.2
	173.2	-11.7	173.3	-1.7	173.2	8.2	172.9	18.1	172.4	28.0
	175.3	-12.7	175.4	-2.7	175.4	7.3	175.2	17.2	174.8	27.2
	177.6	-13.3	177.7	-3.3	177.7	6.7	177.6	16.7	177.4	26.7
	180.0	-13.5	180.0	-3.5	180.0	6.5	180.0	16.5	180.0	26.5

Latitude	50°		60°		70°		80°		90°	
	Long.	Lat.	Long.	Lat.	Long.	Lat.	Long.	Lat.	Long.	Lat.
Coordinates for plotting contours	180.0	63.5	180.0	73.5	180.0	83.5	0	86.5	All longitudes	76.5
	174.8	63.2	172.0	73.1	160.8	82.9	35.2	86.0		76.5
	170.1	62.4	164.9	72.1	147.7	81.4	59.4	84.7		76.5
	166.1	61.0	159.4	70.6	140.7	79.4	75.5	83.1		76.5
	162.9	59.3	155.6	68.7	137.6	77.1	87.2	81.4		76.5
	160.7	57.3	153.3	66.5	137.0	74.8	96.7	79.6		76.5
	159.3	55.1	152.3	64.2	137.8	72.5	104.9	77.9		76.5
	158.7	52.8	152.3	61.9	139.6	70.2	112.4	76.3		76.5
	158.8	50.4	153.0	59.6	142.0	68.1	119.3	74.7		76.5
	159.5	48.1	154.4	57.4	144.9	66.0	125.9	73.3		76.5
	160.7	46.0	156.2	55.3	148.2	64.1	132.2	71.9		76.5
	162.3	43.9	158.4	53.3	151.7	62.4	138.4	70.7		76.5
	164.2	42.1	161.0	51.6	155.4	60.9	144.5	69.6		76.5
	166.4	40.4	163.8	50.1	159.3	59.6	150.5	68.7		76.5
	168.9	39.0	166.8	48.8	163.3	58.5	156.5	67.9		76.5
	171.5	37.9	170.0	47.8	167.4	57.6	162.4	67.3		76.5
	174.3	37.1	173.3	47.1	171.6	57.0	168.3	66.9		76.5
	177.1	36.7	176.6	46.6	175.8	56.6	174.1	66.6		76.5
	180.0	36.5	180.0	46.5	180.0	56.5	180.0	66.5		76.5

27/52 5.6 and 6.6 MHz night

Data for plotting 6 500 km interference contours

Latitude	00°		10°		20°		30°		40°	
	Long.	Lat.	Long.	Lat.	Long.	Lat.	Long.	Lat.	Long.	Lat.
Coordinates for plotting contours	180.0	58.5	180.0	68.5	180.0	78.5	180.0	88.5	0	81.5
	164.2	57.1	158.1	66.6	144.0	75.4	102.4	81.3	46.7	78.3
	150.8	53.2	142.2	61.6	126.6	68.7	100.1	72.8	68.5	71.7
	140.8	47.6	132.2	54.9	119.2	60.8	101.1	64.3	80.1	64.4
	133.6	40.8	126.2	47.2	116.0	52.4	102.9	55.8	88.0	56.7
	128.7	33.2	122.7	39.1	114.9	43.9	105.3	47.4	94.2	49.1
	125.3	25.2	120.8	30.7	115.1	35.4	108.0	39.1	99.7	41.5
	123.1	17.0	120.1	22.2	116.0	26.9	110.9	30.9	104.9	34.0
	121.9	8.5	120.2	13.7	117.7	18.5	114.3	22.9	110.0	26.7
	121.5	0.0	121.1	5.2	119.9	10.3	118.0	15.1	115.1	19.6
	121.9	-8.5	122.8	-3.2	122.8	2.3	122.1	7.6	120.5	12.9
	123.1	-17.0	125.2	-11.3	126.4	-5.5	126.8	0.5	126.3	6.5
	125.3	-25.2	128.6	-19.2	130.8	-12.8	132.0	-6.2	132.4	0.5
	128.7	-33.2	133.0	-26.7	136.1	-19.7	138.0	-12.3	139.0	-4.8
	133.6	-40.8	138.9	-33.5	142.5	-25.8	144.9	-17.7	146.2	-9.5
	140.8	-47.6	146.4	-39.5	150.2	-31.0	152.6	-22.2	154.0	-13.3
	150.8	-53.2	156.0	-44.3	159.1	-35.0	161.1	-25.6	162.3	-16.1
	164.2	-57.1	167.4	-47.4	169.2	-37.6	170.4	-27.8	171.0	-17.9
	180.0	-58.5	180.0	-48.5	180.0	-38.5	180.0	-28.5	180.0	-18.5

Latitude	50°		60°		70°		80°		90°	
	Long.	Lat.	Long.	Lat.	Long.	Lat.	Long.	Lat.	Long.	Lat.
Coordinates for plotting contours	0	71.5	0	61.5	0	51.5	0	41.5	All longitudes	31.5
	25.7	70.1	17.6	60.7	13.6	51.1	11.4	41.3		31.5
	46.4	66.2	34.0	58.6	26.9	49.9	22.7	40.8		31.5
	61.7	61.0	43.4	55.3	39.6	48.0	33.8	40.0		31.5
	73.3	55.1	61.0	51.2	51.6	45.6	44.8	38.9		31.5
	82.7	48.8	71.9	46.6	62.8	42.7	55.5	37.6		31.5
	90.7	42.4	81.7	41.7	73.8	39.6	66.0	36.1		31.5
	98.0	36.0	90.6	36.7	83.2	36.2	76.2	34.4		31.5
	104.8	29.7	99.0	31.8	92.7	32.8	86.2	32.7		31.5
	111.6	23.6	107.0	26.9	101.8	29.4	96.1	31.0		31.5
	115.1	17.8	114.9	22.2	110.7	26.1	105.7	29.3		31.5
	124.9	12.3	122.7	17.9	119.5	23.0	115.3	27.6		31.5
	131.8	7.3	130.5	13.8	128.1	20.2	124.7	26.1		31.5
	139.2	2.7	138.4	10.3	136.7	17.7	134.0	24.9		31.5
	146.8	-1.1	146.5	7.2	145.3	15.5	143.3	23.6		31.5
	154.7	-4.3	154.7	4.8	154.0	13.8	152.5	22.7		31.5
	162.9	-6.6	163.0	3.0	162.6	12.5	161.7	22.1		31.5
	171.4	-8.0	171.5	1.9	171.3	11.8	170.8	21.6		31.5
	180.0	-8.5	180.0	1.5	180.0	11.5	180.0	21.5		31.5

Data for plotting 1 900 km interference contours

Latitude	00°		10°		20°		30°		40°	
	Long.	Lat.	Long.	Lat.	Long.	Lat.	Long.	Lat.	Long.	Lat.
Coordinates for plotting contours	180.0	17.1	180.0	27.1	180.0	37.1	180.0	47.1	180.0	57.1
	176.9	16.8	176.7	26.8	176.3	36.8	175.7	46.8	174.7	56.7
	174.0	16.0	173.6	26.0	172.9	35.9	171.7	45.8	169.7	55.7
	171.3	14.8	170.7	24.6	169.7	34.5	168.1	44.3	165.5	54.0
	168.8	13.0	168.2	22.8	167.0	32.6	165.2	42.3	162.2	51.9
	166.7	10.9	166.1	20.6	164.9	30.3	162.9	39.9	159.8	49.4
	165.1	8.5	164.5	18.1	163.3	27.7	161.3	37.2	158.2	46.6
	163.9	5.8	163.3	15.4	162.3	24.9	160.4	34.4	157.5	43.7
	163.1	2.9	162.7	12.5	161.8	22.0	160.2	31.5	157.5	40.8
	162.9	0.0	162.7	9.6	161.9	19.1	160.4	28.5	158.1	37.9
	163.1	-2.9	163.1	6.6	162.4	16.2	161.3	25.7	159.3	35.1
	163.9	-5.8	163.9	3.8	163.5	13.4	162.5	23.0	160.9	32.5
	165.1	-8.5	165.2	1.2	165.0	10.9	164.2	20.5	162.9	30.1
	166.7	-10.9	167.0	-1.2	166.8	8.6	166.3	18.3	165.2	28.0
	168.8	-13.0	169.1	-3.2	169.0	6.6	168.6	16.4	167.8	26.2
	171.3	-14.8	171.5	-4.9	171.5	5.0	171.2	14.9	170.7	24.8
	174.0	-16.0	174.2	-6.1	174.2	3.9	174.1	13.8	173.7	23.7
	176.9	-16.8	177.1	-6.8	177.1	3.1	177.0	13.1	176.8	23.1
	180.0	-17.1	180.0	-7.1	180.0	2.9	180.0	12.9	180.0	22.9

Latitude	50°		60°		70°		80°		90°	
	Long.	Lat.	Long.	Lat.	Long.	Lat.	Long.	Lat.	Long.	Lat.
Coordinates for plotting contours	180.0	67.1	180.0	77.1	180.0	87.1	0	82.9	All longitudes	72.9
	172.6	66.7	167.3	76.5	137.0	85.7	23.2	82.5		72.9
	166.0	65.5	157.1	75.0	123.8	83.1	43.5	81.6		72.9
	160.7	63.6	150.3	72.8	120.8	80.1	60.0	80.2		72.9
	156.8	61.3	146.2	70.1	121.4	77.2	73.5	78.6		72.9
	154.4	58.6	144.4	67.3	123.5	74.3	84.9	76.9		72.9
	153.1	55.8	144.0	64.3	126.5	71.5	94.8	75.2		72.9
	152.8	52.8	144.7	61.4	130.1	68.8	103.6	73.5		72.9
	153.3	49.9	146.3	58.6	133.9	66.3	111.8	71.8		72.9
	154.4	47.1	148.4	55.9	138.0	63.9	119.4	70.3		72.9
	156.1	44.4	151.0	53.3	142.3	61.7	126.8	68.8		72.9
	158.2	41.9	153.9	51.0	146.7	59.7	133.8	67.5		72.9
	160.7	39.6	157.2	49.0	151.3	58.0	140.7	66.3		72.9
	163.5	37.6	160.7	47.2	155.9	56.5	147.4	65.3		72.9
	166.5	36.0	164.3	45.7	160.7	55.2	154.0	64.4		72.9
	169.7	34.6	168.1	44.5	165.4	54.2	160.6	63.8		72.9
	173.1	33.7	172.0	43.6	170.3	53.5	167.1	63.3		72.9
	176.5	33.1	176.0	43.1	175.1	53.0	173.5	63.0		72.9
	180.0	32.9	180.0	42.9	180.0	52.9	180.0	62.9		72.9

27/54 9.0 MHz day

Data for plotting 3 800 km interference contours

Latitude	00°		10°		20°		30°		40°	
	Long.	Lat.	Long.	Lat.	Long.	Lat.	Long.	Lat.	Long.	Lat.
Coordinates for plotting contours	180.0	34.2	180.0	44.2	180.0	54.2	180.0	64.2	180.0	74.2
	173.3	33.6	172.3	43.5	170.6	53.4	167.5	63.2	160.6	72.9
	166.9	31.9	165.1	41.6	162.1	51.2	157.0	60.6	146.8	69.4
	161.2	29.1	158.9	38.5	155.3	47.8	149.3	56.6	138.8	64.8
	156.4	25.5	154.0	34.6	150.2	43.4	144.2	51.9	134.6	59.5
	152.5	21.2	150.2	30.0	146.6	38.5	141.2	46.6	133.0	53.9
	149.5	16.3	147.6	24.9	144.4	33.2	139.8	41.1	132.9	48.3
	147.4	11.1	145.9	19.4	143.4	27.6	139.6	35.5	134.0	42.8
	146.2	5.6	145.2	13.9	143.3	22.0	140.3	29.9	135.9	37.3
	145.8	0.0	145.4	8.3	144.1	16.4	141.9	24.4	138.4	32.1
	146.2	-5.6	146.3	2.7	145.7	11.0	144.1	19.2	141.5	27.2
	147.4	-11.1	148.1	-2.6	147.9	5.9	147.0	14.3	145.1	22.6
	149.5	-16.3	150.6	-7.7	150.9	1.1	150.4	9.8	149.1	18.4
	152.5	-21.2	153.9	-12.3	154.5	-3.2	154.4	5.8	153.6	14.8
	156.4	-25.5	157.9	-16.3	158.7	-7.0	158.8	2.3	158.4	11.6
	161.2	-29.1	162.6	-19.6	163.4	-10.1	163.7	-0.5	163.5	9.1
	166.9	-31.9	168.0	-22.1	168.7	-12.3	168.9	-2.5	168.8	7.3
	173.3	-33.6	173.9	-23.7	174.2	-13.7	174.4	-3.8	174.4	6.2
	180.0	-34.2	180.0	-24.2	180.0	-14.2	180.0	-4.2	180.0	5.8

Latitude	50°		60°		70°		80°		90°	
	Long.	Lat.	Long.	Lat.	Long.	Lat.	Long.	Lat.	Long.	Lat.
Coordinates for plotting contours	180.0	84.2	0	85.8	0	75.8	0	65.8	All longitudes	55.8
	137.8	81.6	56.0	83.2	22.4	75.1	13.7	65.6		55.8
	123.5	76.7	77.1	78.6	42.0	73.3	27.0	65.0		55.8
	119.5	71.2	88.4	73.7	58.2	70.7	39.9	64.0		55.8
	119.2	65.6	96.4	68.7	71.4	67.6	52.2	62.8		55.8
	120.6	60.0	103.2	63.8	82.5	64.3	63.8	61.3		55.8
	123.0	54.5	109.3	59.0	92.2	60.8	74.7	59.7		55.8
	126.0	49.2	115.1	54.3	101.0	57.5	85.1	58.0		55.8
	129.5	44.1	120.7	49.9	109.1	54.2	94.9	56.2		55.8
	133.4	39.3	126.3	45.7	116.7	51.0	104.3	54.5		55.8
	137.6	34.8	132.0	41.9	124.1	48.1	113.4	52.9		55.8
	142.1	30.7	137.7	38.3	131.3	45.4	122.2	51.4		55.8
	146.9	26.9	143.5	35.2	138.3	42.9	130.8	50.0		55.8
	152.0	23.7	149.3	32.4	145.3	40.8	139.2	48.7		55.8
	157.2	20.9	155.3	30.1	152.3	39.0	147.5	47.7		55.8
	162.7	18.7	161.4	28.2	159.2	37.6	155.7	46.9		55.8
	168.4	17.1	167.6	26.9	166.1	36.6	163.8	46.3		55.8
	174.2	16.1	173.3	26.1	173.1	36.0	171.9	45.9		55.8
	180.0	15.8	180.0	25.8	180.0	35.8	180.0	45.8		55.8

Data for plotting 6 000 km interference contours

Latitude	00°		10°		20°		30°		40°	
	Long.	Lat.	Long.	Lat.	Long.	Lat.	Long.	Lat.	Long.	Lat.
Coordinates for plotting contours	180.0	54.0	180.0	64.0	180.0	74.0	180.0	84.0	0	86.0
	166.6	52.8	162.3	62.5	153.3	71.8	128.2	79.7	66.2	81.2
	154.8	49.5	148.2	58.3	136.6	66.3	115.0	72.2	82.1	73.8
	145.5	44.5	138.5	52.4	127.7	59.3	111.4	64.2	90.0	66.1
	138.5	38.3	132.2	45.4	123.2	51.6	111.0	58.2	95.7	58.5
	133.5	31.3	128.2	37.9	121.1	43.6	111.9	48.1	100.6	50.9
	130.0	23.9	126.0	30.0	120.6	35.5	113.6	40.1	105.2	43.4
	127.7	16.1	124.9	22.0	121.1	27.5	116.0	32.2	109.7	36.1
	126.4	8.1	124.8	13.9	122.3	19.5	118.8	24.6	114.3	29.0
	126.0	0.0	125.6	5.9	124.3	11.6	122.2	17.1	119.1	22.2
	126.4	-8.1	127.1	-2.1	127.0	4.0	126.0	9.9	124.2	15.7
	127.7	-16.1	129.5	-9.8	130.4	-3.4	130.4	3.1	129.6	9.5
	130.0	-23.9	132.8	-17.2	134.6	-10.3	135.4	-3.2	135.4	3.9
	133.5	-31.3	137.2	-24.2	139.7	-16.7	141.1	-9.0	141.7	-1.2
	138.5	-38.3	142.9	-30.5	145.8	-22.4	147.6	-14.1	148.5	-5.6
	145.5	-44.5	150.0	-36.0	152.9	-27.2	154.8	-18.2	155.6	-9.1
	154.8	-49.5	158.7	-40.3	161.2	-30.9	162.7	-21.4	163.6	-11.8
	166.6	-52.8	163.9	-43.0	170.3	-33.2	171.2	-23.3	171.7	-13.4
	180.0	-54.0	180.0	-44.0	180.0	-34.0	180.0	-24.0	180.0	-14.0

Latitude	50°		60°		70°		80°		90°	
	Long.	Lat.	Long.	Lat.	Long.	Lat.	Long.	Lat.	Long.	Lat.
Coordinates for plotting contours	0	76.0	0	66.0	0	56.0	0	46.0	All longitudes	36.0
	31.1	74.2	19.5	65.1	14.4	55.6	11.6	45.8		36.0
	53.5	69.9	37.2	62.8	28.3	54.3	23.2	45.3		36.0
	68.6	64.2	52.3	59.2	41.5	52.4	34.5	44.5		36.0
	79.4	58.1	65.0	55.0	53.7	49.8	45.7	43.4		36.0
	88.1	51.7	75.8	50.3	65.1	46.9	56.5	42.0		36.0
	95.5	45.3	85.4	45.3	75.7	43.7	67.1	40.5		36.0
	102.3	38.9	94.1	40.3	85.6	40.3	77.4	38.3		36.0
	108.7	32.7	102.2	35.4	95.0	36.9	87.4	37.1		36.0
	115.0	26.3	110.0	30.6	104.0	33.5	97.2	35.4		36.0
	121.4	21.1	117.5	26.0	112.7	30.3	106.8	33.7		36.0
	127.8	15.8	125.1	21.8	121.2	27.2	116.2	32.1		36.0
	134.5	11.0	132.6	17.9	129.7	24.5	125.5	30.6		36.0
	141.4	6.7	140.2	14.4	138.1	22.0	134.7	29.2		36.0
	148.6	3.0	148.0	11.5	146.4	19.9	143.9	28.1		36.0
	156.1	-0.0	155.8	9.1	154.8	18.2	152.9	27.2		36.0
	163.9	-2.2	163.8	7.4	163.2	17.0	162.0	26.5		36.0
	171.0	-3.5	171.9	6.4	171.6	16.3	171.0	26.1		36.0
	180.0	-4.0	180.0	6.0	180.0	16.0	180.0	26.0		36.0

## C – Classes of emission and power

### 1 Classes of emission

27/56 In the aeronautical mobile (R) service the use of emissions listed below is permissible subject to compliance with the special provisions applicable to each case and provided that such use does not cause harmful interference to other users of the channel concerned.

#### 27/57 1.1 Telephony – amplitude modulation:

- double sideband A3E\*
- single sideband, full carrier H3E\*
- single sideband, suppressed carrier J3E

#### 1.2 Telegraphy (including automatic data transmission)

##### 27/58 1.2.1 Amplitude modulation:

- telegraphy without the use of a modulating audio frequency (by on-off keying) A1A, A1B\*\*
- telegraphy by the on-off keying of an amplitude modulating audio frequency or audio frequencies or by the on-off keying of the modulated emission and including selective calling, single sideband, full carrier H2B
- multichannel voice frequency telegraphy, single sideband, suppressed carrier J7B
- other transmissions such as automatic data transmission, single sideband, suppressed carrier JXX

##### 27/59 1.2.2 Frequency modulation:

- telegraphy by frequency shift keying without the use of a modulating audio frequency, one of two frequencies being emitted at any instant F1B\*\*

---

\* A3E and H3E to be used only on 3 023 kHz and 5 680 kHz.

\*\* A1A, A1B and F1B are permitted provided they do not cause harmful interference to the classes of emission H2B, J3E, J7B and JXX. In addition, A1A, A1B and F1B emissions shall be in accordance with the provisions in Nos. 27/70 to 27/74 and care should be taken to place these emissions at or near the centre of the channel. However, a modulating audio frequency is permitted with single sideband transmitters, where the carrier is suppressed in accordance with No. 27/69.



## 2 Power

27/60 2.1 Unless otherwise specified in Part II of this Appendix, the peak envelope powers supplied to the antenna transmission line shall not exceed the maximum values indicated in the Table below; the corresponding peak effective radiated powers being assumed to be equal to two-thirds of these values.

Class of emission	Stations	Maximum peak envelope power
H2B, J3E, J7B, JXX A3E*, H3E* (100% modulation)	Aeronautical stations Aircraft stations	6 kW 400 W
Other emissions such as A1A, A1B, F1B	Aeronautical stations Aircraft stations	1.5 kW 100 W

\* A3E and H3E to be used only on 3 023 kHz and 5 680 kHz.

27/61 2.2 It is assumed that the maximum peak envelope powers specified above for aeronautical stations will produce the mean effective radiated power of 1 kW used as a basis for the interference range contours.

27/62 2.3 In order to provide satisfactory communication with aircraft, aeronautical stations serving MWARA, VOLMET and world-wide allotment areas may exceed the power limits specified in No. 27/60, except in the case of 3 023 kHz and 5 680 kHz which are subject to the special provisions of Nos. 27/232 to 27/238. In each such case, the administration having jurisdiction over the aeronautical station shall note No. 15.2 and ensure:

- 27/63 a) that when there is any possibility of harmful interference coordination is effected with the administrations concerned;
- 27/64 b) that harmful interference is not caused to stations using frequencies in accordance with the applicable provisions of the allotment Plan;
- 27/65 c) that in other MWARAs, RDARAs or VOLMET areas allotted the same frequencies, the specified protection ratios within the boundaries of those areas shall be maintained;
- 27/66 d) that the directional characteristics of the antenna are such as to minimize radiation in unnecessary directions, particularly towards other MWARAs, RDARAs or VOLMET areas which have been allotted the same frequencies;
- 27/67 e) that, in accordance with the Radio Regulations, all details of the assignment(s), including the transmitting antenna characteristics shall be notified to the Radiocommunication Bureau.

27/68 2.4 It is recognized that the power employed by aircraft transmitters may, in practice, exceed the limits specified in No. 27/60. However, the use of such increased power (which normally should not exceed 600 W PX) shall not cause harmful interference to stations using frequencies in accordance with the technical principles on which the allotment Plan is based.

## D – Limits to the power levels of unwanted emissions

### 1 Technical provisions relating to the use of single-sideband emissions

#### 27/69 1.1 Definitions carrier modes:

Carrier mode	Level $N$ (dB) of the carrier with respect to peak envelope power
Full carrier (for example H2B)	$0 \geq N \geq -6$
Suppressed carrier (for example J3E)	Aircraft stations $N < -26$ Aeronautical stations $N < -40$

### 2 Tolerance for levels of emission outside the necessary bandwidth

27/70 2.1 In a single-sideband transmission, the mean power of any emission supplied to the antenna transmission line of an aeronautical or aircraft station on any discrete frequency, shall be less than the mean power (PY) of the transmitter in accordance with the Table in No. 27/71.

27/71 2.2 For aircraft station transmitter types first installed before 1 February 1983:

Frequency separation $\Delta$ from the assigned frequency (kHz)	Minimum attenuation below mean power (PY) (dB)
$2 \leq \Delta < 6$	25
$6 \leq \Delta < 10$	35
$10 \leq \Delta$	Aircraft stations: 40 Aeronautical stations: $43 + 10 \log_{10} (PY) (W)$

27/72 NOTE – All transmitters first placed in operation after 1 February 1983 shall comply with the specifications contained in No. 27/74.

27/73 2.3 In a single-sideband transmission, the peak envelope power (PX) of any emission supplied to the antenna transmission line of an aeronautical or aircraft station on any discrete frequency, shall be less than the peak envelope power (PX) of the transmitter in accordance with the Table in No. 27/74.

27/74 2.4 For aircraft station transmitters first installed after 1 February 1983 and for aeronautical station transmitters in use after 1 February 1983:

Frequency separation $\Delta$ from the assigned frequency (kHz)	Minimum attenuation below peak envelope power (PX) (dB)
$1.5 \leq \Delta < 4.5$	30
$4.5 \leq \Delta < 7.5$	38
$7.5 \leq \Delta$	Aircraft stations: 43 Aeronautical stations: *

\* For transmitter power up to and including 50 W:  $43 + 10 \log_{10} (PX)$  (W). For transmitter powers more than 50 W, the attenuation shall be at least 60 dB.

## E – Other technical provisions

### 1 Assigned frequencies

27/75 1.1 For single-sideband emissions, except the class of emission H2B, the assigned frequency shall be at a value 1 400 Hz above the carrier (reference) frequency.

27/76 1.2 For aeronautical stations equipped with selective calling systems, the class of emission H2B shall be indicated in the Supplementary Information column of the form of notice (see Appendix 4).

27/77 1.3 For classes of emission A1A, A1B and F1B the assigned frequency shall be chosen in accordance with the provisions of the footnote to Nos. 27/58 and 27/59.

27/78 1.4 The assigned frequency of a station employing double sideband emissions (A3E) shall be at the carrier (reference) frequency.

**PART II – Plan for the allotment of frequencies for the aeronautical mobile (R)  
service in the exclusive bands between 2850 and 22000 kHz**

**Section I – Description of the boundaries of the areas and sub-areas**

- 27/79        1        The boundary descriptions which follow delineate the areas to which frequencies are allotted under the frequency allotment Plan.
- 27/80        2        These areas are shown graphically on the maps associated with this Appendix. If there is any difference between the areas as shown on the maps and as described, the written description is to be considered correct.
- 27/81        3        References to the name of a country or of a geographical area in the descriptions or on the maps and the borders shown on the maps do not imply the expression of any opinion whatsoever on the part of the ITU concerning the political status of such a country or geographical area or any official recognition of these borders.
- 27/82        4        In the description of the Major World Air Route Areas (MWARAs) all lines between points not otherwise specified are defined as great circles.
- 27/83               In the description of the Regional and Domestic Air Route Areas (RDARAs) and Sub-Areas all lines between points not otherwise specified are defined as straight lines on a Mercator Projection map.
- 27/84               In the description of the VOLMET areas all lines between points are defined as great circles.

**ARTICLE 1**

**Description of the boundaries of the major world air route areas  
(MWARAs)**

27/85        *Major World Air Route Area – CARIBBEAN (MWARA-CAR)*

From the point 20° N 120° W through the points 35° N 120° W, 35° N 85° W, 43° N 74° W, 40° N 60° W, 00° 48° W, 00° 80° W, to the point 20° N 120° W.

27/86        *Major World Air Route Area – CENTRAL EAST PACIFIC (MWARA-CEP)*

From the point 50° N 122° W through the points 38° N 120° W, 15° N 110° W, 20° S 145° W, 20° S 152° W, 30° N 165° W, to the point 50° N 122° W.

27/87        *Major World Air Route Area – CENTRAL WEST PACIFIC (MWARA-CWP)*

From the point 40° N 117° E through the points 25° N 155° W, 17° N 155° W, 00° 165° W, 00° 170° E, 12° S 165° E, 12° S 136° E, 09° N 115° E, 23° N 114° E, to the point 40° N 117° E.

## AP27-26

### 27/88 *Major World Air Route Area – EUROPE (MWARA-EUR)*

From the point 33° N 12° W through the points 54° N 12° W, 70° N 00°, 74° N 40° E, 74° N 52° E, 60° N 52° E, 40° N 36° E, 29° N 35° 30' E, 32° N 13° E, to the point 33° N 12° W.

### 27/89 *Major World Air Route Area – INDIAN OCEAN (MWARA-INO)*

From the South Pole through the points 30° S 26° E, 20° N 35° E, 30° N 60° E, 30° N 90° E, 30° S 120° E, 40° S 160° E to the South Pole.

### 27/90 *Major World Air Route Area – MIDDLE EAST (MWARA-MID)*

From the point 51° N 30° E through the points 57° N 37° E, 50° N 80° E, 44° N 94° E, 08° N 76° E, 11° 45' N 42° E, 16° N 42° E, 30° N 30° E, to the point 51° N 30° E.

### 27/91 *Major World Air Route Area – NORTH ATLANTIC (MWARA-NAT)*

From the North Pole through the points 60° N 135° W, 49° N 120° W, 49° N 74° W, 39° N 78° W, 18° N 66° W, 05° N 55° W, 16° N 26° W, 32° N 08° W, 44° N 02° E, 60° N 20° E, to the North Pole.

### 27/92 *Major World Air Route Area – NORTH CENTRAL ASIA (MWARA-NCA)*

From the North Pole through the points 75° N 10° E, 60° N 25° E, 30° N 25° E, 30° N 73° E, 37° N 73° E, 49° N 85° E, 42° N 97° E, 42° N 110° E, 45° N 113° E, 46° 30' N 120° E, 49° N 116° E, 54° N 123° E, 45° N 133° E, 40° N 124° E, 30° N 124° E, 25° N 135° E, 65° N 170° W, to the North Pole.

### 27/93 *Major World Air Route Area – NORTH PACIFIC (MWARA-NP)*

From the North Pole through the points 60° N 135° W, 47° N 118° W, 30° N 165° W, 30° N 115° E, 41° N 116° E, 55° N 135° E to the North Pole.

### 27/94 *Major World Air Route Area – AFRICA (MWARA-AFI)*

From the point 40° N 35° W, through the points 37° N 03° W, 37° N 44° E, the border between Iraq and the Islamic Republic of Iran, the points 29° N 48° E, 26° N 56° E, 20° N 62° E, 22° S 60° E, 35° S 30° E, 35° S 16° E, 05° N 03° W, 05° N 35° W, to the point 40° N 35° W.

### 27/95 *Major World Air Route Area – SOUTH ATLANTIC (MWARA-SAT)*

From the South Pole through the points 30° S 75° W, 19° S 53° W, 00° 60° W, 20° N 60° W, 25° N 25° W, 41° N 15° W, 41° N 03° W, 15° N 03° W, 20° S 32° E to the South Pole.

### 27/96 *Major World Air Route Area – SOUTH AMERICA (MWARA-SAM)*

From the South Pole through the points 15° N 125° W, 15° N 60° W, 10° N 60° W, 05° S 30° W, 36° S 52° W, to the South Pole.

27/97 *Major World Air Route Area – SOUTH EAST ASIA (MWARA-SEA)*

From the point 26° N 130° E, through the points 00° 130° E, 00° 135° E, 12° S 145° E, 12° S 160° E, 25° S 155° E, 40° S 150° E, 35° S 115° E, 18° N 62° E, 26° N 65° E, to the point 26° N 130° E.

27/98 *Major World Air Route Area – SOUTH PACIFIC (MWARA-SP)*

From the South Pole through the points 38° S 145° E, 00° 167° E, 00° 175° W, 22° N 158° W, 22° N 156° W, 00° 120° W to the South Pole.

27/99 *Major World Air Route Area – EAST ASIA (MWARA-EA)*

From the point 55° N 124° E through the points 37° N 145° E, 26° N 130° E, 00° 130° E, 00° 80° E, 18° N 62° E, 37° N 67° E, 55° N 80° E to the point 55° N 124° E.

## ARTICLE 2

### **Description of the boundaries of the regional and domestic air route areas (RDARAs)**

27/100 *Regional and Domestic Air Route Area – 1 (RDARA-1)*

From the North Pole along the 15° W meridian to the point 72° N 15° W, then through the points 40° N 50° W, 30° N 39° W, 30° N 10° W, 31° N 10° W, to the point 31° N 10° E. Then along the Libya-Tunisia border to the Mediterranean, thence along the coast of Libya and Egypt to Alexandria. Thence to Cairo, eastward along the Cairo parallel to intersect the 40° E meridian, and north along the 40° E meridian to the intersection with the border between the Syrian Arabic Republic and Iraq and along this border up to the Turkish border. Then along the border between Turkey and the following countries: Iraq, Islamic Republic of Iran, Armenia and Georgia, up to the Black Sea Coast. Thence along the Black Sea Coast of Turkey to intersect the 30° E meridian, then along the 30° E meridian to the border of Romania and Ukraine. Thence along the borders between Romania and Ukraine, Romania and Moldova, Romania and Ukraine. Thence along the border of Ukraine, and the following countries: Hungary, Slovakia and Poland. Thence along the border of Poland and the following countries: Belarus, Lithuania and the Russian Federation. Thence northeastward along the Baltic Sea coast, to the border between Finland and the Russian Federation, and between Norway and the Russian Federation, to the point 70° N 32° E, and along the 32° E meridian to the North Pole.

27/101 *Sub-Area 1A*

From the point 65° N 26° W, and through the points 40° N 50° W, 40° N 20° W, 60° N 20° W, 60° N 26° W, to the point 65° N 26° W.

27/102 *Sub-Area 1B*

From the North Pole along the 15° W meridian to the point 72° N 15° W, then through the points 65° N 26° W, 60° N 26° W, 60° N 20° W to the points 50° N 20° W and 50° N 10° W, thence east along the territorial waters between the Channel Islands and the French coastline, reaching the latter at the meridian 03° W. Thence following the French coastline northeastward and the frontier of France with Belgium, Luxembourg and Germany. Thence along the border between Germany and the following countries: Switzerland, Austria, the Czech Rep. and Poland towards the Baltic Sea. Then west along the coastline of Germany to the border between the latter and Denmark. Along this border to the North Sea. Thence along the 55° N parallel to the point 55° N 04° E, then through the points 56° N 03° E, 59° N 02° E, 62° N 01° E. Thence along the 01° E meridian to the North Pole.

27/103 *Sub-Area 1C*

From the North Pole along the meridian 01° E to the point 62° N 01° E. Thence through the points 59° N 02° E, 56° N 03° E, 55° N 04° E and then east along the 55° N parallel and the border between Denmark and Germany to the Baltic Sea and along the Baltic Sea coast of Germany to the border between Germany and Poland. Along this border and continuing along the western borders of the Czech Rep. and Austria to the borders between Austria and Switzerland, Austria and Liechtenstein and Austria and Switzerland. Thence eastward along the southern borders of Austria and Hungary, thence along the border between Hungary and Romania. Thence, along the border between Ukraine and the following countries: Hungary, Slovakia and Poland. Thence along the border of Poland and the following countries: Belarus, Lithuania and the Russian Federation to the Baltic Sea. Thence northeastward along the Baltic Sea coast, along the borders between Finland and the Russian Federation and between Norway and the Russian Federation to the point 70° N 32° E, then along the 32° E meridian to the North Pole.

27/104 *Sub-Area 1D*

From the junction of the borders of Ukraine, Hungary and Romania, westward along the southern borders of Hungary and Austria to the border between Switzerland and Italy, and the border between France and Italy to the Mediterranean Sea. Thence to 43° N 10° E to 41° N 10° E to 41° N 07° E, thence along the 07° E meridian to the North African coast. Then along the North African coast including Tunis, Tripoli, Benghazi, to the coastal border between Libya and Egypt. Thence along the coast to Alexandria, then to Cairo, and along the Cairo parallel to the 40° E meridian. North along the 40° E meridian to the intersection with the border between Syrian Arab Republic and Iraq and along this border up to the Turkish border. Then along the border between Turkey and the following countries: Iraq, Islamic Republic of Iran, Armenia and Georgia, up to the Black Sea Coast. Thence along the Black Sea Coast of Turkey to intersect the 30° E meridian. Along the 30° E meridian to the border of Romania and Ukraine, thence along the borders between Romania and Ukraine, Romania and Moldova, Romania and Ukraine to the junction of the borders of Ukraine, Hungary and Romania.

27/105 *Sub-Area 1E*

From the point 50° N 20° W, through the points 40° N 20° W, 40° N 50° W, 30° N 39° W, 30° N 10° W, 31° N 10° W, to the point 31° N 10° E. Then along the border between Libya and Tunisia to the Mediterranean, thence along the Tunisian coast to intersect the 10° E meridian. Thence along this meridian to the point 43° N 10° E; thence to the borders between Italy and France and between Italy and Switzerland, Austria and Switzerland, Austria and Liechtenstein, Austria and Switzerland, Switzerland and Germany, and between France and Germany, France and Luxembourg, and France and Belgium to the Channel coast. Thence west through the territorial waters between the Channel Islands and the French coast to the points 50° N 10° W and 50° N 20° W.

27/106 *Regional and Domestic Air Route Area – 2 (RDARA-2)*

From the North Pole along the 32° E meridian to the 70° N parallel. Then along the border between Norway and the Russian Federation and Finland and the Russian Federation to the Baltic coast. Thence southwestward along the Baltic coast to the border between the Russian Federation and Poland. Thence along the border between Poland and the following countries: the Russian Federation, Lithuania, Belarus and Ukraine. Thence along the border between Ukraine and the following countries: Poland, Slovakia, Hungary and Romania, to the junction of the borders of Ukraine, Romania and Moldova. Thence along the borders of Romania and Moldova, Romania and Ukraine, to the Black Sea coast at the intersection of the 30° E meridian. Then along the 30° E meridian to the Black Sea coast of Turkey. Along the Black Sea coast of Turkey to the junction of the borders of Turkey and Georgia. Thence along borders between Turkey and the following countries: Georgia, Armenia and Azerbaijan, to the junction of the borders between the Islamic Republic of Iran and Azerbaijan. Then along the northern border of the Islamic Republic of Iran to Caspian Sea. Then along the Iran Caspian Sea coast to the border of Turkmenistan. Thence eastward along the southern borders of Turkmenistan, Uzbekistan, Tajikistan and Kyrgyzstan, and the eastern border of Kazakhstan, to the junction of the borders of Kazakhstan, the Russian Federation and China. Then along the border between the Russian Federation and China to the intersection of the Mongolia-China-Russian Federation borders at approximately 49° N 88° E. Then along the 88° E meridian to 55° N. Then along the 55° N parallel to 60° E, and along the 60° E meridian to the North Pole.

27/107 *Sub-Area 2A*

From the North Pole along the 32° E meridian to 70° N. Then along the border between Norway and the Russian Federation, and Finland and the Russian Federation to the Baltic coast, and southwestward along the Baltic coast to the point 55° N 20° E, and thence to Moscow. Then to 55° N 60° E, and along the 60° E meridian to the North Pole.

27/108 *Sub-Area 2B*

From the point 55° N 88° E and through the point 55° N 60° E to the point 47° N 53° E. Thence along the east coast of the Caspian Sea to the Iranian coast. Then along the Islamic Republic of Iran Caspian Sea coast to the border of Turkmenistan. Thence eastward along the southern borders of Turkmenistan, Uzbekistan, Tajikistan and Kyrgyzstan, and the eastern border of Kazakhstan, to the junction of the borders of Kazakhstan, the Russian Federation and China. Then along the border between the Russian Federation and China to the intersection of the Mongolia-China-Russian Federation borders at approximately 49° N 88° E; thence along the 88° E meridian to 55° N 88° E.



## AP27-30

### 27/109 *Sub-Area 2C*

From the point 55° N 60° E, to Moscow, to 55° N 20° E. Thence south along the borders between Poland and the following countries: Russian Federation, Lithuania, Belarus and Ukraine. Thence along the border between Ukraine and the following countries: Poland, Slovakia, Hungary and Romania, to junction of the borders of Ukraine, Romania and Moldova. Thence along the borders of Romania and Moldova, Romania and Ukraine to the Black Sea coast at the meridian 30° E. Along the meridian 30° E to the Black Sea coast of Turkey. Along this coastline to the junction of the border between Turkey and Georgia. Thence along the borders between Turkey and the following countries: Georgia, Armenia and Azerbaijan, to the junction of the borders between the Islamic Republic of Iran and Azerbaijan. Then along the northern borders of the Islamic Republic of Iran to the Caspian Sea, then along the south coast of the Caspian Sea and thence north along the East Caspian Sea coast and through the point 47° N 53° E to 55° N 60° E.

### 27/110 *Regional and Domestic Air Route Area – 3 (RDARA-3)*

From the North Pole to the point 55° N 60° E, thence along the 55° N parallel to 88° E. Then along the 88° E meridian to the intersection of the Mongolia-China-Russian Federation borders at approximately 49° N 88° E. Then along the borders between Mongolia and China, and the Russian Federation and China, to the coast. Between the territorial waters of the Russian Federation and Japan to the point 43° N 147° E and through the point 50° N 164° E to 65° N 170° W. Then along the 170° W meridian to the North Pole.

### 27/111 *Sub-Area 3A*

From the North Pole along the 60° E meridian to 55° N. Then along the 55° N parallel to 88° E. Then through the point 60° N 88° E to 60° N 110° E, and along the 110° E meridian to the North Pole.

### 27/112 *Sub-Area 3B*

From the North Pole along the 110° E meridian to 60° N 110° E, and through the points 60° N 147° E, 43° N 147° E, 50° N 164° E, to 65° N 170° W. Then along the 170° W meridian to the North Pole.

### 27/113 *Sub-Area 3C*

From the point 60° N 88° E to the intersection of Mongolia-China-the Russian Federation borders at approximately 49° N 88° E. Along the borders between Mongolia and China, and the Russian Federation and China, to the coast. Between the territorial waters of the Russian Federation and Japan to the point 43° N 147° E. Then through the point 60° N 147° E to the point 60° N 88° E.

27/114 *Regional arid Domestic Air Route Area – 4 (RDARA-4)*

From the point 30° N 39° W, and through the points 10° N 20° W, 05° S 20° W, to the point 05° S 12° E. Thence along the border between the Rep. of the Congo and Angola, then along the northern border of the Dem. Rep. of the Congo, and the borders of the Rep. of the Congo, of the Central African Republic and South Sudan. Thence north along the western borders of South Sudan and the Sudan. Along the western border of Egypt, northwards to the Mediterranean and along the Mediterranean and Atlantic coasts of North Africa to the point 30° N 10° W. West along the 30° N parallel to close the area at 30° N 39° W. (WRC-19)

27/115 *Sub-Area 4A*

From the point 30° N 39° W to 21° N 31° W. Thence to Gao and to Zinder. From Zinder, along the northern border of Nigeria, to the junction of the borders of Nigeria, Chad and Cameroon. Then along the border between Chad and Cameroon to a point west of N'Djamena. Then along the parallel to 12° N 22° E. Thence north along the western border of the Sudan, and along the western border of Egypt to the Mediterranean. Along the North African Mediterranean coast and Atlantic coast to a point 30° N 10° W. Thence along the 30° N parallel to close the sub-area at 30° N 39° W.

27/116 *Sub-Area 4B*

From the point 21° N 31° W, through the points 10° N 20° W, 05° S 20° W to 05° S 12° E. Thence along the southern border of the Rep. of the Congo and the Central African Republic to the junction between the Dem. Rep. of the Congo, South Sudan and the Central African Republic. Along the western border of South Sudan and the Sudan to the point 12° N 22° E. Thence along the N'Djamena parallel to the Nigerian border. Then westward along this border to the point 13° 12' N 10° 45' E, through Zinder and Gao, to the point 21° N 31° W. (WRC-19)

27/117 *Regional and Domestic Air Route Area – 5 (RDARA-5)*

From the point 41° N 40° E to the point 37° N 40° E. Then along the border between Turkey and Syrian Arab Republic to the Mediterranean coast. Thence to the common border of Libya and Egypt on the North African coast excluding Cyprus. Southward along the western border of Egypt, the Sudan and South Sudan to the border of Kenya. Thence east along the northern border of Kenya, then south along the border between Kenya and Somalia and to the East African coast at 02° S 41° E. Then through the point 02° S 73° E to 37° N 73° E. Then east along the border between Afghanistan and Pakistan, and west along the northern borders of Afghanistan and the Islamic Republic of Iran to the Caspian Sea. Then along the northern border of the Islamic Republic of Iran and Turkey to close the area at 41° N 40° E. (WRC-19)

## AP27-32

### 27/118 *Sub-Area 5A*

From the point 37° N 40° E, along the border between Turkey and the Syrian Arab Republic to the Mediterranean coast. Thence to the Libyan -Egyptian border on the North African coast, excluding Cyprus. Southward, along the western border of Egypt and east along the common border of Egypt and the Sudan to 24° N 37° E. Then through the points 11° 45' N 42° E, 11° 45' N 55° E, 20° N 52° E, to the point 26° N 52° E. Thence along the border between Islamic Republic of Iran and Iraq, and the border between Iraq and Turkey, to the point 37° N 40° E.

### 27/119 *Sub-Area 5B*

From the point 41° N 40° E to 37° N 40° E. Thence east along the borders between Turkey and Syrian Arab Republic and Turkey and Iraq, and along the border between Iraq and the Islamic Republic of Iran to the point 30° N 49° E. Thence along the middle of the Gulf through the points 26° N 52° E and 24° N 60° E, to Mumbai. Then to 37° N 73° E. Then east along the border between Afghanistan and Pakistan, then west along the northern borders of Afghanistan and the Islamic Republic of Iran, to the Caspian Sea. Then along the northern border of the Islamic Republic of Iran and Turkey to close the sub-area at 41° N 40° E.

### 27/120 *Sub-Area 5C*

From the point 26° N 52° E, and through the points 13° N 52° E, 13° N 54° E, 02° S 54° E, 02° S 73° E, to Mumbai. Then to 24° N 60° E. Then along the middle of the Gulf to 26° N 52° E.

### 27/121 *Sub-Area 5D*

From the junction of Egypt, Libya and the Sudan southward along the western border of the Sudan and South Sudan to the border of Kenya. Thence along the northern border of Kenya. Then south along the border between Kenya and Somalia to the east African coast, at the point 02° S 42° E. Then through the points 02° S 54° E, 13° N 54° E, 13° N 52° E to the point 12° N 44° E. Thence northwest along the middle of the Red Sea to 24° N 37° E. Thence along the southern border of Egypt to close the sub-area. (WRC-19)

### 27/122 *Regional and Domestic Air Route Area – 6 (RDARA-6)*

From approximately 49° N 88° E, eastward along the border between China and the following countries: the Russian Federation, Kazakhstan, Kyrgyzstan, Tajikistan and Afghanistan. Then along the border between Afghanistan and Pakistan, and the Islamic Republic of Iran and Pakistan to the point 23° N 61° E. Thence to Mumbai. Then along the 73° E meridian to the point 02° S 73° E, and through the points 02° S 92° E, 10° S 92° E, 10° S 141° E, 00° 141° E, 00° 160° E, 03° 30' N 160° E, 03° 30' N 170° W, 10° N 170° W, 50° N 164° E, to the point 43° N 147° E. Thence west between the territorial waters of Japan and the Russian Federation and along the north-eastern and northern border of China to approximately 49° N 88° E.

27/123 *Sub-Area 6A*

From the point 37° N 75° E, along the border between Pakistan and Afghanistan, and the Islamic Republic of Iran and Pakistan to the point 23° N 61° E. Thence to Mumbai. From Mumbai to 24° N 80° E. Thence to Calcutta. Thence along the coast of Bangladesh and Myanmar to reach the border between Myanmar and Thailand. North along this border and that between Myanmar and Lao (P.D.R.). Thence along the border between China and Myanmar. Thence westward along the southern border of China to the point 37° N 75° E.

27/124 *Sub-Area 6B*

From the point 39° 49' 41" N 124° 10' 06" E, through the points 39° 31' 51" N 124° 06' 31" E, 39° N 124° E to the point 32° 30' N 124° E. Between the point 32° 30' N 124° E and the point 25° N 123° E, the limit of this Sub-Area is undefined. From the point 25° N 123° E, through the points 21° N 121° 30' E, 20° N 120° E, 20° N 176° W, 50° N 164° E, 43° N 147° E, thence west between the territorial waters of Japan and the Russian Federation and along the border between the Dem. People's Rep. of Korea and the Russian Federation, and then the border between China and the Dem. People's Rep. of Korea, to the point 39° 49' 41" N 124° 10' 06" E.

27/125 *Sub-Area 6C*

From the point 20° N 130° E through the point 04° N 130° E to 04° N 118° E. Thence along the southern borders of Sabah and Sarawak to the coast and then southward along the west coast of Borneo to the 110° E meridian. Thence along 110° E meridian to the point 10° S 110° E. Thence through the points 10° S 141° E, 00° 141° E, 00° 160° E, 03° 30' N 160° E, 03° 30' N 170° W, 10° N 170° W, 20° N 176° W to 20° N 130° E.

27/126 *Sub-Area 6D*

From the junction of the borders of China, India and Myanmar, south along the India-Myanmar and Bangladesh-Myanmar borders to the Bay of Bengal. Along the coast of Myanmar to its southernmost point, then to Weh Island (off the north coast of Sumatra). Then to the point 02° S 92° E, and through the point 10° S 92° E to 10° S 110° E. Then eastward to 10° S 141° E extending northward to 00° 141° E and then to 04° N 130° E through the point 20° N 130° E to 20° N 113° E. Thence, south around the Island of Hainan, and along the border between China, Viet Nam, the Lao (P.D.R.) and Myanmar, to close the Sub-Area at the junction of the borders of China, India and Myanmar.

27/127 *Sub-Area 6E*

From the point 20° N 73° E, and through the points 02° S 73° E, 02° S 92° E, through Weh Island (off the north coast of Sumatra) to 10° N 97° E. Thence along the coasts of Myanmar, Bangladesh and India to Calcutta. Then through the points 24° N 80° E to 20° N 73° E.

27/128 *Sub-Area 6F*

From the point 25° N 123° E, 21° N 121° 30' E, 20° N 120° E, 20° N 113° E, thence south around the Island of Hainan and along China-Viet Nam, China-Lao (P.D.R.) and China-Myanmar borders to the junction of the borders of China, India and Myanmar, south along the India-Myanmar and Bangladesh-Myanmar borders to the Bay of Bengal. Along the coast of Myanmar to its southernmost point then to Weh Island (off the north coast of Sumatra). Then to the point 02° S 92° E and through the point 10° S 92° E to 10° S 110° E. Then northward along 110° E meridian, thence along the boundary of Sub-Area 6C to the points 20° N 130° E, 43° N 147° E, thence westward between the territorial waters of Japan and the Russian Federation and along the border between the Dem. People's Rep. of Korea and the Russian Federation, then the border between China and the Dem. People's Rep. of Korea, to the points 39° 49' 41" N 124° 10' 06" E, 39° 31' 51" N 124° 06' 31" E, 39° N 124° E, then to the point 32° 30' N 124° E.

Between the points 32° 30' N 124° E and 25° N 123° E, the limit of this Sub-Area is undefined.

27/129 *Sub-Area 6G*

From the point 32° 30' N 124° E northward to 39° N 124° E, 39° 31' 51" N 124° 06' 31" E then to 39° 49' 41" N 124° 10' 06" E on the border between China and the Dem. People's Rep. of Korea. Then along the border of China to the junction of the border with India and Myanmar. Thence southward along the India-Myanmar and Bangladesh-Myanmar borders to the Bay of Bengal. Along the coast of Myanmar to its southernmost point. Then to Weh Island (off the north coast of Sumatra). Then to the point 02° S 92° E and through the point 10° S 92° E to 10° S 110° E. Then eastward to 10° S 141° E extending northward to 00° 141° E and then to 04° N 130° E through the point 20° N 130° E to 20° N 120° 40' E. Thence northward to the points 21° N 121° 30' E and 25° N 123° E.

Between the points 25° N 123° E and the point 32° 30' N 124° E, the limit of this Sub-Area is undefined.

In the area where Sub-Areas 6D, 6F and 6G are common, the frequencies allotted to Sub-Area 6G shall be used only by the aeronautical stations of China; the frequencies allotted to Sub-Areas 6D and 6F will be used only by the aeronautical stations of the other administrations in the common area. Also in this common area, the operational use by China of the frequencies allotted to Sub-Area 6G shall be within the area defined by a line starting at 21° 32' 52" N 108° E, passing through the points 20° N 108° E, 20° N 107° E, 18° N 107° E, 18° N 108° E, 15° N 110° E, 10° N 110° E, 06° N 108° E, 03° 30' N 112° E, 04° N 113° E, 08° N 116° E, 10° N 118° E, 14° N 119° E, 18° N 119° E to 20° N 120° 40' E and thence along the limit of Sub-Area 6D to 21° 32' 52" N 108° E.

27/130 *Regional and Domestic Air Route Area – 7 (RDARA-7)*

From the South Pole along the 20° W meridian to 05° S. Then along the 05° S parallel to 12° E. Thence along the border between the Rep. of the Congo and Angola, then along the northern border of the Dem. Rep. of the Congo, along the border between Uganda and South Sudan, and the borders between Kenya and South Sudan, Ethiopia and Somalia, to the point 02° S 42° E. Then to 02° S 60° E and along the 60° E meridian to 11° S, then through the points 11° S 65° E, 40° S 65° E, 40° S 60° E to the South Pole. (WRC-19)

27/131 *Sub-Area 7A*

From the South Pole along the 20° W meridian to 05° S. Then through the points 05° S 10° E, 40° S 10° E, to 40° S 60° E. Then along the 60° E meridian to the South Pole.

27/132 *Sub-Area 7B*

From the point 05° S 10° E to 05° S 12° E. Thence along the border between the Rep. of the Congo and Angola, then along the northern border of the Dem. Rep. of the Congo, to the junction of the borders of Uganda, the Dem. Rep. of the Congo and South Sudan. Thence along the eastern borders of the Dem. Rep. of the Congo, Rwanda, Burundi, and the Dem. Rep. of the Congo. Thence along the southern borders of the Dem. Rep. of the Congo and Angola to the coast of the South Atlantic. Thence to the point 17° S 10° E, and then to the point 05° S 10° E. (WRC-19)

27/133 *Sub-Area 7C*

From the junction of the borders of Uganda, the Dem. Rep. of the Congo and South Sudan along the western borders of Uganda and Tanzania, and then along the southern border of Tanzania to the coast. Thence through the points 11° S 41° E, 11° S 60° E, 02° S 60° E, to 02° S 41° E and thence to the east coast of Africa. Then north along the eastern border of Kenya, then west along the northern borders of Kenya and Uganda to close the sub-area at the junction of the borders of the Dem. Rep. of the Congo, South Sudan and Uganda. (WRC-19)

27/134 *Sub-Area 7D*

From the border between Tanzania and Mozambique on Lake Nyasa, south along the west border of Mozambique to the east coast of Africa, then through the points 27° S 33° E, 40° S 33° E, 40° S 65° E, 11° S 65° E to 11° S 41° E. Thence along the northern border of Mozambique to Lake Nyasa.

27/135 *Sub-Area 7E*

From the point 17° S 10° E, and through the points 40° S 10° E, 40° S 33° E, to 27° S 33° E. Thence along the west border of Mozambique and the part of the western border of Tanzania as far as the northern point of Lake Nyasa. Thence along the borders between Malawi and Tanzania and between Zambia and Tanzania and along the borders between the Dem. Rep. of the Congo and Zambia, Angola and Zambia, and Angola and Namibia to the coast at the point 17° S 10° E.

27/136 *Sub-Area 7F*

From the point 05° S 10° E to 05° S 12° E, along the border between the Rep. of the Congo and Angola to the junction point of the borders of the Rep. of the Congo, Angola, and the Dem. Rep. of the Congo. Thence along the border between Angola and the Dem. Rep. of the Congo until the coast of the Atlantic, along the coastline until the Zaire River and thence along the northern, eastern and southern border of Angola to the coast of the South Atlantic. Thence to the point 17° S 10° E and then to the point 05° S 10° E.

**AP27-36**

**27/137**     *Regional and Domestic Air Route Area – 8 (RDARA-8)*

From the South Pole along the 60° E meridian to 40° S then through the points 40° S 65° E, 11° S 65° E, 11° S 60° E, 02° S 60° E, 02° S 92° E, 10° S 92° E, to 10° S 110° E. Then along the 110° E meridian to the South Pole.

**27/138**     *Regional and Domestic Air Route Area – 9 (RDARA-9)*

From the South Pole along the 160° E meridian to 27° S. Then through the points 19° S 153° E, 10° S 145° E, 10° S 141° E, 00° 141° E, 00° 160° E, 03° 30' N 160° E, 03° 30' N 120° W. Then along the 120° W meridian to the South Pole.

**27/139**     *Sub-Area 9B*

From the point 00° 141° E through points 10° S 141° E, 10° S 145° E, 27° S 160° E, 27° S 157° W, 03° 30' N 157° W, 03° 30' N 160° E, 00° 160° E to the point 00° 141° E.

**27/140**     *Sub-Area 9C*

From the South Pole along the 170° W meridian to 03° 30' N. Then through the point 03° 30' N 120° W and along the 120° W meridian to the South Pole.

**27/141**     *Sub-Area 9D*

From the South Pole along the 160° E meridian to 27° S. Then through the point 27° S 170° W and along the 170° W meridian to the South Pole.

**27/142**     *Regional and Domestic Air Route Area – 10 (RDARA-10)*

From the point 50° N 164° E to 66° N 169° W. Then along the 169° W meridian to the North Pole. Then through the points 82° N 30° E, 82° N 00°, 73° N 00°, 73° N 15° W. Then along the 15° W meridian to 72° N. Then through the points 40° N 50° W, 40° N 65° W to 44° 30' N 73° W, 41° N 81° W, 41° N 88° W, 48° N 91° W, 48° N 127° W, 50° N 130° W, then westward to the point 50° N 164° E.

**27/143**     *Sub-Area 10A*

From the point 50° N 164° E to 66° N 169° W, along the 169° W meridian to the North Pole, along the 130° W meridian to 50° N, then westward to the point 50° N 164° E.

**27/144**     *Sub-Area 10B*

From the point 57° N 140° W, along the 140° W meridian to the North Pole. Then along the 91° W meridian to 48° N. Thence through the points 48° N 127° W, 57° N 139° W, to 57° N 140° W.

27/145 *Sub-Area 10C*

From the point 57° N 140° W, and through the points 60° N 140° W, 60° N 91° W, 48° N 91° W, 48° N 127° W, 57° N 139° W, to 57° N 140° W.

27/146 *Sub-Area 10D*

From the point 48° N 98° W, along the 98° W meridian to the North Pole. Then along the 45° W meridian to 69° N. Then through the points 61° N 70° W, 45° N 72° W, 41° N 81° W, 41° N 88° W, 48° N 91° W, to 48° N 98° W.

27/147 *Sub-Area 10E*

From the point 45° N 74° W, and through the point 61° N 72° W to 69° N 47° W. Then along the 47° W meridian to the North Pole. Then along the 15° W meridian to 72° N. Then through the points 40° N 50° W, 40° N 65° W, to close the sub-area at 45° N 74° W.

27/148 *Sub-Area 10F*

From the North Pole through the points 82° N 30° E, 82° N 00°, 73° N 00°, 73° N 20° W, 70° N 20° W, 63° 30' N 39° W, 58° 30' N 43° W, 58° 30' N 50° W, 63° 30' N 55° 44' W, 65° 30' N 58° 39' W, 74° N 68° 18' W, 76° N 76° W, 78° N 75° W, 82° N 60° W to the North Pole.

27/149 *Regional and Domestic Air Route Area – 11 (RDARA-11)*

From the point 29° N 180° through the points 50° N 164° E, 50° N 127° W. Then along the border between the United States of America and Canada to 46° N 67° W, then to 40° N 65° W, 40° N 50° W, 25° N 35° W, 25° N 98° W, 33° N 119° W, 33° N 153° W, 29° N 153° W to the point 29° N 180°.

27/150 *Sub-Area 11A*

From the point 29° N 180°, through the points 50° N 164° E, 50° N 130° W, 33° N 130° W, 33° N 153° W, 29° N 153° W, to the point 29° N 180°.

27/151 *Sub-Area 11B*

From the point 50° N 130° W and through the points 33° N 130° W, 33° N 119° W, 25° N 98° W, 25° N 65° W, 40° N 65° W, 46° N 67° W. Then along the border between the United States of America and Canada through 50° N 127° W, to the point 50° N 130° W.

27/152 *Sub-Area 11C*

From the point 25° N 65° W and through the points 40° N 65° W, 40° N 50° W, 25° N 35° W, to the point 25° N 65° W.



**AP27-38****27/153**     *Regional and Domestic Air Route Area – 12 (RDARA-12)*

From the point 03° 30' N 170° W to the point 10° N 170° W, then along the boundary between ITU Regions 2 and 3 to 29° N 180°, and thence to 29° N 153° W, 33° N 153° W, through the points 33° N 120° W, 35° N 120° W, 32° N 104° W, 25° N 91° W, 26° N 91° W, 26° N 79° W, 27° N 79° W, 27° N 76° 30' W, 25° N 70° W, 25° N 35° W and along the boundary between ITU Regions 1 and 2 to 00° 20' W. Thence through the points 00° 44' W, 04° 24' N 50° 39' W. Then along the boundaries between Brazil and the French Guiana, Surinam, Guyana, Venezuela, Colombia to the junction of Brazil, Peru and Colombia then along the boundaries between Peru and Colombia and Peru and Ecuador to the point 04° S 93° W. Then to the point 05° S 93° W and through the points 05° S 120° W, 03° 30' N 120° W to the point 03° 30' N 170° W.

**27/154**     *Sub-Area 12A*

From the point 03° 30' N 170° W to the point 10° N 170° W, then along the boundary between ITU Regions 2 and 3 to 29° N 180°, and thence through the points 29° N 153° W, 03° 30' N 153° W to the point 03° 30' N 170° W.

**27/155**     *Sub-Area 12B*

From the point 03° 30' N 153° W to 33° N 153° W, through the points 33° N 120° W, 17° N 115° W, 14° N 93° W, 02° N 86° W, 02° N 93° W, 05° S 93° W, 05° S 120° W, 03° 30' N 120° W, to the point 03° 30' N 153° W.

**27/156**     *Sub-Area 12C*

From the point 33° N 120° W, through the points 35° N 120° W, 32° N 104° W, 25° N 91° W, 23° N 83° W, 22° N 83° W, 13° N 90° W, 16° N 116° W, to the point 33° N 120° W.

**27/157**     *Sub-Area 12D*

From the point 20° N 91° W, through the points 26° N 91° W, 26° N 79° W, 27° N 79° W, 27° N 76° 30' W, 26° N 73° W, 17° N 58° W, to 10° N 58° W. Thence through Panama City, Colon, Swan Island, and Belize City to the point 20° N 91° W.

**27/158**     *Sub-Area 12E*

From the point 15° N 95° W and through 23° N 92° W, 23° N 85° W, 19° N 85° W, 09° N 77° W, 02° N 79° W. Thence to 01° N 75° W along the eastern and southern border of Ecuador to the point 04° S 81° W, and from there to 02° N 81° W and 02° N 86° W, 14° N 93° W to close the sub-area at 15° N 95° W.

**27/159**     *Sub-Area 12F*

From the point 02° N 79° W to the point 08° N 83° W, then along the border between Panama and Costa Rica, through the points 10° N 83° W, 13° N 83° W, 13° N 70° W, 08° N 70° W, 06° N 67° W and 01° N 66° W. Then along the border between Brazil and Colombia to 04° S 70° W. Thence along the border between Colombia and Peru, continuing along the border between Colombia and Ecuador, to the point 02° N 79° W.

27/160 *Sub-Area 12G*

From the point 07° N 73° W, through the points 14° N 73° W, 14° N 58° W, 01° 31' N 58° W and along the borders of Brazil with Guyana, Venezuela, Colombia through the points 01° 57' N 68° W, 05° N 69° W, to the point 07° N 73° W.

27/161 *Sub-Area 12H*

From the point 05° N 70° W, through the points 08° 45' N 60° W, 08° N 58° W, 08° N 49° W, 04° 10' N 51° 36' W, and along the borders of Brazil with French Guiana, Surinam, Guyana, Venezuela and Colombia to the junction of the borders of Brazil, Colombia and Peru, to the point 05° N 70° W.

27/162 *Sub-Area 12I*

From the point 25° N 70° W, through the point 25° N 35° W and along the boundary between ITU Regions 1 and 2, to 00° 20' W. Thence through the points 00° 44' W, 08° N 54° W, 08° N 58° W, 17° N 58° W, to the point 25° N 70° W.

27/163 *Sub-Area 12J*

From the point 04° S 93° W, through the points 02° N 93° W, 02° N 79° W. Then along the border between Ecuador and Colombia to the junction with the borders of Colombia, Peru and Ecuador. Thence along the border between Peru and Ecuador to the point 04° S 93° W.

27/164 *Regional and Domestic Air Route Area – 13 (RDARA-13)*

From the South Pole along the 120° W meridian to 05° S. Then through the points 05° S 93° W, 04° S 82° W, and along the southern border of Ecuador, Colombia, Venezuela, Guyana, Surinam, the French Guiana, to the point 04° 24' N 50° 39' W. Then through the points 04° 24' N 47° W, 00° 32' W to the point 00° 20' W, and along the 20° W meridian to the South Pole.

27/165 *Sub-Area 13A*

From the point 05° S 120° W through the points 05° S 93° W, 04° S 82° W, 19° S 81° W, 57° S 81° W, to 57° S 90° W. Thence to the South Pole to the point 05° S 120° W.

27/166 *Sub-Area 13B*

From the point 29° S 111° W, through the points 24° S 111° W, 24° S 104° W, 29° S 104° W, to the point 29° S 111° W.

**AP27-40**

27/167 *Sub-Area 13C*

From the point 15° S 47° W, through the points 20° S 44° W, 23° 19' S 42° W, 25° S 45° W, 22° 30' S 50° 39' W, 19° 52' S 58° W, and along the borders of Brazil with Paraguay, Bolivia, Peru, Colombia, Venezuela, Guyana, Surinam and French Guiana to 04° 24' N 50° 39' W, 04° 24' N 47° W, to the point 15° S 47° W.

27/168 *Sub-Area 13D*

From 11° S 69° 30' W along the border between Bolivia and Brazil and through the point 20° 10' S 58° W, along the border between Bolivia and Paraguay to 22° 30' S 62° 30' W. Then along the border between Bolivia and Argentina and through the point 23° S 67° W along the border between Bolivia and Chile and through the point 16° 30' S 69° 30' W following the border between Bolivia and Peru to the point 11° S 69° 30' W.

27/169 *Sub-Area 13M*

From the point 19° S 81° W, through the points 04° S 82° W, 03° S 80° W, following the boundaries between Peru and Ecuador, Colombia and Brazil to the point 11° S 69° 30' W, along the border of Peru with Bolivia to 17° 30' S 69° 30' W, then along the border of Peru with Chile to the point 19° S 81° W.

27/170 *Sub-Area 13N*

From the point 22° 30' S 62° 30' W along the border of Paraguay with Bolivia to 20° 10' S 58° W, along the border of Paraguay with Brazil to 25° 50' S 54° 30' W and thence along the border of Paraguay with Argentina to the point 22° 30' S 62° 30' W.

27/171 *Sub-Area 13E*

From the point 32° S 81° W through the point 19° S 81° W, up to the intersection of the coast with the border between Chile and Peru, Bolivia and Argentina, to the point of intersection with 32° S and then to the point 32° S 81° W.

27/172 *Sub-Area 13F*

From the point 57° S 81° W, through the point 32° S 81° W to the intersection of 32° S with the border between Chile and Argentina, through the points 52° S 67° W, 57° S 67° W, 57° S 40° W to the South Pole to the point 57° S 81° W.

27/173 *Sub-Area 13G*

From the point 36° S 55° W to the intersection of 32° S with the border between Argentina and Chile, then north along the borders of Argentina with Bolivia, Paraguay, Brazil and Uruguay to the point 36° S 55° W.

27/174 *Sub-Area 13H*

From the point 57° S 90° W and through the point 57° S 70° W to 52° S 70° W. Then along the border between Chile and Argentina to its intersection by 32° S and through the points 36° S 55° W, 57° S 55° W, 57° S 25° W to the South Pole and then to the point 57° S 90° W.

27/175 *Sub-Area 13I*

From the point 40° S 50° W through the point 36° S 55° W and along the borders of Uruguay with Argentina and Brazil, then through the point 35° S 45° W to the point 40° S 50° W.

27/176 *Sub-Area 13J*

From the point 15° S 47° W through the points 20° S 44° W, 23° 19' S 42° W, 29° S 40° W, 35° S 45° W, and thence along the borders of Brazil with Uruguay, Argentina, Paraguay and Bolivia to the point 19° 52' S 58° W, then through the point 18° S 57° 37' W to the point 15° S 47° W.

27/177 *Sub-Area 13K*

From the point 22° 30' S 50° 39' W and through the points 25° S 45° W, 29° S 40° W, 20° S 32° W, 00° 32' W, 04° 24' N 47° W, 04° 24' N 50° 39' W to the point 22° 30' S 50° 39' W.

27/178 *Sub-Area 13L*

From the point 00° 32° W through the points 00° 20° W, the South Pole, 57° S 55° W, 36° S 55° W, 40° S 50° W, 20° S 32° W, to the point 00° 32° W.

27/179 *Regional and Domestic Air Route Area – 14 (RDARA-14)*

From the South Pole along the 110° E meridian to 10° S. Then through the points 10° S 145° E, 19° S 153° E, 27° S 160° E. Then along the 160° E meridian to the South Pole.

27/180 *Sub-Area 14A*

From the South Pole along the 110° E meridian to 19° S. Then through the points 19° S 118° E, 24° S 120° E, 24° S 131° E. Then along the 131° E meridian to the South Pole.

27/181 *Sub-Area 14B*

From the point 19° S 110° E to the point 10° S 110° E, thence through 10° S 131° E, 24° S 131° E, 24° S 120° E, 19° S 118° E to the point 19° S 110° E.

27/182 *Sub-Area 14C*

From the point 24° S 131° E to the point 10° S 131° E, thence through 10° S 139° E, 24° S 139° E to the point 24° S 131° E

**AP27-42**

27/183 *Sub-Area 14D*

From the South Pole along the 131° E meridian to 24° S, then through the points 24° S 139° E, 27° S 139° E, 27° S 142° E, 34° S 142° E, 34° S 139° E. Then along the 139° E meridian to the South Pole.

27/184 *Sub-Area 14E*

From the point 24° S 139° E along the 139° E meridian to 10° S, then through the points 10° S 145° E, 19° S 153° E to the point 24° S 139° E.

27/185 *Sub-Area 14F*

From the point 27° S 139° E along the 139° E meridian to 24° S, then through the points 19° S 153° E, 27° S 160° E to the point 27° S 139° E.

27/186 *Sub-Area 14G*

From the South Pole along the 139° E meridian to 34° S, then through the points 34° S 142° E, 27° S 142° E, 27° S 160° E. Then along the 160° E meridian to the South Pole.

ARTICLE 3

**Description of the boundaries of the VOLMET allotment areas  
and VOLMET reception areas**

*VOLMET Area - AFRICA-INDIAN OCEAN (AFI-MET)*

27/187 *The AFI-MET allotment area is defined by a line drawn from the point 29° N 20° W, through the points 37° N 03° W, 37° N 36° E, 30° N 35° E, 10° N 52° E, 22° S 60° E, 35° S 35° E, 35° S 15° E, 08° S 15° W, 12° N 20° W, to the point 29° N 20° W.*

27/188 *The AFI-MET reception area is defined by a line drawn from the point 37° N 03° W, through the points 37° N 36° E, 30° N 35° E, 10° N 52° E, 10° N 100° E, the South Pole, the points 29° N 40° W, 29° N 20° W, to the point 37° N 03° W.*

*VOLMET Area - NORTH ATLANTIC (NAT-MET)*

27/189 *The NAT-MET allotment area is defined by a line drawn from the point 41° N 78° W, through the points 51° N 55° W, 24° N 50° W, 24° N 74° W, to the point 41° N 78° W.*

27/190 *The NAT-MET reception area is defined by a line drawn from the point 24° N 97° W, through the points 24° N 85° W, 75° N 85° W, 75° N 20° W, 00° 20° W, 00° 95° W, to the point 24° N 97° W.*

*VOLMET Area - EUROPE (EUR-MET)*

27/191 The *EUR-MET allotment area* is defined by a line drawn from the point 33° N 12° W, through the points 54° N 12° W, 70° N 00°, 74° N 40° E, 40° N 36° E, 29° N 35° 30' E, 32° N 13° E, to the point 33° N 12° W.

27/192 The *EUR-MET reception area* is defined by a line drawn from the point 15° N 20° W, through the points 40° N 50° W, 75° N 50° W, 75° N 45° E, 15° N 45° E, to the point 15° N 20° W.

*VOLMET Area - MIDDLE EAST (MID-MET)*

27/193 The *MID-MET allotment area* is defined by a line drawn from the point 50° N 80° E, through the points 29° N 80° E, 27° N 85° E, 16° N 78° E, 22° N 56° E, 16° N 42° E, 30° N 30° E, 51° N 30° E, 57° N 37° E, to the point 50° N 80° E.

27/194 The *MID-MET reception area* is defined by a line drawn from the point 50° N 80° E, through the points 50° N 90° E, 35° N 90° E, 27° N 85° E, 16° N 78° E, 22° N 56° E, 16° N 42° E, 30° N 30° E, 51° N 30° E, 57° N 37° E, to the point 50° N 80° E.

*VOLMET Area - NORTH CENTRAL ASIA (NCA-MET)*

27/195 The *NCA-MET allotment area* is defined by a line drawn from the point 76° N 32° E, through the points 80° N 90° E, 75° N 168° W, 66° N 168° W, 48° N 160° E, 42° N 135° E, 50° N 130° E, 50° N 90° E, 35° N 70° E, 45° N 30° E, 60° N 20° E, to the point 76° N 32° E.

27/196 The *NCA-MET reception area* is defined by a line drawn from the North Pole, through the points 40° N 168° W, 30° N 140° E, 35° N 70° E, 30° N 20° E, to the North Pole.

*VOLMET Area - PACIFIC (PAC-MET)*

27/197 The *PAC-MET allotment area* is defined by a line drawn from the point 52° N 132° E, through the points 63° N 149° W, 38° N 120° W, 50° S 120° W, 50° S 145° E, 28° S 145° E, 03° S 129° E, 22° N 112° E to the point 52° N 132° E.

27/198 The *PAC-MET reception area* is defined by a line drawn from the point 60° N 100° E through the points 75° N 160° W, 75° N 110° W, 65° S 110° W, 65° S 145° E, 28° S 145° E, 03° S 129° E, 05° N 80° E, 40° N 80° E, to the point 60° N 100° E.

*VOLMET Area - SOUTH EAST ASIA (SEA-MET)*

27/199 The *SEA-MET allotment area* is defined by a line drawn from the point 55° N 75° E, through the points 55° N 135° E, 45° N 135° E, 35° N 130° E, 10° N 130° E, 10° S 155° E, 35° S 155° E, 35° S 116° E, 08° N 75° E, 26° N 65° E, to the point 55° N 75° E.

## AP27-44

27/200 The *SEA-MET reception area* is defined by a line drawn from the point 55° N 50° E, through the points 55° N 180°, 50° S 180°, 50° S 70° E, 08° N 70° E, 08° N 50° E, to the point 55° N 50° E.

### *VOLMET Area - CARIBBEAN (CAR-MET)*

27/201 The *CAR-MET allotment area* is defined by a line drawn from the point 30° N 110° W, through the points 30° N 75° W, 00° 50° W, following the equator to 00° 80° W to the point 30° N 110° W.

27/202 The *CAR-MET reception area* is defined by a line drawn from the point 40° N 120° W, through the points 40° N 20° W, 25° S 20° W, 25° S 120° W, to the point 40° N 120° W.

### *VOLMET Area - SOUTH AMERICA (SAM-MET)*

27/203 The *SAM-MET allotment area* is defined by a line drawn from the point 15° N 83° W, through the points 15° N 60° W, 05° S 35° W, 55° S 60° W, 55° S 83° W, to the point 15° N 83° W.

27/204 The *SAM-MET reception area* is defined by a line drawn from the point 30° N 120° W through the point 30° N 00°, the South Pole, to the point 30° N 120° W.

## ARTICLE 4

### **World-wide allotment areas**

#### 27/205 *World-wide Area I*

The boundaries of this allotment area comprise those of RDARAs 1, 2 and 3.

#### 27/206 *World-wide Area II*

The boundaries of this allotment area comprise those of RDARAs 10, 11 12A, 12B, 12C, and 12D.

#### 27/207 *World-wide Area III*

The boundaries of this allotment area comprise those of RDARAs 6, 8, 9 and 14.

27/208 *World-wide Area IV*

The boundaries of this allotment area comprise those of RDARAs 12E to 12J inclusive and 13.

27/209 *World-wide Area V*

The boundaries of this allotment area comprise those of RDARAs 4, 5 and 7.

## Section II – Allotment of frequencies in the aeronautical mobile (R) service

### ARTICLE 1

#### 27/210 Frequency allotment Plan by areas

27/211 NOTE a) \* = For the exact nature of a restriction on the use of the frequency concerned, refer to column 3 of the frequency allotment Plan in numerical order of frequencies (Nos. 27/218 to 27/231).

27/212 NOTE b) The following list does not include the world-wide common (R) and (OR) frequencies of 3 023 kHz and 5 680 kHz. The allotment of these frequencies is shown in Article 2.

## 27/213 (WRC-2000)

Area	Frequency bands (MHz)										
	3	3.5	4.7	5.4 (Reg. 2)	5.6	6.6	9	10	11.3	13.3	18
	kHz	kHz	kHz	kHz	kHz	kHz	kHz	kHz	kHz	kHz	kHz
AFI	2 851 2 878	3 419 3 425 3 467	4 657		5 493 5 652 5 658	6 559 6 574 6 673	8 894 8 903		11 300 11 330	13 273 13 288 13 294	17 961
CAR	2 887	3 455			5 520 5 550	6 577 6 586	8 846 8 918		11 387 11 396	13 297	17 907
CEP	2 869	3 413	4 657		5 547 5 574	6 673	8 843	10 057	11 282	13 300	17 904
CWP	2 998	3 455	4 666		5 652 5 661	6 532 6 562	8 903	10 081	11 384	13 300	17 904
EA	3 016	3 485 3 491			5 655 5 670	6 571	8 897	10 042	11 396	13 297 13 303 13 309	17 907
EUR		3 479			5 661	6 598		10 084		13 288	17 961
INO		3 476			5 634		8 879			13 306	17 961

(See cont.)



(Cont.)

Area	Frequency bands (MHz)										
	3	3.5	4.7	5.4 (Reg. 2)	5.6	6.6	9	10	11.3	13.3	18
	kHz	kHz	kHz	kHz	kHz	kHz	kHz	kHz	kHz	kHz	kHz
MID	2 944 2 992	3 467 3 473	4 669		5 658 5 667	6 625 6 631	8 918 8 951	10 018	11 375	13 288 13 312	17 961
NAT	2 872 2 889 2 962 2 971 3 016	3 476	4 675		5 598 5 616 5 649	6 622 6 628	8 825 8 831 8 864 8 879 8 891 8 906		11 279 11 309 11 336	13 291 13 306	17 946
NCA	3 004 3 019		4 678		5 646 5 664	6 592		10 096		13 303 13 315	17 958
NP	2 932				5 628	6 655 6 661		10 048	11 330	13 300	17 904
SAM	2 944	3 479	4 669		5 526	6 649	8 855	10 024 10 096	11 360	13 297	17 907
SAT	2 854 2 935	3 452			5 565	6 535	8 861		11 291	13 315 13 357	17 955
SEA		3 470 3 485			5 649 5 655	6 556	8 942	10 066	11 396	13 309 13 318	17 907
SP		3 467			5 559 5 643		8 867	10 084	11 327	13 300	17 904
1						6 556		10 021	11 363		
1B	2 860* 2 881* 2 890	3 458* 3 473* 3 488*			5 484 5 568	6 550 6 595		10 066			
1C	2 977 2 983	3 464 3 470	4 666		5 577 5 595	6 544	8 840		11 366		
1D	2 974 2 980 2 989	3 410 3 416 3 446	4 651		5 622 5 628 5 637	6 604 6 610	8 828	10 060	11 384		
1E	2 965	3 491			5 583	6 667		10 036			
2	2 938 2 950		4 696		5 556	6 583 6 601	8 846 8 855 8 888	10 015 10 045	11 297 11 360 11 390	13 321 13 357	17 964
2A	2 851* 2 863 2 869 2 875 2 881 2 887* 2 896 2 917 2 926 2 932 2 941	3 416* 3 422 3 434 3 440 3 455	4 657* 4 672 4 690		5 481 5 490 5 496 5 502 5 523 5 547 5 559 5 604	6 526 6 532 6 547 6 553 6 559 6 565 6 574 6 673	8 822* 8 876 8 909 8 939	10 048 10 054	11 276 11 285 11 294		

\* See No. 27/211.

(See cont.)

(Cont.)

Area	Frequency bands (MHz)										
	3	3.5	4.7	5.4 (Reg. 2)	5.6	6.6	9	10	11.3	13.3	18
	kHz	kHz	kHz	kHz	kHz	kHz	kHz	kHz	kHz	kHz	kHz
2B	2 857 2 869 2 875 2 881 2 887* 2 896 2 902 2 908 2 914 2 920 2 929	3 401 3 407 3 416* 3 422 3 428 3 449	4 660 4 672 4 681 4 690 4 693		5 490 5 496 5 502 5 508 5 520 5 526 5 550 5 574 5 595 5 607 5 613 5 619	6 526 6 532 6 562 6 568 6 577 6 655 6 661 6 667	8 819 8 834 8 864	10 009 10 024	11 279 11 333 11 339		
2C	2 857 2 863 2 866 2 884 2 893 2 902 2 908 2 914 2 920 2 926 2 932	3 401 3 407 3 428 3 434 3 440 3 449 3 455	4 657* 4 660 4 681 4 693		5 481 5 487 5 508 5 514 5 520 5 526 5 550 5 562 5 574 5 586 5 604	6 535 6 541 6 547 6 553 6 562 6 568 6 577 6 586	8 819 8 834 8 882 8 939	10 009 10 024 10 054	11 276 11 333 11 372		
3	2 893 2 935		4 693		5 556	6 583 6 589	8 846 8 954	10 087	11 318 11 336 11 360	13 267 13 321	17 952
3A	2 854 2 860 2 869 2 875 2 881 2 887* 2 896 2 905 2 911* 2 923* 2 959	3 404 3 416* 3 422 3 431* 3 443 3 452	4 672 4 684 4 690		5 484 5 490 5 496 5 502 5 511 5 517 5 568 5 580 5 601 5 625	6 526 6 532 6 538 6 544 6 550 6 556 6 607 6 613 6 619 6 649	8 837 8 861 8 900 8 942	10 045 10 057	11 309 11 324 11 330		
3B	2 851 2 854 2 872 2 878 2 884* 2 902 2 908 2 914 2 968*	3 401 3 407 3 413 3 419 3 425 3 431* 3 437* 3 443	4 657 4 681		5 493 5 499 5 505 5 514 5 520 5 526 5 550 5 562 5 580 5 601	6 529 6 538 6 544 6 559 6 568 6 577 6 595 6 625 6 631	8 822 8 852 8 861 8 879 8 957	10 024 10 039	11 285 11 291 11 327 11 372		

(See cont.)

(Cont.)

Area	Frequency bands (MHz)										
	3	3.5	4.7	5.4 (Reg. 2)	5.6	6.6	9	10	11.3	13.3	18
	kHz	kHz	kHz	kHz	kHz	kHz	kHz	kHz	kHz	kHz	kHz
3C	2 851 2 860 2 866* 2 878 2 905 2 950 2 974 2 980 2 986	3 404 3 410 3 419 3 425 3 452	4 684		5 484 5 514 5 562 5 568 5 586 5 637 5 643	6 550 6 556 6 595 6 658 6 664 6 670	8 837 8 852 8 894 8 915	10 039	11 291 11 303 11 324 11 378		
4						6 565	8 873			13 300	17 904
4A	2 926* 2 953	3 437 3 491	4 672*		5 547 5 559	6 526 6 532 6 616	8 816 8 837 8 858	10 039 10 081	11 282 11 318		
4B	2 866 2 893	3 443			5 481 5 574 5 604	6 553 6 577 6 598		10 063	11 324		
5							8 870 8 885	10 012	11 312 11 327	13 354	17 949 17 967
5A	2 986	3 452			5 577 5 583	6 544 6 664	8 822 8 915		11 288		
5B	2 911 2 968	3 431 3 488			5 511 5 568 5 625	6 550 6 595	8 912	10 093			
5C	2 905	3 452			5 583	6 544	8 822				
5D	2 899 2 971	3 482			5 526 5 550	6 535 6 547	8 843	10 048			
6							8 840		11 381	13 291	17 943
6A	2 872 2 923 2 947 3 001	3 479	4 657* 4 675		5 484 5 580 5 601	6 607 6 613 6 658	8 891 8 906 8 948	10 006 10 051 10 081*	11 321 11 357		
6B	2 857 2 920	3 479 3 488			5 502 5 595 5 625	6 607 6 613 6 619	8 864 8 885	10 021 10 093	11 339 11 366		17 955
6C	2 881 2 956	3 473	4 651		5 550 5 580	6 544 6 631	8 834 8 918	10 015			
6D	2 866 2 884	3 416			5 490 5 520 5 568 5 574 5 631	6 550 6 568 6 577 6 595	8 882 8 957		11 309 11 372		

(See cont.)

(Cont.)

Area	Frequency bands (MHz)										
	3	3.5	4.7	5.4 (Reg. 2)	5.6	6.6	9	10	11.3	13.3	18
	kHz	kHz	kHz	kHz	kHz	kHz	kHz	kHz	kHz	kHz	kHz
6E	2 854 2 872 2 917 3 001	3 443	4 657* 4 675		5 514 5 526 5 550	6 583 6 655 6 661	8 861* 8 906 8 909	10 036 10 051 10 084	11 357 11 363		
6F	2 926 2 941	3 434 3 440			5 496 5 508	6 526 6 667	8 864 8 939	10 060	11 279 11 366		
6G	2 869* 2 875* 2 890 2 896* 2 899 2 902* 2 911* 2 917* 2 938 2 953 2 962 2 968* 2 971 2 977 2 983 2 989 2 995	3 413* 3 422* 3 431* 3 437 3 446 3 449* 3 464 3 482	4 651* 4 663* 4 669* 4 672* 4 690* 4 696*		5 481 5 487 5 493* 5 499* 5 505* 5 511* 5 517* 5 523 5 547 5 553 5 559 5 565 5 571 5 577 5 583 5 592 5 598 5 604 5 610 5 616 5 622 5 622* 5 634* 5 640*	6 529 6 535 6 541 6 547 6 553 6 559 6 565 6 574 6 580 6 586 6 598 6 604 6 610 6 616 6 622 6 628 6 634 6 649 6 652 6 673 6 682	8 816 8 825 8 831 8 843 8 858 8 867 8 870* 8 873 8 888* 8 912* 8 960	10 018* 10 054* 10 063*	11 276* 11 282* 11 288 11 294* 11 300* 11 306 11 315 11 369	13 270 13 276	17 913
7					5 508	6 586	8 888		11 285	13 354	
7B	2 863 2 965	3 455			5 577 5 583	6 652	8 906	10 009			
7C	2 950	3 407			5 592	6 568 6 604	8 834	10 081	11 294		
7D	2 998				5 481			10 096			
7E	2 887	3 485			5 520	6 580 6 628	8 864		11 306		
7F	2 956	3 461			5 547 5 568	6 622	8 846 8 960				
9			4 696		5 583	6 553	8 846 8 852	10 018	11 339		

(See cont.)

(Cont.)

Area	Frequency bands (MHz)										
	3	3.5	4.7	5.4 (Reg. 2)	5.6	6.6	9	10	11.3	13.3	18
	kHz	kHz	kHz	kHz	kHz	kHz	kHz	kHz	kHz	kHz	kHz
9B	2 860 2 905 2 929*	3 401* 3 419 3 425 3 476*	4 660		5 484 5 508 5 523 5 565	6 538 6 547 6 598 6 622	8 819 8 837 8 861 8 906	10 009 10 024 10 039	11 393		
9C	2 851	3 404 3 461	4 675		5 481	6 580	8 873	10 042	11 279 11 312		
9D	3 016	3 404			5 592	6 535	8 873		11 312		
10			4 696	5 454	5 604	6 553	8 819 8 834	10 006 10 012	11 333 11 390	13 285	17 910
10A	2 866 2 875 2 911 2 944 2 956 2 992	3 449 3 470		5 472 5 475	5 484 5 490 5 496 5 565 5 631	6 535 6 580 6 604	8 855 8 876	10 066	11 357 11 363 11 375		
10B	2 854 2 860	3 404 3 467 3 488	4 651 4 666 4 681 4 690 4 693	5 460 5 466	5 553 5 568 5 583	6 547 6 574 6 598	8 837 8 903 8 939				
10C	2 926 2 965	3 491	4 660 4 669	5 457	5 481 5 487 5 502 5 562 5 595	6 541 6 556 6 568	8 867				
10D	2 893 2 935	3 419 3 425 3 458	4 666 4 669 4 678	5 472 5 475	5 484 5 490 5 496 5 586 5 625	6 535 6 544 6 562	8 858 8 900				
10E	2 869 2 944 2 992	3 446 3 473	4 651 4 666 4 684	5 460	5 481 5 559 5 577	6 547 6 598	8 843 8 954		11 276		
10F	2 950		4 663	5 451	5 526	6 673	8 945	10 042			
11B	2 851 2 878 3 004 3 019	3 410 3 428 3 434 3 443	4 672	5 451 5 463 5 469	5 508 5 514 5 523 5 571	6 538 6 550 6 559 6 565	8 822 8 885 8 912	10 045 10 093	11 288 11 306	13 312	17 964
12		3 440			5 568			10 054			17 901
12A	2 950				5 604						

(See cont.)

(Cont.)

Area	Frequency bands (MHz)										
	3	3.5	4.7	5.4 (Reg. 2)	5.6	6.6	9	10	11.3	13.3	18
	kHz	kHz	kHz	kHz	kHz	kHz	kHz	kHz	kHz	kHz	kHz
12C	2 920 2 980	3 401 3 464	4 693	5 460	5 484 5 490 5 496 5 502 5 589 5 613	6 535 6 571 6 592 6 622 6 628	8 816 8 948 8 957	10 021 10 039	11 324		
12D		3 407			5 562	6 673	8 876	10 015			
12E	2 860 2 956 2 998	3 461 3 488	4 681	5 454 5 475	5 481 5 487 5 583 5 595 5 604	6 547 6 553 6 598	8 852 8 873	10 063 10 090	11 381 11 393		
12F	2 893 2 956 2 965 2 998	3 461 3 488		5 451 5 475	5 508 5 556 5 583 5 604	6 532 6 553	8 873 8 894	10 090	11 297		
12G	2 875 2 956 2 998	3 461 3 488			5 484 5 523 5 559 5 646	6 526 6 616					
12H	2 956 2 998	3 461 3 488		5 451	5 583						
12J	2 860 2 902 2 926 2 965	3 419			5 481 5 496 5 619	6 535 6 547	8 954		11 381 11 384		
13										13 318	17 913
13A								10 048			17 967
13B								10 048			17 967
13C	2 863 2 869 2 992	3 413 3 458 3 473			5 490 5 514 5 553 5 571 5 577	6 541 6 556 6 562 6 568 6 580	8 819 8 834 8 843 8 939	10 042	11 327 11 375	13 309	
13D	2 914 2 983	3 425 3 467	4 660	5 460	5 562	6 622 6 628 6 673	8 867 8 912 8 957	10 084	11 318		
13E	2 851	3 491	4 651 4 663		5 481 5 583 5 604	6 553 6 577	8 858		11 303		17 967
13F	2 851 2 956 2 998	3 446 3 476	4 651 4 663	5 454	5 481 5 583 5 604	6 547 6 553	8 831 8 858 8 864	10 081	11 321 11 330		17 967

(See cont.)

(Cont.)

Area	Frequency bands (MHz)										
	3	3.5	4.7	5.4 (Reg. 2)	5.6	6.6	9	10	11.3	13.3	18
	kHz	kHz	kHz	kHz	kHz	kHz	kHz	kHz	kHz	kHz	kHz
13G	2 872 2 971 3 016	3 434 3 470	4 675*	5 469 5 475	5 574	6 586 6 613	8 822 8 885 8 900	10 006 10 021 10 036	11 369		
13H	2 899 2 965	3 455 3 485	4 657	5 463 5 472	5 484 5 547	6 598	8 825 8 906	10 036 10 045	11 282 11 300	13 267	
13I	2 860 2 878 2 887	3 419	4 678 4 693	5 451 5 466	5 496 5 523	6 574	8 873	10 051			
13J	2 857 2 863 2 878 2 890 2 920	3 410 3 428 3 458	4 684 4 696	5 451 5 454	5 559 5 568 5 577	6 550 6 559 6 580	8 816 8 843	10 012 10 018 10 042	11 276		
13K	2 863 2 932 3 004 3 019	3 401 3 458 3 464	4 663 4 672	5 463	5 481 5 547 5 577 5 604	6 547 6 553 6 580	8 843 8 849 8 945	10 009 10 018 10 042 10 060	11 339 11 366	13 309	
13M	2 908 2 977	3 437 3 449	4 660 4 690	5 463	5 502	6 574 6 628	8 837 8 867 8 903	10 066	11 378		
13N	2 986	3 443		5 457	5 508	6 604	8 828	10 093			
14	2 851 2 878	3 446 3 461 3 479			5 526 5 604	6 580 6 628	8 822 8 855 8 870	10 045 10 087	11 360	13 264	17 946
14A	2 950	3 413	4 678*			6 547 6 553	8 816 8 894				
14B		3 488	4 684*			6 535 6 604 6 673	8 900 8 954				
14C	2 887	3 452	4 684*			6 541 6 586	8 885 8 912				
14D	2 950	3 407	4 693*		5 481	6 559 6 574	8 843 8 858				
14E		3 413				6 565 6 616	8 891 8 945				
14F		3 488				6 526 6 610	8 825 8 831				
14G	2 869 2 944		4 678*		5 481 5 550 5 580		8 876 8 957				
VAFI	2 860	3 404			5 499	6 538	8 852	10 057		13 261	
VCAR	2 950				5 580				11 315		

(See cont.)

(Cont.)

Area	Frequency bands (MHz)											
	3	3.5	4.7	5.4 (Reg. 2)	5.6	6.6	9	10	11.3	13.3	18	22
	kHz	kHz	kHz	kHz	kHz	kHz	kHz	kHz	kHz	kHz	kHz	kHz
VEUR	2 998	3 413			5 640	6 580	8 957		11 378	13 264		
VMID	2 956				5 589		8 945			11 393		
VNAT	2 905	3 485			5 592	6 604	8 870	10 051		13 270 13 276		
VNCA		3 461	4 663		5 676			10 090		13 279		
VPAC	2 863					6 679	8 828			13 282		
VSAM	2 881				5 601			10 087		13 279		
VSEA	2 965	3 458			5 673	6 676	8 849		11 387	13 285		
W I	3 010		4 654 4 687		5 529 5 532 5 535 5 541	6 637 6 643	8 921 8 924 8 930 8 936	10 027 10 030 10 069 10 072 10 078	11 345 11 351	13 324 13 327 13 333 13 336 13 342 13 345 13 351	17 916 17 922 17 931	21 940 21 946 21 952 21 958 21 967 21 973 21 979 21 988 21 997
W II	3 007 3 013	3 494 3 497	4 654 4 687		5 529 5 538 5 544	6 637 6 640 6 646	8 927 8 933 8 936	10 027 10 033 10 075	11 342 11 348 11 354	13 330 13 339 13 348	17 919 17 925 17 934 17 940	21 964 21 985
W III	3 007		4 687			6 637	8 921 8 930	10 072 10 078	11 342 11 351	13 324 13 333 13 342 13 351	17 916 17 922 17 928 17 934 17 940	21 949 21 970
W IV	3 010				5 535 5 541	6 643	8 924	10 030 10 069	11 345	13 327 13 336 13 345	17 919 17 928 17 937	21 955 21 976 21 991
W V	3 013				5 532 5 538 5 544	6 640 6 646	8 927 8 933	10 033 10 075	11 348 11 354	13 330 13 339 13 348	17 925 17 931 17 937	21 943 21 961 21 982 21 994



ARTICLE 2

**Frequency allotment Plan  
(in numerical order of frequencies)**

*General Notes:*

27/214 1 Class of stations: FD

*Classes of emission:* see Nos. 27/56 to 27/59.

*Power:* Unless otherwise indicated in the Plan, the power values for aeronautical and aircraft stations are those shown in Nos. 27/60 to 27/68.

*Hours:* H24, unless otherwise indicated.

27/215 2 A frequency allotted on a “day-time basis” may be used during the period one hour after sunrise to one hour before sunset

27/216 3 A “common channel” is a channel allotted in common to two or more areas within interference distance of each other and its use is subject to agreement between the administrations concerned.

27/217 4 The world-wide frequency allotments appearing in the Tables at No. 27/213 and Nos. 27/218 to 27/231, except for carrier (reference) frequencies 3 023 kHz and 5 680 kHz, are reserved for assignment by administrations to stations operating under authority granted by the administration concerned, for the purpose of serving one or more aircraft operating agencies. Such assignments are to provide communications between an appropriate aeronautical station and an aircraft station anywhere in the world for exercising control over regularity of flight and for safety of aircraft. World-wide frequencies are not to be assigned by administrations for MWARA, RDARA and VOLMET purposes. Where the operational area of an aircraft lies wholly within a RDARA or Sub-RDARA boundary, frequencies allotted to those RDARAs and Sub-RDARAs shall be used.

27/218

Band 2 850-3 025 kHz

3 MHz

Frequency (kHz)	Authorized area of use*	Remarks*
1	2	3
2 851	M AFI R 2A 3B 3C 9C 11B 13E 13F 14	CC 3B 3C CC 13E 13F C001/2A
2 854	M SAT R 3A 3B 6E 10B	CC 3A 3B
2 857	R 2B 2C 6B 13J	CC 2B 2C
2 860	R 1B 3A 3C 9B 10B 12E 12J 13I V VAFI	CC 3A 3C CC 12E 12J C001/1B
2 863	R 2A 2C 7B 13C 13J 13K V VPAC	CC 2A 2C CC 13C 13J 13K
2 866	R 2C 3C 4B 6D 10A	C001/3C
2 869	M CEP R 2A 2B 3A 6G 10E 13C 14G	CC 2A 2B 3A C009/6G
2 872	M NAT R 3B 6A 6E 13G	CC 6A 6E
2 875	R 2A 2B 3A 6G 10A 12G	CC 2A 2B 3A C009/6G
2 878	M AFI R 3B 3C 11B 13I 13J 14	CC 3B3C CC 13I 13J
2 881	R 1B 2A 2B 3A 6C V VSAM	CC 2A 2B 3A C001/1B
2 884	R 2C 3B 6D	C001/3B
2 887	M CAR R 2A 2B 3A 7E 13I 14C	CC 2A2B 3A C001/2A 2B 3A
2 890	R 1B 6G 13J	
2 893	R 2C 3 4B 10D 12F	CC 2C 3
2 896	R 2A 2B 3A 6G	CC 2A 2B 3A C009/6G
2 899	M NAT R 5D 6G 13H	
2 902	R 2B 2C 3B 6G 12J	CC 2B 2C 3B C009/6G
2 905	R 3A 3C 5C 9B V VNAT	CC 3A 3C
2 908	R 2B 2C 3B 13M	CC 2B 2C 3B

\* See page AP27-75.

(See cont.)

(Cont.)

Frequency (kHz)	Authorized area of use*	Remarks*
1	2	3
2 911	R 3A 5B 6G 10A	C001/3A C010/6G
2 914	R 2B 2C 3B 13D	CC 2B 2C 3B
2 917	R 2A 6E 6G	C010/6G
2 920	R 2B 2C 6B 12C 13J	CC 2B 2C
2 923	R 3A 6A	C001/3A
2 926	R 2A 2C 4A 6F 10C 12J	CC 2A 2C C001/4A
2 929	R 2B 9B	C001/9B
2 932	M NP R 2A 2C 13K	CC 2A 2C
2 935	M SAT R 3 10D	
2 938	R 2 6G	C009/6G
2 941	R 2A 6F	
2 944	M MID SAM R 10A 10E 14G	
2 947	R 6A	
2 950	R 2 3C 7C 10F 12A 14A 14D V VCAR	CC 2 3C CC 14A 14D
2 953	R 4A 6G	
2 956	R 6C 7F 10A 12E 12F 12G 12H 13F V VMID	CC 12E 12F 12G 12H
2 959	R 3A	
2 962	M NAT R 6G	
2 965	R 1E 7B 10C 12F 12J 13H V VSEA	CC 12F 12J
2 968	R 3B 5B 6G	C001/3B C009/6G
2 971	M NAT R 5D 6G 13G	
2 974	R 1D 3C	
2 977	R 1C 6G 13M	

\* See page AP27-75.

(See cont.)

Band 2 850-3 025 kHz

3 MHz

(Cont.)

Frequency (kHz)	Authorized area of use*	Remarks*
1	2	3
2 980	R 1D 3C 12C	
2 983	R 1C 6G 13D	
2 986	R 3C 5A 13N	
2 989	R 1D 6G	
2 992	M MID R 10A 10E 13C	
2 995	R 6G	
2 998	M CWP R 7D 12E 12F 12G 12H 13F V VEUR	CC 12E 12F 12G 12H
3 001	R 6A 6E	CC 6A 6E
3 004	M NCA R 11B 13K	
3 007	W WORLDWIDE	C100/II III
3 010	W WORLDWIDE	C100/I IV
3 013	W WORLDWIDE	C100/II V
3 016	M EANAT R 9D 13G	
3 019	M NCA R 11B 13K	

27/219

Frequency (kHz)	Authorized area of use*	Remarks*
1	2	3
3 023	W WORLDWIDE (R) and (OR)	See Part II, Section II, Article 3

\* See page AP27-75.

Frequency (kHz)	Authorized area of use*	Remarks*
1	2	3
3 401	R 2B 2C 3B 9B 12C 13K	CC 2B 2C 3B C001/9B
3 404	R 3A 3C 9C 9D 10B V VAFI	CC 3A 3C CC 9C 9D
3 407	R 2B 2C 3B 7C 12D 14D	CC 2B 2C 3B
3 410	R 1D 3C 11B 13J	
3 413	M CEP R 3B 6G 13C 14A 14E V VEUR	CC 14A 14E C009/6G
3 416	R 1D 2A 2B 3A 6D	CC 2A 2B 3A C001/2A 2B 3A
3 419	M AFI R 3B 3C 9B 10D 12J 13I	CC 3B 3C
3 422	R 2A 2B 3A 6G	CC 2A 2B 3A C001/6G C004/6G
3 425	M AFI R 3B 3C 9B 10D 13D	CC 3B 3C
3 428	R 2B 2C 11B 13J	CC 2B 2C
3 431	R 3A 3B 5B 6G	CC 3A 3B C001/3A 3B C009/6G
3 434	R 2A 2C 6F 11B 13G	CC 2A 2C
3 437	R 3B 4A 6G 13M	C001/3B
3 440	R 2A 2C 6F 12	CC 2A 2C
3 443	R 3A 3B 4B 6E 11B 13N	CC 3A 3B
3 446	R 1D 6G 10E 13F 14	
3 449	R 2B 2C 6G 10A 13M	CC 2B 2C C001/6G C004/6G
3 452	M SAT R 3A 3C 5A 5C 14C	CC 3A 3C CC 5A 5C
3 455	M CAR CWP R 2A 2C 7B 13H	CC 2A 2C
3 458	R 1B 10D 13C 13J 13K V VSEA	CC 13C 13J 13K C001/1B
3 461	R 7F 9C 12E 12F 12G 12H 14 V VNCA	CC 12E 12F 12G 12H
3 464	R 1C 6G 12C 13K	

\* See page AP27-75.

(See cont.)

Band 3 400-3 500 kHz

3.5 MHz

(Cont.)

Frequency (kHz)	Authorized area of use*	Remarks*
1	2	3
3 467	M AFI MID SP R 10B 13D	CC AFI MID
3 470	M SEA R 1C 10A 13G	
3 473	M MID R 1B 6C 10E 13C	C001/1B
3 476	M INO NAT R 9B 13F	C001/9B
3 479	M EUR SAM R 6A 6B 14	
3 482	R 5D 6G	
3 485	M EA SEA R 7E 13H V VNAT	CC EA SEA
3 488	R 1B 5B 6B 10B 12E 12F 12G 12H 14B 14F	CC 12E 12F 12G 12H CC 14B 14F C001/1B
3 491	M EA R 1E 4A 10C 13E	CC 1E 4A
3 494	W WORLDWIDE	C100/II
3 497	W WORLDWIDE	C100/II

\* See page AP27-75.

Frequency (kHz)	Authorized area of use*	Remarks*
1	2	3
4 651	R 1D 6C 6G 10B 10E 13E 13F	CC 13E 13F C001/6G
4 654	W WORLDWIDE	C100/I II
4 657	M AFI CEP R 2A 2C 3B 6A 6E 13H	CC 2A 2C C001/2A 2C CC 6A 6E C001/6A 6E
4 660	R 2B 2C 9B 10C 13D 13M	CC 2B 2C CC 13D 13M
4 663	R 6G 10F 13E 13F 13K V VNCA	CC 13E 13F 13K C001/6G
4 666	M CWP R 1C 10B 10D 10E	CC 10B 10D 10E
4 669	M MID SAM R 6G 10C 10D	CC 10C 10D C001/6G
4 672	R 2A 2B 3A 4A 6G 11B 13K	CC 2A 2B 3A C001/4A C001/6G
4 675	M NAT R 6A 6E 9C 13G	CC 6A 6E C001/13G
4 678	M NCA R 10D 13I 14A 14G	CC 14A 14G C001/14A 14G
4 681	R 2B 2C 3B 10B 12E	CC 2B 2C 3B
4 684	R 3A 3C 10E 13J 14B 14C	CC 3A 3C CC 14B 14C C001/14B 14C
4 687	W WORLDWIDE	C100/I II III
4 690	R 2A 2B 3A 6G 10B 13M	CC 2A 2B 3A C001/6G
4 693	R 2B 2C 3 10B 12C 13I 14D	CC 2B 2C 3 C001/14D
4 696	R 2 6G 9 10 13J	C001/6G

\* See page AP27-75.

27/222 (WRC-2000)

Band 5 450-5 480 kHz (Reg. 2)

5.4 MHz

Frequency (kHz)	Authorized area of use*	Remarks*
1	2	3
5 451	R 10F 11B 12F 12H 13I 13J	CC 12F 12H CC 13I 13J
5 454	R 10 12E 13F 13J	
5 457	R 10C 13N	
5 460	R 10B 10E 12C 13D	
5 463	R 11B 13H 13K 13M	
5 466	R 10B 13I	
5 469	R 11B 13G	
5 472	R 10A 10D 13H	
5 475	R 10A 10D 12E 12F 13G	CC 12E 12F

27/223

Band 5 480-5 680 kHz

5.6 MHz

Frequency (kHz)	Authorized area of use*	Remarks*
1	2	3
5 481	R 2A 2C 4B 6G 7D 9C 10C 10E 12E 12J 13E 13F 13K 14D 14G	CC 2A 2C CC 10C 10E CC 12E 12J CC 13E 13F CC 14D 14G
5 484	R 1B 3A 3C 6A 9B 10A 10D 12C 12G 13H	CC 3A 3C
5 487	R 2C 6G 10C 12E	
5 490	R 2A 2B 3A 6D 10A 10D 12C 13C	CC 2A 2B 3A
5 493	M AFI R 3B 6G	C002/6G
5 496	R 2A 2B 3A 6F 10A 10D 12C 12J 13I	CC 2A 2B 3A
5 499	R 3B 6G V VAFI	C002/6G
5 502	R 2A 2B 3A 6B 10C 12C 13M	CC 2A 2B 3A
5 505	R 3B 6G	C003/6G
5 508	R 2B 2C 6F 7 9B 11B 12F 13N	CC 2B 2C
5 511	R 3A 5B 6G	C002/6G

\* See page AP27-75.

(See cont.)



(Cont.)

Frequency (kHz)	Authorized area of use*	Remarks*
1	2	3
5 514	R 2C 3B 3C 6E 11B 13C	CC 3B 3C
5 517	R 3A 6G	C002/6G
5 520	M CAR R 2B 2C 3B 6D 7E	CC 2B 2C 3B
5 523	R 2A 6G 9B 11B 12G 13I	
5 526	M SAM R 2B 2C 3B 5D 6E 10F 14	CC 2B 2C 3B
5 529	W WORLDWIDE	C100/I II
5 532	W WORLDWIDE	C100/I V
5 535	W WORLDWIDE	C100/I IV
5 538	W WORLDWIDE	C100/II V
5 541	W WORLDWIDE	C100/I IV
5 544	W WORLDWIDE	C100/II V
5 547	M CEP R 2A 4A 6G 7F 13H 13K	
5 550	M CAR R 2B 2C 3B 5D 6C 6E 14G	CC 2B 2C 3B
5 553	R 6G 10B 13C	
5 556	R 2 3 12F	CC 2 3
5 559	M SP R 2A 4A 6G 10E 12G 13J	
5 562	R 2C 3B 3C 10C 12D 13D	CC 3B 3C
5 565	M SAT R 6G 9B 10A	
5 568	R 1B 3A 3C 5B 6D 7F 10B 12 13J	CC 3A 3C
5 571	R 6G 11B 13C	
5 574	M CEP R 2B 2C 4B 6D 13G	CC 2B 2C
5 577	R 1C 5A 6G 7B 10E 13C 13J 13K	CC 13C 13J 13K
5 580	R 3A 3B 6A 6C 14G V VCAR	CC 3A 3B
5 583	R 1E 5A 5C 6G 7B 9 10B 12E 12F 12H 13E 13F	CC 5A 5C CC 12E 12F 12H CC 13E 13F
5 586	R 2C 3C 10D	

\* See page AP27-75.

(See cont.)

Band 5 480-5 680 kHz

5.6 MHz

(Cont.)

Frequency (kHz)	Authorized area of use*	Remarks*
1	2	3
5 589	R 12C V VMID	
5 592	R 6G 7C 9D V VNAT	
5 595	R 1C 2B 6B 10C 12E	
5 598	M NAT R 6G	
5 601	R 3A 3B 6A V VSAM	CC 3A 3B
5 604	R 2A 2C 4B 6G 10 12A 12E 12F 13E 13F 13K 14	CC 2A 2C CC 12E 12F CC 13E 13F
5 607	R 2B	
5 610	R 6G	
5 613	R 2B 12C	
5 616	M NAT R 6G	
5 619	R 2B 12J	
5 622	R 1D 6G	
5 625	R 3A 5B 6B 10D	
5 628	M NP R 1D 6G	C003/6G
5 631	R 6D 10A	
5 634	M INO R 6G	C002/6G
5 637	R 1D 3C	
5 640	R 6G V VEUR	C002/6G
5 643	M SP R 3C	
5 646	M NCA R 12G	
5 649	M NAT SEA	
5 652	M AFI CWP	
5 655	M EA SEA	CC EA SEA
5 658	M AFI MID	CC AFI MID

\* See page AP27-75.

(See cont.)

(Cont.)

Frequency (kHz)	Authorized area of use*	Remarks*
1	2	3
5 661	M CWP EUR	
5 664	M NCA	
5 667	M MID	
5 670	M EA	
5 673	V VSEA	
5 676	V VNCA	

27/224

Frequency (kHz)	Authorized area of use*	Remarks*
1	2	3
5 680	W WORLDWIDE (R) and (OR)	See Part II, Section II, Article 3

27/225

Frequency (kHz)	Authorized area of use*	Remarks*
1	2	3
6 526	R 2A 2B 3A 4A 6F 12G 14F	CC 2A 2B 3A
6 529	R 3B 6G	
6 532	M CWP R 2A 2B 3A 4A 12F	CC 2A 2B 3A
6 535	M SAT R 2C 5D 6G 9D 10A 10D 12C 12J 14B	
6 538	R 3A 3B 9B 11B V VAFI	CC 3A 3B
6 541	R 2C 6G 10C 13C 14C	
6 544	R 1C 3A 3B 5A 5C 6C 10D	CC 3A 3B CC 5A 5C

\* See page AP27-75.

(See cont.)

Band 6 525-6 685 kHz

6.6 MHz

(Cont.)

Frequency (kHz)	Authorized area of use*	Remarks*
1	2	3
6 547	R 2A 2C 5D 6G 9B 10B 10E 12E 12J 13F 13K 14A	CC 2A 2C CC 12E 12J
6 550	R 1B 3A 3C 5B 6D 11B 13J	CC 3A 3C
6 553	R 2A 2C 4B 6G 9 10 12E 12F 13E 13F 13K 14A	CC 2A 2C CC 12E 12F CC 13E 13F
6 556	M SEA R 1 3A 3C 10C 13C	CC 3A 3C
6 559	M AFI R 2A 3B 6G 11B 13J 14D	
6 562	M CWP R 2B 2C 10D 13C	CC 2B 2C
6 565	R 2A 4 6G 11B 14E	
6 568	R 2B 2C 3B 6D 7C 10C 13C	CC 2B 2C 3B
6 571	M EA R 12C	
6 574	M AFI R 2A 6G 10B 13I 13M 14D	
6 577	M CAR R 2B 2C 3B 4B 6D 13E	CC 2B 2C 3B
6 580	R 6G 7E 9C 10A 13C 13J 13K 14 V VEUR	CC 13C 13J 13K
6 583	R 2 3 6E	CC 2 3
6 586	M CAR R 2C 6G 7 13G 14C	
6 589	R 3	
6 592	M NCA R 12C	
6 595	R 1B 3B 3C 5B 6D	CC 3B 3C
6 598	M EUR R 4B 6G 9B 10B 10E 12E 13H	
6 601	R 2	
6 604	R 1D 6G 7C 10A 13N 14B V VNAT	
6 607	R 3A 6A 6B	
6 610	R 1D 6G 14F	
6 613	R 3A 6A 6B 13G	

\* See page AP27-75.

(See cont.)

(Cont.)

Frequency (kHz)	Authorized area of use*	Remarks*
1	2	3
6 616	R 4A 6G 12G 14E	
6 619	R 3A 6B	
6 622	M NAT R 6G 7F 9B 12C 13D	
6 625	M MID R 3B	
6 628	M NAT R 6G 7E 12C 13D 13M 14	CC 13D 13M
6 631	M MID R 3B 6C	
6 634	R 6G	
6 637	W WORLDWIDE	C100/I II III
6 640	W WORLDWIDE	C100/II V
6 643	W WORLDWIDE	C100/I IV
6 646	W WORLDWIDE	C100/II V
6 649	M SAM R 3A 6G	
6 652	R 6G 7B	
6 655	M NP R 2B 6E	
6 658	R 3C 6A	
6 661	M NP R 2B 6E	
6 664	R 3C 5A	
6 667	R 1E 2B 6F	
6 670	R 3C	
6 673	M AFI CEP R 2A 6G 10F 12D 13D 14B	
6 676	V VSEA	
6 679	V VPAC	
6 682	R 6G	

\* See page AP27-75.

27/226

Band 8 815-8 965 kHz

9 MHz

Frequency (kHz)	Authorized area of use*	Remarks*
1	2	3
8 816	R 4A 6G 12C 13J 14A	
8 819	R 2B 2C 9B 10 13C	CC 2B 2C
8 822	R 2A 3B 5A 5C 11B 13G 14	CC 5A 5C C005/2A
8 825	M NAT R 6G 13H 14F	
8 828	R 1D 13N V VPAC	
8 831	M NAT R 6G 13F 14F	
8 834	R 2B 2C 6C 7C 10 13C	CC 2B 2C
8 837	R 3A 3C 4A 9B 10B 13M	CC 3A 3C
8 840	R 1C 6	
8 843	M CEP R 5D 6G 10E 13C 13J 13K 14D	CC 13C 13J 13K
8 846	M CAR R 2 3 7F 9	CC 2 3
8 849	R 13K V VSEA	
8 852	R 3B 3C 9 12E V VAFI	CC 3B 3C
8 855	M SAM R 2 10A 14	
8 858	R 4A 6G 10D 13E 13F 14D	CC 13E 13F
8 861	M SAT R 3A 3B 6E 9B	CC 3A 3B C011/6E
8 864	M NAT R 2B 6B 6F 7E 13F	CC 6B 6F
8 867	M SP R 6G 10C 13D 13M	CC 13D 13M
8 870	R 5 6G 14 V VNAT	C004/6G
8 873	R 4 6G 9C 9D 12E 12F 13I	CC 9C 9D CC 12E 12F
8 876	R 2A 10A 12D 14G	

\* See page AP27-75.

(See cont.)

(Cont.)

Frequency (kHz)	Authorized area of use*	Remarks*
1	2	3
8 879	M INO NAT R 3B	
8 882	R 2C 6D	
8 885	R 5 6B 11B 13G 14C	
8 888	R 2 6G 7	C009/6G
8 891	M NAT R 6A 14E	
8 894	M AFI R 3C 12F 14A	
8 897	M EA	
8 900	R 3A 10D 13G 14B	
8 903	M AFI CWP R 10B 13M	
8 906	M NAT R 6A 6E 7B 9B 13H	CC 6A 6E
8 909	R 2A 6E	
8 912	R 5B 6G 11B 13D 14C	C004/6G
8 915	R 3C 5A	
8 918	M CAR MID R 6C	
8 921	W WORLDWIDE	C100/I III
8 924	W WORLDWIDE	C100/I IV
8 927	W WORLDWIDE	C100/II V
8 930	W WORLDWIDE	C100/I III
8 933	W WORLDWIDE	C100/II V
8 936	W WORLDWIDE	C100/I II
8 939	R 2A 2C 6F 10B 13C	CC 2A 2C
8 942	M SEA R 3A	
8 945	R 10F 13K 14E V VMID	
8 948	R 6A 12C	
8 951	M MID	
8 954	R 3 10E 12J 14B	
8 957	R 3B 6D 12C 13D 14G V VEUR	
8 960	R 6G 7F	

\* See page AP27-75.

27/227

Band 10 005-10 100 kHz

10 MHz

Frequency (kHz)	Authorized area of use*	Remarks*
1	2	3
10 006	R 6A 10 13G	
10 009	R 2B 2C 7B 9B 13K	CC 2B 2C
10 012	R 5 10 13J	
10 015	R 2 6C 12D	
10 018	M MID R 6G 9 13J 13K	CC 13J 13K C003/6G
10 021	R 1 6B 12C 13G	
10 024	M SAM R 2B 2C 3B 9B	CC 2B 2C 3B
10 027	W WORLDWIDE	C100/I II
10 030	W WORLDWIDE	C100/I IV
10 033	W WORLDWIDE	C100/II V
10 036	R 1E 6E 13G 13H	CC 13G 13H
10 039	R 3B 3C 4A 9B 12C	CC 3B 3C
10 042	M EA R 9C 10F 13C 13J 13K	CC 13C 13J 13K
10 045	R 2 3A 11B 13H 14	CC 2 3A
10 048	M NP R 2A 5D 13A 13B	CC 13A 13B
10 051	R 6A 6E 13I V VNAT	CC 6A 6E
10 054	R 2A 2C 6G 12	CC 2A 2C C004/6G
10 057	M CEP R 3A V VAFI	
10 060	R 1D 6F 13K	
10 063	R 4B 6G 12E	C004/6G
10 066	M SEA R 1B 10A 13M	
10 069	W WORLDWIDE	C100/I IV
10 072	W WORLDWIDE	C100/I III
10 075	W WORLDWIDE	C100/II V
10 078	W WORLDWIDE	C100/I III
10 081	M CWP R 4A 6A 7C 13F	C006/6A
10 084	M EUR SP R 6E 13D	

\* See page AP27-75.

(See cont.)



(Cont.)

Frequency (kHz)	Authorized area of use*	Remarks*
1	2	3
10 087	R 3 14 V VSAM	
10 090	R 12E 12F V VNCA	CC 12E 12F
10 093	R 5B 6B 11B 13N	
10 096	M NCA SAM R 7D	

Frequency (kHz)	Authorized area of use*	Remarks*
1	2	3
11 276	R 2A 2C 6G 10E 13J	CC 2A 2C C002/6G
11 279	M NAT R 2B 6F 9C	
11 282	M CEP R 4A 6G 13H	C003/6G
11 285	R 2A 3B 7	CC 2A 3B
11 288	R 5A 6G 11B	
11 291	M SAT R 3B 3C	CC 3B 3C
11 294	R 2A 6G 7C	C002/6G
11 297	R 2 12F	
11 300	M AFI R 6G 13H	C002/6G
11 303	R 3C 13E	
11 306	R 6G 7E 11B	
11 309	M NAT R 3A 6D	
11 312	R 5 9C 9D	CC 9C 9D
11 315	R 6G V VCAR	
11 318	R 3 4A 13D	

\* See page AP27-75.

(See cont.)

Band 11 275-11 400 kHz

11.3 MHz

(Cont.)

Frequency (kHz)	Authorized area of use*	Remarks*
1	2	3
11 321	R 6A 13F	
11 324	R 3A 3C 4B 12C	CC 3A 3C
11 327	M SP R 3B 5 13C	
11 330	M AFI NP R 3A 13F	
11 333	R 2B 2C 10	CC 2B 2C
11 336	M NAT R 3	
11 339	R 2B 6B 9 13K	
11 342	W WORLDWIDE	C100/II III
11 345	W WORLDWIDE	C100/I IV
11 348	W WORLDWIDE	C100/II V
11 351	W WORLDWIDE	C100/I III
11 354	W WORLDWIDE	C100/II V
11 357	R 6A 6E 10A	CC 6A 6E
11 360	M SAM R 2 3 14	CC 2 3
11 363	R 1 6E 10A	
11 366	R 1C 6B 6F 13K	CC 6B 6F
11 369	R 6G 13G	
11 372	R 2C 3B 6D	
11 375	M MID R 10A 13C	
11 378	R 3C 13M V VEUR	
11 381	R 6 12E 12J	CC 12E 12J
11 384	M CWP R 1D 12J	
11 387	M CAR V VSEA	
11 390	R 2 10	
11 393	R 9B 12E V VMID	
11 396	M CAR EA SEA	CC EA SEA

\* See page AP27-75.

Frequency (kHz)	Authorized area of use*	Remarks*
1	2	3
13 261	V VAFI	
13 264	R 14 V VEUR	
13 267	R 3 13H	
13 270	R 6G V VNAT	
13 273	M AFI	
13 276	R 6G V VNAT	
13 279	V VNCA VSAM	
13 282	V VPAC	
13 285	R 10 V VSEA	
13 288	M AFI EUR MID	CC AFI EUR MID
13 291	M NAT R 6	
13 294	M AFI	
13 297	M CAR EA SAM	CC CAR SAM
13 300	M CEP CWP NP SP R 4	CC CEP CWP NP SP
13 303	M EA NCA	CC EA NCA
13 306	M INO NAT	
13 309	M EA SEA R 13C 13K	CC EA SEA CC 13C 13K
13 312	M MID R 11B	
13 315	M NCA SAT	
13 318	M SEA R 13	
13 321	R 2 3	CC 2 3
13 324	W WORLDWIDE	C100/I III
13 327	W WORLDWIDE	C100/I IV
13 330	W WORLDWIDE	C100/II V
13 333	W WORLDWIDE	C100/I III
13 336	W WORLDWIDE	C100/I IV
13 339	W WORLDWIDE	C100/II V
13 342	W WORLDWIDE	C100/I III

\* See page AP27-75.

(See cont.)

Band 13 260-13 360 kHz

13.3 MHz

(Cont.)

Frequency (kHz)	Authorized area of use*	Remarks*
1	2	3
13 345	W WORLDWIDE	C100/I IV
13 348	W WORLDWIDE	C100/II V
13 351	W WORLDWIDE	C100/I III
13 354	R 5 7	CC 5 7
13 357	M SAT R 2	

27/230

Band 17 900-17 970 kHz

18 MHz

Frequency (kHz)	Authorized area of use*	Remarks*
1	2	3
17 901	R 12	
17 904	M CEP CWP NP SP R 4	CC CEP CWP NP SP
17 907	M CAR EA SAM SEA	CC CAR SAM CC EA SEA
17 910	R 10	
17 913	R 6G 13	
17 916	W WORLDWIDE	C100/I III
17 919	W WORLDWIDE	C100/II IV
17 922	W WORLDWIDE	C100/I III
17 925	W WORLDWIDE	C100/II V
17 928	W WORLDWIDE	C100/III IV
17 931	W WORLDWIDE	C100/I V
17 934	W WORLDWIDE	C100/II III
17 937	W WORLDWIDE	C100/IV V
17 940	W WORLDWIDE	C100/II III
17 943	R 6	
17 946	M NAT R 14	
17 949	R 5	

\* See page AP27-75.

(See cont.)

Band 17 900-17 970 kHz

18 MHz

(Cont.)

Frequency (kHz)	Authorized area of use*	Remarks*
1	2	3
17 952	R 3	
17 955	M SAT R 6B	
17 958	M NCA	
17 961	M AFI EUR INO MID	CC AFI EUR INO MID
17 964	R 2 11B	
17 967	R 5 13A 13B 13E 13F	CC 13A 13B 13E 13F

27/231

Band 21 924-22 000 kHz

22 MHz

Frequency (kHz)	Authorized area of use*	Remarks*
1	2	3
21 940	W WORLDWIDE	C100/I
21 943	W WORLDWIDE	C100/V
21 946	W WORLDWIDE	C100/I
21 949	W WORLDWIDE	C100/III
21 952	W WORLDWIDE	C100/I
21 955	W WORLDWIDE	C100/IV
21 958	W WORLDWIDE	C100/I
21 961	W WORLDWIDE	C100/V
21 964	W WORLDWIDE	C100/II
21 967	W WORLDWIDE	C100/I
21 970	W WORLDWIDE	C100/III
21 973	W WORLDWIDE	C100/I
21 976	W WORLDWIDE	C100/IV
21 979	W WORLDWIDE	C100/I
21 982	W WORLDWIDE	C100/V
21 985	W WORLDWIDE	C100/II
21 988	W WORLDWIDE	C100/I
21 991	W WORLDWIDE	C100/IV
21 994	W WORLDWIDE	C100/V
21 997	W WORLDWIDE	C100/I

\* See page AP27-75.

**Explanation of symbols and abbreviations**

Column 2	M = MWARA R = RDARA V = VOLMET W = worldwide
Column 3	CC = common channel to
C001/...	Restricted to daytime only, in the area indicated after the slant stroke
C002/6G	In area 6G, operation is restricted to east of 95° E
C003/6G	In area 6G, operation is restricted to west of 95° E
C004/6G	Use limited to east of 110° E
C005/2A	Use limited to north of 60° N
C006/6A	Use limited to east of 75° E
C007	Not used
C008	Not used
C009/6G	In area 6G, use limited to east of 110° E and south of 25° N
C010/6G	In area 6G, use limited to east of 118° E and north of 40° N
C011/6E	In area 6E, use is limited to south of 20° N
C100/...	Worldwide Allotment Area is indicated after the symbol. For assignment procedure see No. 27/217.

**ARTICLE 3****Frequencies for common use**

- 27/232** 1 The carrier (reference) frequencies 3 023 kHz and 5 680 kHz are intended for common use on a world-wide basis.
- 27/233** 2 The use of these frequencies in any part of the world is authorized:
- 2.1 aboard aircraft for:
- a)* communications with approach and aerodrome control;
- b)* communication with an aeronautical station when other frequencies of the station are either unavailable or unknown;
- 2.2 at aeronautical stations for aerodrome and approach control under the following conditions:
- a)* with mean power limited to a value of not more than 20 W in the antenna circuit;
- b)* special attention must be given in each case to the type of antenna used in order to avoid harmful interference;
- c)* the power of aeronautical stations which use these frequencies in accordance with the above conditions may be increased to the extent necessary to meet certain operational requirements subject to coordination between the administrations directly concerned and those whose services may be adversely affected.

**AP27-76**

**27/234** 3 Notwithstanding these provisions, the frequency 5 680 kHz may also be used at aeronautical stations for communication with aircraft stations when other frequencies of the aeronautical stations are either unavailable or unknown. However, this use shall be restricted to such areas and conditions that harmful interference cannot be caused to other authorized operations of stations in the aeronautical mobile service.

**27/235** 4 Additional particulars regarding the use of these channels for the above purposes may be recommended by the meetings of ICAO.

**27/236** 5 Frequencies 3 023 kHz and 5 680 kHz may also be used by stations of other mobile services participating in coordinated air-surface search and rescue operations, including communications between these stations and participating land stations. Aeronautical stations are authorized to use these frequencies to establish communications with such stations.

**27/237** 6 These channels may be used for A1A, A1B or A3E emissions, in accordance with special arrangements. Such channels shall not be subdivided.

**27/238** 7 All stations participating directly in coordinated search and rescue operations and using frequencies 3 023 kHz and 5 680 kHz shall transmit solely on the upper sideband except in the cases provided for in No. **27/57**.

## APPENDIX 30 (REV.WRC-19)\*

**Provisions for all services and associated Plans and List<sup>1</sup> for  
the broadcasting-satellite service in the frequency bands  
11.7-12.2 GHz (in Region 3), 11.7-12.5 GHz (in Region 1)  
and 12.2-12.7 GHz (in Region 2)** (WRC-03)

(See Articles 9 and 11) (WRC-03)

## TABLE OF CONTENTS

		<i>Page</i>
Article 1	General definitions .....	3
Article 2	Frequency bands.....	4
Article 2A	Use of the guardbands .....	4
Article 3	Execution of the provisions and associated Plans .....	5
Article 4	Procedures for modifications to the Region 2 Plan or for additional uses in Regions 1 and 3 .....	6
Article 5	Notification, examination and recording in the Master International Frequency Register of frequency assignments to space stations in the broadcasting-satellite service .....	19
Article 6	Coordination, notification and recording in the Master International Frequency Register of frequency assignments to terrestrial stations or to earth stations in the fixed-satellite service (Earth-to-space) affecting frequency assignments to broadcasting-satellite stations in the bands 11.7-12.2 GHz (in Region 3), 11.7-12.5 GHz (in Region 1) and 12.2-12.7 GHz (in Region 2) .....	23
Article 7	Coordination, notification and recording in the Master International Frequency Register of frequency assignments to stations in the fixed-satellite service (space-to-Earth) in the bands 11.7-12.2 GHz (in Region 2), 12.2-12.7 GHz (in Region 3) and 12.5-12.7 GHz (in Region 1), and to stations in the broadcasting-satellite service in the band 12.5-12.7 GHz (in Region 3) when frequency assignments to broadcasting-satellite stations in the bands 11.7-12.5 GHz in Region 1, 12.2-12.7 GHz in Region 2 and 11.7- 12.2 GHz in Region 3 are involved.....	24

\* The expression “frequency assignment to a space station”, wherever it appears in this Appendix, shall be understood to refer to a frequency assignment associated with a given orbital position. See also Annex 7 for the orbital limitations. (WRC-2000)

<sup>1</sup> The Regions 1 and 3 List of additional uses is annexed to the Master International Frequency Register (see Resolution 542 (WRC-2000)\*\*). (WRC-03)

\*\* *Note by the Secretariat:* This Resolution was abrogated by WRC-03.

*Note by the Secretariat:* Reference to an Article with the number in roman is referring to an Article in this Appendix.



Article 8	Miscellaneous provisions relating to the procedures .....	25
Article 9	(SUP - WRC-03)	
Article 10	The Plan for the broadcasting-satellite service in the frequency band 12.2-12.7 GHz in Region 2 .....	26
Article 11	Plan for the broadcasting-satellite service in the frequency bands 11.7-12.2 GHz in Region 3 and 11.7-12.5 GHz in Region 1 .....	65
Article 12	Relationship to Resolution <b>507 (REV.WRC-19)</b> .....	88
Article 13	Interference.....	88
Article 14	Period of validity of the provisions and associated Plans .....	88
ANNEXES		
Annex 1	Limits for determining whether a service of an administration is affected by a proposed modification to the Region 2 Plan or by a proposed new or modified assignment in the Regions 1 and 3 List or when it is necessary under this Appendix to seek the agreement of any other administration .....	89
Annex 2	Basic characteristics to be furnished in notices relating to space stations in the broadcasting-satellite service .....	94
Annex 3	Method for determining the limiting interfering power flux-density at the edge of a broadcasting-satellite service area in the frequency bands 11.7-12.2 GHz (in Region 3), 11.7-12.5 GHz (in Region 1) and 12.2-12.7 GHz (in Region 2) and for calculating the power flux-density produced in these bands by a terrestrial station, or by a transmitting earth station in the fixed-satellite service in the band 12.5-12.7 GHz .....	94
Annex 4	Need for coordination of a transmitting space station in the fixed-satellite service or in the broadcasting-satellite service where this service is not subject to a Plan: in Region 2 (11.7-12.2 GHz) with respect to the Plan, the List or proposed new or modified assignments in the List for Regions 1 and 3; in Region 1 (12.5-12.7 GHz) and in Region 3 (12.2-12.7 GHz) with respect to the Plan or proposed modifications to the Plan in Region 2; in Region 3 (12.2-12.5 GHz) with respect to the Plan, List or proposed new or modified assignments in the List for Region 1 .....	103
Annex 5	Technical data used in establishing the provisions and associated Plans and the Regions 1 and 3 List, which should be used for their application.....	105
Annex 6	Criteria for sharing between services .....	138
Annex 7	Orbital position limitations.....	144

## ARTICLE 1 (REV.WRC-03)

**General definitions**

1 For the purposes of this Appendix, the following terms shall have the meanings defined below:

1.1 *1977 Conference*: World Administrative Radio Conference for the Planning of the Broadcasting-Satellite Service in the Frequency Bands 11.7-12.2 GHz (in Regions 2 and 3) and 11.7-12.5 GHz (in Region 1), called in short World Broadcasting-Satellite Administrative Radio Conference (Geneva, 1977) (WARC-77).

1.2 *1983 Conference*: Regional Administrative Radio Conference for the Planning in Region 2 of the Broadcasting-Satellite Service in the Frequency Band 12.2-12.7 GHz and Associated Feeder Links in the Frequency Band 17.3-17.8 GHz, called in short Regional Administrative Conference for the Planning of the Broadcasting-Satellite Service in Region 2 (Geneva, 1983) (RARC Sat-R2).

1.3 *1985 Conference*: First Session of the World Administrative Radio Conference on the Use of the Geostationary-Satellite Orbit and the Planning of Space Services Utilizing It (Geneva, 1985), called in short WARC Orb-85.

1.3A *1997 Conference*: World Radiocommunication Conference (Geneva, 1997), called in short WRC-97.

1.3B *2000 Conference*: World Radiocommunication Conference (Istanbul, 2000), called in short WRC-2000.

1.4 *Regions 1 and 3 Plan*: The Plan for the broadcasting-satellite service in the frequency bands 11.7-12.2 GHz in Region 3 and 11.7-12.5 GHz in Region 1 contained in this Appendix.

1.5 *Region 2 Plan*: The Plan for the broadcasting-satellite service in the frequency band 12.2-12.7 GHz in Region 2 contained in this Appendix, together with any modifications resulting from the successful application of the procedures of Article 4.

1.6 *Frequency assignment in conformity with the Plan*:

- any frequency assignment which appears in the Regions 1 and 3 Plan; *or*
- any frequency assignment which appears in the Region 2 Plan or for which the procedure of Article 4 has been successfully applied.

1.7 *Additional use in Regions 1 and 3*: For the application of the provisions of this Appendix, additional uses in Regions 1 and 3 are:

- use of assignments with characteristics different from those appearing in the Regions 1 and 3 Plan and which are capable of causing more interference than the corresponding entries in the Plan;
- use of assignments in addition to those appearing in the Plan.

1.8 *Regions 1 and 3 List of additional uses (hereafter called in short the “List”):* The List of assignments for additional uses in Regions 1 and 3 as established by WRC-2000 (see Resolution **542 (WRC-2000)\***), as updated following the successful application of the procedure of § 4.1 of Article 4. (WRC-03)

1.9 *Frequency assignment in conformity with the List:* Any frequency assignment which appears in the List as updated following successful application of § 4.1 of Article 4. (WRC-03)

1.10 *The broadcasting-satellite service subject to one of the Plans:* The broadcasting-satellite service subject to one of the Plans referred to in this Appendix is the broadcasting-satellite service in the bands 11.7-12.5 GHz in Region 1, 12.2-12.7 GHz in Region 2 and 11.7-12.2 GHz in Region 3. (WRC-03)

## ARTICLE 2 (WRC-03)

### Frequency bands

2.1 The provisions of this Appendix apply to the broadcasting-satellite service in the frequency bands between 11.7 GHz and 12.2 GHz in Region 3, between 11.7 GHz and 12.5 GHz in Region 1 and between 12.2 GHz and 12.7 GHz in Region 2 and to the other services to which these bands are allocated in Regions 1, 2 and 3, insofar as their relationship to the broadcasting-satellite service in these bands is concerned.

2.2 (SUP - WRC-03)

## ARTICLE 2A (REV.WRC-19)

### Use of the guardbands<sup>1bis</sup>

2A.1 The use of the guardbands defined in § 3.9 of Annex 5 to provide space operation functions in accordance with No. **1.23** in support of the operation of geostationary-satellite networks in the broadcasting-satellite service (BSS) is not subject to the application of Section I of Article **9**.

2A.1.1 Coordination between assignments intended to provide the space operation functions and assignments of the BSS subject to a Plan shall be effected using the provisions of Article 7.

2A.1.2 Coordination among assignments intended to provide the space operation functions and services not subject to a Plan shall be effected using the provisions of Nos. **9.7, 9.17, 9.18** and the associated provisions of Section II of Article **9**, or § 4.1.1 *d*) or 4.2.3 *d*) of Article 4, as appropriate.

---

\* *Note by the Secretariat:* This Resolution was abrogated by WRC-03.

<sup>1bis</sup> The provisions of Resolution **49 (Rev.WRC-19)** do not apply. (WRC-19)

2A.1.3 Coordination of modifications to the Region 2 Plan or assignments to be included in the Regions 1 and 3 List with assignments intended to provide these functions shall be effected using § 4.1.1 *e*) or 4.2.3 *e*), as appropriate, of Article 4.

2A.1.4 Requests for the coordination referred to in §2A.1.1, 2A.1.2 and 2A.1.3 shall be sent by the requesting administration to the Bureau, together with the appropriate information listed in Appendix 4.

2A.2 Any assignment intended to provide these functions in support of a geostationary-satellite network in the BSS shall be notified under Article 11 and brought into use within the following time-limits<sup>1<sup>ter</sup></sup>: (WRC-15)

2A.2.1 *a*) for the case where the associated BSS assignments are contained in one of the initial Plans (Region 2 Plans incorporated in the Radio Regulations at WARC Orb-85 and the Regions 1 and 3 Plan adopted at WRC-2000), within the regulatory time-limit referred to in § 4.1.3 or § 4.2.6 of Article 4 from the date of receipt by the Bureau of the complete Appendix 4 data for those assignments intended to provide the space operation functions;

2A.2.2 *b*) for the case where the associated BSS assignments have been submitted under § 4.1.3 or § 4.2.6 of Article 4 for entry in the Regions 1 and 3 List or a modification to the Region 2 Plan, within the regulatory time-limit referred to in § 4.1.3 or § 4.2.6 of Article 4 for those associated BSS assignments;

2A.2.3 *c*) for the case where the associated BSS assignments have already been brought into use in accordance with the Radio Regulations, within the regulatory time-limit referred to in § 4.1.3 and § 4.2.6 of Article 4 from the date of receipt by the Bureau of the complete Appendix 4 data for those assignments intended to provide the space operation functions.

2A.3 Section II of Article 23 does not apply to assignments in the guardbands intended to provide the above-mentioned functions.

## ARTICLE 3 (WRC-2000)

### Execution of the provisions and associated Plans

3.1 The Member States in Regions 1, 2 and 3 shall adopt, for their broadcasting-satellite space stations<sup>2</sup> operating in the frequency bands referred to in this Appendix, the characteristics specified in the appropriate Regional Plan and the associated provisions.

3.2 The Member States shall not change the characteristics specified in the Regions 1 and 3 Plan or in the Region 2 Plan, or bring into use assignments to broadcasting-satellite space stations or to stations in the other services to which these frequency bands are allocated, except as provided for in the Radio Regulations and the appropriate Articles and Annexes of this Appendix.

---

<sup>1<sup>ter</sup></sup> The time-limit is established at the time when the request is received under § 2A.1.4. (WRC-15)

<sup>2</sup> Such stations may also be used for transmissions in the fixed-satellite service (space-to-Earth) in accordance with No. 5.492.

3.3 The Regions 1 and 3 Plan is based on national coverage from the geostationary-satellite orbit. The associated procedures contained in this Appendix are intended to promote long-term flexibility of the Plan and to avoid monopolization of the planned bands and orbit by a country or a group of countries.

ARTICLE 4 (REV.WRC-19)

**Procedures for modifications to the Region 2 Plan or for additional uses in Regions 1 and 3<sup>3</sup>**

**4.1 Provisions applicable to Regions 1 and 3**

4.1.1 An administration proposing to include a new or modified assignment in the List shall seek the agreement of those administrations whose services are considered to be affected, i.e. administrations:

- a) of Regions 1 and 3 having a frequency assignment to a space station in the broadcasting-satellite service which is included in the Regions 1 and 3 Plan with a necessary bandwidth, any portion of which falls within the necessary bandwidth of the proposed assignment; *or*
- b) of Regions 1 and 3 having a frequency assignment included in the List or for which complete Appendix 4 information has been received by the Radiocommunication Bureau in accordance with the provisions of § 4.1.3, and any portion of which falls within the necessary bandwidth of the proposed assignment; *or*
- c) of Region 2 having a frequency assignment to a space station in the broadcasting-satellite service which is in conformity with the Region 2 Plan, or in respect of which proposed modifications to that Plan have been received by the Bureau in accordance with the provisions of § 4.2.6 with a necessary bandwidth, any portion of which falls within the necessary bandwidth of the proposed assignment; *or*
- d) having no frequency assignment in the broadcasting-satellite service with a necessary bandwidth, any portion of which falls within the necessary bandwidth of the proposed assignment, but in whose territory the power flux-density value exceeds the prescribed limit as a result of the proposed assignment, or having an assignment whose associated service area does not cover the whole of the territory of the administration, and in whose territory outside that service area the power flux-density from the proposed assignment exceeds the prescribed limit as a result of the proposed assignment; *or*
- e) having a frequency assignment in the band 11.7-12.2 GHz in Region 2 or 12.2-12.5 GHz in Region 3 to a space station in the fixed-satellite service which is recorded in the Master International Frequency Register (Master Register) or for which complete coordination information has been received by the Bureau for coordination under No. 9.7, or under § 7.1 of Article 7.

---

<sup>3</sup> The provisions of Resolution 49 (Rev.WRC-15) apply. (WRC-15)

4.1.2 The services of an administration are considered to be affected when the limits shown in Annex 1 are exceeded.

4.1.3 An administration, or one<sup>4</sup> acting on behalf of a group of named administrations, intending to include a new or modified assignment in the List shall send to the Bureau, not earlier than eight years but preferably not later than two years before the date on which the assignment is to be brought into use, the relevant information listed in Appendix 4. An assignment in the List shall lapse if it is not brought into use within eight years after the date of receipt by the Bureau of the relevant complete information<sup>5</sup>. A proposed new or modified assignment not included in the List within eight years after the date of receipt by the Bureau of the relevant complete information shall also lapse<sup>5</sup>. (WRC-07)

4.1.3*bis* The regulatory time-limit for bringing into use of an assignment in the List may be extended once by not more than three years due to launch failure in the following cases:

- the destruction of the satellite intended to bring the assignment into use;
- the destruction of the satellite launched to replace an already operating satellite which is intended to be relocated to bring another assignment into use; *or*
- the satellite is launched, but fails to reach its assigned orbital location.

For this extension to be granted, the launch failure must have occurred at least five years after the date of receipt of the complete Appendix 4 data. In no case shall the period of the extension of the regulatory time-limit exceed the difference in time between the three-year period and the period remaining from the date of the launch failure to the end of the regulatory time-limit<sup>6</sup>. In order to take advantage of this extension, the administration shall have, within one month of the launch failure or one month after 5 July 2003, whichever comes later, notified the Bureau in writing of such failure, and shall also provide the following information to the Bureau before the end of the regulatory time-limit of § 4.1.3:

- date of launch failure;
- due diligence information as required in Resolutions 49 (Rev.WRC-15) for the assignment with respect to the satellite that suffered the launch failure, if that information has not already been provided.

If, 11 months after the request for extension, the administration has not provided to the Bureau updated Resolution 49 (Rev.WRC-15) information, the Bureau shall promptly send a reminder to the notifying administration. If, within one year of the request for extension, the administration has not provided to the Bureau updated Resolution 49 (Rev.WRC-15) information for the new satellite under procurement, the related frequency assignments shall lapse. (WRC-15)

---

<sup>4</sup> Whenever, under this provision, an administration acts on behalf of a group of named administrations, all members of that group retain the right to respond in respect of their own networks or systems. (WRC-03)

<sup>5</sup> The provisions of Resolution 533 (Rev.WRC-2000)\* apply. (WRC-03)

\* *Note by the Secretariat:* This Resolution was abrogated by WRC-12.

<sup>6</sup> For a launch failure which occurred before 5 July 2003, the maximum extension of three years shall apply as from 5 July 2003. (WRC-03)

4.1.4 If the information received by the Bureau under § 4.1.3 is found to be incomplete, the Bureau shall immediately seek from the administration concerned any clarification required and information not provided.

4.1.5 The Bureau shall determine, on the basis of Annex 1, the administrations whose frequency assignments are considered to be affected. The Bureau shall publish<sup>7</sup>, in a Special Section of its International Frequency Information Circular (BR IFIC), the complete information received under § 4.1.3, together with the names of the affected administrations, the corresponding fixed-satellite service networks, the corresponding broadcasting-satellite service assignments and terrestrial stations, as appropriate. The Bureau shall immediately send a telegram/fax to the administration proposing the assignment, drawing its attention to the information contained in the relevant BR IFIC. (WRC-07)

4.1.6 The Bureau shall send a telegram/fax to the administrations listed in the Special Section of the BR IFIC, drawing their attention to the information it contains. (WRC-07)

4.1.7 An administration which considers that it should have been identified in the publication referred to under § 4.1.5 above shall, within four months of the date of publication of its relevant BR IFIC, and giving the technical reasons for so doing, request the Bureau to include its name in the publication. The Bureau shall study this information on the basis of Annex 1 and shall inform both administrations of its conclusions. Should the Bureau agree to the administration's request, it shall publish an addendum to the publication under § 4.1.5.

4.1.7*bis* Except as provided under § 4.1.18 to 4.1.20, any inclusion of a new or modified frequency assignment in the Regions 1 and 3 List which would have the effect of exceeding the limits specified in Annex 1 shall be subject to the agreement of all administrations whose services are considered to be affected. (WRC-03)

4.1.8 The administration seeking agreement or the administration with which agreement is sought may request any additional technical information it considers necessary. The administrations shall inform the Bureau of such requests.

4.1.9 Comments from administrations identified in the publication referred to under § 4.1.5 above shall be sent to the Bureau and to the administration proposing the modification. (WRC-15)

4.1.10 An administration that has not notified its agreement either to the administration seeking agreement or to the Bureau within a period of four months following the date of the BR IFIC referred to in § 4.1.5 shall be deemed to have not agreed to the proposed assignment unless the provisions of § 4.1.10a to 4.1.10d and § 4.1.21 are applied. This time-limit may be extended:

- for an administration that has requested additional information under § 4.1.8, by up to three months; *or*
- for an administration that has requested the assistance of the Bureau under § 4.1.21, by up to three months following the date at which the Bureau communicated the result of its action. (WRC-15)

---

<sup>7</sup> If the payments are not received in accordance with the provisions of Council Decision 482, as amended, on the implementation of cost recovery for satellite network filings, the Bureau shall cancel the publication, after informing the administration concerned. The Bureau shall inform all administrations of such action and that the network specified in the publication in question no longer has to be taken into consideration by the Bureau and other administrations. The Bureau shall send a reminder to the notifying administration not later than two months prior to the deadline for the payment in accordance with the above-mentioned Council Decision 482 unless the payment has already been received. (WRC-07)

4.1.10<sup>bis</sup> Thirty days prior to the expiry of the same four-month period, the Bureau shall dispatch a reminder telegram or fax to an administration which has not made its comments under § 4.1.10, bringing the matter to its attention. (WRC-03)

4.1.10<sup>ter</sup> (SUP - WRC-15)

4.1.10a After the same time period as specified in § 4.1.10, the notifying administration may, pursuant to § 4.1.21, request the Bureau to assist in respect of an administration which has not replied within this time period. (WRC-15)

4.1.10b The Bureau, acting under § 4.1.10a, shall send a reminder to the administration which has not replied, together with the results of its previously published compatibility analysis, containing the change in the values referred to in paragraph 1b of Annex 1 to Appendix 30, requesting a decision. (WRC-15)

4.1.10c Fifteen days before the expiry of the 30-day period referred to in § 4.1.10d, the Bureau shall send a reminder to the above-mentioned administration drawing its attention to the consequence of no reply. (WRC-15)

4.1.10d If no decision is communicated to the Bureau within 30 days after the date of dispatch of the reminder under § 4.1.10b, it shall be deemed that the administration which has not given a decision has agreed to the proposed assignment. (WRC-15)

4.1.11 If, in seeking agreement, an administration modifies its initial proposal, it shall again apply the provisions of § 4.1 and the subsequent procedure in cases where:

- the assignments of any other administration received by the Bureau in accordance with § 4.1.3 or § 4.2.6, or § 2A.1.4 of Article 2A, or § 7.1 of Article 7, or No. 9.7 before this modified proposal is received under § 4.1.12;
- the assignments of any other administration contained in the Plans or the Lists; *or*
- the terrestrial services of any other administration,

are considered as being affected and receive more interference as a result of the modifications than that produced by the initial proposal. (WRC-15)

4.1.12<sup>7bis</sup> If agreement has been reached with the administrations identified in the publication referred to under § 4.1.5 above, the administration proposing the new or modified assignment may continue with the appropriate procedure in Article 5, and shall so inform the Bureau, indicating the final characteristics of the frequency assignment together with the names of the administrations with which agreement has been reached. (WRC-19)

4.1.12<sup>bis</sup> In application of § 4.1.12, an administration may indicate the changes to the information communicated to the Bureau under § 4.1.3 and published under § 4.1.5. In submitting such information, noting the requirements of § 5.1.2, the administration may also request the Bureau to examine the submission in respect of notification under § 5.1.1. (WRC-19)

---

<sup>7bis</sup> For any remaining affected networks whose assignments were entered in the List before the notice received under § 4.1.12, the Bureau shall use the method in Annex 1 to further examine if the remaining corresponding assignments in the List are still considered as being affected. The examination in respect of those remaining affected networks is conducted independently using the Appendices 30 and 30A master database corresponding to the Part B Special Section that was published under § 4.1.15. Resolution 548 (Rev.WRC-12) applies. (WRC-19)



## AP30-10

4.1.13 The agreement of the administrations affected may also be obtained in accordance with this Article, for a specified period. When this specific period of agreement expires for an assignment in the List, the assignment in question shall be maintained in the List until the end of the period referred to in § 4.1.3 above. After that date this assignment shall lapse unless the agreement of the administrations affected is renewed<sup>7ter</sup>. (WRC-19)

4.1.14 Where the proposed assignment involves developing countries, administrations shall seek all practicable solutions conducive to the economical development of the broadcasting-satellite systems of these countries.

4.1.15 The Bureau shall publish<sup>8</sup> in a Special Section of its BR IFIC the information received under § 4.1.12, together with the names of any administrations with which the provisions of this Article have been successfully applied. The frequency assignment concerned shall be included in the List. (WRC-03)

4.1.16 In case of disagreement on the part of an administration whose agreement has been sought, the requesting administration shall first endeavour to solve the problem by exploring all possible means of meeting its requirement. If the problem still cannot be solved by such means, the administration whose agreement has been sought should endeavour to overcome the difficulties as far as possible, and shall state the technical reasons for any disagreement if the administration seeking the agreement requests it to do so. (WRC-19)

4.1.17 If no agreement is reached between the administrations concerned, the Bureau shall carry out any study that may be requested by either one of these administrations; the Bureau shall inform them of the result of the study and shall make such recommendations as it may be able to offer for the solution of the problem.

4.1.18 If, in spite of the application of § 4.1.16 and 4.1.17, there is still continuing disagreement and the assignment which was the basis of the disagreement is not an assignment in the Regions 1 and 3 Plan, or in the Region 2 Plan or for which the procedure of § 4.2 has been initiated, and if the notifying administration insists that the proposed assignment be included in the Regions 1 and 3 List, the Bureau shall provisionally enter the assignment in the Regions 1 and 3 List with an indication of those administrations whose assignments were the basis of the disagreement; however, the entry shall be changed from provisional to definitive recording in the List only if the Bureau is informed that the new assignment in the Regions 1 and 3 List has been in use, together with the assignment which was the basis for the disagreement, for at least four months without any complaint of harmful interference being made. (WRC-03)

---

<sup>7ter</sup> Unless the Bureau has been informed by the notifying administration of the renewal of the agreement, it shall, no later than six months before the end of the specified period, send a reminder to the notifying administration. (WRC-19)

<sup>8</sup> If the payments are not received in accordance with the provisions of Council Decision 482, as amended, on the implementation of cost recovery for satellite network filings, the Bureau shall cancel the publication, after informing the administration concerned. The Bureau shall inform all administrations of such action and that the network specified in the publication in question no longer has to be taken into consideration by the Bureau and other administrations. The Bureau shall send a reminder to the notifying administration not later than two months prior to the deadline for the payment in accordance with the above-mentioned Council Decision 482 unless the payment has already been received. (WRC-07)

4.1.18*bis* When requesting the application of § 4.1.18, the notifying administration shall undertake to meet the requirements of § 4.1.20 and provide to the administration in respect of which § 4.1.18 is applied, with a copy to the Bureau, a description of the steps by which it undertakes to meet these requirements. Once an assignment is entered in the List provisionally under the provisions of § 4.1.18, the calculation of the equivalent protection margin (EPM)<sup>9</sup> of an assignment in the Regions 1 and 3 List or for which the procedure of Article 4 has been initiated and which was the basis for the disagreement shall not take into account the interference produced by the assignment for which the provisions of § 4.1.18 have been applied. When the recording of an assignment entered into the List is changed from provisional to definitive in accordance with § 4.1.18, but there is still continuing disagreement between the administrations, the Bureau shall consult with the administration responsible for the assignments which were the basis for the disagreement in determining the appropriate course of action as regards any update to the EPM for the assignments which were the basis for the disagreement. (WRC-19)

4.1.19 Should the assignments that were the basis of the disagreement not be brought into use within the period specified in No. **11.44** (for non-planned services), or in § 4.1 (for assignments in the List or having initiated the procedure under § 4.1), as appropriate, then the status of the assignment in the List shall be reviewed accordingly.

4.1.20 Should harmful interference be caused by an assignment included in the List under § 4.1.18 to any recorded assignment in the Master Register which was the basis of the disagreement, the administration using the frequency assignment included in the List under § 4.1.18 shall, upon receipt of advice thereof, immediately eliminate this harmful interference.

4.1.21 An administration may, at any stage in the procedure described, or before applying it, request the assistance of the Bureau.

4.1.22 The relevant provisions of Article 5 shall be applied when frequency assignments are notified to the Bureau.

4.1.23 When a frequency assignment included in the List is no longer required, the administration concerned shall immediately so inform the Bureau. The Bureau shall publish this information in a Special Section of its BR IFIC and delete the assignment from the List.

4.1.24 No assignment in the List shall have a period of operation exceeding 15 years, counted from the date of bringing into use, or 2 June 2000, whichever is later. Upon request by the responsible administration received by the Bureau at the latest three years before the expiry of this period, this period may be extended by up to 15 years, on condition that all the characteristics of the assignment remain unchanged<sup>9*bis*</sup>. (WRC-19)

---

<sup>9</sup> For the definition of EPM, see § 3.4 of Annex 5. (WRC-03)

<sup>9*bis*</sup> Unless the request has been received by the Bureau, it shall, no later than 90 days before the deadline of such a request, send a reminder to the notifying administration. (WRC-19)

4.1.25 Where an administration already having included in the List two assignments (not including those systems notified on behalf of a group of named administrations and included in the List by WRC-2000), in the same channel and covering the same service area, proposes to include in the List a new assignment in the same channel over this same service area, it shall apply the following in respect of another administration which has no assignment in the List in the same channel and which proposes to include in the List a new assignment:

- a) if the agreement of the former administration is required following the application of § 4.1 by the latter administration, in order to protect the new assignment proposed by the former administration from interference caused by the assignment proposed by the latter administration, both administrations shall make every possible effort to resolve the difficulties by means of mutually acceptable adjustments to their networks;
- b) in case of continuing disagreement, and if the former administration has not communicated to the Bureau the information specified in Annex 2 to Resolution 49 (Rev.WRC-15), this administration shall be deemed to have given its agreement to inclusion in the List of the assignment of the latter administration. (WRC-15)

4.1.26 The procedure of this Article may be applied by the administration of a new ITU Member State in order to include new assignments in the List. Upon completion of the procedure, the next World Radiocommunication Conference may be requested to consider, among the assignments included in the List after the successful completion of this procedure, the inclusion in the Plan of up to 10 channels (for Region 1) and up to 12 channels (for Region 3), over the national territory of the new Member State. (WRC-03)

4.1.27 When an administration has successfully applied this procedure and received all the agreements<sup>10</sup> required to include in the List assignments over its national territory, at an orbital location and/or in channels different from those appearing in the Plan for its country, it may request the next world radiocommunication conference to consider the inclusion in the Plan of up to 10 (for Region 1) and up to 12 (for Region 3) of these assignments, in replacement of its assignments appearing in the Plan.

4.1.27bis Should the assignments mentioned in § 4.1.26 and 4.1.27 over the national territory of the administration not be brought into use within the regulatory time-limit mentioned in § 4.1.3, they would be retained in the List until the end of the world radiocommunication conference immediately following the successful completion of the procedure referred to in § 4.1.26 and 4.1.27 respectively, and thereafter they shall be removed from the List. (WRC-03)

4.1.28 The List, as updated, shall be published periodically by the Bureau.

4.1.29 New or modified assignments in the List shall be limited to digital modulation.

---

<sup>10</sup> In such a case, § 4.1.18 does not apply.

## 4.2 Provisions applicable to Region 2

4.2.1 When an administration intends to make a modification<sup>11</sup> to the Region 2 Plan, i.e.:

- a) to modify the characteristics of any of its frequency assignments to a space station in the broadcasting-satellite service which are shown in the Region 2 Plan, or for which the procedure in this Article has been successfully applied, whether or not the station has been brought into use; *or*
- b) to include in the Region 2 Plan a new frequency assignment to a space station in the broadcasting-satellite service; *or*
- c) to cancel a frequency assignment to a space station in the broadcasting-satellite service,

the following procedure shall be applied before any notification of the frequency assignment is made to the Bureau (see Article 5).

4.2.2 The term “frequency assignment in conformity with the Plan” used in this and the following Articles is defined in Article 1.

4.2.3 An administration proposing a modification to the characteristics of a frequency assignment in conformity with the Region 2 Plan, or the inclusion of a new frequency assignment in that Plan, shall seek the agreement of those administrations:

- a) of Regions 1 and 3 having a frequency assignment to a space station in the broadcasting-satellite service which is in conformity with the Regions 1 and 3 Plan with a necessary bandwidth, any portion of which falls within the necessary bandwidth of the proposed assignment; *or*
- b) of Regions 1 and 3 having a frequency assignment included in the List or for which complete Appendix 4 information has been received by the Bureau in accordance with the provisions of § 4.1.3, and any portion of which falls within the necessary bandwidth of the proposed assignment; *or*
- c) of Region 2 having a frequency assignment in the Region 2 Plan to a space station in the broadcasting-satellite service in the same or adjacent channel which is in conformity with that Plan, or in respect of which proposed modifications to that Plan have been received by the Bureau in accordance with the provisions of § 4.2.6; *or*
- d) having no frequency assignment in the broadcasting-satellite service in the channel concerned, but in whose territory the power flux-density value exceeds the prescribed limit as a result of the proposed modification, or having an assignment whose associated service area does not cover the whole of the territory of the administration, and in whose territory outside that service area the power flux-density from the broadcasting-satellite space station subject to this modification exceeds the prescribed limit as a result of the proposed modification; *or*

---

<sup>11</sup> For assignments using analogue modulation, the intention not to employ energy dispersal in accordance with § 3.18 of Annex 5 shall be treated as a modification and thus subject to the appropriate provisions of this Article.

## AP30-14

- e) having a frequency assignment in the band 12.5-12.7 GHz in Region 1 or 12.2-12.7 GHz in Region 3 to a space station in the fixed-satellite service which is recorded in the Master Register, or for which complete coordination information has been received by the Bureau for coordination under No. 9.7 or under § 7.1 of Article 7; *or*
- f) having a frequency assignment to a space station in the broadcasting-satellite service in the frequency band 12.5-12.7 GHz in Region 3 with a necessary bandwidth, any portion of which falls within the necessary bandwidth of the proposed assignment, and:
  - which is recorded in the Master Register; *or*
  - for which complete coordination information has been received by the Bureau for coordination under No. 9.7 or under § 7.1 of Article 7;
- g) whose services are considered to be affected.

4.2.4 Not used.

4.2.5 The services of an administration are considered to be affected when the limits shown in Annex 1 are exceeded.

4.2.6 An administration, or one<sup>13</sup> acting on behalf of a group of named administrations, intending to make a modification to the Region 2 Plan shall send to the Bureau, not earlier than eight years but preferably not later than two years before the date on which the assignment is to be brought into use, the relevant information listed in Appendix 4. Modifications to that Plan shall lapse if the assignment is not brought into use within eight years after the date of receipt by the Bureau of the relevant complete information<sup>14</sup>. A request for a modification that has not been included in that Plan within eight years after the date of receipt by the Bureau of the relevant complete information shall also lapse<sup>14</sup>. (WRC-07)

4.2.6bis The regulatory time-limit for bringing into use of an assignment in the Region 2 Plan obtained through application of § 4.2 may be extended once by not more than three years due to launch failure in the following cases:

- the destruction of the satellite intended to bring the assignment into use;
- the destruction of the satellite launched to replace an already operating satellite which is intended to be relocated to bring another assignment into use; *or*
- the satellite is launched, but fails to reach its assigned orbital location.

---

<sup>12</sup> (SUP – WRC-19)

<sup>13</sup> Whenever, under this provision, an administration acts on behalf of a group of named administrations, all members of that group retain the right to respond in respect of their own networks or systems. (WRC-03)

<sup>14</sup> The provisions of Resolution 533 (Rev.WRC-2000)\*\* apply. (WRC-03)

\*\* *Note by the Secretariat:* This Resolution was abrogated by WRC-12.

For this extension to be granted, the launch failure must have occurred at least five years after the date of receipt of the complete Appendix 4 data. In no case shall the period of the extension of the regulatory time-limit exceed the difference in time between the three-year period and the period remaining from the date of the launch failure to the end of the regulatory time-limit<sup>15</sup>. In order to take advantage of this extension, the administration shall have, within one month of the launch failure or one month after 5 July 2003, whichever comes later, notified the Bureau in writing of such failure, and shall also provide the following information to the Bureau before the end of the regulatory time-limit of § 4.2.6:

- date of launch failure;
- due diligence information as required in Resolution 49 (Rev.WRC-15) for the assignment with respect to the satellite that suffered the launch failure, if that information has not already been provided.

If, 11 months after the request for extension, the administration has not provided to the Bureau updated Resolution 49 (Rev.WRC-15) information, the Bureau shall promptly send a reminder to the notifying administration. If, within one year of the request for extension, the administration has not provided to the Bureau updated Resolution 49 (Rev.WRC-15) information for the new satellite under procurement, the related frequency assignments shall lapse. (WRC-15)

4.2.7 If the information received by the Bureau under § 4.2.6 is found to be incomplete, the Bureau shall immediately seek from the administration concerned any clarification required and information not provided.

4.2.8 The Bureau shall determine, on the basis of Annex 1, the administrations whose frequency assignments are considered to be affected within the meaning of § 4.2.3. The Bureau shall publish<sup>16</sup>, in a Special Section of its BR IFIC, the complete information received under § 4.2.6, together with the names of the affected administrations, the corresponding fixed-satellite service networks, the corresponding broadcasting-satellite service assignments and terrestrial stations, as appropriate. The Bureau shall immediately send a telegram/fax to the administration proposing the modification to the Region 2 Plan, drawing its attention to the information contained in the relevant BR IFIC. (WRC-07)

4.2.9 The Bureau shall send a telegram/fax to the administrations listed in the Special Section of its BR IFIC, drawing their attention to the information it contains. (WRC-07)

---

<sup>15</sup> For a launch failure which occurred before 5 July 2003, the maximum extension of three years shall apply as from 5 July 2003. (WRC-03)

<sup>16</sup> If the payments are not received in accordance with the provisions of Council Decision 482, as amended, on the implementation of cost recovery for satellite network filings, the Bureau shall cancel the publication, after informing the administration concerned. The Bureau shall inform all administrations of such action and that the network specified in the publication in question no longer has to be taken into consideration by the Bureau and other administrations. The Bureau shall send a reminder to the notifying administration not later than two months prior to the deadline for the payment in accordance with the above-mentioned Council Decision 482 unless the payment has already been received. (WRC-07)

4.2.10 An administration which considers that it should have been included in the publication referred to under § 4.2.8 above shall, within four months of the date of publication in the relevant BR IFIC, and giving the technical reasons for so doing, request the Bureau to include its name in the publication. The Bureau shall study this information on the basis of Annex 1 and shall inform both administrations of its conclusions. Should the Bureau agree to the administration's request, it shall publish an addendum to the publication under § 4.2.8. (WRC-07)

4.2.11 Except as provided under § 4.2.21A to 4.2.21D, any modification to a frequency assignment which is in conformity with the Region 2 Plan or any inclusion in that Plan of a new frequency assignment which would have the effect of exceeding the limits specified in Annex 1 shall be subject to the agreement of all administrations whose services are considered to be affected. (WRC-03)

4.2.12 The administration seeking agreement or the administration with which agreement is sought may request any additional technical information it considers necessary. The administrations shall inform the Bureau of such requests.

4.2.13 Comments from administrations on the information published pursuant to § 4.2.8 should be sent either directly to the administration proposing the modification or through the Bureau. In any event, the Bureau shall be informed that comments have been made.

4.2.14 An administration that has not notified its comments either to the administration seeking agreement or to the Bureau within a period of four months following the date of the BR IFIC referred to in § 4.2.8 shall be deemed to have agreed to the proposed assignment. This time-limit may be extended by up to three months for an administration that has requested additional information under § 4.2.12 or for an administration that has requested the assistance of the Bureau under § 4.2.22. In the latter case, the Bureau shall inform the administrations concerned of this request.

4.2.14*bis* Thirty days prior to the expiry of the same four-month period the Bureau shall dispatch a reminder telegram or fax to an administration which has not made its comments under § 4.2.14, bringing the matter to its attention. (WRC-03)

4.2.14*ter* After expiry of the deadline for comments in respect of the proposed assignment, the Bureau shall, according to its records, publish a Special Section, indicating the list of administrations whose agreements are required for completion of the Article 4 procedure. (WRC-03)

4.2.15 If, in seeking agreement, an administration modifies its initial proposal, it shall again apply the provisions of § 4.2 and the consequent procedure with respect to any other administration whose services might be affected as a result of modifications to the initial proposal.

4.2.16<sup>16bis</sup> If no comments have been received on the expiry of the periods specified in § 4.2.14, or if agreement has been reached with the administrations which have made comments and with which agreement is necessary, the administration proposing the modification may continue with the appropriate procedure in Article 5, and shall so inform the Bureau, indicating the final characteristics of the frequency assignment together with the names of the administrations with which agreement has been reached. (WRC-19)

4.2.16<sup>bis</sup> In application of § 4.2.16, an administration may indicate the changes to the information communicated to the Bureau under § 4.2.6 and published under § 4.2.8. In submitting such information, noting the requirements of § 5.1.2, the administration may also request the Bureau to examine the submission in respect of notification under § 5.1.1. (WRC-19)

4.2.17 The agreement of the administrations affected may also be obtained in accordance with this Article, for a specified period. When this specific period of agreement expires for an assignment in the Plan, the assignment in question shall be maintained in the Plan until the end of the period referred to in § 4.2.6 above. After that date this assignment in the Plan shall lapse unless the agreement of the administrations affected is renewed<sup>16ter</sup>. (WRC-19)

4.2.18 When the proposed modification to the Region 2 Plan involves developing countries, administrations shall seek all practicable solutions conducive to the economical development of the broadcasting-satellite systems of these countries.

4.2.19 The Bureau shall publish<sup>17</sup> in a Special Section of its BR IFIC the information<sup>16</sup> received under § 4.2.16 together with the names of any administrations with which the provisions of this Article have been successfully applied. The frequency assignment concerned shall enjoy the same status as those appearing in the Region 2 Plan and will be considered as a frequency assignment in conformity with the Plan. (WRC-03)

4.2.20 When an administration proposing to modify the characteristics of a frequency assignment or to make a new frequency assignment receives notice of disagreement on the part of an administration whose agreement it has sought, it shall first endeavour to solve the problem by exploring all possible means of meeting its requirement. If the problem still cannot be solved by such means, the administration whose agreement has been sought should endeavour to overcome the difficulties as far as possible, and shall state the technical reasons for any disagreement if the administration seeking the agreement requests it to do so. (WRC-19)

---

<sup>16bis</sup> For any remaining affected networks whose assignments were entered in the Plan before the notice received under § 4.2.16, the Bureau shall use the method in Annex 1 to further examine if the remaining corresponding assignments in the Plan are still considered as being affected. The examination in respect of those remaining affected networks is conducted independently using the Appendices 30 and 30A master database corresponding to the Part B Special Section that was published under § 4.2.19. (WRC-19)

<sup>16ter</sup> Unless the Bureau has been informed by the notifying administration of the renewal of the agreement, it shall, no later than six months before the end of the specified period, send a reminder to the notifying administration. (WRC-19)

<sup>17</sup> If the payments are not received in accordance with the provisions of Council Decision 482, as amended, on the implementation of cost recovery for satellite network filings, the Bureau shall cancel the publication, after informing the administration concerned. The Bureau shall inform all administrations of such action and that the network specified in the publication in question no longer has to be taken into consideration by the Bureau and other administrations. The Bureau shall send a reminder to the notifying administration not later than two months prior to the deadline for the payment in accordance with the above-mentioned Council Decision 482 unless the payment has already been received. (WRC-07)



4.2.21 If no agreement is reached between the administrations concerned, the Bureau shall carry out any study that may be requested by these administrations; the Bureau shall inform them of the result of the study and shall make such recommendations as it may be able to offer for the solution of the problem.

4.2.21A If, in spite of the application of § 4.2.20 and 4.2.21, there is still continuing disagreement and the assignment which was the basis of the disagreement is not an assignment in the Region 2 Plan, or in the Regions 1 and 3 Plan or List, or for which the procedure of § 4.1 or 4.2 has been initiated, and if the notifying administration insists that the proposed assignment be included in the Region 2 Plan, the Bureau shall provisionally enter the assignment in the Region 2 Plan with an indication of those administrations whose assignments were the basis of the disagreement; however, the entry shall be changed from provisional to definitive recording in the Region 2 Plan only if the Bureau is informed that the new assignment in the Region 2 Plan has been in use, together with the assignment which was the basis for the disagreement, for at least four months without any complaint of harmful interference being made. (WRC-03)

4.2.21B When requesting the application of § 4.2.21A, the notifying administration shall undertake to meet the requirements of § 4.2.21D and provide to the administration in respect of which § 4.2.21A has been applied, with a copy to the Bureau, a description of the steps by which it undertakes to meet these requirements. (WRC-03)

4.2.21C Should the assignments that were the basis of the disagreement not be brought into use within the period specified in No. **11.44**, the status of the assignment in the Region 2 Plan shall be reviewed accordingly. (WRC-03)

4.2.21D Should harmful interference be caused by an assignment included in the Region 2 Plan under § 4.2.21A to any recorded assignment in the Master Register which was the basis of the disagreement, the administration using the frequency assignment included in the Region 2 Plan under § 4.2.21A shall, upon receipt of advice thereof, immediately eliminate this harmful interference. (WRC-03)

4.2.22 An administration may at any stage in the procedure described, or before applying it, request the assistance of the Bureau.

4.2.23 The relevant provisions of Article 5 shall be applied when frequency assignments are notified to the Bureau.

#### **4.2.24 Cancellation of frequency assignments**

When a frequency assignment in conformity with the Region 2 Plan is no longer required, whether or not as a result of a modification, the administration concerned shall immediately so inform the Bureau. The Bureau shall publish this information in a Special Section of its BR IFIC and delete the assignment from the Region 2 Plan.

#### **4.2.25 Master copy of the Region 2 Plan**

4.2.25.1 The Bureau shall maintain an up-to-date master copy of the Region 2 Plan, including the overall equivalent protection margins of each assignment, taking account of the application of the procedure set out in this Article. This master copy shall contain the overall equivalent protection margins derived from the Plan as established by the 1983 Conference and those derived from all modifications to the Plan as a result of the successful completion of the modification procedure set out in this Article.

4.2.25.2 An up-to-date version of the Region 2 Plan shall be published by the Secretary-General when justified by the circumstances.

## ARTICLE 5 (REV.WRC-19)

**Notification, examination and recording in the Master International  
Frequency Register of frequency assignments to space stations  
in the broadcasting-satellite service<sup>18</sup> (WRC-07)**

**5.1 Notification**

5.1.1 Whenever an administration<sup>19</sup> intends to bring into use a frequency assignment to a space station in the broadcasting-satellite service, it shall notify this frequency assignment to the Bureau. For this purpose, the notifying administration shall apply the following provisions. (WRC-03)

5.1.2 For any notification under § 5.1.1, an individual notice for each frequency assignment shall be drawn up as prescribed in Appendix 4, the various Sections of which specify the basic characteristics to be provided as appropriate. It is recommended that the notifying administration should also supply any other data it may consider useful. (WRC-2000)

5.1.2*bis* In application of § 5.1.2, an administration may identify the characteristics of assignments in the Plans or the List as notification and send to the Bureau the changes thereto. (WRC-03)

5.1.3 Each notice must reach the Bureau not earlier than three years before the date on which the frequency assignment is to be brought into use. In any case, the notice must reach the Bureau not later than three months before that date<sup>20</sup>. (WRC-19)

5.1.4 Any frequency assignment the notice of which reaches the Bureau after the applicable period specified in § 5.1.3 shall, where it is to be recorded, bear a remark in the Master Register to indicate that it is not in conformity with § 5.1.3.

5.1.5 Any notice made under § 5.1.1 which does not contain the characteristics specified in Appendix 4 shall be returned by the Bureau immediately by airmail to the notifying administration with the relevant reasons. (WRC-2000)

---

<sup>18</sup> If the payments are not received in accordance with the provisions of Council Decision 482, as amended, on the implementation of cost recovery for satellite network filings, the Bureau shall cancel the publication specified in § 5.1.6 and the corresponding entries in the Master Register under § 5.2.2, 5.2.2.1, 5.2.2.2 or 5.2.6, as appropriate, and the corresponding entries included in the Plan on and after 3 June 2000 or in the List, as appropriate, after informing the administration concerned. The Bureau shall inform all administrations of such action. The Bureau shall send a reminder to the notifying administration not later than two months prior to the deadline for the payment in accordance with the above-mentioned Council Decision 482 unless the payment has already been received. See also Resolution **905 (WRC-07)\***. (WRC-07)

\* *Note by the Secretariat:* This Resolution was abrogated by WRC-12.

<sup>19</sup> A frequency assignment may be notified by one administration acting on behalf of a group of named administrations. Any further notice (modification or deletion) relating to that assignment shall, in the absence of information to the contrary, be regarded as having been submitted on behalf of the entire group. (WRC-03)

<sup>20</sup> Where appropriate, the notifying administration shall initiate the procedure for modifying the Plan concerned or for including assignments in the Regions 1 and 3 List in sufficient time to ensure that this limit is observed. For Region 2, see also Resolution **42 (Rev.WRC-19)** and § B of Annex 7. (WRC-19)

5.1.6 Upon receipt of a complete notice, the Bureau shall include its particulars, with the date of receipt, in its BR IFIC, which shall contain the particulars of all such notices received since the publication of the previous Circular. (WRC-2000)

5.1.7 The Circular shall constitute the acknowledgement to the notifying administration of the receipt of a complete notice.

5.1.8 Complete notices shall be considered by the Bureau in order of receipt. The Bureau shall not postpone its finding unless it lacks sufficient data to reach a decision; moreover, the Bureau shall not act upon any notice which has a technical bearing on an earlier notice still under consideration by the Bureau until it has reached a finding with respect to such earlier notice.

## 5.2 Examination and recording

### 5.2.1 The Bureau shall examine each notice:

- a) with respect to its conformity with the Constitution, the Convention and the relevant provisions of the Radio Regulations (with the exception of those relating to § *b*), *c*), *d*) and *e*) below);
- b) with respect to its conformity with the appropriate Regional Plan or the Regions 1 and 3 List, as appropriate; *or*
- c) with respect to the coordination requirements specified in the Remarks column of Article 10 or Article 11; *or*
- d) with respect to its conformity with the appropriate Regional Plan or the Regions 1 and 3 List, however, having characteristics differing from those in the appropriate Regional Plan or in the Regions 1 and 3 List, in one or more of the following aspects:
  - use of a reduced e.i.r.p.,
  - use of a reduced coverage area entirely situated within the coverage area appearing in the appropriate Regional Plan or in the Regions 1 and 3 List,
  - use of other modulating signals in accordance with the provisions of § 3.1.3 of Annex 5,
  - use of the assignment for transmission in the fixed-satellite service in accordance with No. 5.492,
  - in the case of Region 2, use of an orbital position under the conditions specified in § B of Annex 7,
  - in the case of the notification of Plan assignments, use of an e.i.r.p. which produces a pfd that exceeds the limit of  $-103.6 \text{ dB(W/(m}^2 \cdot 27 \text{ MHz))}$  given in Section 1 of Annex 1 to Appendix 30 on the territory of the notifying administration under the condition that the calculated pfd at test points of any Plan assignment, List assignment or proposed assignment submitted under Article 4 are equal to or below that of the original Plan assignments in the same channel of the administration applying this section; *or*
- e) with respect to its conformity with the provisions of Resolution 42 (Rev.WRC-19). (WRC-19)

5.2.2 Where the Bureau reaches a favourable finding with respect to § 5.2.1 *a*), 5.2.1 *b*) and 5.2.1 *c*), the frequency assignment of an administration shall be recorded in the Master Register. The date of receipt of the notice by the Bureau shall be entered in the Master Register. In relations between administrations, all frequency assignments brought into use in conformity with the appropriate Regional Plan and recorded in the Master Register shall be considered to have the same status irrespective of the dates of receipt entered in the Master Register for such frequency assignments. (WRC-07)

5.2.2.1 Where the Bureau reaches a favourable finding with respect to § 5.2.1 *a*), 5.2.1 *c*) and 5.2.1 *d*), the frequency assignment shall be recorded in the Master Register. The date of receipt of the notice by the Bureau shall be entered in the Master Register. In relations between administrations, all frequency assignments brought into use in conformity with the appropriate Regional Plan and recorded in the Master Register shall be considered to have the same status irrespective of the dates of receipt entered in the Master Register for such frequency assignments. When recording these assignments, the Bureau shall indicate by an appropriate symbol the characteristics having a value different from that appearing in the appropriate regional Plan. (WRC-07)

5.2.2.2 In the case of Region 2, where the Bureau reaches a favourable finding with respect to § 5.2.1 *a*) and 5.2.1 *c*), but an unfavourable finding with respect to § 5.2.1 *b*) and 5.2.1 *d*), it shall examine the notice with respect to the successful application of the provisions of Resolution 42 (Rev.WRC-19). A frequency assignment for which the provisions of Resolution 42 (Rev.WRC-19) have been successfully applied shall be recorded in the Master Register with an appropriate symbol to indicate its interim status. The date of receipt of the notice by the Bureau shall be entered in the Master Register. In relations between administrations all frequency assignments brought into use following the successful application of the provisions of Resolution 42 (Rev.WRC-19) and recorded in the Master Register shall be considered to have the same status irrespective of the dates of receipt entered in the Master Register for such frequency assignments. (WRC-19)

5.2.2.3 In the case of Regions 1 and 3, when the Bureau reaches a favourable finding with respect to § 5.2.1 *a*) and 5.2.1 *c*) but an unfavourable finding with respect to § 5.2.1 *b*) and 5.2.1 *d*), the notice shall be returned immediately by airmail to the notifying administration with the Bureau's reasons for this finding and with such suggestions as the Bureau may be able to offer with a view to a satisfactory solution of the problem. (WRC-2000)

5.2.3 Whenever a frequency assignment is recorded in the Master Register, the finding reached by the Bureau shall be indicated. (WRC-07)

5.2.4 Where the Bureau reaches an unfavourable finding with respect to:

- § 5.2.1 *a*), or
- § 5.2.1 *c*), or
- § 5.2.1 *b*) and 5.2.1 *d*) and, where applicable, § 5.2.1 *e*),

the notice shall be returned immediately by airmail to the notifying administration with the reasons of the Bureau for this finding and with such suggestions as the Bureau may be able to offer with a view to a satisfactory solution of the problem. (WRC-2000)

5.2.5 Where the notifying administration resubmits the notice and the finding of the Bureau becomes favourable with respect to the appropriate parts of § 5.2.1, the notice shall be treated as in § 5.2.2, 5.2.2.1 or 5.2.2.2, as appropriate.

5.2.6 If the notifying administration resubmits the notice without modification and insists on its reconsideration, and if the Bureau's finding with respect to § 5.2.1 remains unfavourable, the notice is returned to the notifying administration in accordance with § 5.2.4. In this case, the notifying administration undertakes not to bring into use the frequency assignment until the condition specified in § 5.2.5 is fulfilled. For Regions 1, 2 and 3, in the event that the Bureau has been informed of agreement to modification of the Plan for a specified period of time in accordance with Article 4, the frequency assignment shall be recorded in the Master Register with a note indicating that the frequency assignment is valid only for the period specified. The notifying administration using the frequency assignment over a specified period shall not subsequently invoke this fact to justify the continued use of the frequency beyond the period specified unless it obtains the agreement of the administration(s) concerned.

5.2.7 If a frequency assignment notified in advance of bringing into use in conformity with § 5.1.3 has received a favourable finding by the Bureau with respect to the provisions of § 5.2.1, it shall be entered provisionally in the Master Register with a special symbol in the Remarks Column indicating the provisional nature of that entry.

5.2.8 When the Bureau has received confirmation that the frequency assignment has been brought into use, the Bureau shall remove the symbol in the Master Register.

5.2.9 The date of bringing into use notified by the administration concerned shall be recorded in the Master Register. (WRC-07)

5.2.10 Wherever the use of a frequency assignment to a space station recorded in the Master Register and emanating from the Regions 1 and 3 List is suspended for a period exceeding six months, the notifying administration shall inform the Bureau of the date on which such use was suspended. When the recorded assignment is brought back into use, the notifying administration shall so inform the Bureau, as soon as possible. On receipt of the information sent under this provision, the Bureau shall make that information available on the ITU website as soon as possible and shall publish it in the BR IFIC. The date on which the recorded assignment is brought back into use<sup>20bis</sup> shall be no later than three years from the date on which the use of the frequency assignment was suspended, provided that the notifying administration informs the Bureau of the suspension within six months from the date on which the use was suspended. If the notifying administration informs the Bureau of the suspension more than six months after the date on which the use of the frequency assignment was suspended, this three-year time period shall be reduced. In this case, the amount by which the three-year period shall be reduced shall be equal to the amount of time that has elapsed between the end of the six-month period and the date that the Bureau is informed of the suspension. If the notifying administration informs the Bureau of the suspension more than 21 months after the date on which the use of the frequency assignment was suspended, the frequency assignment shall be cancelled. (WRC-19)

---

<sup>20bis</sup> The date of bringing back into use of a frequency assignment to a space station in the geostationary-satellite orbit shall be the commencement of the 90-day period defined below. A frequency assignment to a space station in the geostationary-satellite orbit shall be considered as having been brought back into use when a space station in the geostationary-satellite orbit with the capability of transmitting or receiving that frequency assignment has been deployed and maintained at the notified orbital position for a continuous period of 90 days. The notifying administration shall inform the Bureau within 30 days from the end of the 90-day period. Resolution 40 (Rev.WRC-19) shall apply. (WRC-19)

5.2.11 If a recorded frequency assignment stemming from the Regions 1 and 3 List is not brought back into use within the suspension period resulting from the application of § 5.2.10 above, the Bureau shall cancel the assignment from the Master Register and the assignment in the List, unless the assignment is one to which § 4.1.26 or § 4.1.27 is being applied. (WRC-15)

### 5.3 Cancellation of entries in the Master Register

5.3.1 Any notified frequency assignment to which the Article 4 procedures have been applied and which has been provisionally recorded under § 5.2.7 shall be brought into use no later than the end of the period provided under § 4.1.3, 4.1.3*bis*, 4.2.6 or 4.2.6*bis* of Article 4. Any other frequency assignment provisionally recorded under § 5.2.7 shall be brought into use by the date specified in the notice. Unless the Bureau has been informed by the notifying administration of the bringing into use of the assignment under § 5.2.8, it shall, no later than 15 days before the notified date of bringing into use or the end of the regulatory period established under § 4.1.3, 4.1.3*bis*, 4.2.6 or 4.2.6*bis* of Article 4, as appropriate, send a reminder requesting confirmation that the assignment has been brought into use within the regulatory period. If the Bureau does not receive that confirmation within 30 days following the notified date of bringing into use or the period provided under § 4.1.3, 4.1.3*bis*, 4.2.6 or 4.2.6*bis* of Article 4, as the case may be, it shall cancel the entry in the Master Register. (WRC-15)

5.3.2 If the use of any recorded frequency assignment is permanently discontinued, the notifying administration shall so inform the Bureau within three months, whereupon the entry shall be removed from the Master Register.

## ARTICLE 6 (WRC-2000)

### **Coordination, notification and recording in the Master International Frequency Register of frequency assignments to terrestrial stations or to earth stations in the fixed-satellite service (Earth-to-space) affecting frequency assignments to broadcasting-satellite stations in the bands 11.7-12.2 GHz (in Region 3), 11.7-12.5 GHz (in Region 1) and 12.2-12.7 GHz (in Region 2)<sup>21</sup>**

6.1 The provisions of No. 9.19 and the associated provisions under Articles 9 and 11 are applicable in respect of frequency assignments to broadcasting-satellite stations in the bands 11.7-12.5 GHz in Region 1, 12.2-12.7 GHz in Region 2 and 11.7-12.2 GHz in Region 3:

- a) to transmitting terrestrial stations in the band 11.7-12.7 GHz in all Regions;
- b) to transmitting earth stations in the fixed-satellite service in the band 12.5-12.7 GHz (in Region 1).

---

<sup>21</sup> These procedures do not replace the procedures prescribed for terrestrial stations in Articles 9 and 11.

6.2 In applying the procedures referred to in § 6.1, the provisions of Appendix 5 are replaced by the following:

6.2.1 These procedures are to be applied in respect of administrations whose territory is included within the service area associated with:

- a) assignments in conformity with the appropriate Regional Plan in Appendix 30;
- b) assignments included in the Regions 1 and 3 List;
- c) assignments for which the procedure of Article 4 has been initiated, as from the date of receipt of the complete Appendix 4 information under § 4.1 or 4.2.

6.2.2 The criteria to be applied are those given in Annex 3.

ARTICLE 7 (REV.WRC-19)

**Coordination, notification and recording in the Master International Frequency Register of frequency assignments to stations in the fixed-satellite service (space-to-Earth) in the bands 11.7-12.2 GHz (in Region 2), 12.2-12.7 GHz (in Region 3) and 12.5-12.7 GHz (in Region 1), and to stations in the broadcasting-satellite service in the band 12.5-12.7 GHz (in Region 3) when frequency assignments to broadcasting-satellite stations in the bands 11.7-12.5 GHz in Region 1, 12.2-12.7 GHz in Region 2 and 11.7-12.2 GHz in Region 3 are involved<sup>22</sup>**

7.1 The provisions of No. 9.7 and the associated provisions under Articles 9 and 11 are applicable in respect of frequency assignments to broadcasting-satellite stations in the frequency bands 11.7-12.5 GHz in Region 1, 12.2-12.7 GHz in Region 2 and 11.7-12.2 GHz in Region 3:

- a) to transmitting space stations in the fixed-satellite service in the frequency bands 11.7-12.2 GHz (in Region 2), 12.2-12.7 GHz (in Region 3) and 12.5-12.7 GHz (in Region 1); and
- b) to transmitting space stations in the broadcasting-satellite service in the frequency band 12.5-12.7 GHz (in Region 3). (WRC-19)

7.2 In applying the procedures referred to in § 7.1, the provisions of Appendix 5 are replaced by the following:

---

<sup>22</sup> These provisions do not replace the procedures prescribed in Articles 9 and 11 when stations other than those in the broadcasting-satellite service subject to a Plan are involved. (WRC-03)

<sup>23</sup> (SUP – WRC-19)

- 7.2.1 The frequency assignments to be taken into account are:
- a) the assignments in conformity with the appropriate Regional Plan in Appendix 30;
  - b) the assignments included in the Regions 1 and 3 List;
  - c) the assignments for which the procedure of Article 4 has been initiated, as from the date of receipt of the complete Appendix 4 information under § 4.1.3 or 4.2.6. (WRC-03)
- 7.2.2 The criteria to be applied are those given in Annex 4.

## ARTICLE 8

### **Miscellaneous provisions relating to the procedures\***

8.1 If so requested by any administration, the Board, using such means at its disposal as are appropriate in the circumstances, shall conduct a study of cases of alleged contravention or non-observance of these provisions or of harmful interference.

8.2 The Board shall thereupon prepare and forward to the administration or administrations concerned a report containing its findings and recommendations for the solution of the problem.

8.3 On receiving the Board's recommendations for the solution of the problem, an administration shall promptly acknowledge their receipt by telegram and shall indicate the action it intends to take. Where the Board's suggestions or recommendations are unacceptable to the administrations concerned, further efforts should be made by the Board to find an acceptable solution to the problem.

8.4 Where, as a result of a study, the Board submits to one or more administrations suggestions or recommendations for the solution of a problem, and where no reply has been received from one or more of these administrations within a period of three months, the Board shall consider that the suggestions or recommendations concerned are unacceptable to the administrations which did not answer. If it was the requesting administration which failed to answer within this period, the Board shall discontinue the study.

8.5 If so requested by any administration, particularly by an administration of a country in need of special assistance, the Board, using such means at its disposal as are appropriate in the circumstances, shall render the following assistance:

- a) computation necessary in the application of Annexes 1, 3 and 4;
- b) any other assistance of a technical nature for completion of the procedures in this Appendix.

8.6 In making a request to the Board under § 8.5, the administration shall provide the Board with the necessary information.

---

\* *Note by the Secretariat:* WRC-97 did not review this Article. The subject matter is also dealt with in Articles 13 and 14, which were reviewed by WRC-97.



ARTICLE 9 (SUP - WRC-03)

ARTICLE 10 (REV.WRC-19)

**The Plan for the broadcasting-satellite service in the frequency band 12.2-12.7 GHz in Region 2**

10.1 COLUMN HEADINGS OF THE PLAN

- Col. 1 *Beam identification* (Column 1 contains the symbol designating the country or the geographical area taken from Table B1 of the Preface to the International Frequency Information Circular (BR IFIC) followed by the symbol designating the service area).
- Col. 2 *Nominal orbital position*, in degrees and hundredths of a degree.
- Col. 3 *Channel number* (see Table 4 showing channel numbers and corresponding assigned frequencies).
- Col. 4 *Boresight* geographical coordinates, in degrees and hundredths of a degree.
- Col. 5 *Antenna beamwidth*. This column contains two figures corresponding to the major axis and the minor axis respectively of the elliptical cross-section half-power beam, in degrees and hundredths of a degree.
- Col. 6 *Orientation of the ellipse* determined as follows: in a plane normal to the beam axis, the direction of a major axis of the ellipse is specified as the angle measured anti-clockwise from a line parallel to the equatorial plane to the major axis of the ellipse to the nearest degree.
- Col. 7 *Polarization* (1 = direct, 2 = indirect)<sup>24</sup>.
- Col. 8 *e.i.r.p.* in the direction of maximum radiation, in dBW.
- Col. 9 *Remarks*.

10.2 TEXT FOR NOTES IN REMARKS COLUMN OF THE PLAN

- 1 Fast roll-off space station transmitting antenna as defined in Annex 5 (item 3.13.3).
- 2 Television standard with 625 lines using greater video bandwidth and necessary bandwidth of 27 MHz.
- 3 Not used

---

<sup>24</sup> See Annex 5 (§ 3.2) of this Appendix.

4 This assignment may be utilized in the geographical area of Anguilla (AIA) (which is in the beam area).

5 Feeder-link earth stations for this assignment may also be located in the territories of Puerto Rico and the United States Virgin Islands. Such operation shall not cause more interference nor require more protection than the assignment under the Plan.

6 Feeder-link earth stations for this assignment may also be located in the States of Alaska and Hawaii. Such operation shall not cause more interference nor require more protection than the assignment under the Plan.

7 The feeder-link earth station for this assignment may also be located at the point with geographical coordinates 3° 31' West, 48° 46' North. Such operation shall not cause more interference nor require more protection than the assignment under the Plan.

8 Feeder-link earth stations for this assignment may also be located at the points with the following geographical coordinates:

47° 55' West	15° 47' South	34° 53' West	08° 04' South
43° 13' West	22° 55' South	60° 02' West	03° 06' South
46° 38' West	23° 33' South	38° 31' West	12° 56' South
51° 13' West	30° 02' South	49° 15' West	16° 40' South

Such operation shall not cause more interference nor require more protection than the assignment under the Plan.

9/GR . . . This assignment is part of a group, the number of which follows the symbol. The group consists of the beams and has the number of channels assigned to it as indicated in Table 1 below.

a) The overall equivalent protection margin to be used for the application of Article 4 and Resolution 42 (Rev. WRC-19) shall be calculated on the following basis:

- for the calculation of interference to assignments that are part of a group, only the interference contributions from assignments that are not part of the same group are to be included; and
- for the calculation of interference from assignments belonging to a group to assignments that are not part of that same group, only the worst interference contribution from that group shall be used on a test point to test point basis. (WRC-03)

b) If an administration notifies the same frequency in more than one beam of a group for use at the same time, the aggregated *C/I* produced by all emissions from that group shall not exceed the *C/I* calculated on the basis of a) above.

10 This assignment shall be brought into use only when the limits given in Table 2 are not exceeded or with the agreement of the affected administration identified in Table 3.

These administrations shall be informed by the notifying administration of changes in characteristics before these beams are brought into use.

TABLE 1

Group	Beams in the group	Number of channels assigned to the group
GR1	ALS00002 HWA00002 USAPSA02	32 channels
GR2	ALS00003 HWA00003 USAPSA03	32 channels
GR3	ARGINSU4 ARGSUR04	16 channels
GR4	ARGINSU5 ARGSUR05	12 channels
GR5	BOLAND01 CLMAND01 EQACAND1 EQAGAND1 PRUAND02 VENAND03	16 channels
GR6	B SU111 B SU211	32 channels
GR7	B CE311 B CE411 B CE511	32 channels
GR8	B NO611 B NO711 B NO811	32 channels
GR9	B SU112 B SU212 B CE312 B CE412	32 channels
GR10	CAN01101 CAN01201	32 channels
GR11	<i>Not used</i>	
GR12	CAN01203 CAN01303 CAN01403	32 channels
GR13	CAN01304 CAN01404 CAN01504	32 channels
GR14	CAN01405 CAN01505 CAN01605	32 channels
GR15	<i>Not used</i>	
GR16	CHLCONT4 CHLCONT6	16 channels
GR17	CHLCONT5 PAQPAC01 CHLPAC02	16 channels
GR18	CRBBER01 CRBBLZ01 CRBJMC01 CRBBAH01 CRBECO01	16 channels
GR19	EQACOO01 EQAGOO01	16 channels
GR20	PTRVIR01 USAEHO02	32 channels
GR21	PTRVIR02 USAEHO03	32 channels
GR22	VEN02VEN VEN11VEN	4 channels

TABLE 2

**Applicable criteria**

Symbol	pfd limit criteria
a	§ 3, Annex 1
b	§ 5 b), Annex 1
c	§ 5 c), Annex 1
d	§ 5 d), Annex 1

Note – Section 5 of Annex 1 was merged with Section 4 by WRC-2000. See also the Note to Table 3. (WRC-2000)

11 This assignment shall be brought into use only when the e.i.r.p. in the direction of all points situated within the service area and within the -3 dB contour of the “Metropole” beam (space-to-Earth) in the VIDEOSAT-3 network as described in ex-IFRB Special Section AR11/C/766 to BR IFIC No. 1678 of 2 July 1985 does not exceed the limit 26.8 dBW.

12 This assignment shall be brought into use only when the e.i.r.p. in the direction of all points situated within the service area and within the  $-3$  dB contour of the “Metropole” beam (space-to-Earth) in the VIDEOSAT-3 network as described in ex-IFRB Special Section AR11/C/766 to Weekly Circular No. 1678 of 2 July 1985 does not exceed the limit 26.8 dBW, and when the e.i.r.p. in the direction of all points situated within the service area and also between the  $-3$  dB and  $-6$  dB contours of the same beam does not exceed the limit 29.5 dBW.

TABLE 3

Beam name	Channels	Limit criteria ref. Table 2	Countries or geographical areas affected*
ALS00002	1, 4, 5, 6, 9, 10, 11, 14, 15, 16 All channels For channels 20 to 32	a c d	URS MNG/URS URS
ALS00003	1, 4, 5, 6, 9, 10, 11, 14, 15, 16 All channels For channels 20 to 32	a c d	URS URS URS
ARGINSU5	3, 7, 11, 15, 17, 19	b	NOR
ARGNORT4	2, 4, 6, 8, 10, 12, 14, 16, 18, 20	b	AOE/ASC/AZR/CPV/E/GMB/GNB/GUI/MRC/MTN/POR/SEN
ARGNORT5	2, 4, 6, 8, 10, 12, 14, 16, 18, 20	b	AFS/AGL/BOT/NMB/NOR/OCE/PTC/TKL/COD/ZMB/ZWE
ARGSUR04	1, 3, 5, 7, 9, 11, 13, 15, 17, 19	b	ASC
ARGSUR05	3, 7, 11, 15, 17, 19	b	NOR
B CE311	For channels 1 to 20	b	AGL/ALG/CAF/CME/COG/GAB/GNE/NGR/NIG/NMB/STP/TCD/COD
B CE312	For channels 1 to 20  For channels 1 to 20 All channels	b c c	AFS/BDI/BOT/LSO/RRW/TZA/UGA/ZMB/ZWE MOZ/MWI/TZA ETH/KEN/SDN
B CE411	For channels 1 to 20	b	AGL/ALG/CAF/CME/COG/CVA/E/GAB/GNE/I/LBY/MLT/NGR/NIG/SMR/STP/TCD/TUN/COD
B CE412	For channels 1 to 20 All channels	c c	CYP/TUR ARS/EGY/ISR/SDN/URS
B CE511	For channels 1 to 20	b	CAF/CME/COG/GAB/GNE/NIG/NMB/NOR/STP/COD
B NO611	For channels 1 to 20	b	BEN/GHA/TGO
B NO711	For channels 1 to 20	b	BEN
B SE911	2, 4, 6, 8, 10, 12, 14, 16, 18, 20	b	CPV

\* *Note by the Secretariat:* This Table was not modified by WRC-97. As such, the references to ETH, TCH, URS and YUG in this column refer to the countries or geographical areas described by these symbols when the Plan was established.

TABLE 3 (continued)

Beam name	Channels	Limit criteria ref. Table 2	Countries or geographical areas affected*
B SU111	For channels 1 to 20	b	BFA/CTI/GHA/GUI/LBR/MTN/SHN/TRC
B SU211	For channels 1 to 20	b	ALG/BFA/CTI/GHA/GUI/LBR/MLI/MRC/MTN/SHN/TRC
BERBER02	1, 5, 17 5, 9, 13	a a	CNR/E ISL
BOL00001	3, 7, 11, 15, 19	b	ALG/AOE/ASC/E/GMB/GNB/GUI/LBR/MLI/MRC/MTN/POR/SEN/SRL/TRC
CAN01101	All channels For channels 20 to 32	c d	URS URS
CAN01201	All channels	c	URS
CAN01203	All channels	c	URS
CAN01303	All channels	c	URS
CAN01403	All channels	c	URS
CAN01404	For channels 1 to 20	b	ISL/POR
CAN01405	For channels 1 to 20	b	F/G/IRL/ISL
CAN01504	For channels 1 to 20	b	AOE/AZR/E/ISL/MRC/MTN/POR
CAN01505	For channels 1 to 20	b	ALG/E/F/G/IRL/ISL/MRC/POR
CAN01605	For channels 1 to 20	b	E/F/G/IRL/ISL/MRC/POR
CAN01606	For channels 1 to 20	b	BEL/F/G/HOL/IRL/ISL/LUX/NOR
CLMAND01	21, 23, 25, 27, 29, 31	c	URS
CLM00001	1, 3, 5, 7, 9, 11, 13, 15, 17, 19 21, 23, 25, 27, 29, 31	b c	AZR/CPV URS
CRBEC001	2, 4, 6, 8, 10, 12, 14, 16, 18, 20	b	ASC/AZR/GMB/GNB/GUI/ISL/MTN/SEN/SRL
FLKANT01	1, 5, 9, 13	b	NOR
GRLDNK01	3, 7, 11, 15, 19	b	D/DNK/G/HOL/ISL/NOR/POL/S/TCH
GUFMGG02	4, 8, 12, 16, 20	b	NOR
HWA00002	For channels 1 to 20 All channels	b c	CHN/KRE MNG/URS
HWA00003	For channels 1 to 20 All channels	b c	CHN MNG/URS
MEX02NTE	All channels	c	URS
MEX01SUR	1, 3, 5, 7, 9, 11, 13, 15, 17, 19	b	KIR

TABLE 3 (end)

Beam name	Channels	Limit criteria ref. Table 2	Countries or geographical areas affected*
MEX02SUR	All channels	c	URS
PRU00004	2, 4, 6, 8, 10, 12, 14, 16, 18, 20	b	ALG/AOE/ASC/BFA/CTI/E/G/GMB/GUI/ISL/LBR/MLI/MRC/MTN/POR/SEN/SHN/SRL/TRC
SPMFRAN3	1, 5, 9, 13, 17	b	D/DNK/ISL/NOR/S
USAEH001	For channels 1 to 20	b	ALG/AUT/BEL/CVA/D/DNK/E/F/G/HOL/I/ISL/LBY/LIE/LUX/MCO/MLT/NGR/NIG/NOR/OCE/SMR/SUI/TCH/TUN/YUG
USAEH002	For channels 1 to 20 All channels	b c	AZR/CPV/HWL URS
USAEH003	For channels 1 to 20 All channels	b c	MHL URS
USAEH004	For channels 1 to 20 All channels For channels 20 to 32	b c d	WAK URS URS
USAWH101	All channels	c	URS
USAWH102	All channels	c	URS
VENAND03	21, 23, 25, 27, 29, 31	c	URS
VEN11VEN	2, 4, 6, 8, 10, 12, 14, 16, 18, 20 20, 22, 24, 26, 28, 30, 32	b c	AZR/CPV URS

Note – The administrations listed in Table 3 were identified on the basis of the criteria adopted at the Regional Administrative Conference for the Planning of the Broadcasting-satellite Service in Region 2 (Geneva, 1983) (RARC Sat-R2), as shown in Table 2. WRC-2000 and WRC-03 revised the criteria applicable to determine affected administrations. Therefore, the Bureau, when receiving a notification for an assignment in the Region 2 Plan, shall determine which countries are affected on the basis of the revised criteria adopted by WRC-03, which may lead to a different set of affected administration(s) from that currently contained in Table 3. (WRC-07)

### Country symbols

1 For the explanation of symbols designating countries or geographical areas in Region 2, see the Preface to the BR IFIC.

2 One additional symbol, CRB, has been created for the purposes of the 1983 Conference only, to designate to geographical area in the Caribbean Area. The five Caribbean beams are identified as follows:

CRBBAH01, CRBBER01, CRBBLZ01, CRBEC001 and CRBJMC01

and are intended collectively to provide coverage for the following countries or geographical areas: AIA, ATG, BAH, BER, BLZ, BRB, CYM, DMA, GRD, GUY, JMC, LCA, MSR, KNA, SUR, TCA, TRD, VCT and VRG to be so used if approved by them.

TABLE 4

Table showing correspondence between channel numbers and assigned frequencies

Channel No.	Assigned frequency (MHz)	Channel No.	Assigned frequency (MHz)
1	12 224.00	17	12 457.28
2	12 238.58	18	12 471.86
3	12 253.16	19	12 486.44
4	12 267.74	20	12 501.02
5	12 282.32	21	12 515.60
6	12 296.90	22	12 530.18
7	12 311.48	23	12 544.76
8	12 326.06	24	12 559.34
9	12 340.64	25	12 573.92
10	12 355.22	26	12 588.50
11	12 369.80	27	12 603.08
12	12 384.38	28	12 617.66
13	12 398.96	29	12 632.24
14	12 413.54	30	12 646.82
15	12 428.12	31	12 661.40
16	12 442.70	32	12 675.98

## 12 224.00 MHz (1)

1	2	3	4		5		6	7	8	9	
ALS00002	-166.20	1	-149.66	58.37	3.76	1.24	170	1	59.7	9/GR1	10
ALS00003	-175.20	1	-150.98	58.53	3.77	1.11	167	1	60.0	9/GR2	10
ARGINSU4	-94.20	1	-52.98	-59.81	3.40	0.80	19	1	59.9	9/GR3	
ARGSU04	-94.20	1	-65.04	-43.33	3.32	1.50	40	1	60.7	9/GR3	10
B CE311	-64.20	1	-40.60	-6.07	3.04	2.06	174	1	61.6	8 9/GR7	10
B CE312	-45.20	1	-40.27	-6.06	3.44	2.09	174	1	61.0	8 9/GR9	10
B CE411	-64.20	1	-50.97	-15.27	3.86	1.38	49	1	62.6	8 9/GR7	10
B CE412	-45.20	1	-50.71	-15.30	3.57	1.56	52	1	62.7	8 9/GR9	10
B CE511	-64.20	1	-53.10	-2.90	2.44	2.13	104	1	63.0	8 9/GR7	10
B NO611	-74.20	1	-59.60	-11.62	2.85	1.69	165	2	62.8	8 9/GR8	10
B NO711	-74.20	1	-60.70	-1.78	3.54	1.78	126	2	62.8	8 9/GR8	10
B NO811	-74.20	1	-68.76	-4.71	2.37	1.65	73	2	62.8	8 9/GR8	10
B SU111	-81.20	1	-51.12	-25.63	2.76	1.05	50	1	62.8	8 9/GR6	10
B SU112	-45.20	1	-50.75	-25.62	2.47	1.48	56	1	62.2	8 9/GR9	
B SU11	-81.20	1	-44.51	-16.95	3.22	1.36	60	1	62.5	8 9/GR6	10
B SU212	-45.20	1	-44.00	-16.87	3.20	1.96	58	1	61.3	8 9/GR9	
BAHIFRB1	-87.20	1	-76.06	24.16	1.81	0.80	142	1	61.6		
BERBERMU	-96.20	1	-64.77	32.32	0.80	0.80	90	2	56.8		
BERBERO2	-31.00	1	-64.77	32.32	0.80	0.80	90	1	56.9	2	10
BOLAND01	-115.20	1	-65.04	-16.76	2.49	1.27	76	1	67.9	9/GR5	
CAN01101	-138.20	1	-125.63	57.24	3.45	1.27	157	1	59.5	9/GR10	10
CAN01201	-138.20	1	-112.04	55.95	3.35	0.97	151	1	59.6	9/GR10	10
CAN01202	-72.70	1	-107.70	55.63	2.74	1.12	32	1	59.6		
CAN01203	-129.20	1	-111.48	55.61	3.08	1.15	151	1	59.5	9/GR12	10
CAN01303	-129.20	1	-102.42	57.12	3.54	0.91	154	1	60.0	9/GR12	10
CAN01304	-91.20	1	-99.12	57.36	1.98	1.72	2	1	59.8	9/GR13	
CAN01403	-129.20	1	-89.75	52.02	4.68	0.80	148	1	61.8	9/GR12	10
CAN01404	-91.20	1	-84.82	52.42	3.10	2.05	152	1	60.4	9/GR13	10
CAN01405	-82.20	1	-84.00	52.39	2.84	2.29	172	1	60.3	9/GR14	10
CAN01504	-91.20	1	-72.66	53.77	3.57	1.67	156	1	60.2	9/GR13	10
CAN01505	-82.20	1	-71.77	53.79	3.30	1.89	162	1	60.1	9/GR14	10
CAN01605	-82.20	1	-61.50	49.55	2.65	1.40	143	1	60.3	9/GR14	10
CAN01606	-70.70	1	-61.30	49.55	2.40	1.65	148	1	60.2	10	
CHLCONT5	-106.20	1	-72.23	-35.57	2.60	0.80	55	1	59.4	9/GR17	
CHLPAC02	-106.20	1	-80.06	-30.06	1.36	0.80	69	1	59.2	9/GR17	
CLMAND01	-115.20	1	-74.72	5.93	3.85	1.63	114	1	64.9	9/GR5	
CLM00001	-103.20	1	-74.50	5.87	3.98	1.96	118	1	63.5	10	
EQACAND1	-115.20	1	-78.40	-1.61	1.37	0.95	75	1	64.0	9/GR5	
EQAGAND1	-115.20	1	-90.34	-0.62	0.90	0.81	89	1	61.3	9/GR5	
FLKANT01	-57.20	1	-44.54	-60.13	3.54	0.80	12	1	59.3	2	10
FLKFALKS	-31.00	1	-59.90	-51.64	0.80	0.80	90	1	58.1	2	
GRD00002	-42.20	1	-61.58	12.29	0.80	0.80	90	1	58.8		
HWA00002	-166.20	1	-165.79	23.42	4.20	0.80	160	1	58.8	9/GR1	10
HWA00003	-175.20	1	-166.10	23.42	4.25	0.80	159	1	58.8	9/GR2	10
MEX01NTE	-78.20	1	-105.81	26.01	2.89	2.08	155	1	60.5	1	
MEX01SUR	-69.20	1	-94.84	19.82	3.05	2.09	4	1	62.2	1	10
MEX02NTE	-136.20	1	-107.21	26.31	3.84	1.55	148	1	61.2	1	10
MEX02SUR	-127.20	1	-96.39	19.88	3.18	1.87	157	1	62.5	1	10
PAQPAC01	-106.20	1	-109.18	-27.53	0.80	0.80	90	1	56.2	9/GR17	
PRG00002	-99.20	1	-58.66	-23.32	1.45	1.04	76	1	60.2		
PRUAND02	-115.20	1	-74.69	-8.39	3.41	1.79	95	1	63.9	9/GR5	
PTRVIR01	-101.20	1	-65.85	18.12	0.80	0.80	90	1	60.5	1 6 9/GR20	
PTRVIR02	-110.20	1	-65.86	18.12	0.80	0.80	90	1	61.0	1 6 9/GR21	
SPMFRAN3	-53.20	1	-67.24	47.51	3.16	0.80	7	1	60.4	2 7	10
TRD00001	-84.70	1	-61.23	10.70	0.80	0.80	90	1	59.4		
URG00001	-71.70	1	-56.22	-32.52	1.02	0.89	11	1	60.0		
USAEH001	-61.70	1	-85.19	36.21	5.63	3.33	22	1	61.8	1 5 6	10
USAEH002	-101.20	1	-89.24	36.16	5.67	3.76	170	1	61.7	1 6 9/GR20	10
USAEH003	-110.20	1	-90.14	36.11	5.55	3.55	161	1	62.0	1 6 9/GR21	10
USAEH004	-119.20	1	-91.16	36.05	5.38	3.24	152	1	62.6	1 5 6	10
USAPSA02	-166.20	1	-117.80	40.58	4.03	0.82	135	1	63.2	9/GR1	
USAPSA03	-175.20	1	-118.27	40.12	3.62	0.80	136	1	65.0	9/GR2	
USAWH101	-148.20	1	-109.65	38.13	5.53	1.95	142	1	62.1	10	
USAWH102	-157.20	1	-111.41	38.57	5.51	1.54	138	1	63.2	10	
VENAND03	-115.20	1	-67.04	6.91	2.37	1.43	111	1	62.2	9/GR5	
VRG00001	-79.70	1	-64.37	18.48	0.80	0.80	90	1	58.3	4	



1	2	3	4		5		6	7	8	9	
ALS00002	-165.80	2	-149.63	58.52	3.81	1.23	171	2	59.7	9/GR1	10
ALS00003	-174.80	2	-150.95	58.54	3.77	1.11	167	2	60.0	9/GR2	10
ARGNORT4	-93.80	2	-63.96	-30.01	3.86	1.99	48	2	65.6	10	
ARGNORT5	-54.80	2	-62.85	-29.80	3.24	2.89	47	2	63.5	10	
ATNBEAM1	-52.80	2	-66.44	14.87	1.83	0.80	39	2	61.0		
B CE311	-63.80	2	-40.60	-6.07	3.04	2.06	174	2	61.6	8 9/GR7	
B CE312	-44.80	2	-40.26	-6.06	3.44	2.09	174	2	61.0	8 9/GR9	10
B CE411	-63.80	2	-50.97	-15.26	3.86	1.38	49	2	62.6	8 9/GR7	10
B CE412	-44.80	2	-50.71	-15.30	3.57	1.56	52	2	62.7	8 9/GR9	10
B CE511	-63.80	2	-53.11	-2.98	2.42	2.15	107	2	63.1	8 9/GR7	10
B NO611	-73.80	2	-59.60	-11.62	2.86	1.69	165	1	62.8	8 9/GR8	10
B NO711	-73.80	2	-60.70	-1.78	3.54	1.78	126	1	62.8	8 9/GR8	10
B NO811	-73.80	2	-68.75	-4.71	2.37	1.65	73	1	62.8	8 9/GR8	10
B SE911	-101.80	2	-45.99	-19.09	2.22	0.80	62	2	65.3	8	10
B SU111	-80.80	2	-51.10	-25.64	2.76	1.06	50	2	62.8	8 9/GR6	10
B SU112	-44.80	2	-50.76	-25.62	2.47	1.48	56	2	62.3	8 9/GR9	
B SU211	-80.80	2	-44.51	-16.94	3.22	1.37	60	2	62.5	8 9/GR6	10
B SU212	-44.80	2	-43.99	-16.97	3.27	1.92	59	2	61.3	8 9/GR9	
CAN01101	-137.80	2	-125.60	57.24	3.45	1.27	157	2	59.5	9/GR10	10
CAN01201	-137.80	2	-111.92	55.89	3.33	0.98	151	2	59.6	9/GR10	10
CAN01202	-72.30	2	-107.64	55.62	2.75	1.11	32	2	59.6		
CAN01203	-128.80	2	-111.43	55.56	3.07	1.15	151	2	59.5	9/GR12	10
CAN01303	-128.80	2	-102.39	57.12	3.54	0.92	154	2	60.0	9/GR12	10
CAN01304	-90.80	2	-99.00	57.33	1.96	1.73	1	2	59.8	9/GR13	
CAN01403	-128.80	2	-89.70	52.02	4.67	0.80	148	2	61.8	9/GR12	10
CAN01404	-90.80	2	-84.78	52.41	3.09	2.06	153	2	60.4	9/GR13	10
CAN01405	-81.80	2	-84.02	52.34	2.82	2.30	172	2	60.3	9/GR14	10
CAN01504	-90.80	2	-72.68	53.78	3.57	1.67	157	2	60.2	9/GR13	10
CAN01505	-81.80	2	-71.76	53.76	3.30	1.89	162	2	60.1	9/GR14	10
CAN01605	-81.80	2	-61.54	49.50	2.66	1.39	144	2	60.3	9/GR14	10
CAN01606	-70.30	2	-61.32	49.51	2.41	1.65	148	2	60.2	10	
CHLCONT4	-105.80	2	-69.59	-23.20	2.21	0.80	68	2	59.1	9/GR16	
CHLCONT6	-105.80	2	-73.52	-55.52	3.65	1.31	39	2	59.6	9/GR16	
CRBBAH01	-92.30	2	-76.09	24.13	1.83	0.80	141	1	61.7	9/GR18	
CRBBER01	-92.30	2	-64.76	32.13	0.80	0.80	90	1	56.7	9/GR18	
CRBBLZ01	-92.30	2	-88.61	17.26	0.80	0.80	90	1	58.6	9/GR18	
CRBEC001	-92.30	2	-60.07	8.26	4.20	0.86	115	1	64.2	9/GR18	10
CRBJMC01	-92.30	2	-79.45	17.97	0.99	0.80	151	1	61.1	9/GR18	
CTR00201	-130.80	2	-84.33	9.67	0.82	0.80	119	2	65.6		
EQAC0001	-94.80	2	-78.31	-1.52	1.48	1.15	65	1	63.0	9/GR19	
EQAG0001	-94.80	2	-90.36	-0.57	0.94	0.89	99	1	61.0	9/GR19	
GUY00302	-33.80	2	-59.07	4.77	1.43	0.85	91	2	63.5		
HNDIFRB2	-107.30	2	-86.23	15.16	1.14	0.85	8	1	63.4		
HTI00002	-83.30	2	-73.28	18.96	0.82	0.80	11	2	60.9		
HWA00002	-165.80	2	-165.79	23.32	4.20	0.80	160	2	58.8	9/GR1	10
HWA00003	-174.80	2	-166.10	23.42	4.25	0.80	159	2	58.8	9/GR2	10
MEX01NTE	-77.80	2	-105.80	25.99	2.88	2.07	155	2	60.5	1	
MEX02NTE	-135.80	2	-107.36	26.32	3.80	1.57	149	2	61.2	1	10
MEX02SUR	-126.80	2	-96.39	19.88	3.19	1.87	158	2	62.5	1	10
PRU00004	-85.80	2	-74.19	-8.39	3.74	2.45	112	2	62.8	10	
PTRVIR01	-100.80	2	-65.85	18.12	0.80	0.80	90	2	60.6	1 6 9/GR20	
PTRVIR02	-109.80	2	-65.85	18.12	0.80	0.80	90	2	61.1	1 6 9/GR21	
TCA00001	-115.80	2	-71.79	21.53	0.80	0.80	90	2	60.4		
USAEH001	-61.30	2	-85.16	36.21	5.63	3.32	22	2	61.8	1 5 6	10
USAEH002	-100.80	2	-89.28	36.16	5.65	3.78	170	2	61.7	1 6 9/GR20	10
USAEH003	-109.80	2	-90.12	36.11	5.55	3.56	161	2	62.1	1 6 9/GR21	10
USAEH004	-118.80	2	-91.16	36.05	5.38	3.24	153	2	62.6	1 5 6	10
USAPSA02	-165.80	2	-117.79	40.58	4.04	0.82	135	2	63.2	9/GR1	
USAPSA03	-174.80	2	-118.20	40.15	3.63	0.80	136	2	64.9	9/GR2	
USAWH101	-147.80	2	-109.70	38.13	5.52	1.96	142	2	62.1	10	
USAWH102	-156.80	2	-111.40	38.57	5.51	1.55	138	2	63.2	10	
VCT00001	-79.30	2	-61.18	13.23	0.80	0.80	90	2	58.4		
VEN11VEN	-103.80	2	-66.79	6.90	2.50	1.77	122	2	65.1	10	

12 253.16 MHz (3)

1	2	3	4		5		6	7	8	9	
ALS00002	-166.20	3	-149.66	58.37	3.76	1.24	170	1	59.8	9/GR1	10
ALS00003	-175.20	3	-150.98	58.53	3.77	1.11	167	1	60.0	9/GR2	10
ARGINSU4	-94.20	3	-52.98	-59.81	3.40	0.80	19	1	59.9	9/GR3	
ARGINSU5	-55.20	3	-44.17	-59.91	3.77	0.80	13	1	59.3	9/GR4	10
ARGSUR04	-94.20	3	-65.04	-43.33	3.32	1.50	40	1	60.7	9/GR3	10
ARGSUR05	-55.20	3	-63.68	-43.01	2.54	2.38	152	1	60.1	9/GR4	10
ATGSJN01	-79.70	3	-61.79	17.07	0.80	0.80	90	1	58.4		
B CE311	-64.20	3	-40.60	-6.07	3.04	2.06	174	1	61.6	8 9/GR7	10
B CE312	-45.20	3	-40.27	-6.06	3.44	2.09	174	1	61.0	8 9/GR9	10
B CE411	-64.20	3	-50.97	-15.27	3.86	1.38	49	1	62.6	8 9/GR7	10
B CE412	-45.20	3	-50.71	-15.30	3.57	1.56	52	1	62.7	8 9/GR9	10
B CE511	-64.20	3	-53.10	-2.90	2.44	2.13	104	1	63.1	8 9/GR7	10
B NO611	-74.20	3	-59.60	-11.62	2.85	1.69	165	2	62.9	8 9/GR8	10
B NO711	-74.20	3	-60.70	-1.78	3.54	1.78	126	2	62.8	8 9/GR8	10
B NO811	-74.20	3	-68.76	-4.71	2.37	1.65	73	2	62.8	8 9/GR8	
B SU111	-81.20	3	-51.12	-25.63	2.76	1.05	50	1	62.9	8 9/GR6	10
B SU112	-45.20	3	-50.75	-25.62	2.47	1.48	56	1	62.3	8 9/GR9	
B SU211	-81.20	3	-44.51	-16.95	3.22	1.36	60	1	62.5	8 9/GR6	10
B SU212	-45.20	3	-44.00	-16.87	3.20	1.96	58	1	61.3	8 9/GR9	
BERBERMU	-96.20	3	-64.77	32.32	0.80	0.80	90	2	56.8		
BOLAND01	-115.20	3	-65.04	-16.76	2.49	1.27	76	1	67.9	9/GR5	
BOL00001	-87.20	3	-64.61	-16.71	2.52	2.19	85	1	63.8	10	
BRB00001	-92.70	3	-59.85	12.93	0.80	0.80	90	2	59.1		
CAN01101	-138.20	3	-125.63	57.24	3.45	1.27	157	1	59.5	9/GR10	10
CAN01201	-138.20	3	-112.04	55.95	3.35	0.97	151	1	59.6	9/GR10	10
CAN01202	-72.70	3	-107.70	55.63	2.74	1.12	32	1	59.6		
CAN01203	-129.20	3	-111.48	55.61	3.08	1.15	151	1	59.5	9/GR12	10
CAN01303	-129.20	3	-102.42	57.12	3.54	0.91	154	1	60.1	9/GR12	10
CAN01304	-91.20	3	-99.12	57.36	1.98	1.72	2	1	59.8	9/GR13	
CAN01403	-129.20	3	-89.75	52.02	4.68	0.80	148	1	61.8	9/GR12	10
CAN01404	-91.20	3	-84.82	52.42	3.10	2.05	152	1	60.4	9/GR13	10
CAN01405	-82.20	3	-84.00	52.39	2.84	2.29	172	1	60.3	9/GR14	10
CAN01504	-91.20	3	-72.66	53.77	3.57	1.67	156	1	60.2	9/GR13	10
CAN01505	-82.20	3	-71.77	53.79	3.30	1.89	162	1	60.1	9/GR14	10
CAN01605	-82.20	3	-61.50	49.55	2.65	1.40	143	1	60.3	9/GR14	10
CAN01606	-70.70	3	-61.30	49.55	2.40	1.65	148	1	60.2	10	
CHLCONT5	-106.20	3	-72.23	-35.57	2.60	0.80	55	1	59.4	9/GR17	
CHLPAC02	-106.20	3	-80.06	-30.06	1.36	0.80	69	1	59.2	9/GR17	
CLMAND01	-115.20	3	-74.72	5.93	3.85	1.63	114	1	65.0	9/GR5	
CLM00001	-103.20	3	-74.50	5.87	3.98	1.96	118	1	63.6	10	
CUB00001	-89.20	3	-79.81	21.62	2.24	0.80	168	1	61.1		
EQACAND1	-115.20	3	-78.40	-1.61	1.37	0.95	75	1	64.1	9/GR5	
EQAGAND1	-115.20	3	-90.34	-0.62	0.90	0.81	89	1	61.3	9/GR5	
GRD00002	-42.20	3	-61.58	12.29	0.80	0.80	90	1	58.8		
GRD00059	-57.20	3	-61.58	12.29	0.80	0.80	90	1	58.5		
GRLDNK01	-53.20	3	-44.89	66.56	2.70	0.82	173	1	60.0	2	10
HWA00002	-166.20	3	-165.79	23.42	4.20	0.80	160	1	58.8	9/GR1	10
HWA00003	-175.20	3	-166.10	23.42	4.25	0.80	159	1	58.8	9/GR2	10
MEX01NTE	-78.20	3	-105.81	26.01	2.89	2.08	155	1	60.5	1	
MEX01SUR	-69.20	3	-94.84	19.82	3.05	2.09	4	1	62.3	1	10
MEX02NTE	-136.20	3	-107.21	26.31	3.84	1.55	148	1	61.2	1	10
MEX02SUR	-127.20	3	-96.39	19.88	3.18	1.87	157	1	62.6	1	10
PAQPAC01	-106.20	3	-109.18	-27.53	0.80	0.80	90	1	56.2	9/GR17	
PRG00002	-99.20	3	-58.66	-23.32	1.45	1.04	76	1	60.2		
PRUAND02	-115.20	3	-74.69	-8.39	3.41	1.79	95	1	64.0	9/GR5	
PTRVIR01	-101.20	3	-65.85	18.12	0.80	0.80	90	1	60.6	1 6 9/GR20	
PTRVIR02	-110.20	3	-65.86	18.12	0.80	0.80	90	1	61.0	1 6 9/GR21	
SURINAM2	-84.70	3	-55.69	4.35	1.00	0.80	86	1	63.2		
URG00001	-71.70	3	-56.22	-32.52	1.02	0.89	11	1	60.0		
USAEH001	-61.70	3	-85.19	36.21	5.63	3.33	22	1	61.8	1 5 6	10
USAEH002	-101.20	3	-89.24	36.16	5.67	3.76	170	1	61.7	1 6 9/GR20	10
USAEH003	-110.20	3	-90.14	36.11	5.55	3.55	161	1	62.1	1 6 9/GR21	10
USAEH004	-119.20	3	-91.16	36.05	5.38	3.24	152	1	62.6	1 5 6	10
USAPSA02	-166.20	3	-117.80	40.58	4.03	0.82	135	1	63.3	9/GR1	
USAPSA03	-175.20	3	-118.27	40.12	3.62	0.80	136	1	65.0	9/GR2	
USAWH101	-148.20	3	-109.65	38.13	5.53	1.95	142	1	62.1	10	
USAWH102	-157.20	3	-111.41	38.57	5.51	1.54	138	1	63.2	10	
VENAND03	-115.20	3	-67.04	6.91	2.37	1.43	111	1	67.3	9/GR5	

1	2	3	4		5		6	7	8	9	
ALS00002	-165.80	4	-149.63	58.52	3.81	1.23	171	2	59.8	9/GR1	10
ALS00003	-174.80	4	-150.95	58.54	3.77	1.11	167	2	60.0	9/GR2	10
ARGNORT4	-93.80	4	-63.96	-30.01	3.86	1.99	48	2	65.7	10	
ARGNORT5	-54.80	4	-62.85	-29.80	3.24	2.89	47	2	63.5	10	
B CE311	-63.80	4	-40.60	-6.07	3.04	2.06	174	2	61.6	8 9/GR7	10
B CE312	-44.80	4	-40.26	-6.06	3.44	2.09	174	2	61.0	8 9/GR9	10
B CE411	-63.80	4	-50.97	-15.26	3.86	1.38	49	2	62.6	8 9/GR7	10
B CE412	-44.80	4	-50.71	-15.30	3.57	1.56	52	2	62.8	8 9/GR9	10
B CE511	-63.80	4	-53.11	-2.98	2.42	2.15	107	2	63.1	8 9/GR7	10
B NO611	-73.80	4	-59.60	-11.62	2.86	1.69	165	1	62.9	8 9/GR8	10
B NO711	-73.80	4	-60.70	-1.78	3.54	1.78	126	1	62.8	8 9/GR8	10
B NO811	-73.80	4	-68.75	-4.71	2.37	1.65	73	1	62.8	8 9/GR8	10
B SE911	-101.80	4	-45.99	-19.09	2.22	0.80	62	2	65.3	8	10
B SU111	-80.80	4	-51.10	-25.64	2.76	1.06	50	2	62.9	8 9/GR6	10
B SU112	-44.80	4	-50.76	-25.62	2.47	1.48	56	2	62.3	8 9/GR9	10
B SU211	-80.80	4	-44.51	-16.94	3.22	1.37	60	2	62.5	8 9/GR6	10
B SU212	-44.80	4	-43.99	-16.97	3.27	1.92	59	2	61.3	8 9/GR9	10
CAN01101	-137.80	4	-125.60	57.24	3.45	1.27	157	2	59.5	9/GR10	10
CAN01201	-137.80	4	-111.92	55.89	3.33	0.98	151	2	59.6	9/GR10	10
CAN01202	-72.30	4	-107.64	55.62	2.75	1.11	32	2	59.6		
CAN01203	-128.80	4	-111.43	55.56	3.07	1.15	151	2	59.5	9/GR12	10
CAN01303	-128.80	4	-102.39	57.12	3.54	0.92	154	2	60.1	9/GR12	10
CAN01304	-90.80	4	-99.00	57.33	1.96	1.73	1	2	59.8	9/GR13	10
CAN01403	-128.80	4	-89.70	52.02	4.67	0.80	148	2	61.8	9/GR12	10
CAN01404	-90.80	4	-84.78	52.41	3.09	2.06	153	2	60.4	9/GR13	10
CAN01405	-81.80	4	-84.02	52.34	2.82	2.30	172	2	60.3	9/GR14	10
CAN01504	-90.80	4	-72.68	53.78	3.57	1.67	157	2	60.2	9/GR13	10
CAN01505	-81.80	4	-71.76	53.76	3.30	1.89	162	2	60.2	9/GR14	10
CAN01605	-81.80	4	-61.54	49.50	2.66	1.39	144	2	60.3	9/GR14	10
CAN01606	-70.30	4	-61.32	49.51	2.41	1.65	148	2	60.2	10	
CHLCONT4	-105.80	4	-69.59	-23.20	2.21	0.80	68	2	59.1	9/GR16	10
CHLCONT6	-105.80	4	-73.52	-55.52	3.65	1.31	39	2	59.6	9/GR16	10
CRBBAH01	-92.30	4	-76.09	24.13	1.83	0.80	141	1	61.7	9/GR18	10
CRBBER01	-92.30	4	-64.76	32.13	0.80	0.80	90	1	56.8	9/GR18	10
CRBBLZ01	-92.30	4	-88.61	17.26	0.80	0.80	90	1	58.7	9/GR18	10
CRBEC001	-92.30	4	-60.07	8.26	4.20	0.86	115	1	64.3	9/GR18	10
CRBJMC01	-92.30	4	-79.45	17.97	0.99	0.80	151	1	61.1	9/GR18	10
CYM00001	-115.80	4	-80.58	19.57	0.80	0.80	90	2	59.6		
DOMIFRB2	-83.30	4	-70.51	18.79	0.98	0.80	167	2	61.1		
EQAC0001	-94.80	4	-78.31	-1.52	1.48	1.15	65	1	63.0	9/GR19	10
EQAG0001	-94.80	4	-90.36	-0.57	0.94	0.89	99	1	61.0	9/GR19	10
GUFMG002	-52.80	4	-56.42	8.47	4.16	0.81	123	2	62.7	2 7	10
HWA00002	-165.80	4	-165.79	23.32	4.20	0.80	160	2	58.8	9/GR1	10
HWA00003	-174.80	4	-166.10	23.42	4.25	0.80	159	2	58.8	9/GR2	10
JMC00005	-33.80	4	-77.27	18.12	0.80	0.80	90	2	60.6		
LCAIFRB1	-79.30	4	-61.15	13.90	0.80	0.80	90	2	58.4		
MEX01NTE	-77.80	4	-105.80	25.99	2.88	2.07	155	2	60.5	1	
MEX02NTE	-135.80	4	-107.36	26.32	3.80	1.57	149	2	61.2	1	10
MEX02SUR	-126.80	4	-96.39	19.88	3.19	1.87	158	2	62.5	1	10
PRU00004	-85.80	4	-74.19	-8.39	3.74	2.45	112	2	62.9	10	
PTRVIR01	-100.80	4	-65.85	18.12	0.80	0.80	90	2	60.6	1 6 9/GR20	
PTRVIR02	-109.80	4	-65.85	18.12	0.80	0.80	90	2	61.1	1 6 9/GR21	
SLVIFRB2	-107.30	4	-88.91	13.59	0.80	0.80	90	1	61.7		
USAEH001	-61.30	4	-85.16	36.21	5.63	3.32	22	2	61.9	1 5 6	10
USAEH002	-100.80	4	-89.28	36.16	5.65	3.78	170	2	61.7	1 6 9/GR20	10
USAEH003	-109.80	4	-90.12	36.11	5.55	3.56	161	2	62.1	1 6 9/GR21	10
USAEH004	-118.80	4	-91.16	36.05	5.38	3.24	153	2	62.6	1 5 6	10
USAPSA02	-165.80	4	-117.79	40.58	4.04	0.82	135	2	63.3	9/GR1	10
USAPSA03	-174.80	4	-118.20	40.15	3.63	0.80	136	2	65.0	9/GR2	10
USAWH101	-147.80	4	-109.70	38.13	5.52	1.96	142	2	62.1	10	
USAWH102	-156.80	4	-111.40	38.57	5.51	1.55	138	2	63.2	10	
VEN11VEN	-103.80	4	-66.79	6.90	2.50	1.77	122	2	65.2	10	

12 282.32 MHz (5)

1	2	3	4		5		6	7	8	9	
ALS00002	-166.20	5	-149.66	58.37	3.76	1.24	170	1	59.7	9/GR1	10
ALS00003	-175.20	5	-150.98	58.53	3.77	1.11	167	1	60.0	9/GR2	10
ARGINSU4	-94.20	5	-52.98	-59.81	3.40	0.80	19	1	59.9	9/GR3	
ARGSUR04	-94.20	5	-65.04	-43.33	3.32	1.50	40	1	60.7	9/GR3	10
B CE311	-64.20	5	-40.60	-6.07	3.04	2.06	174	1	61.6	89/GR7	10
B CE312	-45.20	5	-40.27	-6.06	3.44	2.09	174	1	61.0	89/GR9	10
B CE411	-64.20	5	-50.97	-15.27	3.86	1.38	49	1	62.6	89/GR7	10
B CE412	-45.20	5	-50.71	-15.30	3.57	1.56	52	1	62.7	89/GR9	10
B CE511	-64.20	5	-53.10	-2.90	2.44	2.13	104	1	63.0	89/GR7	10
B NO611	-74.20	5	-59.60	-11.62	2.85	1.69	165	2	62.8	89/GR8	10
B NO711	-74.20	5	-60.70	-1.78	3.54	1.78	126	2	62.8	89/GR8	10
B NO811	-74.20	5	-68.76	-4.71	2.37	1.65	73	2	62.8	89/GR8	10
B SU111	-81.20	5	-51.12	-25.63	2.76	1.05	50	1	62.8	89/GR6	10
B SU112	-45.20	5	-50.75	-25.62	2.47	1.48	56	1	62.2	89/GR9	
B SU211	-81.20	5	-44.51	-16.95	3.22	1.36	60	1	62.5	89/GR6	10
B SU212	-45.20	5	-44.00	-16.87	3.20	1.96	58	1	61.3	89/GR9	
BAHIFRB1	-87.20	5	-76.06	24.16	1.81	0.80	142	1	61.6		
BERBERMU	-96.20	5	-64.77	32.32	0.80	0.80	90	2	56.8		
BERBER02	-31.00	5	-64.77	32.32	0.80	0.80	90	1	56.9	2	10
BOLAND01	-115.20	5	-65.04	-16.76	2.49	1.27	76	1	67.9	9/GR5	
CAN01101	-138.20	5	-125.63	57.24	3.45	1.27	157	1	59.5	9/GR10	10
CAN01201	-138.20	5	-112.04	55.95	3.35	0.97	151	1	59.6	9/GR10	10
CAN01202	-72.70	5	-107.70	55.63	2.74	1.12	32	1	59.6		
CAN01203	-129.20	5	-111.48	55.61	3.08	1.15	151	1	59.5	9/GR12	10
CAN01303	-129.20	5	-102.42	57.12	3.54	0.91	154	1	60.0	9/GR12	10
CAN01304	-91.20	5	-99.12	57.36	1.98	1.72	2	1	59.8	9/GR13	
CAN01403	-129.20	5	-89.75	52.02	4.68	0.80	148	1	61.8	9/GR12	10
CAN01404	-91.20	5	-84.82	52.42	3.10	2.05	152	1	60.4	9/GR13	10
CAN01405	-82.20	5	-84.00	52.39	2.84	2.29	172	1	60.3	9/GR14	10
CAN01504	-91.20	5	-72.66	53.77	3.57	1.67	156	1	60.2	9/GR13	10
CAN01505	-82.20	5	-71.77	53.79	3.30	1.89	162	1	60.1	9/GR14	10
CAN01605	-82.20	5	-61.50	49.55	2.65	1.40	143	1	60.3	9/GR14	10
CAN01606	-70.70	5	-61.30	49.55	2.40	1.65	148	1	60.2	10	
CHLCONT5	-106.20	5	-72.23	-35.57	2.60	0.80	55	1	59.4	9/GR17	
CHLPAC02	-106.20	5	-80.06	-30.06	1.36	0.80	69	1	59.2	9/GR17	
CLMAND01	-115.20	5	-74.72	5.93	3.85	1.63	114	1	64.9	9/GR5	
CLM00001	-103.20	5	-74.50	5.87	3.98	1.96	118	1	63.5	10	
EQACAND1	-115.20	5	-78.40	-1.61	1.37	0.95	75	1	64.0	9/GR5	
EQAGAND1	-115.20	5	-90.34	-0.62	0.90	0.81	89	1	61.3	9/GR5	
FLKANT01	-57.20	5	-44.54	-60.13	3.54	0.80	12	1	59.3	2	10
FLKFALKS	-31.00	5	-59.90	-51.64	0.80	0.80	90	1	58.1	2	
GRD00002	-42.20	5	-61.58	12.29	0.80	0.80	90	1	58.8		
HWA00002	-166.20	5	-165.79	23.42	4.20	0.80	160	1	58.8	9/GR1	10
HWA00003	-175.20	5	-166.10	23.42	4.25	0.80	159	1	58.8	9/GR2	10
MEX01NTE	-78.20	5	-105.81	26.01	2.89	2.08	155	1	60.5	1	
MEX01SUR	-69.20	5	-94.84	19.82	3.05	2.09	4	1	62.2	1	10
MEX02NTE	-136.20	5	-107.21	26.31	3.84	1.55	148	1	61.2	1	10
MEX02SUR	-127.20	5	-96.39	19.88	3.18	1.87	157	1	62.5	1	10
PAQPAC01	-106.20	5	-109.18	-27.53	0.80	0.80	90	1	56.2	9/GR17	
PRG00002	-99.20	5	-58.66	-23.32	1.45	1.04	76	1	60.2		
PRUAND02	-115.20	5	-74.69	-8.39	3.41	1.79	95	1	63.9	9/GR5	
PTRVIR01	-101.20	5	-65.85	18.12	0.80	0.80	90	1	60.5	169/GR20	
PTRVIR02	-110.20	5	-65.86	18.12	0.80	0.80	90	1	61.0	169/GR21	
SPMFRAN3	-53.20	5	-67.24	47.51	3.16	0.80	7	1	60.4	27	10
TRD00001	-84.70	5	-61.23	10.70	0.80	0.80	90	1	59.4		
URG00001	-71.70	5	-56.22	-32.52	1.02	0.89	11	1	60.0		
USAEH001	-61.70	5	-85.19	36.21	5.63	3.33	22	1	61.8	156	10
USAEH002	-101.20	5	-89.24	36.16	5.67	3.76	170	1	61.7	169/GR20	10
USAEH003	-110.20	5	-90.14	36.11	5.55	3.55	161	1	62.0	169/GR21	10
USAEH004	-119.20	5	-91.16	36.05	5.38	3.24	152	1	62.6	156	10
USAPSA02	-166.20	5	-117.80	40.58	4.03	0.82	135	1	63.2	9/GR1	
USAPSA03	-175.20	5	-118.27	40.12	3.62	0.80	136	1	65.0	9/GR2	
USAWH101	-148.20	5	-109.65	38.13	5.53	1.95	142	1	62.1	10	
USAWH102	-157.20	5	-111.41	38.57	5.51	1.54	138	1	63.2	10	
VENAND03	-115.20	5	-67.04	6.91	2.37	1.43	111	1	67.2	9/GR5	
VRG00001	-79.70	5	-64.37	18.48	0.80	0.80	90	1	58.3	4	

1	2	3	4		5		6	7	8	9	
ALS00002	-165.80	6	-149.63	58.52	3.81	1.23	171	2	59.7	9/GR1	10
ALS00003	-174.80	6	-150.95	58.54	3.77	1.11	167	2	60.0	9/GR2	10
ARGNORT4	-93.80	6	-63.96	-30.01	3.86	1.99	48	2	65.6	10	
ARGNORT5	-54.80	6	-62.85	-29.80	3.24	2.89	47	2	63.5	10	
ATNBEAM1	-52.80	6	-66.44	14.87	1.83	0.80	39	2	61.0		
B CE311	-63.80	6	-40.60	-6.07	3.04	2.06	174	2	61.6	8 9/GR7	10
B CE312	-44.80	6	-40.26	-6.06	3.44	2.09	174	2	61.0	8 9/GR9	10
B CE411	-63.80	6	-50.97	-15.26	3.86	1.38	49	2	62.6	8 9/GR7	10
B CE412	-44.80	6	-50.71	-15.30	3.57	1.56	52	2	62.7	8 9/GR9	10
B CE511	-63.80	6	-53.11	-2.98	2.42	2.15	107	2	63.1	8 9/GR7	10
B NO611	-73.80	6	-59.60	-11.62	2.86	1.69	165	1	62.8	8 9/GR8	10
B NO711	-73.80	6	-60.70	-1.78	3.54	1.78	126	1	62.8	8 9/GR8	10
B NO811	-73.80	6	-68.75	-4.71	2.37	1.65	73	1	62.8	8 9/GR8	10
B SE911	-101.80	6	-45.99	-19.09	2.22	0.80	62	2	65.3	8	10
B SU111	-80.80	6	-51.10	-25.64	2.76	1.06	50	2	62.8	8 9/GR6	10
B SU112	-44.80	6	-50.76	-25.62	2.47	1.48	56	2	62.3	8 9/GR9	10
B SU211	-80.80	6	-44.51	-16.94	3.22	1.37	60	2	62.5	8 9/GR6	10
B SU212	-44.80	6	-43.99	-16.97	3.27	1.92	59	2	61.3	8 9/GR9	10
CAN01101	-137.80	6	-125.60	57.24	3.45	1.27	157	2	59.5	9/GR10	10
CAN01201	-137.80	6	-111.92	55.89	3.33	0.98	151	2	59.6	9/GR10	10
CAN01202	-72.30	6	-107.64	55.62	2.75	1.11	32	2	59.6		
CAN01203	-128.80	6	-111.43	55.56	3.07	1.15	151	2	59.5	9/GR12	10
CAN01303	-128.80	6	-102.39	57.12	3.54	0.92	154	2	60.0	9/GR12	10
CAN01304	-90.80	6	-99.00	57.33	1.96	1.73	1	2	59.8	9/GR13	10
CAN01403	-128.80	6	-89.70	52.02	4.67	0.80	148	2	61.8	9/GR12	10
CAN01404	-90.80	6	-84.78	52.41	3.09	2.06	153	2	60.4	9/GR13	10
CAN01405	-81.80	6	-84.02	52.34	2.82	2.30	172	2	60.3	9/GR14	10
CAN01504	-90.80	6	-72.68	53.78	3.57	1.67	157	2	60.2	9/GR13	10
CAN01505	-81.80	6	-71.76	53.76	3.30	1.89	162	2	60.1	9/GR14	10
CAN01605	-81.80	6	-61.54	49.50	2.66	1.39	144	2	60.3	9/GR14	10
CAN01606	-70.30	6	-61.32	49.51	2.41	1.65	148	2	60.2	10	
CHLCONT4	-105.80	6	-69.59	-23.20	2.21	0.80	68	2	59.1	9/GR16	10
CHLCONT6	-105.80	6	-73.52	-55.52	3.65	1.31	39	2	59.6	9/GR16	10
CRBBAH01	-92.30	6	-76.09	24.13	1.83	0.80	141	1	61.7	9/GR18	10
CRBBER01	-92.30	6	-64.76	32.13	0.80	0.80	90	1	56.7	9/GR18	10
CRBBLZ01	-92.30	6	-88.61	17.26	0.80	0.80	90	1	58.6	9/GR18	10
CRBEC001	-92.30	6	-60.07	8.26	4.20	0.86	115	1	64.2	9/GR18	10
CRBJMC01	-92.30	6	-79.45	17.97	0.99	0.80	151	1	61.1	9/GR18	10
CTR00201	-130.80	6	-84.33	9.67	0.82	0.80	119	2	65.6		
EQAC0001	-94.80	6	-78.31	-1.52	1.48	1.15	65	1	63.0	9/GR19	10
EQAG0001	-94.80	6	-90.36	-0.57	0.94	0.89	99	1	61.0	9/GR19	10
GUY00302	-33.80	6	-59.07	4.77	1.43	0.85	91	2	63.5		
HNDIFRB2	-107.30	6	-86.23	15.16	1.14	0.85	8	1	63.4		
HTI00002	-83.30	6	-73.28	18.96	0.82	0.80	11	2	60.9		
HWA00002	-165.80	6	-165.79	23.32	4.20	0.80	160	2	58.8	9/GR1	10
HWA00003	-174.80	6	-166.10	23.42	4.25	0.80	159	2	58.8	9/GR2	10
MEX01NTE	-77.80	6	-105.80	25.99	2.88	2.07	155	2	60.5	1	
MEX02NTE	-135.80	6	-107.36	26.32	3.80	1.57	149	2	61.2	1	10
MEX02SUR	-126.80	6	-96.39	19.88	3.19	1.87	158	2	62.5	1	10
PRU00004	-85.80	6	-74.19	-8.39	3.74	2.45	112	2	62.8	10	
PTRVIR01	-100.80	6	-65.85	18.12	0.80	0.80	90	2	60.6	1 6 9/GR20	10
PTRVIR02	-109.80	6	-65.85	18.12	0.80	0.80	90	2	61.1	1 6 9/GR21	10
TCA00001	-115.80	6	-71.79	21.53	0.80	0.80	90	2	60.4		
USAEH001	-61.30	6	-85.16	36.21	5.63	3.32	22	2	61.8	1 5 6	10
USAEH002	-100.80	6	-89.28	36.16	5.65	3.78	170	2	61.7	1 6 9/GR20	10
USAEH003	-109.80	6	-90.12	36.11	5.55	3.56	161	2	62.1	1 6 9/GR21	10
USAEH004	-118.80	6	-91.16	36.05	5.38	3.24	153	2	62.6	1 5 6	10
USAPSA02	-165.80	6	-117.79	40.58	4.04	0.82	135	2	63.2	9/GR1	10
USAPSA03	-174.80	6	-118.20	40.15	3.63	0.80	136	2	64.9	9/GR2	10
USAWH101	-147.80	6	-109.70	38.13	5.52	1.96	142	2	62.1	10	
USAWH102	-156.80	6	-111.40	38.57	5.51	1.55	138	2	63.2	10	
VCT00001	-79.30	6	-61.18	13.23	0.80	0.80	90	2	58.4		
VEN11VEN	-103.80	6	-66.79	6.90	2.50	1.77	122	2	65.1	10	

12 311.48 MHz (7)

1	2	3	4	5	6	7	8	9			
ALS00002	-166.20	7	-149.66	58.37	3.76	1.24	170	1	59.8	9/GR1	10
ALS00003	-175.20	7	-150.98	58.53	3.77	1.11	167	1	60.0	9/GR2	10
ARGINSU4	-94.20	7	-52.98	-59.81	3.40	0.80	19	1	59.9	9/GR3	
ARGINSU5	-55.20	7	-44.17	-59.91	3.77	0.80	13	1	59.3	9/GR4	10
ARGSUR04	-94.20	7	-65.04	-43.33	3.32	1.50	40	1	60.7	9/GR3	10
ARGSUR05	-55.20	7	-63.68	-43.01	2.54	2.38	152	1	60.1	9/GR4	10
ATGSJN01	-79.70	7	-61.79	17.07	0.80	0.80	90	1	58.4		
B CE311	-64.20	7	-40.60	-6.07	3.04	2.06	174	1	61.6	8 9/GR7	
B CE312	-45.20	7	-40.27	-6.06	3.44	2.09	174	1	61.0	8 9/GR9	10
B CE411	-64.20	7	-50.97	-15.27	3.86	1.38	49	1	62.6	8 9/GR7	10
B CE412	-45.20	7	-50.71	-15.30	3.57	1.56	52	1	62.7	8 9/GR9	10
B CE511	-64.20	7	-53.10	-2.90	2.44	2.13	104	1	63.1	8 9/GR7	10
B NO611	-74.20	7	-59.60	-11.62	2.85	1.69	165	2	62.9	8 9/GR8	10
B NO711	-74.20	7	-60.70	-1.78	3.54	1.78	126	2	62.8	8 9/GR8	10
B NO811	-74.20	7	-68.76	-4.71	2.37	1.65	73	2	62.8	8 9/GR8	
B SU111	-81.20	7	-51.12	-25.63	2.76	1.05	50	1	62.9	8 9/GR6	10
B SU112	-45.20	7	-50.75	-25.62	2.47	1.48	56	1	62.3	8 9/GR9	
B SU211	-81.20	7	-44.51	-16.95	3.22	1.36	60	1	62.5	8 9/GR6	10
B SU212	-45.20	7	-44.00	-16.87	3.20	1.96	58	1	61.3	8 9/GR9	
BERBERMU	-96.20	7	-64.77	32.32	0.80	0.80	90	2	56.8		
BOLAND01	-115.20	7	-65.04	-16.76	2.49	1.27	76	1	67.9	9/GR5	
BOL00001	-87.20	7	-64.61	-16.71	2.52	2.19	85	1	63.8	10	
BRB00001	-92.70	7	-59.85	12.93	0.80	0.80	90	2	59.1		
CAN01101	-138.20	7	-125.63	57.24	3.45	1.27	157	1	59.5	9/GR10	10
CAN01201	-138.20	7	-112.04	55.95	3.35	0.97	151	1	59.6	9/GR10	10
CAN01202	-72.70	7	-107.70	55.63	2.74	1.12	32	1	59.6		
CAN01203	-129.20	7	-111.48	55.61	3.08	1.15	151	1	59.5	9/GR12	10
CAN01303	-129.20	7	-102.42	57.12	3.54	0.91	154	1	60.1	9/GR12	10
CAN01304	-91.20	7	-99.12	57.36	1.98	1.72	2	1	59.8	9/GR13	
CAN01403	-129.20	7	-89.75	52.02	4.68	0.80	148	1	61.8	9/GR12	10
CAN01404	-91.20	7	-84.82	52.42	3.10	2.05	152	1	60.4	9/GR13	10
CAN01405	-82.20	7	-84.00	52.39	2.84	2.29	172	1	60.3	9/GR14	10
CAN01504	-91.20	7	-72.66	53.77	3.57	1.67	156	1	60.2	9/GR13	10
CAN01505	-82.20	7	-71.77	53.79	3.30	1.89	162	1	60.1	9/GR14	10
CAN01605	-82.20	7	-61.50	49.55	2.65	1.40	143	1	60.3	9/GR14	10
CAN01606	-70.70	7	-61.30	49.55	2.40	1.65	148	1	60.2	10	
CHLCONT5	-106.20	7	-72.23	-35.57	2.60	0.80	55	1	59.4	9/GR17	
CHLPAC02	-106.20	7	-80.06	-30.06	1.36	0.80	69	1	59.2	9/GR17	
CLMAND01	-115.20	7	-74.72	5.93	3.85	1.63	114	1	65.0	9/GR5	
CLM00001	-103.20	7	-74.50	5.87	3.98	1.96	118	1	63.6	10	
CUB00001	-89.20	7	-79.81	21.62	2.24	0.80	168	1	61.1		
EQACAND1	-115.20	7	-78.40	-1.61	1.37	0.95	75	1	64.1	9/GR5	
EQAGAND1	-115.20	7	-90.34	-0.62	0.90	0.81	89	1	61.3	9/GR5	
GRD00002	-42.20	7	-61.58	12.29	0.80	0.80	90	1	58.8		
GRD00059	-57.20	7	-61.58	12.29	0.80	0.80	90	1	58.5		
GRLDNK01	-53.20	7	-44.89	66.56	2.70	0.82	173	1	60.0	2	10
HWA00002	-166.20	7	-165.79	23.42	4.20	0.80	160	1	58.8	9/GR1	10
HWA00003	-175.20	7	-166.10	23.42	4.25	0.80	159	1	58.8	9/GR2	10
MEX01NTE	-78.20	7	-105.81	26.01	2.89	2.08	155	1	60.5	1	
MEX01SUR	-69.20	7	-94.84	19.82	3.05	2.09	4	1	62.3	1	10
MEX02NTE	-136.20	7	-107.21	26.31	3.84	1.55	148	1	61.2	1	10
MEX02SUR	-127.20	7	-96.39	19.88	3.18	1.87	157	1	62.6	1	10
PAQPAC01	-106.20	7	-109.18	-27.53	0.80	0.80	90	1	56.2	9/GR17	
PRG00002	-99.20	7	-58.66	-23.32	1.45	1.04	76	1	60.2		
PRUAND02	-115.20	7	-74.69	-8.39	3.41	1.79	95	1	64.0	9/GR5	
PTRVIR01	-101.20	7	-65.85	18.12	0.80	0.80	90	1	60.6	1 6 9/GR20	
PTRVIR02	-110.20	7	-65.86	18.12	0.80	0.80	90	1	61.0	1 6 9/GR21	
SURINAM2	-84.70	7	-55.69	4.35	1.00	0.80	86	1	63.2		
URG00001	-71.70	7	-56.22	-32.52	1.02	0.89	11	1	60.0		
USAEH001	-61.70	7	-85.19	36.21	5.63	3.33	22	1	61.8	1 5 6	10
USAEH002	-101.20	7	-89.24	36.16	5.67	3.76	170	1	61.7	1 6 9/GR20	10
USAEH003	-110.20	7	-90.14	36.11	5.55	3.55	161	1	62.1	1 6 9/GR21	10
USAEH004	-119.20	7	-91.16	36.05	5.38	3.24	152	1	62.6	1 5 6	10
USAPSA02	-166.20	7	-117.80	40.58	4.03	0.82	135	1	63.3	9/GR1	
USAPSA03	-175.20	7	-118.27	40.12	3.62	0.80	136	1	65.0	9/GR2	
USAWH101	-148.20	7	-109.65	38.13	5.53	1.95	142	1	62.1	10	
USAWH102	-157.20	7	-111.41	38.57	5.51	1.54	138	1	63.2	10	
VENAND03	-115.20	7	-67.04	6.91	2.37	1.43	111	1	67.3	9/GR5	

1	2	3	4		5		6	7	8	9	
ALS00002	-165.80	8	-149.63	58.52	3.81	1.23	171	2	59.8	9/GR1	10
ALS00003	-174.80	8	-150.95	58.54	3.77	1.11	167	2	60.0	9/GR2	10
ARGNORT4	-93.80	8	-63.96	-30.01	3.86	1.99	48	2	65.7	10	
ARGNORT5	-54.80	8	-62.85	-29.80	3.24	2.89	47	2	63.5	10	
B CE311	-63.80	8	-40.60	-6.07	3.04	2.06	174	2	61.6	8 9/GR7	10
B CE312	-44.80	8	-40.26	-6.06	3.44	2.09	174	2	61.0	8 9/GR9	10
B CE411	-63.80	8	-50.97	-15.26	3.86	1.38	49	2	62.6	8 9/GR7	10
B CE412	-44.80	8	-50.71	-15.30	3.57	1.56	52	2	62.8	8 9/GR9	10
B CE511	-63.80	8	-53.11	-2.98	2.42	2.15	107	2	63.1	8 9/GR7	10
B NO611	-73.80	8	-59.60	-11.62	2.86	1.69	165	1	62.9	8 9/GR8	10
B NO711	-73.80	8	-60.70	-1.78	3.54	1.78	126	1	62.8	8 9/GR8	10
B NO811	-73.80	8	-68.75	-4.71	2.37	1.65	73	1	62.8	8 9/GR8	10
B SE911	-101.80	8	-45.99	-19.09	2.22	0.80	62	2	65.3	8	10
B SU111	-80.80	8	-51.10	-25.64	2.76	1.06	50	2	62.9	8 9/GR6	10
B SU112	-44.80	8	-50.76	-25.62	2.47	1.48	56	2	62.3	8 9/GR9	
B SU211	-80.80	8	-44.51	-16.94	3.22	1.37	60	2	62.5	8 9/GR6	10
B SU212	-44.80	8	-43.99	-16.97	3.27	1.92	59	2	61.3	8 9/GR9	
CAN01101	-137.80	8	-125.60	57.24	3.45	1.27	157	2	59.5	9/GR10	10
CAN01201	-137.80	8	-111.92	55.89	3.33	0.98	151	2	59.6	9/GR10	10
CAN01202	-72.30	8	-107.64	55.62	2.75	1.11	32	2	59.6		
CAN01203	-128.80	8	-111.43	55.56	3.07	1.15	151	2	59.5	9/GR12	10
CAN01303	-128.80	8	-102.39	57.12	3.54	0.92	154	2	60.1	9/GR12	10
CAN01304	-90.80	8	-99.00	57.33	1.96	1.73	1	2	59.8	9/GR13	
CAN01403	-128.80	8	-89.70	52.02	4.67	0.80	148	2	61.8	9/GR12	10
CAN01404	-90.80	8	-84.78	52.41	3.09	2.06	153	2	60.4	9/GR13	10
CAN01405	-81.80	8	-84.02	52.34	2.82	2.30	172	2	60.3	9/GR14	10
CAN01504	-90.80	8	-72.68	53.78	3.57	1.67	157	2	60.2	9/GR13	10
CAN01505	-81.80	8	-71.76	53.76	3.30	1.89	162	2	60.2	9/GR14	10
CAN01605	-81.80	8	-61.54	49.50	2.66	1.39	144	2	60.3	9/GR14	10
CAN01606	-70.30	8	-61.32	49.51	2.41	1.65	148	2	60.2	10	
CHLCONT4	-105.80	8	-69.59	-23.20	2.21	0.80	68	2	59.1	9/GR16	
CHLCONT6	-105.80	8	-73.52	-55.52	3.65	1.31	39	2	59.6	9/GR16	
CRBBAH01	-92.30	8	-76.09	24.13	1.83	0.80	141	1	61.7	9/GR18	
CRBBER01	-92.30	8	-64.76	32.13	0.80	0.80	90	1	56.8	9/GR18	
CRBBLZ01	-92.30	8	-88.61	17.26	0.80	0.80	90	1	58.7	9/GR18	
CRBEC001	-92.30	8	-60.07	8.26	4.20	0.86	115	1	64.3	9/GR18	10
CRBJMC01	-92.30	8	-79.45	17.97	0.99	0.80	151	1	61.1	9/GR18	
CYM00001	-115.80	8	-80.58	19.57	0.80	0.80	90	2	59.6		
DOMIFRB2	-83.30	8	-70.51	18.79	0.98	0.80	167	2	61.1		
EQAC0001	-94.80	8	-78.31	-1.52	1.48	1.15	65	1	63.0	9/GR19	
EQAG0001	-94.80	8	-90.36	-0.57	0.94	0.89	99	1	61.0	9/GR19	
GUFMGG02	-52.80	8	-56.42	8.47	4.16	0.81	123	2	62.7	2 7	10
HWA00002	-165.80	8	-165.79	23.32	4.20	0.80	160	2	58.8	9/GR1	10
HWA00003	-174.80	8	-166.10	23.42	4.25	0.80	159	2	58.8	9/GR2	10
JMC00005	-33.80	8	-77.27	18.12	0.80	0.80	90	2	60.6		
LCAIFRB1	-79.30	8	-61.15	13.90	0.80	0.80	90	2	58.4		
MEX01NTE	-77.80	8	-105.80	25.99	2.88	2.07	155	2	60.5	1	
MEX02NTE	-135.80	8	-107.36	26.32	3.80	1.57	149	2	61.2	1	10
MEX02SUR	-126.80	8	-96.39	19.88	3.19	1.87	158	2	62.5	1	10
PRU00004	-85.80	8	-74.19	-8.39	3.74	2.45	112	2	62.9	10	
PTRVIR01	-100.80	8	-65.85	18.12	0.80	0.80	90	2	60.6	1 6 9/GR20	
PTRVIR02	-109.80	8	-65.85	18.12	0.80	0.80	90	2	61.1	1 6 9/GR21	
SLVIFRB2	-107.30	8	-88.91	13.59	0.80	0.80	90	1	61.7		
USAEH001	-61.30	8	-85.16	36.21	5.63	3.32	22	2	61.9	1 5 6	10
USAEH002	-100.80	8	-89.28	36.16	5.65	3.78	170	2	61.7	1 6 9/GR20	10
USAEH003	-109.80	8	-90.12	36.11	5.55	3.56	161	2	62.1	1 6 9/GR21	10
USAEH004	-118.80	8	-91.16	36.05	5.38	3.24	153	2	62.6	1 5 6	10
USAPSA02	-165.80	8	-117.79	40.58	4.04	0.82	135	2	63.3	9/GR1	
USAPSA03	-174.80	8	-118.20	40.15	3.63	0.80	136	2	63.0	9/GR2	
USAWH101	-147.80	8	-109.70	38.13	5.52	1.96	142	2	62.1	10	
USAWH102	-156.80	8	-111.40	38.57	5.51	1.55	138	2	63.2	10	
VEN11VEN	-103.80	8	-66.79	6.90	2.50	1.77	122	2	65.2	10	

12 340.64 MHz (9)

1	2	3	4		5		6	7	8	9	
ALS00002	-166.20	9	-149.66	58.37	3.76	1.24	170	1	59.7	9/GR1	10
ALS00003	-175.20	9	-150.98	58.53	3.77	1.11	167	1	60.0	9/GR2	10
ARGINSU4	-94.20	9	-52.98	-59.81	3.40	0.80	19	1	59.9	9/GR3	
ARGSUR04	-94.20	9	-65.04	-43.33	3.32	1.50	40	1	60.7	9/GR3	10
B CE311	-64.20	9	-40.60	-6.07	3.04	2.06	174	1	61.6	8 9/GR7	10
B CE312	-45.20	9	-40.27	-6.06	3.44	2.09	174	1	61.0	8 9/GR9	10
B CE411	-64.20	9	-50.97	-15.27	3.86	1.38	49	1	62.6	8 9/GR7	10
B CE412	-45.20	9	-50.71	-15.30	3.57	1.56	52	1	62.7	8 9/GR9	10
B CE511	-64.20	9	-53.10	-2.90	2.44	2.13	104	1	63.0	8 9/GR7	10
B NO611	-74.20	9	-59.60	-11.62	2.85	1.69	165	2	62.8	8 9/GR8	10
B NO711	-74.20	9	-60.70	-1.78	3.54	1.78	126	2	62.8	8 9/GR8	10
B NO811	-74.20	9	-68.76	-4.71	2.37	1.65	73	2	62.8	8 9/GR8	10
B SU111	-81.20	9	-51.12	-25.63	2.76	1.05	50	1	62.8	8 9/GR6	10
B SU112	-45.20	9	-50.75	-25.62	2.47	1.48	56	1	62.2	8 9/GR9	
B SU211	-81.20	9	-44.51	-16.95	3.22	1.36	60	1	62.5	8 9/GR6	10
B SU212	-45.20	9	-44.00	-16.87	3.20	1.96	58	1	61.3	8 9/GR9	
BAHIFRB1	-87.20	9	-76.06	24.16	1.81	0.80	142	1	61.6		
BERBERMU	-96.20	9	-64.77	32.32	0.80	0.80	90	2	56.8		
BERBER02	-31.00	9	-64.77	32.32	0.80	0.80	90	1	56.9	2	10
BOLAND01	-115.20	9	-65.04	-16.76	2.49	1.27	76	1	67.9	9/GR5	
CAN01101	-138.20	9	-125.63	57.24	3.45	1.27	157	1	59.5	9/GR10	10
CAN01201	-138.20	9	-112.04	55.95	3.35	0.97	151	1	59.6	9/GR10	10
CAN01202	-72.70	9	-107.70	55.63	2.74	1.12	32	1	59.6		
CAN01203	-129.20	9	-111.48	55.61	3.08	1.15	151	1	59.5	9/GR12	10
CAN01303	-129.20	9	-102.42	57.12	3.54	0.91	154	1	60.0	9/GR12	10
CAN01304	-91.20	9	-99.12	57.36	1.98	1.72	2	1	59.8	9/GR13	
CAN01403	-129.20	9	-89.75	52.02	4.68	0.80	148	1	61.8	9/GR12	10
CAN01404	-91.20	9	-84.82	52.42	3.10	2.05	152	1	60.4	9/GR13	10
CAN01405	-82.20	9	-84.00	52.39	2.84	2.29	172	1	60.3	9/GR14	10
CAN01504	-91.20	9	-72.66	53.77	3.57	1.67	156	1	60.2	9/GR13	10
CAN01505	-82.20	9	-71.77	53.79	3.30	1.89	162	1	60.1	9/GR14	10
CAN01605	-82.20	9	-61.50	49.55	2.65	1.40	143	1	60.3	9/GR14	10
CAN01606	-70.70	9	-61.30	49.55	2.40	1.65	148	1	60.2	10	
CHLCONT5	-106.20	9	-72.23	-35.57	2.60	0.80	55	1	59.4	9/GR17	
CHLPAC02	-106.20	9	-80.06	-30.06	1.36	0.80	69	1	59.2	9/GR17	
CLMAND01	-115.20	9	-74.72	5.93	3.85	1.63	114	1	64.9	9/GR5	
CLM00001	-103.20	9	-74.50	5.87	3.98	1.96	118	1	63.5	10	
EQACAND1	-115.20	9	-78.40	-1.61	1.37	0.95	75	1	64.0	9/GR5	
EQAGAND1	-115.20	9	-90.34	-0.62	0.90	0.81	89	1	61.3	9/GR5	
FLKANT01	-57.20	9	-44.54	-60.13	3.54	0.80	12	1	59.3	2	10
FLKFALKS	-31.00	9	-59.90	-51.64	0.80	0.80	90	1	58.1	2	
GRD00002	-42.20	9	-61.58	12.29	0.80	0.80	90	1	58.8		
HWA00002	-166.20	9	-165.79	23.42	4.20	0.80	160	1	58.8	9/GR1	10
HWA00003	-175.20	9	-166.10	23.42	4.25	0.80	159	1	58.8	9/GR2	10
MEX01NTE	-78.20	9	-105.81	26.01	2.89	2.08	155	1	60.5	1	
MEX01SUR	-69.20	9	-94.84	19.82	3.05	2.09	4	1	62.2	1	10
MEX02NTE	-136.20	9	-107.21	26.31	3.84	1.55	148	1	61.2	1	10
MEX02SUR	-127.20	9	-96.39	19.88	3.18	1.87	157	1	62.5	1	10
PAQPAC01	-106.20	9	-109.18	-27.53	0.80	0.80	90	1	56.2	9/GR17	
PRG00002	-99.20	9	-58.66	-23.32	1.45	1.04	76	1	60.2		
PRUAND02	-115.20	9	-74.69	-8.39	3.41	1.79	95	1	63.9	9/GR5	
PTRVIR01	-101.20	9	-65.85	18.12	0.80	0.80	90	1	60.5	1 6 9/GR20	
PTRVIR02	-110.20	9	-65.86	18.12	0.80	0.80	90	1	61.0	1 6 9/GR21	
SPMFRAN3	-53.20	9	-67.24	47.51	3.16	0.80	7	1	60.4	2 7	10
TRD00001	-84.70	9	-61.23	10.70	0.80	0.80	90	1	59.4		
URG00001	-71.70	9	-56.22	-32.52	1.02	0.89	11	1	60.0		
USAEH001	-61.70	9	-85.19	36.21	5.63	3.33	22	1	61.8	1 5 6	10
USAEH002	-101.20	9	-89.24	36.16	5.67	3.76	170	1	61.7	1 6 9/GR20	10
USAEH003	-110.20	9	-90.14	36.11	5.55	3.55	161	1	62.0	1 6 9/GR21	10
USAEH004	-119.20	9	-91.16	36.05	5.38	3.24	152	1	62.6	1 5 6	10
USAPSA02	-166.20	9	-117.80	40.58	4.03	0.82	135	1	63.2	9/GR1	
USAPSA03	-175.20	9	-118.27	40.12	3.62	0.80	136	1	65.0	9/GR2	
USAWH101	-148.20	9	-109.65	38.13	5.53	1.95	142	1	62.1	10	
USAWH102	-157.20	9	-111.41	38.57	5.51	1.54	138	1	63.2	10	
VENAND03	-115.20	9	-67.04	6.91	2.37	1.43	111	1	67.2	9/GR5	
VRG00001	-79.70	9	-64.37	18.48	0.80	0.80	90	1	58.3	4	



1	2	3	4		5		6	7	8	9	
ALS00002	-165.80	10	-149.63	58.52	3.81	1.23	171	2	59.7	9/GR1	10
ALS00003	-174.80	10	-150.95	58.54	3.77	1.11	167	2	60.0	9/GR2	10
ARGNORT4	-93.80	10	-63.96	-30.01	3.86	1.99	48	2	65.6	10	
ARGNORT5	-54.80	10	-62.85	-29.80	3.24	2.89	47	2	63.5	10	
ATNBEBAM1	-52.80	10	-66.44	14.87	1.83	0.80	39	2	61.0		
B CE311	-63.80	10	-40.60	-6.07	3.04	2.06	174	2	61.6	8/9/GR7	10
B CE312	-44.80	10	-40.26	-6.06	3.44	2.09	174	2	61.0	8/9/GR9	10
B CE411	-63.80	10	-50.97	-15.26	3.86	1.38	49	2	62.6	8/9/GR7	10
B CE412	-44.80	10	-50.71	-15.30	3.57	1.56	52	2	62.7	8/9/GR9	10
B CE511	-63.80	10	-53.11	-2.98	2.42	2.15	107	2	63.1	8/9/GR7	10
B NO611	-73.80	10	-59.60	-11.62	2.86	1.69	165	1	62.8	8/9/GR8	10
B NO711	-73.80	10	-60.70	-1.78	3.54	1.78	126	1	62.8	8/9/GR8	10
B NO811	-73.80	10	-68.75	-4.71	2.37	1.65	73	1	62.8	8/9/GR8	10
B SE911	-101.80	10	-45.99	-19.09	2.22	0.80	62	2	65.3	8	10
B SU111	-80.80	10	-51.10	-25.64	2.76	1.06	50	2	62.8	8/9/GR6	10
B SU112	-44.80	10	-50.76	-25.62	2.47	1.48	56	2	62.3	8/9/GR9	10
B SU211	-80.80	10	-44.51	-16.94	3.22	1.37	60	2	62.5	8/9/GR6	10
B SU212	-44.80	10	-43.99	-16.97	3.27	1.92	59	2	61.3	8/9/GR9	10
CAN01101	-137.80	10	-125.60	57.24	3.45	1.27	157	2	59.5	9/GR10	10
CAN01201	-137.80	10	-111.92	55.89	3.33	0.98	151	2	59.6	9/GR10	10
CAN01202	-72.30	10	-107.64	55.62	2.75	1.11	32	2	59.6		
CAN01203	-128.80	10	-111.43	55.56	3.07	1.15	151	2	59.5	9/GR12	10
CAN01303	-128.80	10	-102.39	57.12	3.54	0.92	154	2	60.0	9/GR12	10
CAN01304	-90.80	10	-99.00	57.33	1.96	1.73	1	2	59.8	9/GR13	10
CAN01403	-128.80	10	-89.70	52.02	4.67	0.80	148	2	61.8	9/GR12	10
CAN01404	-90.80	10	-84.78	52.41	3.09	2.06	153	2	60.4	9/GR13	10
CAN01405	-81.80	10	-84.02	52.34	2.82	2.30	172	2	60.3	9/GR14	10
CAN01504	-90.80	10	-72.68	53.78	3.57	1.67	157	2	60.2	9/GR13	10
CAN01505	-81.80	10	-71.76	53.76	3.30	1.89	162	2	60.1	9/GR14	10
CAN01605	-81.80	10	-61.54	49.50	2.66	1.39	144	2	60.3	9/GR14	10
CAN01606	-70.30	10	-61.32	49.51	2.41	1.65	148	2	60.2	10	
CHLCONT4	-105.80	10	-69.59	-23.20	2.21	0.80	68	2	59.1	9/GR16	10
CHLCONT6	-105.80	10	-73.52	-55.52	3.65	1.31	39	2	59.6	9/GR16	10
CRBBAH01	-92.30	10	-76.09	24.13	1.83	0.80	141	1	61.7	9/GR18	10
CRBBER01	-92.30	10	-64.76	32.13	0.80	0.80	90	1	56.7	9/GR18	10
CRBBLZ01	-92.30	10	-88.61	17.26	0.80	0.80	90	1	58.6	9/GR18	10
CRBEC001	-92.30	10	-60.07	8.26	4.20	0.86	115	1	64.2	9/GR18	10
CRBJMC01	-92.30	10	-79.45	17.97	0.99	0.80	151	1	61.1	9/GR18	10
CTR00201	-130.80	10	-84.33	9.67	0.82	0.80	119	2	65.6		
EQAC0001	-94.80	10	-78.31	-1.52	1.48	1.15	65	1	63.0	9/GR19	10
EQAG0001	-94.80	10	-90.36	-0.57	0.94	0.89	99	1	61.0	9/GR19	10
GUY00302	-33.80	10	-59.07	4.77	1.43	0.85	91	2	63.5		
HNDIFRB2	-107.30	10	-86.23	15.16	1.14	0.85	8	1	63.4		
HTI00002	-83.30	10	-73.28	18.96	0.82	0.80	11	2	60.9		
HWA00002	-165.80	10	-165.79	23.32	4.20	0.80	160	2	58.8	9/GR1	10
HWA00003	-174.80	10	-166.10	23.42	4.25	0.80	159	2	58.8	9/GR2	10
MEX01NTE	-77.80	10	-105.80	25.99	2.88	2.07	155	2	60.5	1	
MEX02NTE	-135.80	10	-107.36	26.32	3.80	1.57	149	2	61.2	1	10
MEX02SUR	-126.80	10	-96.39	19.88	3.19	1.87	158	2	62.5	1	10
PRU00004	-85.80	10	-74.19	-8.39	3.74	2.45	112	2	62.8	10	
PTRVIR01	-100.80	10	-65.85	18.12	0.80	0.80	90	2	60.6	1 6 9/GR20	
PTRVIR02	-109.80	10	-65.85	18.12	0.80	0.80	90	2	61.1	1 6 9/GR21	
TCA00001	-115.80	10	-71.79	21.53	0.80	0.80	90	2	60.4		
USAEH001	-61.30	10	-85.16	36.21	5.63	3.32	22	2	61.8	1 5 6	10
USAEH002	-100.80	10	-89.28	36.16	5.65	3.78	170	2	61.7	1 6 9/GR20	10
USAEH003	-109.80	10	-90.12	36.11	5.55	3.56	161	2	62.1	1 6 9/GR21	10
USAEH004	-118.80	10	-91.16	36.05	5.38	3.24	153	2	62.6	1 5 6	10
USAPSA02	-165.80	10	-117.79	40.58	4.04	0.82	135	2	63.2	9/GR1	
USAPSA03	-174.80	10	-118.20	40.15	3.63	0.80	136	2	64.9	9/GR2	
USAWH101	-147.80	10	-109.70	38.13	5.52	1.96	142	2	62.1	10	
USAWH102	-156.80	10	-111.40	38.57	5.51	1.55	138	2	63.2	10	
VCT00001	-79.30	10	-61.18	13.23	0.80	0.80	90	2	58.4		
VEN11VEN	-103.80	10	-66.79	6.90	2.50	1.77	122	2	65.1	10	

## 12 369.80 MHz (11)

1	2	3	4		5		6	7	8	9	
ALS00002	-166.20	11	-149.66	58.37	3.76	1.24	170	1	59.8	9/GR1	10
ALS00003	-175.20	11	-150.98	58.53	3.77	1.11	167	1	60.0	9/GR2	10
ARGINSU4	-94.20	11	-52.98	-59.81	3.40	0.80	19	1	59.9	9/GR3	
ARGINSU5	-55.20	11	-44.17	-59.91	3.77	0.80	13	1	59.3	9/GR4	10
ARGSUR04	-94.20	11	-65.04	-43.33	3.32	1.50	40	1	60.7	9/GR3	10
ARGSUR05	-55.20	11	-63.68	-43.01	2.54	2.38	152	1	60.1	9/GR4	10
ATGSJN01	-79.70	11	-61.79	17.07	0.80	0.80	90	1	58.4		
B CE311	-64.20	11	-40.60	-6.07	3.04	2.06	174	1	61.6	8 9/GR7	
B CE312	-45.20	11	-40.27	-6.06	3.44	2.09	174	1	61.0	8 9/GR9	10
B CE411	-64.20	11	-50.97	-15.27	3.86	1.38	49	1	62.6	8 9/GR7	10
B CE412	-45.20	11	-50.71	-15.30	3.57	1.56	52	1	62.7	8 9/GR9	10
B CE511	-64.20	11	-53.10	-2.90	2.44	2.13	104	1	63.1	8 9/GR7	10
B NO611	-74.20	11	-59.60	-11.62	2.85	1.69	165	2	62.9	8 9/GR8	10
B NO711	-74.20	11	-60.70	-1.78	3.54	1.78	126	2	62.8	8 9/GR8	10
B NO811	-74.20	11	-68.76	-4.71	2.37	1.65	73	2	62.8	8 9/GR8	
B SU111	-81.20	11	-51.12	-25.63	2.76	1.05	50	1	62.9	8 9/GR6	10
B SU112	-45.20	11	-50.75	-25.62	2.47	1.48	56	1	62.3	8 9/GR9	
B SU211	-81.20	11	-44.51	-16.95	3.22	1.36	60	1	62.5	8 9/GR6	10
B SU212	-45.20	11	-44.00	-16.87	3.20	1.96	58	1	61.3	8 9/GR9	
BERBERMU	-96.20	11	-64.77	32.32	0.80	0.80	90	2	56.8		
BOLAND01	-115.20	11	-65.04	-16.76	2.49	1.27	76	1	67.9	9/GR5	
BOL00001	-87.20	11	-64.61	-16.71	2.52	2.19	85	1	63.8	10	
BRB00001	-92.70	11	-59.85	12.93	0.80	0.80	90	2	59.1		
CAN01101	-138.20	11	-125.63	57.24	3.45	1.27	157	1	59.5	9/GR10	10
CAN01201	-138.20	11	-112.04	55.95	3.35	0.97	151	1	59.6	9/GR10	10
CAN01202	-72.70	11	-107.70	55.63	2.74	1.12	32	1	59.6		
CAN01203	-129.20	11	-111.48	55.61	3.08	1.15	151	1	59.5	9/GR12	10
CAN01303	-129.20	11	-102.42	57.12	3.54	0.91	154	1	60.1	9/GR12	10
CAN01304	-91.20	11	-99.12	57.36	1.98	1.72	2	1	59.8	9/GR13	
CAN01403	-129.20	11	-89.75	52.02	4.68	0.80	148	1	61.8	9/GR12	10
CAN01404	-91.20	11	-84.82	52.42	3.10	2.05	152	1	60.4	9/GR13	10
CAN01405	-82.20	11	-84.00	52.39	2.84	2.29	172	1	60.3	9/GR14	10
CAN01504	-91.20	11	-72.66	53.77	3.57	1.67	156	1	60.2	9/GR13	10
CAN01505	-82.20	11	-71.77	53.79	3.30	1.89	162	1	60.1	9/GR14	10
CAN01605	-82.20	11	-61.50	49.55	2.65	1.40	143	1	60.3	9/GR14	10
CAN01606	-70.70	11	-61.30	49.55	2.40	1.65	148	1	60.2	10	
CHLCONT5	-106.20	11	-72.23	-35.57	2.60	0.80	55	1	59.4	9/GR17	
CHLPAC02	-106.20	11	-80.06	-30.06	1.36	0.80	69	1	59.2	9/GR17	
CLMAND01	-115.20	11	-74.72	5.93	3.85	1.63	114	1	65.0	9/GR5	
CLM00001	-103.20	11	-74.50	5.87	3.98	1.96	118	1	63.6	10	
CUB00001	-89.20	11	-79.81	21.62	2.24	0.80	168	1	61.1		
EQACAND1	-115.20	11	-78.40	-1.61	1.37	0.95	75	1	64.1	9/GR5	
EQAGAND1	-115.20	11	-90.34	-0.62	0.90	0.81	89	1	61.3	9/GR5	
GRD00002	-42.20	11	-61.58	12.29	0.80	0.80	90	1	58.8		
GRD00059	-57.20	11	-61.58	12.29	0.80	0.80	90	1	58.5		
GRLDNK01	-53.20	11	-44.89	66.56	2.70	0.82	173	1	60.0	2	10
GUY00201	-84.70	11	-59.19	4.78	1.44	0.85	95	1	63.5		
HWA00002	-166.20	11	-165.79	23.42	4.20	0.80	160	1	58.8	9/GR1	10
HWA00003	-175.20	11	-166.10	23.42	4.25	0.80	159	1	58.8	9/GR2	10
MEX01NTE	-78.20	11	-105.81	26.01	2.89	2.08	155	1	60.5	1	
MEX01SUR	-69.20	11	-94.84	19.82	3.05	2.09	4	1	62.3	1	10
MEX02NTE	-136.20	11	-107.21	26.31	3.84	1.55	148	1	61.2	1	10
MEX02SUR	-127.20	11	-96.39	19.88	3.18	1.87	157	1	62.6	1	10
PAQPAC01	-106.20	11	-109.18	-27.53	0.80	0.80	90	1	56.2	9/GR17	
PRG00002	-99.20	11	-58.66	-23.32	1.45	1.04	76	1	60.2		
PRUAND02	-115.20	11	-74.69	-8.39	3.41	1.79	95	1	64.0	9/GR5	
PTRVIR01	-101.20	11	-65.85	18.12	0.80	0.80	90	1	60.6	1 6 9/GR20	
PTRVIR02	-110.20	11	-65.86	18.12	0.80	0.80	90	1	61.0	1 6 9/GR21	
URG00001	-71.70	11	-56.22	-32.52	1.02	0.89	11	1	60.0		
USAEH001	-61.70	11	-85.19	36.21	5.63	3.33	22	1	61.8	1 5 6	10
USAEH002	-101.20	11	-89.24	36.16	5.67	3.76	170	1	61.7	1 6 9/GR20	10
USAEH003	-110.20	11	-90.14	36.11	5.55	3.55	161	1	62.1	1 6 9/GR21	10
USAEH004	-119.20	11	-91.16	36.05	5.38	3.24	152	1	62.6	1 5 6	10
USAPSA02	-166.20	11	-117.80	40.58	4.03	0.82	135	1	63.3	9/GR1	
USAPSA03	-175.20	11	-118.27	40.12	3.62	0.80	136	1	65.0	9/GR2	
USAWH101	-148.20	11	-109.65	38.13	5.53	1.95	142	1	62.1	10	
USAWH102	-157.20	11	-111.41	38.57	5.51	1.54	138	1	63.2	10	
VENAND03	-115.20	11	-67.04	6.91	2.37	1.43	111	1	67.3	9/GR5	

1	2	3	4		5		6	7	8	9	
ALS00002	-165.80	12	-149.63	58.52	3.81	1.23	171	2	59.8	9/GR1	10
ALS00003	-174.80	12	-150.95	58.54	3.77	1.11	167	2	60.0	9/GR2	10
ARGNORT4	-93.80	12	-63.96	-30.01	3.86	1.99	48	2	65.7	10	
ARGNORT5	-54.80	12	-62.85	-29.80	3.24	2.89	47	2	63.5	10	
B CE311	-63.80	12	-40.60	-6.07	3.04	2.06	174	2	61.6	8 9/GR7	10
B CE312	-44.80	12	-40.26	-6.06	3.44	2.09	174	2	61.0	8 9/GR9	10
B CE411	-63.80	12	-50.97	-15.26	3.86	1.38	49	2	62.6	8 9/GR7	10
B CE412	-44.80	12	-50.71	-15.30	3.57	1.56	52	2	62.8	8 9/GR9	10
B CE511	-63.80	12	-53.11	-2.98	2.42	2.15	107	2	63.1	8 9/GR7	10
B NO611	-73.80	12	-59.60	-11.62	2.86	1.69	165	1	62.9	8 9/GR8	10
B NO711	-73.80	12	-60.70	-1.78	3.54	1.78	126	1	62.8	8 9/GR8	10
B NO811	-73.80	12	-68.75	-4.71	2.37	1.65	73	1	62.8	8 9/GR8	10
B SE911	-101.80	12	-45.99	-19.09	2.22	0.80	62	2	65.3	8	10
B SU111	-80.80	12	-51.10	-25.64	2.76	1.06	50	2	62.9	8 9/GR6	10
B SU112	-44.80	12	-50.76	-25.62	2.47	1.48	56	2	62.3	8 9/GR9	10
B SU211	-80.80	12	-44.51	-16.94	3.22	1.37	60	2	62.5	8 9/GR6	10
B SU212	-44.80	12	-43.99	-16.97	3.27	1.92	59	2	61.3	8 9/GR9	10
CAN01101	-137.80	12	-125.60	57.24	3.45	1.27	157	2	59.5	9/GR10	10
CAN01201	-137.80	12	-111.92	55.89	3.33	0.98	151	2	59.6	9/GR10	10
CAN01202	-72.30	12	-107.64	55.62	2.75	1.11	32	2	59.6		
CAN01203	-128.80	12	-111.43	55.56	3.07	1.15	151	2	59.5	9/GR12	10
CAN01303	-128.80	12	-102.39	57.12	3.54	0.92	154	2	60.1	9/GR12	10
CAN01304	-90.80	12	-99.00	57.33	1.96	1.73	1	2	59.8	9/GR13	10
CAN01403	-128.80	12	-89.70	52.02	4.67	0.80	148	2	61.8	9/GR12	10
CAN01404	-90.80	12	-84.78	52.41	3.09	2.06	153	2	60.4	9/GR13	10
CAN01405	-81.80	12	-84.02	52.34	2.82	2.30	172	2	60.3	9/GR14	10
CAN01504	-90.80	12	-72.68	53.78	3.57	1.67	157	2	60.2	9/GR13	10
CAN01505	-81.80	12	-71.76	53.76	3.30	1.89	162	2	60.2	9/GR14	10
CAN01605	-81.80	12	-61.54	49.50	2.66	1.39	144	2	60.3	9/GR14	10
CAN01606	-70.30	12	-61.32	49.51	2.41	1.65	148	2	60.2	10	
CHLCONT4	-105.80	12	-69.59	-23.20	2.21	0.80	68	2	59.1	9/GR16	10
CHLCONT6	-105.80	12	-73.52	-55.52	3.65	1.31	39	2	59.6	9/GR16	10
CRBBAH01	-92.30	12	-76.09	24.13	1.83	0.80	141	1	61.7	9/GR18	10
CRBBER01	-92.30	12	-64.76	32.13	0.80	0.80	90	1	56.8	9/GR18	10
CRBBLZ01	-92.30	12	-88.61	17.26	0.80	0.80	90	1	58.7	9/GR18	10
CRBEC001	-92.30	12	-60.07	8.26	4.20	0.86	115	1	64.3	9/GR18	10
CRBJMC01	-92.30	12	-79.45	17.97	0.99	0.80	151	1	61.1	9/GR18	10
CYM00001	-115.80	12	-80.58	19.57	0.80	0.80	90	2	59.6		
DOMIFRB2	-83.30	12	-70.51	18.79	0.98	0.80	167	2	61.1		
EQAC0001	-94.80	12	-78.31	-1.52	1.48	1.15	65	1	63.0	9/GR19	10
EQAG0001	-94.80	12	-90.36	-0.57	0.94	0.89	99	1	61.0	9/GR19	10
GUFMGG02	-52.80	12	-56.42	8.47	4.16	0.81	123	2	62.7	2 7	10
HWA00002	-165.80	12	-165.79	23.32	4.20	0.80	160	2	58.8	9/GR1	10
HWA00003	-174.80	12	-166.10	23.42	4.25	0.80	159	2	58.8	9/GR2	10
JMC00005	-33.80	12	-77.27	18.12	0.80	0.80	90	2	60.6		
LCAIFRB1	-79.30	12	-61.15	13.90	0.80	0.80	90	2	58.4		
MEX01NTE	-77.80	12	-105.80	25.99	2.88	2.07	155	2	60.5	1	
MEX02NTE	-135.80	12	-107.36	26.32	3.80	1.57	149	2	61.2	1	10
MEX02SUR	-126.80	12	-96.39	19.88	3.19	1.87	158	2	62.5	1	10
PRU00004	-85.80	12	-74.19	-8.39	3.74	2.45	112	2	62.9	10	
PTRVIR01	-100.80	12	-65.85	18.12	0.80	0.80	90	2	60.6	1 6 9/GR20	
PTRVIR02	-109.80	12	-65.85	18.12	0.80	0.80	90	2	61.1	1 6 9/GR21	
SLVIFRB2	-107.30	12	-88.91	13.59	0.80	0.80	90	1	61.7		
USAEH001	-61.30	12	-85.16	36.21	5.63	3.32	22	2	61.9	1 5 6	10
USAEH002	-100.80	12	-89.28	36.16	5.65	3.78	170	2	61.7	1 6 9/GR20	10
USAEH003	-109.80	12	-90.12	36.11	5.55	3.56	161	2	62.1	1 6 9/GR21	10
USAEH004	-118.80	12	-91.16	36.05	5.38	3.24	153	2	62.6	1 5 6	10
USAPSA02	-165.80	12	-117.79	40.58	4.04	0.82	135	2	63.3	9/GR1	10
USAPSA03	-174.80	12	-118.20	40.15	3.63	0.80	136	2	65.0	9/GR2	10
USAWH101	-147.80	12	-109.70	38.13	5.52	1.96	142	2	62.1	10	
USAWH102	-156.80	12	-111.40	38.57	5.51	1.55	138	2	63.2	10	
VEN11VEN	-103.80	12	-66.79	6.90	2.50	1.77	122	2	65.2	10	

12 398.96 MHz (13)

1	2	3	4		5		6	7	8	9	
ALS00002	-166.20	13	-149.66	58.37	3.76	1.24	170	1	59.7	9/GR1	10
ALS00003	-175.20	13	-150.98	58.53	3.77	1.11	167	1	60.0	9/GR2	10
ARGINSU4	-94.20	13	-52.98	-59.81	3.40	0.80	19	1	59.9	9/GR3	
ARGSUR04	-94.20	13	-65.04	-43.33	3.32	1.50	40	1	60.7	9/GR3	10
B CE311	-64.20	13	-40.60	-6.07	3.04	2.06	174	1	61.6	8 9/GR7	10
B CE312	-45.20	13	-40.27	-6.06	3.44	2.09	174	1	61.0	8 9/GR9	10
B CE411	-64.20	13	-50.97	-15.27	3.86	1.38	49	1	62.6	8 9/GR7	10
B CE412	-45.20	13	-50.71	-15.30	3.57	1.56	52	1	62.7	8 9/GR9	10
B CE511	-64.20	13	-53.10	-2.90	2.44	2.13	104	1	63.0	8 9/GR7	10
B NO611	-74.20	13	-59.60	-11.62	2.85	1.69	165	2	62.8	8 9/GR8	10
B NO711	-74.20	13	-60.70	-1.78	3.54	1.78	126	2	62.8	8 9/GR8	10
B NO811	-74.20	13	-68.76	-4.71	2.37	1.65	73	2	62.8	8 9/GR8	10
B SU111	-81.20	13	-51.12	-25.63	2.76	1.05	50	1	62.8	8 9/GR6	10
B SU112	-45.20	13	-50.75	-25.62	2.47	1.48	56	1	62.2	8 9/GR9	
B SU211	-81.20	13	-44.51	-16.95	3.22	1.36	60	1	62.5	8 9/GR6	10
B SU212	-45.20	13	-44.00	-16.87	3.20	1.96	58	1	61.3	8 9/GR9	
BAHIFRB1	-87.20	13	-76.06	24.16	1.81	0.80	142	1	61.6		
BERBERMU	-96.20	13	-64.77	32.32	0.80	0.80	90	2	56.8		
BERBER02	-31.00	13	-64.77	32.32	0.80	0.80	90	1	56.9	2	10
BOLAND01	-115.20	13	-65.04	-16.76	2.49	1.27	76	1	67.9	9/GR5	
CAN01101	-138.20	13	-125.63	57.24	3.45	1.27	157	1	59.5	9/GR10	10
CAN01201	-138.20	13	-112.04	55.95	3.35	0.97	151	1	59.6	9/GR10	10
CAN01202	-72.70	13	-107.70	55.63	2.74	1.12	32	1	59.6		
CAN01203	-129.20	13	-111.48	55.61	3.08	1.15	151	1	59.5	9/GR12	10
CAN01303	-129.20	13	-102.42	57.12	3.54	0.91	154	1	60.0	9/GR12	10
CAN01304	-91.20	13	-99.12	57.36	1.98	1.72	2	1	59.8	9/GR13	
CAN01403	-129.20	13	-89.75	52.02	4.68	0.80	148	1	61.8	9/GR12	10
CAN01404	-91.20	13	-84.82	52.42	3.10	2.05	152	1	60.4	9/GR13	10
CAN01405	-82.20	13	-84.00	52.39	2.84	2.29	172	1	60.3	9/GR14	10
CAN01504	-91.20	13	-72.66	53.77	3.57	1.67	156	1	60.2	9/GR13	10
CAN01505	-82.20	13	-71.77	53.79	3.30	1.89	162	1	60.1	9/GR14	10
CAN01605	-82.20	13	-61.50	49.55	2.65	1.40	143	1	60.3	9/GR14	10
CAN01606	-70.70	13	-61.30	49.55	2.40	1.65	148	1	60.2	10	
CHLCONT5	-106.20	13	-72.23	-35.57	2.60	0.80	55	1	59.4	9/GR17	
CHLPAC02	-106.20	13	-80.06	-30.06	1.36	0.80	69	1	59.2	9/GR17	
CLMAND01	-115.20	13	-74.72	5.93	3.85	1.63	114	1	64.9	9/GR5	
CLM00001	-103.20	13	-74.50	5.87	3.98	1.96	118	1	63.5	10	
EQACAND1	-115.20	13	-78.40	-1.61	1.37	0.95	75	1	64.0	9/GR5	
EQAGAND1	-115.20	13	-90.34	-0.62	0.90	0.81	89	1	61.3	9/GR5	
FLKANT01	-57.20	13	-44.54	-60.13	3.54	0.80	12	1	59.3	2	10
FLKFALKS	-31.00	13	-59.90	-51.64	0.80	0.80	90	1	58.1	2	
GRD00002	-42.20	13	-61.58	12.29	0.80	0.80	90	1	58.8		
HWA00002	-166.20	13	-165.79	23.42	4.20	0.80	160	1	58.8	9/GR1	10
HWA00003	-175.20	13	-166.10	23.42	4.25	0.80	159	1	58.8	9/GR2	10
MEX01NTE	-78.20	13	-105.81	26.01	2.89	2.08	155	1	60.5	1	
MEX01SUR	-69.20	13	-94.84	19.82	3.05	2.09	4	1	62.2	1	10
MEX02NTE	-136.20	13	-107.21	26.31	3.84	1.55	148	1	61.2	1	10
MEX02SUR	-127.20	13	-96.39	19.88	3.18	1.87	157	1	62.5	1	10
PAQPAC01	-106.20	13	-109.18	-27.53	0.80	0.80	90	1	56.2	9/GR17	
PRG00002	-99.20	13	-58.66	-23.32	1.45	1.04	76	1	60.2		
PRUAND02	-115.20	13	-74.69	-8.39	3.41	1.79	95	1	63.9	9/GR5	
PTRVIR01	-101.20	13	-65.85	18.12	0.80	0.80	90	1	60.5	1 6 9/GR20	
PTRVIR02	-110.20	13	-65.86	18.12	0.80	0.80	90	1	61.0	1 6 9/GR21	
SPMFRAN3	-53.20	13	-67.24	47.51	3.16	0.80	7	1	60.4	2 7	10
TRD00001	-84.70	13	-61.23	10.70	0.80	0.80	90	1	59.4		
URG00001	-71.70	13	-56.22	-32.52	1.02	0.89	11	1	60.0		
USAEH001	-61.70	13	-85.19	36.21	5.63	3.33	22	1	61.8	1 5 6	10
USAEH002	-101.20	13	-89.24	36.16	5.67	3.76	170	1	61.7	1 6 9/GR20	10
USAEH003	-110.20	13	-90.14	36.11	5.55	3.55	161	1	62.0	1 6 9/GR21	10
USAEH004	-119.20	13	-91.16	36.05	5.38	3.24	152	1	62.6	1 5 6	10
USAPSA02	-166.20	13	-117.80	40.58	4.03	0.82	135	1	63.2	9/GR1	
USAPSA03	-175.20	13	-118.27	40.12	3.62	0.80	136	1	65.0	9/GR2	
USAWH101	-148.20	13	-109.65	38.13	5.53	1.95	142	1	62.1	10	
USAWH102	-157.20	13	-111.41	38.57	5.51	1.54	138	1	63.2	10	
VENAND03	-115.20	13	-67.04	6.91	2.37	1.43	111	1	67.2	9/GR5	
VRG00001	-79.70	13	-64.37	18.48	0.80	0.80	90	1	58.3	4	

1	2	3	4		5		6	7	8	9	
ALS00002	-165.80	14	-149.63	58.52	3.81	1.23	171	2	59.7	9/GR1	10
ALS00003	-174.80	14	-150.95	58.54	3.77	1.11	167	2	60.0	9/GR2	10
ARGNORT4	-93.80	14	-63.96	-30.01	3.86	1.99	48	2	65.6	10	
ARGNORT5	-54.80	14	-62.85	-29.80	3.24	2.89	47	2	63.5	10	
ATNBEAM1	-52.80	14	-66.44	14.87	1.83	0.80	39	2	61.0		
B CE311	-63.80	14	-40.60	-6.07	3.04	2.06	174	2	61.6	8 9/GR7	
B CE312	-44.80	14	-40.26	-6.06	3.44	2.09	174	2	61.0	8 9/GR9	10
B CE411	-63.80	14	-50.97	-15.26	3.86	1.38	49	2	62.6	8 9/GR7	10
B CE412	-44.80	14	-50.71	-15.30	3.57	1.56	52	2	62.7	8 9/GR9	10
B CE511	-63.80	14	-53.11	-2.98	2.42	2.15	107	2	63.1	8 9/GR7	10
B NO611	-73.80	14	-59.60	-11.62	2.86	1.69	165	1	62.8	8 9/GR8	10
B NO711	-73.80	14	-60.70	-1.78	3.54	1.78	126	1	62.8	8 9/GR8	10
B NO811	-73.80	14	-68.75	-4.71	2.37	1.65	73	1	62.8	8 9/GR8	10
B SE911	-101.80	14	-45.99	-19.09	2.22	0.80	62	2	65.3	8	10
B SU111	-80.80	14	-51.10	-25.64	2.76	1.06	50	2	62.8	8 9/GR6	10
B SU112	-44.80	14	-50.76	-25.62	2.47	1.48	56	2	62.3	8 9/GR9	
B SU211	-80.80	14	-44.51	-16.94	3.22	1.37	60	2	62.5	8 9/GR6	10
B SU212	-44.80	14	-43.99	-16.97	3.27	1.92	59	2	61.3	8 9/GR9	
CAN01101	-137.80	14	-125.60	57.24	3.45	1.27	157	2	59.5	9/GR10	10
CAN01201	-137.80	14	-111.92	55.89	3.33	0.98	151	2	59.6	9/GR10	10
CAN01202	-72.30	14	-107.64	55.62	2.75	1.11	32	2	59.6		
CAN01203	-128.80	14	-111.43	55.56	3.07	1.15	151	2	59.5	9/GR12	10
CAN01303	-128.80	14	-102.39	57.12	3.54	0.92	154	2	60.0	9/GR12	10
CAN01304	-90.80	14	-99.00	57.33	1.96	1.73	1	2	59.8	9/GR13	
CAN01403	-128.80	14	-89.70	52.02	4.67	0.80	148	2	61.8	9/GR12	
CAN01404	-90.80	14	-84.78	52.41	3.09	2.06	153	2	60.4	9/GR13	10
CAN01405	-81.80	14	-84.02	52.34	2.82	2.30	172	2	60.3	9/GR14	10
CAN01504	-90.80	14	-72.68	53.78	3.57	1.67	157	2	60.2	9/GR13	10
CAN01505	-81.80	14	-71.76	53.76	3.30	1.89	162	2	60.1	9/GR14	10
CAN01605	-81.80	14	-61.54	49.50	2.66	1.39	144	2	60.3	9/GR14	10
CAN01606	-70.30	14	-61.32	49.51	2.41	1.65	148	2	60.2	10	
CHLCONT4	-105.80	14	-69.59	-23.20	2.21	0.80	68	2	59.1	9/GR16	
CHLCONT6	-105.80	14	-73.52	-55.52	3.65	1.31	39	2	59.6	9/GR16	
CRBBAH01	-92.30	14	-76.09	24.13	1.83	0.80	141	1	61.7	9/GR18	
CRBBER01	-92.30	14	-64.76	32.13	0.80	0.80	90	1	56.7	9/GR18	
CRBBLZ01	-92.30	14	-88.61	17.26	0.80	0.80	90	1	58.6	9/GR18	
CRBEC001	-92.30	14	-60.07	8.26	4.20	0.86	115	1	64.2	9/GR18	10
CRBJMC01	-92.30	14	-79.45	17.97	0.99	0.80	151	1	61.1	9/GR18	
CTR00201	-130.80	14	-84.33	9.67	0.82	0.80	119	2	65.6		
EQAC0001	-94.80	14	-78.31	-1.52	1.48	1.15	65	1	63.0	9/GR19	
EQAG0001	-94.80	14	-90.36	-0.57	0.94	0.89	99	1	61.0	9/GR19	
GU0Y0302	-33.80	14	-59.07	4.77	1.43	0.85	91	2	63.5		
HNDIFRB2	-107.30	14	-86.23	15.16	1.14	0.85	8	1	63.4		
HTI00002	-83.30	14	-73.28	18.96	0.82	0.80	11	2	60.9		
HWA00002	-165.80	14	-165.79	23.32	4.20	0.80	160	2	58.8	9/GR1	10
HWA00003	-174.80	14	-166.10	23.42	4.25	0.80	159	2	58.8	9/GR2	10
MEX01NTE	-77.80	14	-105.80	25.99	2.88	2.07	155	2	60.5	1	
MEX02NTE	-135.80	14	-107.36	26.32	3.80	1.57	149	2	61.2	1	10
MEX02SUR	-126.80	14	-96.39	19.88	3.19	1.87	158	2	62.5	1	10
PRU00004	-85.80	14	-74.19	-8.39	3.74	2.45	112	2	62.8	10	
PTRVIR01	-100.80	14	-65.85	18.12	0.80	0.80	90	2	60.6	1 6 9/GR20	
PTRVIR02	-109.80	14	-65.85	18.12	0.80	0.80	90	2	61.1	1 6 9/GR21	
TCA00001	-115.80	14	-71.79	21.53	0.80	0.80	90	2	60.4		
USAEH001	-61.30	14	-85.16	36.21	5.63	3.32	22	2	61.8	1 5 6	10
USAEH002	-100.80	14	-89.28	36.16	5.65	3.78	170	2	61.7	1 6 9/GR20	10
USAEH003	-109.80	14	-90.12	36.11	5.55	3.56	161	2	62.1	1 6 9/GR21	10
USAEH004	-118.80	14	-91.16	36.05	5.38	3.24	153	2	62.6	1 5 6	10
USAPSA02	-165.80	14	-117.79	40.58	4.04	0.82	135	2	63.2	9/GR1	
USAPSA03	-174.80	14	-118.20	40.15	3.63	0.80	136	2	64.9	9/GR2	
USAWH101	-147.80	14	-109.70	38.13	5.52	1.96	142	2	62.1	10	
USAWH102	-156.80	14	-111.40	38.57	5.51	1.55	138	2	63.2	10	
VCT00001	-79.30	14	-61.18	13.23	0.80	0.80	90	2	58.4		
VEN11VEN	-103.80	14	-66.79	6.90	2.50	1.77	122	2	65.1	10	

12 428.12 MHz (15)

1	2	3	4	5	6	7	8	9			
ALS00002	-166.20	15	-149.66	58.37	3.76	1.24	170	1	59.8	9/GR1	10
ALS00003	-175.20	15	-150.98	58.53	3.77	1.11	167	1	60.0	9/GR2	10
ARGINSU4	-94.20	15	-52.98	-59.81	3.40	0.80	19	1	59.9	9/GR3	
ARGINSU5	-55.20	15	-44.17	-59.91	3.77	0.80	13	1	59.3	9/GR4	10
ARGSUR04	-94.20	15	-65.04	-43.33	3.32	1.50	40	1	60.7	9/GR3	10
ARGSUR05	-55.20	15	-63.68	-43.01	2.54	2.38	152	1	60.1	9/GR4	10
ATGSJN01	-79.70	15	-61.79	17.07	0.80	0.80	90	1	58.4		
B CE311	-64.20	15	-40.60	-6.07	3.04	2.06	174	1	61.6	8 9/GR7	
B CE312	-45.20	15	-40.27	-6.06	3.44	2.09	174	1	61.0	8 9/GR9	10
B CE411	-64.20	15	-50.97	-15.27	3.86	1.38	49	1	62.6	8 9/GR7	10
B CE412	-45.20	15	-50.71	-15.30	3.57	1.56	52	1	62.7	8 9/GR9	10
B CE511	-64.20	15	-53.10	-2.90	2.44	2.13	104	1	63.1	8 9/GR7	10
B NO611	-74.20	15	-59.60	-11.62	2.85	1.69	165	2	62.9	8 9/GR8	10
B NO711	-74.20	15	-60.70	-1.78	3.54	1.78	126	2	62.8	8 9/GR8	10
B NO811	-74.20	15	-68.76	-4.71	2.37	1.65	73	2	62.8	8 9/GR8	
B SU111	-81.20	15	-51.12	-25.63	2.76	1.05	50	1	62.9	8 9/GR6	10
B SU112	-45.20	15	-50.75	-25.62	2.47	1.48	56	1	62.3	8 9/GR9	
B SU211	-81.20	15	-44.51	-16.95	3.22	1.36	60	1	62.5	8 9/GR6	10
B SU212	-45.20	15	-44.00	-16.87	3.20	1.96	58	1	61.3	8 9/GR9	
BERBERMU	-96.20	15	-64.77	32.32	0.80	0.80	90	2	56.8		
BOLAND01	-115.20	15	-65.04	-16.76	2.49	1.27	76	1	67.9	9/GR5	
BOL00001	-87.20	15	-64.61	-16.71	2.52	2.19	85	1	63.8	10	
BRB00001	-92.70	15	-59.85	12.93	0.80	0.80	90	2	59.1		
CAN01101	-138.20	15	-125.63	57.24	3.45	1.27	157	1	59.5	9/GR10	10
CAN01201	-138.20	15	-112.04	55.95	3.35	0.97	151	1	59.6	9/GR10	10
CAN01202	-72.70	15	-107.70	55.63	2.74	1.12	32	1	59.6		
CAN01203	-129.20	15	-111.48	55.61	3.08	1.15	151	1	59.5	9/GR12	10
CAN01303	-129.20	15	-102.42	57.12	3.54	0.91	154	1	60.1	9/GR12	10
CAN01304	-91.20	15	-99.12	57.36	1.98	1.72	2	1	59.8	9/GR13	
CAN01403	-129.20	15	-89.75	52.02	4.68	0.80	148	1	61.8	9/GR12	10
CAN01404	-91.20	15	-84.82	52.42	3.10	2.05	152	1	60.4	9/GR13	10
CAN01405	-82.20	15	-84.00	52.39	2.84	2.29	172	1	60.3	9/GR14	10
CAN01504	-91.20	15	-72.66	53.77	3.57	1.67	156	1	60.2	9/GR13	10
CAN01505	-82.20	15	-71.77	53.79	3.30	1.89	162	1	60.1	9/GR14	10
CAN01605	-82.20	15	-61.50	49.55	2.65	1.40	143	1	60.3	9/GR14	10
CAN01606	-70.70	15	-61.30	49.55	2.40	1.65	148	1	60.2	10	
CHLCONT5	-106.20	15	-72.23	-35.57	2.60	0.80	55	1	59.4	9/GR17	
CHLPAC02	-106.20	15	-80.06	-30.06	1.36	0.80	69	1	59.2	9/GR17	
CLMAND01	-115.20	15	-74.72	5.93	3.85	1.63	114	1	65.0	9/GR5	
CLM00001	-103.20	15	-74.50	5.87	3.98	1.96	118	1	63.6	10	
CUB00001	-89.20	15	-79.81	21.62	2.24	0.80	168	1	61.1		
EQACAND1	-115.20	15	-78.40	-1.61	1.37	0.95	75	1	64.1	9/GR5	
EQAGAND1	-115.20	15	-90.34	-0.62	0.90	0.81	89	1	61.3	9/GR5	
GRD00002	-42.20	15	-61.58	12.29	0.80	0.80	90	1	58.8		
GRD00059	-57.20	15	-61.58	12.29	0.80	0.80	90	1	58.5		
GRLDNK01	-53.20	15	-44.89	66.56	2.70	0.82	173	1	60.0	2	10
GUY00201	-84.70	15	-59.19	4.78	1.44	0.85	95	1	63.5		
HWA00002	-166.20	15	-165.79	23.42	4.20	0.80	160	1	58.8	9/GR1	10
HWA00003	-175.20	15	-166.10	23.42	4.25	0.80	159	1	58.8	9/GR2	10
MEX01NTE	-78.20	15	-105.81	26.01	2.89	2.08	155	1	60.5	1	
MEX01SUR	-69.20	15	-94.84	19.82	3.05	2.09	4	1	62.3	1	10
MEX02NTE	-136.20	15	-107.21	26.31	3.84	1.55	148	1	61.2	1	10
MEX02SUR	-127.20	15	-96.39	19.88	3.18	1.87	157	1	62.6	1	10
PAQPAC01	-106.20	15	-109.18	-27.53	0.80	0.80	90	1	56.2	9/GR17	
PRG00002	-99.20	15	-58.66	-23.32	1.45	1.04	76	1	60.2		
PRUAND02	-115.20	15	-74.69	-8.39	3.41	1.79	95	1	64.0	9/GR5	
PTRVIR01	-101.20	15	-65.85	18.12	0.80	0.80	90	1	60.6	1 6 9/GR20	
PTRVIR02	-110.20	15	-65.86	18.12	0.80	0.80	90	1	61.0	1 6 9/GR21	
URG00001	-71.70	15	-56.22	-32.52	1.02	0.89	11	1	60.0		
USAEH001	-61.70	15	-85.19	36.21	5.63	3.33	22	1	61.8	1 5 6	10
USAEH002	-101.20	15	-89.24	36.16	5.67	3.76	170	1	61.7	1 6 9/GR20	10
USAEH003	-110.20	15	-90.14	36.11	5.55	3.55	161	1	62.1	1 6 9/GR21	10
USAEH004	-119.20	15	-91.16	36.05	5.38	3.24	152	1	62.6	1 5 6	10
USAPSA02	-166.20	15	-117.80	40.58	4.03	0.82	135	1	63.3	9/GR1	
USAPSA03	-175.20	15	-118.27	40.12	3.62	0.80	136	1	65.0	9/GR2	
USAWH101	-148.20	15	-109.65	38.13	5.53	1.95	142	1	62.1	10	
USAWH102	-157.20	15	-111.41	38.57	5.51	1.54	138	1	63.2	10	
VENAND03	-115.20	15	-67.04	6.91	2.37	1.43	111	1	67.3	9/GR5	

1	2	3	4		5		6	7	8	9	
ALS00002	-165.80	16	-149.63	58.52	3.81	1.23	171	2	59.8	9/GR1	10
ALS00003	-174.80	16	-150.95	58.54	3.77	1.11	167	2	60.0	9/GR2	10
ARGNORT4	-93.80	16	-63.96	-30.01	3.86	1.99	48	2	65.7	10	
ARGNORT5	-54.80	16	-62.85	-29.80	3.24	2.89	47	2	63.5	10	
B CE311	-63.80	16	-40.60	-6.07	3.04	2.06	174	2	61.6	8 9/GR7	10
B CE312	-44.80	16	-40.26	-6.06	3.44	2.09	174	2	61.0	8 9/GR9	10
B CE411	-63.80	16	-50.97	-15.26	3.86	1.38	49	2	62.6	8 9/GR7	10
B CE412	-44.80	16	-50.71	-15.30	3.57	1.56	52	2	62.8	8 9/GR9	10
B CE511	-63.80	16	-53.11	-2.98	2.42	2.15	107	2	63.1	8 9/GR7	10
B NO611	-73.80	16	-59.60	-11.62	2.86	1.69	165	1	62.9	8 9/GR8	10
B NO711	-73.80	16	-60.70	-1.78	3.54	1.78	126	1	62.8	8 9/GR8	10
B NO811	-73.80	16	-68.75	-4.71	2.37	1.65	73	1	62.8	8 9/GR8	10
B SE911	-101.80	16	-45.99	-19.09	2.22	0.80	62	2	65.3	8	10
B SU111	-80.80	16	-51.10	-25.64	2.76	1.06	50	2	62.9	8 9/GR6	10
B SU112	-44.80	16	-50.76	-25.62	2.47	1.48	56	2	62.3	8 9/GR9	10
B SU211	-80.80	16	-44.51	-16.94	3.22	1.37	60	2	62.5	8 9/GR6	10
B SU212	-44.80	16	-43.99	-16.97	3.27	1.92	59	2	61.3	8 9/GR9	10
CAN01101	-137.80	16	-125.60	57.24	3.45	1.27	157	2	59.5	9/GR10	10
CAN01201	-137.80	16	-111.92	55.89	3.33	0.98	151	2	59.6	9/GR10	10
CAN01202	-72.30	16	-107.64	55.62	2.75	1.11	32	2	59.6		
CAN01203	-128.80	16	-111.43	55.56	3.07	1.15	151	2	59.5	9/GR12	10
CAN01303	-128.80	16	-102.39	57.12	3.54	0.92	154	2	60.1	9/GR12	10
CAN01304	-90.80	16	-99.00	57.33	1.96	1.73	1	2	59.8	9/GR13	10
CAN01403	-128.80	16	-89.70	52.02	4.67	0.80	148	2	61.8	9/GR12	10
CAN01404	-90.80	16	-84.78	52.41	3.09	2.06	153	2	60.4	9/GR13	10
CAN01405	-81.80	16	-84.02	52.34	2.82	2.30	172	2	60.3	9/GR14	10
CAN01504	-90.80	16	-72.68	53.78	3.57	1.67	157	2	60.2	9/GR13	10
CAN01505	-81.80	16	-71.76	53.76	3.30	1.89	162	2	60.2	9/GR14	10
CAN01605	-81.80	16	-61.54	49.50	2.66	1.39	144	2	60.3	9/GR14	10
CAN01606	-70.30	16	-61.32	49.51	2.41	1.65	148	2	60.2	10	
CHLCONT4	-105.80	16	-69.59	-23.20	2.21	0.80	68	2	59.1	9/GR16	10
CHLCONT6	-105.80	16	-73.52	-55.52	3.65	1.31	39	2	59.6	9/GR16	10
CRBBAH01	-92.30	16	-76.09	24.13	1.83	0.80	141	1	61.7	9/GR18	10
CRBBER01	-92.30	16	-64.76	32.13	0.80	0.80	90	1	56.8	9/GR18	10
CRBBLZ01	-92.30	16	-88.61	17.26	0.80	0.80	90	1	58.7	9/GR18	10
CRBEC001	-92.30	16	-60.07	8.26	4.20	0.86	115	1	64.3	9/GR18	10
CRBJMC01	-92.30	16	-79.45	17.97	0.99	0.80	151	1	61.1	9/GR18	10
CYM00001	-115.80	16	-80.58	19.57	0.80	0.80	90	2	59.6		
DOMIFRB2	-83.30	16	-70.51	18.79	0.98	0.80	167	2	61.1		
EQAC0001	-94.80	16	-78.31	-1.52	1.48	1.15	65	1	63.0	9/GR19	10
EQAG0001	-94.80	16	-90.36	-0.57	0.94	0.89	99	1	61.0	9/GR19	10
GUFMGG02	-52.80	16	-56.42	8.47	4.16	0.81	123	2	62.7	2 7	10
HWA00002	-165.80	16	-165.79	23.32	4.20	0.80	160	2	58.8	9/GR1	10
HWA00003	-174.80	16	-166.10	23.42	4.25	0.80	159	2	58.8	9/GR2	10
JMC00005	-33.80	16	-77.27	18.12	0.80	0.80	90	2	60.6		
LCAIFRB1	-79.30	16	-61.15	13.90	0.80	0.80	90	2	58.4		
MEX01NTE	-77.80	16	-105.80	25.99	2.88	2.07	155	2	60.5	1	
MEX02NTE	-135.80	16	-107.36	26.32	3.80	1.57	149	2	61.2	1	10
MEX02SUR	-126.80	16	-96.39	19.88	3.19	1.87	158	2	62.5	1	10
PRU00004	-85.80	16	-74.19	-8.39	3.74	2.45	112	2	62.9	10	
PTRVIR01	-100.80	16	-65.85	18.12	0.80	0.80	90	2	60.6	1 6 9/GR20	
PTRVIR02	-109.80	16	-65.85	18.12	0.80	0.80	90	2	61.1	1 6 9/GR21	
SLVIFRB2	-107.30	16	-88.91	13.59	0.80	0.80	90	1	61.7		
USAEH001	-61.30	16	-85.16	36.21	5.63	3.32	22	2	61.9	1 5 6	10
USAEH002	-100.80	16	-89.28	36.16	5.65	3.78	170	2	61.7	1 6 9/GR20	10
USAEH003	-109.80	16	-90.12	36.11	5.55	3.56	161	2	62.1	1 6 9/GR21	10
USAEH004	-118.80	16	-91.16	36.05	5.38	3.24	153	2	62.6	1 5 6	10
USAPSA02	-165.80	16	-117.79	40.58	4.04	0.82	135	2	63.3	9/GR1	10
USAPSA03	-174.80	16	-118.20	40.15	3.63	0.80	136	2	63.0	9/GR2	10
USAWH101	-147.80	16	-109.70	38.13	5.52	1.96	142	2	62.1	10	
USAWH102	-156.80	16	-111.40	38.57	5.51	1.55	138	2	63.2	10	
VEN11VEN	-103.80	16	-66.79	6.90	2.50	1.77	122	2	65.2	10	

12 457.28 MHz (17)

1	2	3	4	5	6	7	8	9			
ALS00002	-166.20	17	-149.66	58.37	3.76	1.24	170	1	59.9	9/GR1	10
ALS00003	-175.20	17	-150.98	58.53	3.77	1.11	167	1	60.2	9/GR2	10
ARGINSU4	-94.20	17	-52.98	-59.81	3.40	0.80	19	1	60.1	9/GR3	
ARGINSU5	-55.20	17	-44.17	-59.91	3.77	0.80	13	1	59.5	9/GR4	10
ARGSUR04	-94.20	17	-65.04	-43.33	3.32	1.50	40	1	60.9	9/GR3	10
ARGSUR05	-55.20	17	-63.68	-43.01	2.54	2.38	152	1	60.2	9/GR4	10
B CE311	-64.20	17	-40.60	-6.07	3.04	2.06	174	1	61.9	8 9/GR7	10
B CE312	-45.20	17	-40.27	-6.06	3.44	2.09	174	1	61.2	8 9/GR9	10
B CE411	-64.20	17	-50.97	-15.27	3.86	1.38	49	1	62.9	8 9/GR7	10
B CE412	-45.20	17	-50.71	-15.30	3.57	1.56	52	1	63.0	8 9/GR9	10
B CE511	-64.20	17	-53.10	-2.90	2.44	2.13	104	1	63.4	8 9/GR7	10
B NO611	-74.20	17	-59.60	-11.62	2.85	1.69	165	2	63.1	8 9/GR8	10
B NO711	-74.20	17	-60.70	-1.78	3.54	1.78	126	2	63.1	8 9/GR8	10
B NO811	-74.20	17	-68.76	-4.71	2.37	1.65	73	2	63.1	8 9/GR8	
B SU111	-81.20	17	-51.12	-25.63	2.76	1.05	50	1	63.2	8 9/GR6	10
B SU112	-45.20	17	-50.75	-25.62	2.47	1.48	56	1	62.5	8 9/GR9	
B SU211	-81.20	17	-44.51	-16.95	3.22	1.36	60	1	62.8	8 9/GR6	10
B SU212	-45.20	17	-44.00	-16.87	3.20	1.96	58	1	61.6	8 9/GR9	
BERBERMU	-96.20	17	-64.77	32.32	0.80	0.80	90	2	57.0		
BERBER02	-31.00	17	-64.77	32.32	0.80	0.80	90	1	57.1	2	10
BOLAND01	-115.20	17	-65.04	-16.76	2.49	1.27	76	1	68.0	9/GR5	
CAN01101	-138.20	17	-125.63	57.24	3.45	1.27	157	1	59.7	9/GR10	10
CAN01201	-138.20	17	-112.04	55.95	3.35	0.97	151	1	59.8	9/GR10	10
CAN01202	-72.70	17	-107.70	55.63	2.74	1.12	32	1	59.8		
CAN01203	-129.20	17	-111.48	55.61	3.08	1.15	151	1	59.7	9/GR12	10
CAN01303	-129.20	17	-102.42	57.12	3.54	0.91	154	1	60.2	9/GR12	10
CAN01304	-91.20	17	-99.12	57.36	1.98	1.72	2	1	60.0	9/GR13	
CAN01403	-129.20	17	-89.75	52.02	4.68	0.80	148	1	62.1	9/GR12	10
CAN01404	-91.20	17	-84.82	52.42	3.10	2.05	152	1	60.6	9/GR13	10
CAN01405	-82.20	17	-84.00	52.39	2.84	2.29	172	1	60.5	9/GR14	10
CAN01504	-91.20	17	-72.66	53.77	3.57	1.67	156	1	60.4	9/GR13	10
CAN01505	-82.20	17	-71.77	53.79	3.30	1.89	162	1	60.3	9/GR14	10
CAN01605	-82.20	17	-61.50	49.55	2.65	1.40	143	1	60.5	9/GR14	10
CAN01606	-70.70	17	-61.30	49.55	2.40	1.65	148	1	60.4	10	
CHLCONT5	-106.20	17	-72.23	-35.57	2.60	0.80	55	1	59.6	9/GR17	
CHLPAC02	-106.20	17	-80.06	-30.06	1.36	0.80	69	1	59.4	9/GR17	
CLMAND01	-115.20	17	-74.72	5.93	3.85	1.63	114	1	65.3	9/GR5	
CLM00001	-103.20	17	-74.50	5.87	3.98	1.96	118	1	63.9	10	
EQACAND1	-115.20	17	-78.40	-1.61	1.37	0.95	75	1	64.4	9/GR5	
EQAGAND1	-115.20	17	-90.34	-0.62	0.90	0.81	89	1	61.5	9/GR5	
FLKFALKS	-31.00	17	-59.90	-51.64	0.80	0.80	90	1	58.2	2	
HWA00002	-166.20	17	-165.79	23.42	4.20	0.80	160	1	59.0	9/GR1	10
HWA00003	-175.20	17	-166.10	23.42	4.25	0.80	159	1	58.9	9/GR2	10
JMC00002	-92.70	17	-77.30	18.12	0.80	0.80	90	2	60.1		
KNA00001	-79.70	17	-62.46	17.44	0.80	0.80	90	1	58.6		
MEX01NTE	-78.20	17	-105.81	26.01	2.89	2.08	155	1	60.7	1	
MEX01SUR	-69.20	17	-94.84	19.82	3.05	2.09	4	1	62.5	1	10
MEX02NTE	-136.20	17	-107.21	26.31	3.84	1.55	148	1	61.4	1	10
MEX02SUR	-127.20	17	-96.39	19.88	3.18	1.87	157	1	62.8	1	10
PAQPAC01	-106.20	17	-109.18	-27.53	0.80	0.80	90	1	56.4	9/GR17	
PRG00002	-99.20	17	-58.66	-23.32	1.45	1.04	76	1	60.4		
PRUAND02	-115.20	17	-74.69	-8.39	3.41	1.79	95	1	64.3	9/GR5	
PTRVIR01	-101.20	17	-65.85	18.12	0.80	0.80	90	1	60.8	1 6 9/GR20	
PTRVIR02	-110.20	17	-65.86	18.12	0.80	0.80	90	1	61.3	1 6 9/GR21	
SPMFRAN3	-53.20	17	-67.24	47.51	3.16	0.80	7	1	60.6	2 7	10
SURINAM2	-84.70	17	-55.69	4.35	1.00	0.80	86	1	63.5		
URG00001	-71.70	17	-56.22	-32.52	1.02	0.89	11	1	60.2		
USAEH001	-61.70	17	-85.19	36.21	5.63	3.33	22	1	62.1	1 5 6	10
USAEH002	-101.20	17	-89.24	36.16	5.67	3.76	170	1	62.0	1 6 9/GR20	10
USAEH003	-110.20	17	-90.14	36.11	5.55	3.55	161	1	62.3	1 6 9/GR21	10
USAEH004	-119.20	17	-91.16	36.05	5.38	3.24	152	1	62.9	1 5 6	10
USAPSA02	-166.20	17	-117.80	40.58	4.03	0.82	135	1	63.5	9/GR1	
USAPSA03	-175.20	17	-118.27	40.12	3.62	0.80	136	1	65.3	9/GR2	
USAWH101	-148.20	17	-109.65	38.13	5.53	1.95	142	1	62.3	10	
USAWH102	-157.20	17	-111.41	38.57	5.51	1.54	138	1	63.5	10	
VENAND03	-115.20	17	-67.04	6.91	2.37	1.43	111	1	67.6	9/GR5	



1	2	3	4		5		6	7	8	9	
ALS00002	-165.80	18	-149.63	58.52	3.81	1.23	171	2	59.9	9/GR1	10
ALS00003	-174.80	18	-150.95	58.54	3.77	1.11	167	2	60.2	9/GR2	10
ARGNORT4	-93.80	18	-63.96	-30.01	3.86	1.99	48	2	66.0	10	
ARGNORT5	-54.80	18	-62.85	-29.80	3.24	2.89	47	2	63.8	10	
ATNBEAM1	-52.80	18	-66.44	14.87	1.83	0.80	39	2	61.3		
B CE311	-63.80	18	-40.60	-6.07	3.04	2.06	174	2	61.9	8 9/GR7	
B CE312	-44.80	18	-40.26	-6.06	3.44	2.09	174	2	61.2	8 9/GR9	10
B CE411	-63.80	18	-50.97	-15.26	3.86	1.38	49	2	62.9	8 9/GR7	10
B CE412	-44.80	18	-50.71	-15.30	3.57	1.56	52	2	63.0	8 9/GR9	10
B CE511	-63.80	18	-53.11	-2.98	2.42	2.15	107	2	63.4	8 9/GR7	10
B NO611	-73.80	18	-59.60	-11.62	2.86	1.69	165	1	63.1	8 9/GR8	10
B NO711	-73.80	18	-60.70	-1.78	3.54	1.78	126	1	63.1	8 9/GR8	10
B NO811	-73.80	18	-68.75	-4.71	2.37	1.65	73	1	63.1	8 9/GR8	10
B SE911	-101.80	18	-45.99	-19.09	2.22	0.80	62	2	65.7	8	10
B SU111	-80.80	18	-51.10	-25.64	2.76	1.06	50	2	63.1	8 9/GR6	10
B SU112	-44.80	18	-50.76	-25.62	2.47	1.48	56	2	62.6	8 9/GR9	
B SU211	-80.80	18	-44.51	-16.94	3.22	1.37	60	2	62.8	8 9/GR6	10
B SU212	-44.80	18	-43.99	-16.97	3.27	1.92	59	2	61.6	8 9/GR9	
BLZ00001	-115.80	18	-88.68	17.27	0.80	0.80	90	2	59.2		
CAN01101	-137.80	18	-125.60	57.24	3.45	1.27	157	2	59.7	9/GR10	10
CAN01201	-137.80	18	-111.92	55.89	3.33	0.98	151	2	59.8	9/GR10	10
CAN01202	-72.30	18	-107.64	55.62	2.75	1.11	32	2	59.8		
CAN01203	-128.80	18	-111.43	55.56	3.07	1.15	151	2	59.7	9/GR12	10
CAN01303	-128.80	18	-102.39	57.12	3.54	0.92	154	2	60.3	9/GR12	10
CAN01304	-90.80	18	-99.00	57.33	1.96	1.73	1	2	60.0	9/GR13	
CAN01403	-128.80	18	-89.70	52.02	4.67	0.80	148	2	62.1	9/GR12	10
CAN01404	-90.80	18	-84.78	52.41	3.09	2.06	153	2	60.6	9/GR13	10
CAN01405	-81.80	18	-84.02	52.34	2.82	2.30	172	2	60.5	9/GR14	10
CAN01504	-90.80	18	-72.68	53.78	3.57	1.67	157	2	60.4	9/GR13	10
CAN01505	-81.80	18	-71.76	53.76	3.30	1.89	162	2	60.3	9/GR14	10
CAN01605	-81.80	18	-61.54	49.50	2.66	1.39	144	2	60.5	9/GR14	10
CAN01606	-70.30	18	-61.32	49.51	2.41	1.65	148	2	60.4	10	
CHLCONT4	-105.80	18	-69.59	-23.20	2.21	0.80	68	2	59.3	9/GR16	
CHLCONT6	-105.80	18	-73.52	-55.52	3.65	1.31	39	2	59.7	9/GR16	
CRBBAH01	-92.30	18	-76.09	24.13	1.83	0.80	141	1	61.9	9/GR18	
CRBBER01	-92.30	18	-64.76	32.13	0.80	0.80	90	1	56.9	9/GR18	
CRBBLZ01	-92.30	18	-88.61	17.26	0.80	0.80	90	1	58.9	9/GR18	
CRBEC001	-92.30	18	-60.07	8.26	4.20	0.86	115	1	64.6	9/GR18	10
CRBJMC01	-92.30	18	-79.45	17.97	0.99	0.80	151	1	61.3	9/GR18	
CTR00201	-130.80	18	-84.33	9.67	0.82	0.80	119	2	66.0		
DMAIFRB1	-79.30	18	-61.30	15.35	0.80	0.80	90	2	58.7		
EQAC0001	-94.80	18	-78.31	-1.52	1.48	1.15	65	1	63.3	9/GR19	
EQAG0001	-94.80	18	-90.36	-0.57	0.94	0.89	99	1	61.2	9/GR19	
HWAA0002	-165.80	18	-165.79	23.32	4.20	0.80	160	2	59.0	9/GR1	10
HWAA0003	-174.80	18	-166.10	23.42	4.25	0.80	159	2	59.0	9/GR2	10
MEX01NTE	-77.80	18	-105.80	25.99	2.88	2.07	155	2	60.7	1	
MEX02NTE	-135.80	18	-107.36	26.32	3.80	1.57	149	2	61.4	1	10
MEX02SUR	-126.80	18	-96.39	19.88	3.19	1.87	158	2	62.8	1	10
NCG00003	-107.30	18	-84.99	12.90	1.05	1.01	176	1	63.6		
PRU00004	-85.80	18	-74.19	-8.39	3.74	2.45	112	2	63.1	10	
PTRVIR01	-100.80	18	-65.85	18.12	0.80	0.80	90	2	60.8	1 6 9/GR20	
PTRVIR02	-109.80	18	-65.85	18.12	0.80	0.80	90	2	61.4	1 6 9/GR21	
USAEH001	-61.30	18	-85.16	36.21	5.63	3.32	22	2	62.1	1 5 6	10
USAEH002	-100.80	18	-89.28	36.16	5.65	3.78	170	2	62.0	1 6 9/GR20	10
USAEH003	-109.80	18	-90.12	36.11	5.55	3.56	161	2	62.3	1 6 9/GR21	10
USAEH004	-118.80	18	-91.16	36.05	5.38	3.24	153	2	62.9	1 5 6	10
USAPSA02	-165.80	18	-117.79	40.58	4.04	0.82	135	2	63.5	9/GR1	
USAPSA03	-174.80	18	-118.20	40.15	3.63	0.80	136	2	65.3	9/GR2	
USAWH101	-147.80	18	-109.70	38.13	5.52	1.96	142	2	62.3	10	
USAWH102	-156.80	18	-111.40	38.57	5.51	1.55	138	2	63.5	10	
VEN11VEN	-103.80	18	-66.79	6.90	2.50	1.77	122	2	65.5	10	

12 486.44 MHz (19)

1	2	3	4	5	6	7	8	9			
ALS00002	-166.20	19	-149.66	58.37	3.76	1.24	170	1	60.0	9/GR1	10
ALS00003	-175.20	19	-150.98	58.53	3.77	1.11	167	1	60.2	9/GR2	10
ARGINSU4	-94.20	19	-52.98	-59.81	3.40	0.80	19	1	60.1	9/GR3	
ARGINSU5	-55.20	19	-44.17	-59.91	3.77	0.80	13	1	59.5	9/GR4	10
ARGSUR04	-94.20	19	-65.04	-43.33	3.32	1.50	40	1	60.9	9/GR3	10
ARGSUR05	-55.20	19	-63.68	-43.01	2.54	2.38	152	1	60.3	9/GR4	10
B CE311	-64.20	19	-40.60	-6.07	3.04	2.06	174	1	61.9	8/9/GR7	10
B CE312	-45.20	19	-40.27	-6.06	3.44	2.09	174	1	61.3	8/9/GR9	10
B CE411	-64.20	19	-50.97	-15.27	3.86	1.38	49	1	62.9	8/9/GR7	10
B CE412	-45.20	19	-50.71	-15.30	3.57	1.56	52	1	63.1	8/9/GR9	10
B CE511	-64.20	19	-53.10	-2.90	2.44	2.13	104	1	63.4	8/9/GR7	10
B NO611	-74.20	19	-59.60	-11.62	2.85	1.69	165	2	63.2	8/9/GR8	10
B NO711	-74.20	19	-60.70	-1.78	3.54	1.78	126	2	63.2	8/9/GR8	10
B NO811	-74.20	19	-68.76	-4.71	2.37	1.65	73	2	63.1	8/9/GR8	
B SU111	-81.20	19	-51.12	-25.63	2.76	1.05	50	1	63.2	8/9/GR6	10
B SU112	-45.20	19	-50.75	-25.62	2.47	1.48	56	1	62.6	8/9/GR9	
B SU211	-81.20	19	-44.51	-16.95	3.22	1.36	60	1	62.8	8/9/GR6	10
B SU212	-45.20	19	-44.00	-16.87	3.20	1.96	58	1	61.6	8/9/GR9	
BERBERMU	-96.20	19	-64.77	32.32	0.80	0.80	90	2	57.0		
BOLAND01	-115.20	19	-65.04	-16.76	2.49	1.27	76	1	68.1	9/GR5	
BOL00001	-87.20	19	-64.61	-16.71	2.52	2.19	85	1	64.2	10	
BRB00001	-92.70	19	-59.85	12.93	0.80	0.80	90	2	59.4		
CAN01101	-138.20	19	-125.63	57.24	3.45	1.27	157	1	59.7	9/GR10	10
CAN01201	-138.20	19	-112.04	55.95	3.35	0.97	151	1	59.8	9/GR10	10
CAN01202	-72.70	19	-107.70	55.63	2.74	1.12	32	1	59.8		
CAN01203	-129.20	19	-111.48	55.61	3.08	1.15	151	1	59.7	9/GR12	10
CAN01303	-129.20	19	-102.42	57.12	3.54	0.91	154	1	60.3	9/GR12	10
CAN01304	-91.20	19	-99.12	57.36	1.98	1.72	2	1	60.1	9/GR13	
CAN01403	-129.20	19	-89.75	52.02	4.68	0.80	148	1	62.1	9/GR12	10
CAN01404	-91.20	19	-84.82	52.42	3.10	2.05	152	1	60.6	9/GR13	10
CAN01405	-82.20	19	-84.00	52.39	2.84	2.29	172	1	60.5	9/GR14	10
CAN01504	-91.20	19	-72.66	53.77	3.57	1.67	156	1	60.4	9/GR13	10
CAN01505	-82.20	19	-71.77	53.79	3.30	1.89	162	1	60.4	9/GR14	10
CAN01605	-82.20	19	-61.50	49.55	2.65	1.40	143	1	60.5	9/GR14	10
CAN01606	-70.70	19	-61.30	49.55	2.60	1.65	148	1	60.5	10	
CHLCONT5	-106.20	19	-72.23	-35.57	2.60	0.80	55	1	59.6	9/GR17	
CHLPAC02	-106.20	19	-80.06	-30.06	1.36	0.80	69	1	59.4	9/GR17	
CLMAND01	-115.20	19	-74.72	5.93	3.85	1.63	114	1	65.4	9/GR5	
CLM00001	-103.20	19	-74.50	5.87	3.98	1.96	118	1	63.9	10	
CUB00001	-89.20	19	-79.81	21.62	2.24	0.80	168	1	61.3		
EQACAND1	-115.20	19	-78.40	-1.61	1.37	0.95	75	1	64.4	9/GR5	
EQAGAND1	-115.20	19	-90.34	-0.62	0.90	0.81	89	1	61.6	9/GR5	
GRD00059	-57.20	19	-61.58	12.29	0.80	0.80	90	1	58.7		
GRLDNK01	-53.20	19	-44.89	66.56	2.70	0.82	173	1	60.2	2	10
GUY00201	-84.70	19	-59.19	4.78	1.44	0.85	95	1	63.8		
HWA00002	-166.20	19	-165.79	23.42	4.20	0.80	160	1	59.0	9/GR1	10
HWA00003	-175.20	19	-166.10	23.42	4.25	0.80	159	1	59.0	9/GR2	10
MEX01INTE	-78.20	19	-105.81	26.01	2.89	2.08	155	1	60.8	1	
MEX01SUR	-69.20	19	-94.84	19.82	3.05	2.09	4	1	62.5	1	10
MEX02NTE	-136.20	19	-107.21	26.31	3.84	1.55	148	1	61.5	1	10
MEX02SUR	-127.20	19	-96.39	19.88	3.18	1.87	157	1	62.8	1	10
MSR00001	-79.70	19	-61.73	16.75	0.80	0.80	90	1	58.9	4	
PAQPAC01	-106.20	19	-109.18	-27.53	0.80	0.80	90	1	56.4	9/GR17	
PRG00002	-99.20	19	-58.66	-23.32	1.45	1.04	76	1	60.5		
PRUAND02	-115.20	19	-74.69	-8.39	3.41	1.79	95	1	64.3	9/GR5	
PTRVIR01	-101.20	19	-65.85	18.12	0.80	0.80	90	1	60.8	1 6 9/GR20	
PTRVIR02	-110.20	19	-65.86	18.12	0.80	0.80	90	1	61.3	1 6 9/GR21	
URG00001	-71.70	19	-56.22	-32.52	1.02	0.89	11	1	60.2		
USAEH001	-61.70	19	-85.19	36.21	5.63	3.33	22	1	62.1	1 5 6	10
USAEH002	-101.20	19	-89.24	36.16	5.67	3.76	170	1	62.0	1 6 9/GR20	10
USAEH003	-110.20	19	-90.14	36.11	5.55	3.55	161	1	62.4	1 6 9/GR21	10
USAEH004	-119.20	19	-91.16	36.05	5.38	3.24	152	1	62.9	1 5 6	10
USAPSA02	-166.20	19	-117.80	40.58	4.03	0.82	135	1	63.6	9/GR1	
USAPSA03	-175.20	19	-118.27	40.12	3.62	0.80	136	1	65.4	9/GR2	
USAWH101	-148.20	19	-109.65	38.13	5.53	1.95	142	1	62.4	10	
USAWH102	-157.20	19	-111.41	38.57	5.51	1.54	138	1	63.5	10	
VENAND03	-115.20	19	-67.04	6.91	2.37	1.43	111	1	67.7	9/GR5	

1	2	3	4	5	6	7	8	9			
ALS00002	-165.80	20	-149.63	58.52	3.81	1.23	171	2	59.9	9/GR1	10
ALS00003	-174.80	20	-150.95	58.54	3.77	1.11	167	2	60.2	9/GR2	10
ARGNORT4	-93.80	20	-63.96	-30.01	3.86	1.99	48	2	66.1	10	
ARGNORT5	-54.80	20	-62.85	-29.80	3.24	2.89	47	2	63.9	10	
B CE311	-63.80	20	-40.60	-6.07	3.04	2.06	174	2	61.9	8 9/GR7	10
B CE312	-44.80	20	-40.26	-6.06	3.44	2.09	174	2	61.3	8 9/GR9	10 11
B CE411	-63.80	20	-50.97	-15.26	3.86	1.38	49	2	62.9	8 9/GR7	10
B CE412	-44.80	20	-50.71	-15.30	3.57	1.56	52	2	63.1	8 9/GR9	10 12
B CE511	-63.80	20	-53.11	-2.98	2.42	2.15	107	2	63.4	8 9/GR7	10
B NO611	-73.80	20	-59.60	-11.62	2.86	1.69	165	1	63.2	8 9/GR8	10
B NO711	-73.80	20	-60.70	-1.78	3.54	1.78	126	1	63.2	8 9/GR8	10
B NO811	-73.80	20	-68.75	-4.71	2.37	1.65	73	1	63.2	8 9/GR8	
B SE911	-101.80	20	-45.99	-19.09	2.22	0.80	62	2	65.7	8	10
B SU111	-80.80	20	-51.10	-25.64	2.76	1.06	50	2	63.2	8 9/GR6	10
B SU112	-44.80	20	-50.76	-25.62	2.47	1.48	56	2	62.6	8 9/GR9	11
B SU211	-80.80	20	-44.51	-16.94	3.22	1.37	60	2	62.8	8 9/GR6	10
B SU212	-44.80	20	-43.99	-16.97	3.27	1.92	59	2	61.6	8 9/GR9	12
CAN01101	-137.80	20	-125.60	57.24	3.45	1.27	157	2	59.7	9/GR10	10
CAN01201	-137.80	20	-111.92	55.89	3.33	0.98	151	2	59.8	9/GR10	10
CAN01202	-72.30	20	-107.64	55.62	2.75	1.11	32	2	59.8		
CAN01203	-128.80	20	-111.43	55.56	3.07	1.15	151	2	59.7	9/GR12	10
CAN01303	-128.80	20	-102.39	57.12	3.54	0.92	154	2	60.3	9/GR12	10
CAN01304	-90.80	20	-99.00	57.33	1.96	1.73	1	2	60.0	9/GR13	
CAN01403	-128.80	20	-89.70	52.02	4.67	0.80	148	2	62.1	9/GR12	10
CAN01404	-90.80	20	-84.78	52.41	3.09	2.06	153	2	60.6	9/GR13	10
CAN01405	-81.80	20	-84.02	52.34	2.82	2.30	172	2	60.5	9/GR14	10
CAN01504	-90.80	20	-72.68	53.78	3.57	1.67	157	2	60.4	9/GR13	10
CAN01505	-81.80	20	-71.76	53.76	3.30	1.89	162	2	60.4	9/GR14	10
CAN01605	-81.80	20	-61.54	49.50	2.66	1.39	144	2	60.5	9/GR14	10
CAN01606	-70.30	20	-61.32	49.51	2.41	1.65	148	2	60.5	10	
CHLCONT4	-105.80	20	-69.59	-23.20	2.21	0.80	68	2	59.3	9/GR16	
CHLCONT6	-105.80	20	-73.52	-55.52	3.65	1.31	39	2	59.8	9/GR16	
CRBBAH01	-92.30	20	-76.09	24.13	1.83	0.80	141	1	62.0	9/GR18	
CRBBER01	-92.30	20	-64.76	32.13	0.80	0.80	90	1	57.0	9/GR18	
CRBBLZ01	-92.30	20	-88.61	17.26	0.80	0.80	90	1	58.9	9/GR18	
CRBEC001	-92.30	20	-60.07	8.26	4.20	0.86	115	1	64.6	9/GR18	10
CRBJMC01	-92.30	20	-79.45	17.97	0.99	0.80	151	1	61.4	9/GR18	
EQAC0001	-94.80	20	-78.31	-1.52	1.48	1.15	65	1	63.3	9/GR19	
EQAG0001	-94.80	20	-90.36	-0.57	0.94	0.89	99	1	61.3	9/GR19	
GRD00003	-79.30	20	-61.62	12.34	0.80	0.80	90	2	58.9		
GTMIFRB2	-107.30	20	-90.50	15.64	1.03	0.80	84	1	61.4		
GUFMGG02	-52.80	20	-56.42	8.47	4.16	0.81	123	2	63.0	2 7	10
HWA00002	-165.80	20	-165.79	23.32	4.20	0.80	160	2	59.0	9/GR1	10
HWA00003	-174.80	20	-166.10	23.42	4.25	0.80	159	2	59.0	9/GR2	10
MEX01NTE	-77.80	20	-105.80	25.99	2.88	2.07	155	2	60.8	1	
MEX02NTE	-135.80	20	-107.36	26.32	3.80	1.57	149	2	61.5	1	10
MEX02SUR	-126.80	20	-96.39	19.88	3.19	1.87	158	2	62.8	1	10
PNRIFRB2	-121.00	20	-80.15	8.46	1.01	0.80	170	1	65.1		
PRU00004	-85.80	20	-74.19	-8.39	3.74	2.45	112	2	63.2	10	
PTRVIR01	-100.80	20	-65.85	18.12	0.80	0.80	90	2	60.9	1 6 9/GR20	
PTRVIR02	-109.80	20	-65.85	18.12	0.80	0.80	90	2	61.4	1 6 9/GR21	
USAEH001	-61.30	20	-85.16	36.21	5.63	3.32	22	2	62.1	1 5 6	10
USAEH002	-100.80	20	-89.28	36.16	5.65	3.78	170	2	62.0	1 6 9/GR20	10
USAEH003	-109.80	20	-90.12	36.11	5.55	3.56	161	2	62.4	1 6 9/GR21	10
USAEH004	-118.80	20	-91.16	36.05	5.38	3.24	153	2	62.9	1 5 6	10
USAPSA02	-165.80	20	-117.79	40.58	4.04	0.82	135	2	63.6	9/GR1	
USAPSA03	-174.80	20	-118.20	40.15	3.63	0.80	136	2	65.3	9/GR2	
USAWH01	-147.80	20	-109.70	38.13	5.52	1.96	142	2	62.4	10	
USAWH02	-156.80	20	-111.40	38.57	5.51	1.55	138	2	63.5	10	
VEN02VEN	-103.80	20	-63.50	15.50	0.80	0.80	90	2	60.1	9/GR22	
VEN11VEN	-103.80	20	-66.79	6.90	2.50	1.77	122	2	65.6	9/GR22	10

## 12 515.60 MHz (21)

1	2	3	4	5	6	7	8	9			
ALS00002	-166.20	21	-149.66	58.37	3.76	1.24	170	1	59.9	9/GR1	10
ALS00003	-175.20	21	-150.98	58.53	3.77	1.11	167	1	60.2	9/GR2	10
ARGINSU4	-94.20	21	-52.98	-59.81	3.40	0.80	19	1	60.1	9/GR3	
ARGINSU5	-55.20	21	-44.17	-59.91	3.77	0.80	13	1	59.5	9/GR4	
ARGSUR04	-94.20	21	-65.04	-43.33	3.32	1.50	40	1	60.9	9/GR3	
ARGSUR05	-55.20	21	-63.68	-43.01	2.54	2.38	152	1	60.2	9/GR4	
B CE311	-64.20	21	-40.60	-6.07	3.04	2.06	174	1	61.9	8 9/GR7	
B CE312	-45.20	21	-40.27	-6.06	3.44	2.09	174	1	61.2	8 9/GR9	1011
B CE411	-64.20	21	-50.97	-15.27	3.86	1.38	49	1	62.9	8 9/GR7	
B CE412	-45.20	21	-50.71	-15.30	3.57	1.56	52	1	63.0	8 9/GR9	1012
B CE511	-64.20	21	-53.10	-2.90	2.44	2.13	104	1	63.4	8 9/GR7	
B NO611	-74.20	21	-59.60	-11.62	2.85	1.69	165	2	63.1	8 9/GR8	
B NO711	-74.20	21	-60.70	-1.78	3.54	1.78	126	2	63.1	8 9/GR8	
B NO811	-74.20	21	-68.76	-4.71	2.37	1.65	73	2	63.1	8 9/GR8	
B SU111	-81.20	21	-51.12	-25.63	2.76	1.05	50	1	63.2	8 9/GR6	
B SU112	-45.20	21	-50.75	-25.62	2.47	1.48	56	1	62.5	8 9/GR9	11
B SU211	-81.20	21	-44.51	-16.95	3.22	1.36	60	1	62.8	8 9/GR6	
B SU212	-45.20	21	-44.00	-16.87	3.20	1.96	58	1	61.6	8 9/GR9	12
BERBERMU	-96.20	21	-64.77	32.32	0.80	0.80	90	2	57.0		
BOLAND01	-115.20	21	-65.04	-16.76	2.49	1.27	76	1	68.0	9/GR5	
CAN01101	-138.20	21	-125.63	57.24	3.45	1.27	157	1	59.7	9/GR10	10
CAN01201	-138.20	21	-112.04	55.95	3.35	0.97	151	1	59.8	9/GR10	10
CAN01202	-72.70	21	-107.70	55.63	2.74	1.12	32	1	59.8		
CAN01203	-129.20	21	-111.48	55.61	3.08	1.15	151	1	59.7	9/GR12	10
CAN01303	-129.20	21	-102.42	57.12	3.54	0.91	154	1	60.2	9/GR12	10
CAN01304	-91.20	21	-99.12	57.36	1.98	1.72	2	1	60.0	9/GR13	
CAN01403	-129.20	21	-89.75	52.02	4.68	0.80	148	1	62.1	9/GR12	10
CAN01404	-91.20	21	-84.82	52.42	3.10	2.05	152	1	60.6	9/GR13	
CAN01405	-82.20	21	-84.00	52.39	2.84	2.29	172	1	60.5	9/GR14	
CAN01504	-91.20	21	-72.66	53.77	3.57	1.67	156	1	60.4	9/GR13	
CAN01505	-82.20	21	-71.77	53.79	3.30	1.89	162	1	60.3	9/GR14	
CAN01605	-82.20	21	-61.50	49.55	2.65	1.40	143	1	60.5	9/GR14	
CAN01606	-70.70	21	-61.30	49.55	2.40	1.65	148	1	60.4		
CHLCONT5	-106.20	21	-72.23	-35.57	2.60	0.80	55	1	59.6	9/GR17	
CHLPAC02	-106.20	21	-80.06	-30.06	1.36	0.80	69	1	59.4	9/GR17	
CLMAND01	-115.20	21	-74.72	5.93	3.85	1.63	114	1	65.3	9/GR5	10
CLM00001	-103.20	21	-74.50	5.87	3.98	1.96	118	1	63.9	10	
EQACAND1	-115.20	21	-78.40	-1.61	1.37	0.95	75	1	64.4	9/GR5	
EQAGAND1	-115.20	21	-90.34	-0.62	0.90	0.81	89	1	61.5	9/GR5	
HWA00002	-166.20	21	-165.79	23.42	4.20	0.80	160	1	59.0	9/GR1	10
HWA00003	-175.20	21	-166.10	23.42	4.25	0.80	159	1	58.9	9/GR2	10
JMC00002	-92.70	21	-77.30	18.12	0.80	0.80	90	2	60.1		
KNA00001	-79.70	21	-62.46	17.44	0.80	0.80	90	1	58.6		
MEX01NTE	-78.20	21	-105.81	26.01	2.89	2.08	155	1	60.7	1	
MEX01SUR	-69.20	21	-94.84	19.82	3.05	2.09	4	1	62.5	1	10
MEX02NTE	-136.20	21	-107.21	26.31	3.84	1.55	148	1	61.4	1	10
MEX02SUR	-127.20	21	-96.39	19.88	3.18	1.87	157	1	62.8	1	10
PAQPAC01	-106.20	21	-109.18	-27.53	0.80	0.80	90	1	56.4	9/GR17	
PRG00002	-99.20	21	-58.66	-23.32	1.45	1.04	76	1	60.4		
PRUAND02	-115.20	21	-74.69	-8.39	3.41	1.79	95	1	64.3	9/GR5	
PTRVIR01	-101.20	21	-65.85	18.12	0.80	0.80	90	1	60.8	1 6 9/GR20	
PTRVIR02	-110.20	21	-65.86	18.12	0.80	0.80	90	1	61.3	1 6 9/GR21	
SPMFRAN3	-53.20	21	-67.24	47.51	3.16	0.80	7	1	60.6	2 7	
SURINAM2	-84.70	21	-55.69	4.35	1.00	0.80	86	1	63.5		
URG00001	-71.70	21	-56.22	-32.52	1.02	0.89	11	1	60.2		
USAEH001	-61.70	21	-85.19	36.21	5.63	3.33	22	1	62.1	1 5 6	
USAEH002	-101.20	21	-89.24	36.16	5.67	3.76	170	1	62.0	1 6 9/GR20	10
USAEH003	-110.20	21	-90.14	36.11	5.55	3.55	161	1	62.3	1 6 9/GR21	10
USAEH004	-119.20	21	-91.16	36.05	5.38	3.24	152	1	62.9	1 5 6	10
USAPSA02	-166.20	21	-117.80	40.58	4.03	0.82	135	1	63.5	9/GR1	
USAPSA03	-175.20	21	-118.27	40.12	3.62	0.80	136	1	65.3	9/GR2	
USAWH101	-148.20	21	-109.65	38.13	5.53	1.95	142	1	62.3	10	
USAWH102	-157.20	21	-111.41	38.57	5.51	1.54	138	1	63.5	10	
VENAND03	-115.20	21	-67.04	6.91	2.37	1.43	111	1	67.6	9/GR5	10

1	2	3	4	5	6	7	8	9			
ALS00002	-165.80	22	-149.63	58.52	3.81	1.23	171	2	59.9	9/GR1	10
ALS00003	-174.80	22	-150.95	58.54	3.77	1.11	167	2	60.2	9/GR2	10
ARGNORT4	-93.80	22	-63.96	-30.01	3.86	1.99	48	2	66.0		
ARGNORT5	-54.80	22	-62.85	-29.80	3.24	2.89	47	2	63.8		
ATNBEAM1	-52.80	22	-66.44	14.87	1.83	0.80	39	2	61.3		
B CE311	-63.80	22	-40.60	-6.07	3.04	2.06	174	2	61.9	8 9/GR7	
B CE312	-44.80	22	-40.26	-6.06	3.44	2.09	174	2	61.2	8 9/GR9	10 11
B CE411	-63.80	22	-50.97	-15.26	3.86	1.38	49	2	62.9	8 9/GR7	
B CE412	-44.80	22	-50.71	-15.30	3.57	1.56	52	2	63.0	8 9/GR9	10 12
B CE511	-63.80	22	-53.11	-2.98	2.42	2.15	107	2	63.4	8 9/GR7	
B NO611	-73.80	22	-59.60	-11.62	2.86	1.69	165	1	63.1	8 9/GR8	
B NO711	-73.80	22	-60.70	-1.78	3.54	1.78	126	1	63.1	8 9/GR8	
B NO811	-73.80	22	-68.75	-4.71	2.37	1.65	73	1	63.1	8 9/GR8	
B SE911	-101.80	22	-45.99	-19.09	2.22	0.80	62	2	65.7	8	
B SU111	-80.80	22	-51.10	-25.64	2.76	1.06	50	1	63.1	8 9/GR6	
B SU112	-44.80	22	-50.76	-25.62	2.47	1.48	56	2	62.6	8 9/GR9	11
B SU211	-80.80	22	-44.51	-16.94	3.22	1.37	60	2	62.8	8 9/GR6	
B SU212	-44.80	22	-43.99	-16.97	3.27	1.92	59	2	61.6	8 9/GR9	12
BLZ00001	-115.80	22	-88.68	17.27	0.80	0.80	90	2	59.2		
CAN01101	-137.80	22	-125.60	57.24	3.45	1.27	157	2	59.7	9/GR10	10
CAN01201	-137.80	22	-111.92	55.89	3.33	0.98	151	2	59.8	9/GR10	10
CAN01202	-72.30	22	-107.64	55.62	2.75	1.11	32	2	59.8		
CAN01203	-128.80	22	-111.43	55.56	3.07	1.15	151	2	59.7	9/GR12	10
CAN01303	-128.80	22	-102.39	57.12	3.54	0.92	154	2	60.3	9/GR12	10
CAN01304	-90.80	22	-99.00	57.33	1.96	1.73	1	2	60.0	9/GR13	
CAN01403	-128.80	22	-89.70	52.02	4.67	0.80	148	2	62.1	9/GR12	10
CAN01404	-90.80	22	-84.78	52.41	3.09	2.06	153	2	60.6	9/GR13	
CAN01405	-81.80	22	-84.02	52.34	2.82	2.30	172	2	60.5	9/GR14	
CAN01504	-90.80	22	-72.68	53.78	3.57	1.67	157	2	60.4	9/GR13	
CAN01505	-81.80	22	-71.76	53.76	3.30	1.89	162	2	60.3	9/GR14	
CAN01605	-81.80	22	-61.54	49.50	2.66	1.39	144	2	60.5	9/GR14	
CAN01606	-70.30	22	-61.32	49.51	2.41	1.65	148	2	60.4		
CHLCONT4	-105.80	22	-69.59	-23.20	2.21	0.80	68	2	59.3	9/GR16	
CHLCONT6	-105.80	22	-73.52	-55.52	3.65	1.31	39	2	59.7	9/GR16	
CRBBAH01	-92.30	22	-76.09	24.13	1.83	0.80	141	1	61.9	9/GR18	
CRBBER01	-92.30	22	-64.76	32.13	0.80	0.80	90	1	56.9	9/GR18	
CRBBLZ01	-92.30	22	-88.61	17.26	0.80	0.80	90	1	58.9	9/GR18	
CRBEC001	-92.30	22	-60.07	8.26	4.20	0.86	115	1	64.6	9/GR18	
CRBJMC01	-92.30	22	-79.45	17.97	0.99	0.80	151	1	61.3	9/GR18	
CTR00201	-130.80	22	-84.33	9.67	0.82	0.80	119	2	66.0		
DMAIFRB1	-79.30	22	-61.30	15.35	0.80	0.80	90	2	58.7		
EQAC0001	-94.80	22	-78.31	-1.52	1.48	1.15	65	1	63.3	9/GR19	
EQAG0001	-94.80	22	-90.36	-0.57	0.94	0.89	99	1	61.2	9/GR19	
HWA00002	-165.80	22	-165.79	23.32	4.20	0.80	160	2	59.0	9/GR1	10
HWA00003	-174.80	22	-166.10	23.42	4.25	0.80	159	2	59.0	9/GR2	10
MEX01NTE	-77.80	22	-105.80	25.99	2.88	2.07	155	2	60.7	1	
MEX02NTE	-135.80	22	-107.36	26.32	3.80	1.57	149	2	61.4	1	10
MEX02SUR	-126.80	22	-96.39	19.88	3.19	1.87	158	2	62.8	1	10
NCG00003	-107.30	22	-84.99	12.90	1.05	1.01	176	1	63.6		
PRU00004	-85.80	22	-74.19	-8.39	3.74	2.45	112	2	63.1		
PTRVIR01	-100.80	22	-65.85	18.12	0.80	0.80	90	2	60.8	1 6 9/GR20	
PTRVIR02	-109.80	22	-65.85	18.12	0.80	0.80	90	2	61.4	1 6 9/GR21	
USAEH001	-61.30	22	-85.16	36.21	5.63	3.32	22	2	62.1	1 5 6	
USAEH002	-100.80	22	-89.28	36.16	5.65	3.78	170	2	62.0	1 6 9/GR20	10
USAEH003	-109.80	22	-90.12	36.11	5.55	3.56	161	2	62.3	1 6 9/GR21	10
USAEH004	-118.80	22	-91.16	36.05	5.38	3.24	153	2	62.9	1 5 6	10
USAPSA02	-165.80	22	-117.79	40.58	4.04	0.82	135	2	63.5	9/GR1	
USAPSA03	-174.80	22	-118.20	40.15	3.63	0.80	136	2	65.3	9/GR2	
USAWH101	-147.80	22	-109.70	38.13	5.52	1.96	142	2	62.3	10	
USAWH102	-156.80	22	-111.40	38.57	5.51	1.55	138	2	63.5	10	
VEN11VEN	-103.80	22	-66.79	6.90	2.50	1.77	122	2	65.5	10	

12 544.76 MHz (23)

1	2	3	4	5	6	7	8	9			
ALS00002	-166.20	23	-149.66	58.37	3.76	1.24	170	1	60.0	9/GR1	10
ALS00003	-175.20	23	-150.98	58.53	3.77	1.11	167	1	60.2	9/GR2	10
ARGINSU4	-94.20	23	-52.98	-59.81	3.40	0.80	19	1	60.1	9/GR3	
ARGINSU5	-55.20	23	-44.17	-59.91	3.77	0.80	13	1	59.5	9/GR4	
ARGSUR04	-94.20	23	-65.04	-43.33	3.32	1.50	40	1	60.9	9/GR3	
ARGSUR05	-55.20	23	-63.68	-43.01	2.54	2.38	152	1	60.9	9/GR4	
B CE311	-64.20	23	-40.60	-6.07	3.04	2.06	174	1	61.9	8/9/GR7	
B CE312	-45.20	23	-40.27	-6.06	3.44	2.09	174	1	61.3	8/9/GR9	1011
B CE411	-64.20	23	-50.97	-15.27	3.86	1.38	49	1	62.9	8/9/GR7	
B CE412	-45.20	23	-50.71	-15.30	3.57	1.56	52	1	63.1	8/9/GR9	1012
B CE511	-64.20	23	-53.10	-2.90	2.44	2.13	104	1	63.4	8/9/GR7	
B NO611	-74.20	23	-59.60	-11.62	2.85	1.69	165	2	63.2	8/9/GR8	
B NO711	-74.20	23	-60.70	-1.78	3.54	1.78	126	2	63.2	8/9/GR8	
B NO811	-74.20	23	-68.76	-4.71	2.37	1.65	73	2	63.1	8/9/GR8	
B SU111	-81.20	23	-51.12	-25.63	2.76	1.05	50	1	63.2	8/9/GR6	
B SU112	-45.20	23	-50.75	-25.62	2.47	1.48	56	1	62.6	8/9/GR9	11
B SU211	-81.20	23	-44.51	-16.95	3.22	1.36	60	1	62.8	8/9/GR6	
B SU212	-45.20	23	-44.00	-16.87	3.20	1.96	58	1	61.6	8/9/GR9	12
BERBERMU	-96.20	23	-64.77	32.32	0.80	0.80	90	2	57.0		
BOLAND01	-115.20	23	-65.04	-16.76	2.49	1.27	76	1	68.1	9/GR5	
BOL00001	-87.20	23	-64.61	-16.71	2.52	2.19	85	1	64.2		
BRB00001	-92.70	23	-59.85	12.93	0.80	0.80	90	2	59.4		
CAN01101	-138.20	23	-125.63	57.24	3.45	1.27	157	1	59.7	9/GR10	10
CAN01201	-138.20	23	-112.04	55.95	3.35	0.97	151	1	59.8	9/GR10	10
CAN01202	-72.70	23	-107.70	55.63	2.74	1.12	32	1	59.8		
CAN01203	-129.20	23	-111.48	55.61	3.08	1.15	151	1	59.7	9/GR12	10
CAN01303	-129.20	23	-102.42	57.12	3.54	0.91	154	1	60.3	9/GR12	10
CAN01304	-91.20	23	-99.12	57.36	1.98	1.72	2	1	60.1	9/GR13	
CAN01403	-129.20	23	-89.75	52.02	4.68	0.80	148	1	62.1	9/GR12	10
CAN01404	-91.20	23	-84.82	52.42	3.10	2.05	152	1	60.6	9/GR13	
CAN01405	-82.20	23	-84.00	52.39	2.84	2.29	172	1	60.5	9/GR14	
CAN01504	-91.20	23	-72.66	53.77	3.57	1.67	156	1	60.4	9/GR13	
CAN01505	-82.20	23	-71.77	53.79	3.30	1.89	162	1	60.4	9/GR14	
CAN01605	-82.20	23	-61.50	49.55	2.65	1.40	143	1	60.5	9/GR14	
CAN01606	-70.70	23	-61.30	49.55	2.40	1.65	148	1	60.5		
CHLCONT5	-106.20	23	-72.23	-35.57	2.60	0.80	55	1	59.6	9/GR17	
CHLPAC02	-106.20	23	-80.06	-30.06	1.36	0.80	69	1	59.4	9/GR17	
CLMAND01	-115.20	23	-74.72	5.93	3.85	1.63	114	1	65.4	9/GR5	10
CLM00001	-103.20	23	-74.50	5.87	3.98	1.96	118	1	63.9	10	
CUB00001	-89.20	23	-79.81	21.62	2.24	0.80	168	1	61.3		
EQACAND1	-115.20	23	-78.40	-1.61	1.37	0.95	75	1	64.4	9/GR5	
EQAGAND1	-115.20	23	-90.34	-0.62	0.90	0.81	89	1	61.6	9/GR5	
GRD00059	-57.20	23	-61.58	12.29	0.80	0.80	90	1	58.7		
GRLDNK01	-53.20	23	-44.89	66.56	2.70	0.82	173	1	60.2	2	
GUY00201	-84.70	23	-59.19	4.78	1.44	0.85	95	1	63.8		
HWA00002	-166.20	23	-165.79	23.42	4.20	0.80	160	1	59.0	9/GR1	10
HWA00003	-175.20	23	-166.10	23.42	4.25	0.80	159	1	59.0	9/GR2	10
MEX01INTE	-78.20	23	-105.81	26.01	2.89	2.08	155	1	60.8	1	
MEX01SUR	-69.20	23	-94.84	19.82	3.05	2.09	4	1	62.5	1	
MEX02NTE	-136.20	23	-107.21	26.31	3.84	1.55	148	1	61.5	1	10
MEX02SUR	-127.20	23	-96.39	19.88	3.18	1.87	157	1	62.8	1	10
MSR00001	-79.70	23	-61.73	16.75	0.80	0.80	90	1	58.9	4	
PAQAC01	-106.20	23	-109.18	-27.53	0.80	0.80	90	1	56.4	9/GR17	
PRG00002	-99.20	23	-58.66	-23.32	1.45	1.04	76	1	60.5		
PRUAND02	-115.20	23	-74.69	-8.39	3.41	1.79	95	1	64.3	9/GR5	
PTRVIR01	-101.20	23	-65.85	18.12	0.80	0.80	90	1	60.8	1 6 9/GR20	
PTRVIR02	-110.20	23	-65.86	18.12	0.80	0.80	90	1	61.3	1 6 9/GR21	
URG00001	-71.70	23	-56.22	-32.52	1.02	0.89	11	1	60.2		
USAEH001	-61.70	23	-85.19	36.21	5.63	3.33	22	1	62.1	1 5 6	
USAEH002	-101.20	23	-89.24	36.16	5.67	3.76	170	1	62.0	1 6 9/GR20	10
USAEH003	-110.20	23	-90.14	36.11	5.55	3.55	161	1	62.4	1 6 9/GR21	10
USAEH004	-119.20	23	-91.16	36.05	5.38	3.24	152	1	62.9	1 5 6	10
USAPSA02	-166.20	23	-117.80	40.58	4.03	0.82	135	1	63.6	9/GR1	
USAPSA03	-175.20	23	-118.27	40.12	3.62	0.80	136	1	65.4	9/GR2	
USAWH101	-148.20	23	-109.65	38.13	5.53	1.95	142	1	62.4	10	
USAWH102	-157.20	23	-111.41	38.57	5.51	1.54	138	1	63.5	10	
VENAND03	-115.20	23	-67.04	6.91	2.37	1.43	111	1	67.7	9/GR5	10

1	2	3	4	5	6	7	8	9			
ALS00002	-165.80	24	-149.63	58.52	3.81	1.23	171	2	59.9	9/GR1	10
ALS00003	-174.80	24	-150.95	58.54	3.77	1.11	167	2	60.2	9/GR2	10
ARGNORT4	-93.80	24	-63.96	-30.01	3.86	1.99	48	2	66.1		
ARGNORT5	-54.80	24	-62.85	-29.80	3.24	2.89	47	2	63.9		
B CE311	-63.80	24	-40.60	-6.07	3.04	2.06	174	2	61.9	8 9/GR7	
B CE312	-44.80	24	-40.26	-6.06	3.44	2.09	174	2	61.3	8 9/GR9	10 11
B CE411	-63.80	24	-50.97	-15.26	3.86	1.38	49	2	62.9	8 9/GR7	
B CE412	-44.80	24	-50.71	-15.30	3.57	1.56	52	2	63.1	8 9/GR9	10 12
B CE511	-63.80	24	-53.11	-2.98	2.42	2.15	107	2	63.4	8 9/GR7	
B NO611	-73.80	24	-59.60	-11.62	2.86	1.69	165	1	63.2	8 9/GR8	
B NO711	-73.80	24	-60.70	-1.78	3.54	1.78	126	1	63.2	8 9/GR8	
B NO811	-73.80	24	-68.75	-4.71	2.37	1.65	73	1	63.2	8 9/GR8	
B SE911	-101.80	24	-45.99	-19.09	2.22	0.80	62	2	65.7	8	
B SU111	-80.80	24	-51.10	-25.64	2.76	1.06	50	2	63.2	8 9/GR6	
B SU112	-44.80	24	-50.76	-25.62	2.47	1.48	56	2	62.6	8 9/GR9	11
B SU211	-80.80	24	-44.51	-16.94	3.22	1.37	60	2	62.8	8 9/GR6	
B SU212	-44.80	24	-43.99	-16.97	3.27	1.92	59	2	61.6	8 9/GR9	12
CAN01101	-137.80	24	-125.60	57.24	3.45	1.27	157	2	59.7	9/GR10	10
CAN01201	-137.80	24	-111.92	55.89	3.33	0.98	151	2	59.8	9/GR10	10
CAN01202	-72.30	24	-107.64	55.62	2.75	1.11	32	2	59.8		
CAN01203	-128.80	24	-111.43	55.56	3.07	1.15	151	2	59.7	9/GR12	10
CAN01303	-128.80	24	-102.39	57.12	3.54	0.92	154	2	60.3	9/GR12	10
CAN01304	-90.80	24	-99.00	57.33	1.96	1.73	1	2	60.0	9/GR13	
CAN01403	-128.80	24	-89.70	52.02	4.67	0.80	148	2	62.1	9/GR12	10
CAN01404	-90.80	24	-84.78	52.41	3.09	2.06	153	2	60.6	9/GR13	
CAN01405	-81.80	24	-84.02	52.34	2.82	2.30	172	2	60.5	9/GR14	
CAN01504	-90.80	24	-72.68	53.78	3.57	1.67	157	2	60.4	9/GR13	
CAN01505	-81.80	24	-71.76	53.76	3.30	1.89	162	2	60.4	9/GR14	
CAN01605	-81.80	24	-61.54	49.50	2.66	1.39	144	2	60.5	9/GR14	
CAN01606	-70.30	24	-61.32	49.51	2.41	1.65	148	2	60.5		
CHLCONT4	-105.80	24	-69.59	-23.20	2.21	0.80	68	2	59.3	9/GR16	
CHLCONT6	-105.80	24	-73.52	-55.52	3.65	1.31	39	2	59.8	9/GR16	
CRBBAH01	-92.30	24	-76.09	24.13	1.83	0.80	141	1	62.0	9/GR18	
CRBBER01	-92.30	24	-64.76	32.13	0.80	0.80	90	1	57.0	9/GR18	
CRBBLZ01	-92.30	24	-88.61	17.26	0.80	0.80	90	1	58.9	9/GR18	
CRBEC001	-92.30	24	-60.07	8.26	4.20	0.86	115	1	64.6	9/GR18	
CRBJMC01	-92.30	24	-79.45	17.97	0.99	0.80	151	1	61.4	9/GR18	
EQAC0001	-94.80	24	-78.31	-1.52	1.48	1.15	65	1	63.3	9/GR19	
EQAG0001	-94.80	24	-90.36	-0.57	0.94	0.89	99	1	61.3	9/GR19	
GRD00003	-79.30	24	-61.62	12.34	0.80	0.80	90	2	58.9		
GTMIFRB2	-107.30	24	-90.50	15.64	1.03	0.80	84	1	61.4		
GUFMGG02	-52.80	24	-56.42	8.47	4.16	0.81	123	2	63.0	2 7	
HWA00002	-165.80	24	-165.79	23.32	4.20	0.80	160	2	59.0	9/GR1	10
HWA00003	-174.80	24	-166.10	23.42	4.25	0.80	159	2	59.0	9/GR2	10
MEX01NTE	-77.80	24	-105.80	25.99	2.88	2.07	155	2	60.8	1	
MEX02NTE	-135.80	24	-107.36	26.32	3.80	1.57	149	2	61.5	1	10
MEX02SUR	-126.80	24	-96.39	19.88	3.19	1.87	158	2	62.8	1	10
PNRIFRB2	-121.00	24	-80.15	8.46	1.01	0.80	170	1	65.1		
PRU00004	-85.80	24	-74.19	-8.39	3.74	2.45	112	2	63.2		
PTRVIR01	-100.80	24	-65.85	18.12	0.80	0.80	90	2	60.9	1 6 9/GR20	
PTRVIR02	-109.80	24	-65.85	18.12	0.80	0.80	90	2	61.4	1 6 9/GR21	
USAEH001	-61.30	24	-85.16	36.21	5.63	3.32	22	2	62.1	1 5 6	
USAEH002	-100.80	24	-89.28	36.16	5.65	3.78	170	2	62.0	1 6 9/GR20	10
USAEH003	-109.80	24	-90.12	36.11	5.55	3.56	161	2	62.4	1 6 9/GR21	10
USAEH004	-118.80	24	-91.16	36.05	5.38	3.24	153	2	62.9	1 5 6	10
USAPSA02	-165.80	24	-117.79	40.58	4.04	0.82	135	2	63.6	9/GR1	
USAPSA03	-174.80	24	-118.20	40.15	3.63	0.80	136	2	65.3	9/GR2	
USAWH101	-147.80	24	-109.70	38.13	5.52	1.96	142	2	62.4	10	
USAWH102	-156.80	24	-111.40	38.57	5.51	1.55	138	2	63.5	10	
VEN02VEN	-103.80	24	-63.50	15.50	0.80	0.80	90	2	60.1	9/GR22	
VEN11VEN	-103.80	24	-66.79	6.90	2.50	1.77	122	2	65.6	9/GR22	10

12 573.92 MHz (25)

1	2	3	4	5	6	7	8	9			
ALS00002	-166.20	25	-149.66	58.37	3.76	1.24	170	1	59.9	9/GR1	10
ALS00003	-175.20	25	-150.98	58.53	3.77	1.11	167	1	60.2	9/GR2	10
ARGINSU4	-94.20	25	-52.98	-59.81	3.40	0.80	19	1	60.1	9/GR3	
ARGINSU5	-55.20	25	-44.17	-59.91	3.77	0.80	13	1	59.5	9/GR4	
ARGSUR04	-94.20	25	-65.04	-43.33	3.32	1.50	40	1	60.9	9/GR3	
ARGSUR05	-55.20	25	-63.68	-43.01	2.54	2.38	152	1	60.2	9/GR4	
B CE311	-64.20	25	-40.60	-6.07	3.04	2.06	174	1	61.9	8/9/GR7	
B CE312	-45.20	25	-40.27	-6.06	3.44	2.09	174	1	61.2	8/9/GR9	10 11
B CE411	-64.20	25	-50.97	-15.27	3.86	1.38	49	1	62.9	8/9/GR7	
B CE412	-45.20	25	-50.71	-15.30	3.57	1.56	52	1	63.0	8/9/GR9	10 12
B CE511	-64.20	25	-53.10	-2.90	2.44	2.13	104	1	63.4	8/9/GR7	
B NO611	-74.20	25	-59.60	-11.62	2.85	1.69	165	2	63.1	8/9/GR8	
B NO711	-74.20	25	-60.70	-1.78	3.54	1.78	126	2	63.1	8/9/GR8	
B NO811	-74.20	25	-68.76	-4.71	2.37	1.65	73	2	63.1	8/9/GR8	
B SU111	-81.20	25	-51.12	-25.63	2.76	1.05	50	1	63.2	8/9/GR6	
B SU112	-45.20	25	-50.75	-25.62	2.47	1.48	56	1	62.5	8/9/GR9	11
B SU211	-81.20	25	-44.51	-16.95	3.22	1.36	60	1	62.8	8/9/GR6	
B SU212	-45.20	25	-44.00	-16.87	3.20	1.96	58	1	61.6	8/9/GR9	12
BERBERMU	-96.20	25	-64.77	32.32	0.80	0.80	90	2	57.0		
BOLAND01	-115.20	25	-65.04	-16.76	2.49	1.27	76	1	68.0	9/GR5	
CAN01101	-138.20	25	-125.63	57.24	3.45	1.27	157	1	59.7	9/GR10	10
CAN01201	-138.20	25	-112.04	55.95	3.35	0.97	151	1	59.8	9/GR10	10
CAN01202	-72.70	25	-107.70	55.63	2.74	1.12	32	1	59.8		
CAN01203	-129.20	25	-111.48	55.61	3.08	1.15	151	1	59.7	9/GR12	10
CAN01303	-129.20	25	-102.42	57.12	3.54	0.91	154	1	60.2	9/GR12	10
CAN01304	-91.20	25	-99.12	57.36	1.98	1.72	2	1	60.0	9/GR13	
CAN01403	-129.20	25	-89.75	52.02	4.68	0.80	148	1	62.1	9/GR12	10
CAN01404	-91.20	25	-84.82	52.42	3.10	2.05	152	1	60.6	9/GR13	
CAN01405	-82.20	25	-84.00	52.39	2.84	2.29	172	1	60.5	9/GR14	
CAN01504	-91.20	25	-72.66	53.77	3.57	1.67	156	1	60.4	9/GR13	
CAN01505	-82.20	25	-71.77	53.79	3.30	1.89	162	1	60.3	9/GR14	
CAN01605	-82.20	25	-61.50	49.55	2.65	1.40	143	1	60.5	9/GR14	
CAN01606	-70.70	25	-61.30	49.55	2.40	1.65	148	1	60.4		
CHLCONT5	-106.20	25	-72.23	-35.57	2.60	0.80	55	1	59.6	9/GR17	
CHLPAC02	-106.20	25	-80.06	-30.06	1.36	0.80	69	1	59.4	9/GR17	
CLMAND01	-115.20	25	-74.72	5.93	3.85	1.63	114	1	65.3	9/GR5	10
CLM00001	-103.20	25	-74.50	5.87	3.98	1.96	118	1	63.9	10	
EQACAND1	-115.20	25	-78.40	-1.61	1.37	0.95	75	1	64.4	9/GR5	
EQAGAND1	-115.20	25	-90.34	-0.62	1.90	0.81	89	1	61.5	9/GR5	
HWA00002	-166.20	25	-165.79	23.42	4.20	0.80	160	1	59.0	9/GR1	10
HWA00003	-175.20	25	-166.10	23.42	4.25	0.80	159	1	58.9	9/GR2	10
JMC00002	-92.70	25	-77.30	18.12	0.80	0.80	90	2	60.1		
KNA00001	-79.70	25	-62.46	17.44	0.80	0.80	90	1	58.6		
MEX01NTE	-78.20	25	-105.81	26.01	2.89	2.08	155	1	60.7	1	
MEX01SUR	-69.20	25	-94.84	19.82	3.05	2.09	4	1	62.5	1	
MEX02NTE	-136.20	25	-107.21	26.31	3.84	1.55	148	1	61.4	1	10
MEX02SUR	-127.20	25	-96.39	19.88	3.18	1.87	157	1	62.8	1	10
PAQPAC01	-106.20	25	-109.18	-27.53	0.80	0.80	90	1	56.4	9/GR17	
PRG00002	-99.20	25	-58.66	-23.32	1.45	1.04	76	1	60.4		
PRUAND02	-115.20	25	-74.69	-8.39	3.41	1.79	95	1	64.3	9/GR5	
PTRVIR01	-101.20	25	-65.85	18.12	0.80	0.80	90	1	60.8	1 6 9/GR20	
PTRVIR02	-110.20	25	-65.86	18.12	0.80	0.80	90	1	61.3	1 6 9/GR21	
SPMFRAN3	-53.20	25	-67.24	47.51	3.16	0.80	7	1	60.6	2 7	
SURINAM2	-84.70	25	-55.69	4.35	1.00	0.80	86	1	63.5		
URG00001	-71.70	25	-56.22	-32.52	1.02	0.89	11	1	60.2		
USAEH001	-61.70	25	-85.19	36.21	5.63	3.33	22	1	62.1	1 5 6	
USAEH002	-101.20	25	-89.24	36.16	5.67	3.76	170	1	62.0	1 6 9/GR20	10
USAEH003	-110.20	25	-90.14	36.11	5.55	3.55	161	1	62.3	1 6 9/GR21	10
USAEH004	-119.20	25	-91.16	36.05	5.38	3.24	152	1	62.9	1 5 6	10
USAPSA02	-166.20	25	-117.80	40.58	4.03	0.82	135	1	63.5	9/GR1	
USAPSA03	-175.20	25	-118.27	40.12	3.62	0.80	136	1	65.3	9/GR2	
USAWH101	-148.20	25	-109.65	38.13	5.53	1.95	142	1	62.3	10	
USAWH102	-157.20	25	-111.41	38.57	5.51	1.54	138	1	63.5	10	
VENAND03	-115.20	25	-67.04	6.91	2.37	1.43	111	1	67.6	9/GR5	10



1	2	3	4	5	6	7	8	9			
ALS00002	-165.80	26	-149.63	58.52	3.81	1.23	171	2	59.9	9/GR1	10
ALS00003	-174.80	26	-150.95	58.54	3.77	1.11	167	2	60.2	9/GR2	10
ARGNORT4	-93.80	26	-63.96	-30.01	3.86	1.99	48	2	66.0		
ARGNORT5	-54.80	26	-62.85	-29.80	3.24	2.89	47	2	63.8		
ATNBEAM1	-52.80	26	-66.44	14.87	1.83	0.80	39	2	61.3		
B CE311	-63.80	26	-40.60	-6.07	3.04	2.06	174	2	61.9	8/GR7	
B CE312	-44.80	26	-40.26	-6.06	3.44	2.09	174	2	61.2	8/GR9	10 11
B CE411	-63.80	26	-50.97	-15.26	3.86	1.38	49	2	62.9	8/GR7	
B CE412	-44.80	26	-50.71	-15.30	3.57	1.56	52	2	63.0	8/GR9	10 12
B CE511	-63.80	26	-53.11	-2.98	2.42	2.15	107	2	63.4	8/GR7	
B NO611	-73.80	26	-59.60	-11.62	2.86	1.69	165	1	63.1	8/GR8	
B NO711	-73.80	26	-60.70	-1.78	3.54	1.78	126	1	63.1	8/GR8	
B NO811	-73.80	26	-68.75	-4.71	2.37	1.65	73	1	63.1	8/GR8	
B SE911	-101.80	26	-45.99	-19.09	2.22	0.80	62	2	65.7	8	
B SU111	-80.80	26	-51.10	-23.64	2.76	1.06	50	2	63.1	8/GR6	
B SU112	-44.80	26	-50.76	-25.62	2.47	1.48	56	2	62.6	8/GR9	11
B SU211	-80.80	26	-44.51	-16.94	3.22	1.37	60	2	62.8	8/GR6	
B SU212	-44.80	26	-43.99	-16.97	3.27	1.92	59	2	61.6	8/GR9	12
BLZ00001	-115.80	26	-88.68	17.27	0.80	0.80	90	2	59.2		
CAN01101	-137.80	26	-125.60	57.24	3.45	1.27	157	2	59.7	9/GR10	10
CAN01201	-137.80	26	-111.92	55.89	3.33	0.98	151	2	59.8	9/GR10	10
CAN01202	-72.30	26	-107.64	55.62	2.75	1.11	32	2	59.8		
CAN01203	-128.80	26	-111.43	55.56	3.07	1.15	151	2	59.7	9/GR12	10
CAN01303	-128.80	26	-102.39	57.12	3.54	0.92	154	2	60.3	9/GR12	10
CAN01304	-90.80	26	-99.00	57.33	1.96	1.73	1	2	60.0	9/GR13	
CAN01403	-128.80	26	-89.70	52.02	4.67	0.80	148	2	62.1	9/GR13	10
CAN01404	-90.80	26	-84.78	52.41	3.09	2.06	153	2	60.6	9/GR13	
CAN01405	-81.80	26	-84.02	52.34	2.82	2.30	172	2	60.5	9/GR14	
CAN01504	-90.80	26	-72.68	53.78	3.57	1.67	157	2	60.4	9/GR13	
CAN01505	-81.80	26	-71.76	53.76	3.30	1.89	162	2	60.3	9/GR14	
CAN01605	-81.80	26	-61.54	49.50	2.66	1.39	144	2	60.5	9/GR14	
CAN01606	-70.30	26	-61.32	49.51	2.41	1.65	148	2	60.4		
CHLCONT4	-105.80	26	-69.59	-23.20	2.21	0.80	68	2	59.3	9/GR16	
CHLCONT6	-105.80	26	-73.52	-55.52	3.65	1.31	39	2	59.7	9/GR16	
CRBBAH01	-92.30	26	-76.09	24.13	1.83	0.80	141	1	61.9	9/GR18	
CRBBER01	-92.30	26	-64.76	32.13	0.80	0.80	90	1	56.9	9/GR18	
CRBBELZ01	-92.30	26	-88.61	17.26	0.80	0.80	90	1	58.9	9/GR18	
CRBEC001	-92.30	26	-60.07	8.26	4.20	0.86	115	1	64.6	9/GR18	
CRBJMC01	-92.30	26	-79.45	17.97	0.99	0.80	151	1	61.3	9/GR18	
CTR00201	-130.80	26	-84.33	9.67	0.82	0.80	119	2	66.0		
DMAIFRB1	-79.30	26	-61.30	15.35	0.80	0.80	90	2	58.7		
EQAC0001	-94.80	26	-78.31	-1.52	1.48	1.15	65	1	63.3	9/GR19	
EQAG0001	-94.80	26	-90.36	-0.57	0.94	0.89	99	1	61.2	9/GR19	
HWA00002	-165.80	26	-165.79	23.32	4.20	0.80	160	2	59.0	9/GR1	10
HWA00003	-174.80	26	-166.10	23.42	4.25	0.80	159	2	59.0	9/GR2	10
MEX01NTE	-77.80	26	-105.80	25.99	2.88	2.07	155	2	60.7	1	
MEX02NTE	-135.80	26	-107.36	26.32	3.80	1.57	149	2	61.4	1	10
MEX02SUR	-126.80	26	-96.39	19.88	3.19	1.87	158	2	62.8	1	10
NCG00003	-107.30	26	-84.99	12.90	1.05	1.01	176	1	63.6		
PRU00004	-85.80	26	-74.19	-8.39	3.74	2.45	112	2	63.1		
PTRVIR01	-100.80	26	-65.85	18.12	0.80	0.80	90	2	60.8	1 6 9/GR20	
PTRVIR02	-109.80	26	-65.85	18.12	0.80	0.80	90	2	61.4	1 6 9/GR21	
USAEH001	-61.30	26	-85.16	36.21	5.63	3.32	22	2	62.1	1 5 6	
USAEH002	-100.80	26	-89.28	36.16	5.65	3.78	170	2	62.0	1 6 9/GR20	10
USAEH003	-109.80	26	-90.12	36.11	5.55	3.56	161	2	62.3	1 6 9/GR21	10
USAEH004	-118.80	26	-91.16	36.05	5.38	3.24	153	2	62.9	1 5 6	10
USAPSA02	-165.80	26	-117.79	40.58	4.04	0.82	135	2	63.5	9/GR1	
USAPSA03	-174.80	26	-118.20	40.15	3.63	0.80	136	2	65.3	9/GR2	
USAWH01	-147.80	26	-109.70	38.13	5.52	1.96	142	2	62.3	10	
USAWH02	-156.80	26	-111.40	38.57	5.51	1.55	138	2	63.5	10	
VEN11VEN	-103.80	26	-66.79	6.90	2.50	1.77	122	2	65.5	10	

12 603.08 MHz (27)

1	2	3	4		5		6	7	8	9	
ALS00002	-166.20	27	-149.66	58.37	3.76	1.24	170	1	60.0	9/GR1	10
ALS00003	-175.20	27	-150.98	58.53	3.77	1.11	167	1	60.2	9/GR2	10
ARGINSU4	-94.20	27	-52.98	-59.81	3.40	0.80	19	1	60.1	9/GR3	
ARGINSU5	-55.20	27	-44.17	-59.91	3.77	0.80	13	1	59.5	9/GR4	
ARGSUR04	-94.20	27	-65.04	-43.33	3.32	1.50	40	1	60.9	9/GR3	
ARGSUR05	-55.20	27	-63.68	-43.01	2.54	2.38	152	1	60.3	9/GR4	
B CE311	-64.20	27	-40.60	-6.07	3.04	2.06	174	1	61.9	8 9/GR7	
B CE312	-45.20	27	-40.27	-6.06	3.44	2.09	174	1	61.3	8 9/GR9	10 11
B CE411	-64.20	27	-50.97	-15.27	3.86	1.38	49	1	62.9	8 9/GR7	
B CE412	-45.20	27	-50.71	-15.30	3.57	1.56	52	1	63.1	8 9/GR9	10 12
B CE511	-64.20	27	-53.10	-2.90	2.44	2.13	104	1	63.4	8 9/GR7	
B NO611	-74.20	27	-59.60	-11.62	2.85	1.69	165	2	63.2	8 9/GR8	
B NO711	-74.20	27	-60.70	-1.78	3.54	1.78	126	2	63.2	8 9/GR8	
B NO811	-74.20	27	-68.76	-4.71	2.37	1.65	73	2	63.1	8 9/GR8	
B SU111	-81.20	27	-51.12	-25.63	2.76	1.05	50	1	63.2	8 9/GR6	
B SU112	-45.20	27	-50.75	-25.62	2.47	1.48	56	1	62.6	8 9/GR9	11
B SU211	-81.20	27	-44.51	-16.95	3.22	1.36	60	1	62.8	8 9/GR6	
B SU212	-45.20	27	-44.00	-16.87	3.20	1.96	58	1	61.6	8 9/GR9	12
BERBERMU	-96.20	27	-64.77	32.32	0.80	0.80	90	2	57.0		
BOLAND01	-115.20	27	-65.04	-16.76	2.49	1.27	76	1	68.1	9/GR5	
BOL00001	-87.20	27	-64.61	-16.71	2.52	2.19	85	1	64.2		
BRB00001	-92.70	27	-59.85	12.93	0.80	0.80	90	2	59.4		
CAN01101	-138.20	27	-125.63	57.24	3.45	1.27	157	1	59.7	9/GR10	10
CAN01201	-138.20	27	-112.04	55.95	3.35	0.97	151	1	59.8	9/GR10	10
CAN01202	-72.70	27	-107.70	55.63	2.74	1.12	32	1	59.8		
CAN01203	-129.20	27	-111.48	55.61	3.08	1.15	151	1	59.7	9/GR12	10
CAN01303	-129.20	27	-102.42	57.12	3.54	0.91	154	1	60.3	9/GR12	10
CAN01304	-91.20	27	-99.12	57.36	1.98	1.72	2	1	60.1	9/GR13	
CAN01403	-129.20	27	-89.75	52.02	4.68	0.80	148	1	62.1	9/GR12	10
CAN01404	-91.20	27	-84.82	52.42	3.10	2.05	152	1	60.6	9/GR13	
CAN01405	-82.20	27	-84.00	52.39	2.84	2.29	172	1	60.5	9/GR14	
CAN01504	-91.20	27	-72.66	53.77	3.57	1.67	156	1	60.4	9/GR13	
CAN01505	-82.20	27	-71.77	53.79	3.30	1.89	162	1	60.4	9/GR14	
CAN01605	-82.20	27	-61.50	49.55	2.65	1.40	143	1	60.5	9/GR14	
CAN01606	-70.70	27	-61.30	49.55	2.40	1.65	148	1	60.5		
CHLCONT5	-106.20	27	-72.23	-35.57	2.60	0.80	55	1	59.6	9/GR17	
CHLPAC02	-106.20	27	-80.06	-30.06	1.36	0.80	69	1	59.4	9/GR17	
CLMAND01	-115.20	27	-74.72	5.93	3.85	1.63	114	1	65.4	9/GR5	10
CLM00001	-103.20	27	-74.50	5.87	3.98	1.96	118	1	63.9	10	
CUB00001	-89.20	27	-79.81	21.62	2.24	0.80	168	1	61.3		
EQACAND1	-115.20	27	-78.40	-1.61	1.37	0.95	75	1	64.4	9/GR5	
EQAGAND1	-115.20	27	-90.34	-0.62	0.90	0.81	89	1	61.6	9/GR5	
GRD00059	-57.20	27	-61.58	12.29	0.80	0.80	90	1	58.7		
GRLDNK01	-53.20	27	-44.89	66.56	2.70	0.82	173	1	60.2	2	
GUY00201	-84.70	27	-59.19	4.78	1.44	0.85	95	1	63.8		
HWA00002	-166.20	27	-165.79	23.42	4.20	0.80	160	1	59.0	9/GR1	10
HWA00003	-175.20	27	-166.10	23.42	4.25	0.80	159	1	59.0	9/GR2	10
MEX01INTE	-78.20	27	-105.81	26.01	2.89	2.08	155	1	60.8	1	
MEX01SUR	-69.20	27	-94.84	19.82	3.05	2.09	4	1	62.5	1	
MEX02NTE	-136.20	27	-107.21	26.31	3.84	1.55	148	1	61.5	1	10
MEX02SUR	-127.20	27	-96.39	19.88	3.18	1.87	157	1	62.8	1	10
MSR00001	-79.70	27	-61.73	16.75	0.80	0.80	90	1	58.9	4	
PAQPAC01	-106.20	27	-109.18	-27.53	0.80	0.80	90	1	56.4	9/GR17	
PRG00002	-99.20	27	-58.66	-23.32	1.45	1.04	76	1	60.5		
PRUAND02	-115.20	27	-74.69	-8.39	3.41	1.79	95	1	64.3	9/GR5	
PTRVIR01	-101.20	27	-65.85	18.12	0.80	0.80	90	1	60.8	1 6 9/GR20	
PTRVIR02	-110.20	27	-65.86	18.12	0.80	0.80	90	1	61.3	1 6 9/GR21	
URG00001	-71.70	27	-56.22	-32.52	1.02	0.89	11	1	60.2		
USAEH001	-61.70	27	-85.19	36.21	5.63	3.33	22	1	62.1	1 5 6	
USAEH002	-101.20	27	-89.24	36.16	5.67	3.76	170	1	62.0	1 6 9/GR20	10
USAEH003	-110.20	27	-90.14	36.11	5.55	3.55	161	1	62.4	1 6 9/GR21	10
USAEH004	-119.20	27	-91.16	36.05	5.38	3.24	152	1	62.9	1 5 6	10
USAPSA02	-166.20	27	-117.80	40.58	4.03	0.82	135	1	63.6	9/GR1	
USAPSA03	-175.20	27	-118.27	40.12	3.62	0.80	136	1	65.4	9/GR2	
USAWH101	-148.20	27	-109.65	38.13	5.53	1.95	142	1	62.4	10	
USAWH102	-157.20	27	-111.41	38.57	5.51	1.54	138	1	63.5	10	
VENAND03	-115.20	27	-67.04	6.91	2.37	1.43	111	1	67.7	9/GR5	10

1	2	3	4	5	6	7	8	9			
ALS00002	-165.80	28	-149.63	58.52	3.81	1.23	171	2	59.9	9/GR1	10
ALS00003	-174.80	28	-150.95	58.54	3.77	1.11	167	2	60.2	9/GR2	10
ARGNORT4	-93.80	28	-63.96	-30.01	3.86	1.99	48	2	66.1		
ARGNORT5	-54.80	28	-62.85	-29.80	3.24	2.89	47	2	63.9		
B CE311	-63.80	28	-40.60	-6.07	3.04	2.06	174	2	61.9	8/GR7	
B CE312	-44.80	28	-40.26	-6.06	3.44	2.09	174	2	61.3	8/GR9	10 11
B CE411	-63.80	28	-50.97	-15.26	3.86	1.38	49	2	62.9	8/GR7	
B CE412	-44.80	28	-50.71	-15.30	3.57	1.56	52	2	63.1	8/GR9	10 12
B CE511	-63.80	28	-53.11	-2.98	2.42	2.15	107	2	63.4	8/GR7	
B NO611	-73.80	28	-59.60	-11.62	2.86	1.69	165	1	63.2	8/GR8	
B NO711	-73.80	28	-60.70	-1.78	3.54	1.78	126	1	63.2	8/GR8	
B NO811	-73.80	28	-68.75	-4.71	2.37	1.65	73	1	63.2	8/GR8	
B SE911	-101.80	28	-45.99	-19.09	2.22	0.80	62	2	65.7	8	
B SU111	-80.80	28	-51.10	-25.64	2.76	1.06	50	2	63.2	8/GR6	
B SU112	-44.80	28	-50.76	-25.62	2.47	1.48	56	2	62.6	8/GR9	11
B SU211	-80.80	28	-44.51	-16.94	3.22	1.37	60	2	62.8	8/GR6	
B SU212	-44.80	28	-43.99	-16.97	3.27	1.92	59	2	61.6	8/GR9	12
CAN01101	-137.80	28	-125.60	57.24	3.45	1.27	157	2	59.7	9/GR10	10
CAN01201	-137.80	28	-111.92	55.89	3.33	0.98	151	2	59.8	9/GR10	10
CAN01202	-72.30	28	-107.64	55.62	2.75	1.11	32	2	59.8		
CAN01203	-128.80	28	-111.43	55.56	3.07	1.15	151	2	59.7	9/GR12	10
CAN01303	-128.80	28	-102.39	57.12	3.54	0.92	154	2	60.3	9/GR12	10
CAN01304	-90.80	28	-99.00	57.33	1.96	1.73	1	2	60.0	9/GR13	
CAN01403	-128.80	28	-89.70	52.02	4.67	0.80	148	2	62.1	9/GR12	10
CAN01404	-90.80	28	-84.78	52.41	3.09	2.06	153	2	60.6	9/GR13	
CAN01405	-81.80	28	-84.02	52.34	2.82	2.30	172	2	60.5	9/GR14	
CAN01504	-90.80	28	-72.68	53.78	3.57	1.67	157	2	60.4	9/GR13	
CAN01505	-81.80	28	-71.76	53.76	3.30	1.89	162	2	60.4	9/GR14	
CAN01605	-81.80	28	-61.54	49.50	2.66	1.39	144	2	60.5	9/GR14	
CAN01606	-70.30	28	-61.32	49.51	2.41	1.65	148	2	60.5		
CHLCONT4	-105.80	28	-69.59	-23.20	2.21	0.80	68	2	59.3	9/GR16	
CHLCONT6	-105.80	28	-73.52	-55.52	3.65	1.31	39	2	59.8	9/GR16	
CRBBAH01	-92.30	28	-76.09	24.13	1.83	0.80	141	1	62.0	9/GR18	
CRBBER01	-92.30	28	-64.76	32.13	0.80	0.80	90	1	57.0	9/GR18	
CRBBLZ01	-92.30	28	-88.61	17.26	0.80	0.80	90	1	58.9	9/GR18	
CRBEC001	-92.30	28	-60.07	8.26	4.20	0.86	115	1	64.6	9/GR18	
CRBJMC01	-92.30	28	-79.45	17.97	0.99	0.80	151	1	61.4	9/GR18	
EQAC0001	-94.80	28	-78.31	-1.52	1.48	1.15	65	1	63.3	9/GR19	
EQAG0001	-94.80	28	-90.36	-0.57	0.94	0.89	99	1	61.3	9/GR19	
GRD00003	-79.30	28	-61.62	12.34	0.80	0.80	90	2	58.9		
GTMIFRB2	-107.30	28	-90.50	15.64	1.03	0.80	84	1	61.4		
GUFMG02	-52.80	28	-56.42	8.47	4.16	0.81	123	2	63.0	2 7	
HWA00002	-165.80	28	-165.79	23.32	4.20	0.80	160	2	59.0	9/GR1	10
HWA00003	-174.80	28	-166.10	23.42	4.25	0.80	159	2	59.0	9/GR2	10
MEX01NTE	-77.80	28	-105.80	25.99	2.88	2.07	155	2	60.8	1	
MEX02NTE	-135.80	28	-107.36	26.32	3.80	1.57	149	2	61.5	1	10
MEX02SUR	-126.80	28	-96.39	19.88	3.19	1.87	158	2	62.8	1	10
PNRIFRB2	-121.00	28	-80.15	8.46	1.01	0.80	170	1	65.1		
PRU00004	-85.80	28	-74.19	-8.39	3.74	2.45	112	2	63.2		
PTRVIR01	-100.80	28	-65.85	18.12	0.80	0.80	90	2	60.9	1 6 9/GR20	
PTRVIR02	-109.80	28	-65.85	18.12	0.80	0.80	90	2	61.4	1 6 9/GR21	
USAEH001	-61.30	28	-85.16	36.21	5.63	3.32	22	2	62.1	1 5 6	
USAEH002	-100.80	28	-89.28	36.16	5.65	3.78	170	2	62.0	1 6 9/GR20	10
USAEH003	-109.80	28	-90.12	36.11	5.55	3.56	161	2	62.4	1 6 9/GR21	10
USAEH004	-118.80	28	-91.16	36.05	5.38	3.24	153	2	62.9	1 5 6	10
USAPSA02	-165.80	28	-117.79	40.58	4.04	0.82	135	2	63.6	9/GR1	
USAPSA03	-174.80	28	-118.20	40.15	3.63	0.80	136	2	65.3	9/GR2	
USAWH101	-147.80	28	-109.70	38.13	5.52	1.96	142	2	62.4	10	
USAWH102	-156.80	28	-111.40	38.57	5.51	1.55	138	2	63.5	10	
VEN02VEN	-103.80	28	-63.50	15.50	0.80	0.80	90	2	60.1	9/GR22	
VEN11VEN	-103.80	28	-66.79	6.90	2.50	1.77	122	2	65.6	9/GR22	10

## 12 632.24 MHz (29)

1	2	3	4		5		6	7	8	9	
ALS00002	-166.20	29	-149.66	58.37	3.76	1.24	170	1	59.9	9/GR1	10
ALS00003	-175.20	29	-150.98	58.53	3.77	1.11	167	1	60.2	9/GR2	10
ARGINSU4	-94.20	29	-52.98	-59.81	3.40	0.80	19	1	60.1	9/GR3	
ARGINSU5	-55.20	29	-44.17	-59.91	3.77	0.80	13	1	59.5	9/GR4	
ARGSUR04	-94.20	29	-65.04	-43.33	3.32	1.50	40	1	60.9	9/GR3	
ARGSUR05	-55.20	29	-63.68	-43.01	2.54	2.38	152	1	60.2	9/GR4	
B CE311	-64.20	29	-40.60	-6.07	3.04	2.06	174	1	61.9	8/9/GR7	
B CE312	-45.20	29	-40.27	-6.06	3.44	2.09	174	1	61.2	8/9/GR9	10 11
B CE411	-64.20	29	-50.97	-15.27	3.86	1.38	49	1	62.9	8/9/GR7	
B CE412	-45.20	29	-50.71	-15.30	3.57	1.56	52	1	63.0	8/9/GR9	10 12
B CE511	-64.20	29	-53.10	-2.90	2.44	2.13	104	1	63.4	8/9/GR7	
B NO611	-74.20	29	-59.60	-11.62	2.85	1.69	165	2	63.1	8/9/GR8	
B NO711	-74.20	29	-60.70	-1.78	3.54	1.78	126	2	63.1	8/9/GR8	
B NO811	-74.20	29	-68.76	-4.71	2.37	1.65	73	2	63.1	8/9/GR8	
B SU111	-81.20	29	-51.12	-25.63	2.76	1.05	50	1	63.2	8/9/GR6	
B SU112	-45.20	29	-50.75	-25.62	2.47	1.48	56	1	62.5	8/9/GR9	11
B SU211	-81.20	29	-44.51	-16.95	3.22	1.36	60	1	62.8	8/9/GR6	
B SU212	-45.20	29	-44.00	-16.87	3.20	1.96	58	1	61.6	8/9/GR9	12
BERBERMU	-96.20	29	-64.77	32.32	0.80	0.80	90	2	57.0		
BOLAND01	-115.20	29	-65.04	-16.76	2.49	1.27	76	1	68.0	9/GR5	
CAN01101	-138.20	29	-125.63	57.24	3.45	1.27	157	1	59.7	9/GR10	10
CAN01201	-138.20	29	-112.04	55.95	3.35	0.97	151	1	59.8	9/GR10	10
CAN01202	-72.70	29	-107.70	55.63	2.74	1.12	32	1	59.8		
CAN01203	-129.20	29	-111.48	55.61	3.08	1.15	151	1	59.7	9/GR12	10
CAN01303	-129.20	29	-102.42	57.12	3.54	0.91	154	1	60.2	9/GR12	10
CAN01304	-91.20	29	-99.12	57.36	1.98	1.72	2	1	60.0	9/GR13	
CAN01403	-129.20	29	-89.75	52.02	4.68	0.80	148	1	62.1	9/GR12	10
CAN01404	-91.20	29	-84.82	52.42	3.10	2.05	152	1	60.6	9/GR13	
CAN01405	-82.20	29	-84.00	52.39	2.84	2.29	172	1	60.5	9/GR14	
CAN01504	-91.20	29	-72.66	53.77	3.57	1.67	156	1	60.4	9/GR13	
CAN01505	-82.20	29	-71.77	53.79	3.30	1.89	162	1	60.3	9/GR14	
CAN01605	-82.20	29	-61.50	49.55	2.65	1.40	143	1	60.5	9/GR14	
CAN01606	-70.70	29	-61.30	49.55	2.40	1.65	148	1	60.4		
CHLCONT5	-106.20	29	-72.23	-35.57	2.60	0.80	55	1	59.6	9/GR17	
CHLPAC02	-106.20	29	-80.06	-30.06	1.36	0.80	69	1	59.4	9/GR17	
CLMAND01	-115.20	29	-74.72	5.93	3.85	1.63	114	1	65.3	9/GR5	10
CLM00001	-103.20	29	-74.50	5.87	3.98	1.96	118	1	63.9	10	
EQACAND1	-115.20	29	-78.40	-1.61	1.37	0.95	75	1	64.4	9/GR5	
EQAGAND1	-115.20	29	-90.34	-0.62	0.90	0.81	89	1	61.5	9/GR5	
HWA00002	-166.20	29	-165.79	23.42	4.20	0.80	160	1	59.0	9/GR1	10
HWA00003	-175.20	29	-166.10	23.42	4.25	0.80	159	1	58.9	9/GR2	10
JMC00002	-92.70	29	-77.30	18.12	0.80	0.80	90	2	60.1		
KNA00001	-79.70	29	-62.46	17.44	0.80	0.80	90	1	58.6		
MEX01NTE	-78.20	29	-105.81	26.01	2.89	2.08	155	1	60.7	1	
MEX01SUR	-69.20	29	-94.84	19.82	3.05	2.09	4	1	62.5	1	
MEX02NTE	-136.20	29	-107.21	26.31	3.84	1.55	148	1	61.4	1	10
MEX02SUR	-127.20	29	-96.39	19.88	3.18	1.87	157	1	62.8	1	10
PAQPAC01	-106.20	29	-109.18	-27.53	0.80	0.80	90	1	56.4	9/GR17	
PRG00002	-99.20	29	-58.66	-23.32	1.45	1.04	76	1	60.4		
PRUAND02	-115.20	29	-74.69	-8.39	3.41	1.79	95	1	64.3	9/GR5	
PTRVIR01	-101.20	29	-65.85	18.12	0.80	0.80	90	1	60.8	1 6 9/GR20	
PTRVIR02	-110.20	29	-65.86	18.12	0.80	0.80	90	1	61.3	1 6 9/GR21	
SPMFRAN3	-53.20	29	-67.24	47.51	3.16	0.80	7	1	60.6	2 7	
SURINAM2	-84.70	29	-55.69	4.35	1.00	0.80	86	1	63.5		
URG00001	-71.70	29	-56.22	-32.52	1.02	0.89	11	1	60.2		
USAEH001	-61.70	29	-85.19	36.21	5.63	3.33	22	1	62.1	1 5 6	
USAEH002	-101.20	29	-89.24	36.16	5.67	3.76	170	1	62.0	1 6 9/GR20	10
USAEH003	-110.20	29	-90.14	36.11	5.55	3.55	161	1	62.3	1 6 9/GR21	10
USAEH004	-119.20	29	-91.16	36.05	5.38	3.24	152	1	62.9	1 5 6	10
USAPSA02	-166.20	29	-117.80	40.58	4.03	0.82	135	1	63.5	9/GR1	
USAPSA03	-175.20	29	-118.27	40.12	3.62	0.80	136	1	65.3	9/GR2	
USAWH101	-148.20	29	-109.65	38.13	5.53	1.95	142	1	62.3	10	
USAWH102	-157.20	29	-111.41	38.57	5.51	1.54	138	1	63.5	10	
VENAND03	-115.20	29	-67.04	6.91	2.37	1.43	111	1	67.6	9/GR5	10

1	2	3	4	5	6	7	8	9			
ALS00002	-165.80	30	-149.63	58.52	3.81	1.23	171	2	59.9	9/GR1	10
ALS00003	-174.80	30	-150.95	58.54	3.77	1.11	167	2	60.2	9/GR2	10
ARGNORT4	-93.80	30	-63.96	-30.01	3.86	1.99	48	2	66.0		
ARGNORT5	-54.80	30	-62.85	-29.80	3.24	2.89	47	2	63.8		
ATNBEAM1	-52.80	30	-66.44	14.87	1.83	0.80	39	2	61.3		
B CE311	-63.80	30	-40.60	-6.07	3.04	2.06	174	2	61.9	8 9/GR7	
B CE312	-44.80	30	-40.26	-6.06	3.44	2.09	174	2	61.2	8 9/GR9	10 11
B CE411	-63.80	30	-50.97	-15.26	3.86	1.38	49	2	62.9	8 9/GR7	
B CE412	-44.80	30	-50.71	-15.30	3.57	1.56	52	2	63.0	8 9/GR9	10 12
B CE511	-63.80	30	-53.11	-2.98	2.42	2.15	107	2	63.4	8 9/GR7	
B NO611	-73.80	30	-59.60	-11.62	2.86	1.69	165	1	63.1	8 9/GR8	
B NO711	-73.80	30	-60.70	-1.78	3.54	1.78	126	1	63.1	8 9/GR8	
B NO811	-73.80	30	-68.75	-4.71	2.37	1.65	73	1	63.1	8 9/GR8	
B SE911	-101.80	30	-45.99	-19.09	2.22	0.80	62	2	65.7	8	
B SU111	-80.80	30	-51.10	-25.64	2.76	1.06	50	2	63.1	8 9/GR6	
B SU112	-44.80	30	-50.76	-25.62	2.47	1.48	56	2	62.6	8 9/GR9	11
B SU211	-80.80	30	-44.51	-16.94	3.22	1.37	60	2	62.8	8 9/GR6	
B SU212	-44.80	30	-43.99	-16.97	3.27	1.92	59	2	61.6	8 9/GR9	12
BLZ00001	-115.80	30	-88.68	17.27	0.80	0.80	90	2	59.2		
CAN01101	-137.80	30	-125.60	57.24	3.45	1.27	157	2	59.7	9/GR10	10
CAN01201	-137.80	30	-111.92	55.89	3.33	0.98	151	2	59.8	9/GR10	10
CAN01202	-72.30	30	-107.64	55.62	2.75	1.11	32	2	59.8		
CAN01203	-128.80	30	-111.43	55.56	3.07	1.15	151	2	59.7	9/GR12	10
CAN01303	-128.80	30	-102.39	57.12	3.54	0.92	154	2	60.3	9/GR12	10
CAN01304	-90.80	30	-99.00	57.33	1.96	1.73	1	2	60.0	9/GR13	
CAN01403	-128.80	30	-89.70	52.02	4.67	0.80	148	2	62.1	9/GR12	10
CAN01404	-90.80	30	-84.78	52.41	3.09	2.06	153	2	60.6	9/GR13	
CAN01405	-81.80	30	-84.02	52.34	2.82	2.30	172	2	60.5	9/GR14	
CAN01504	-90.80	30	-72.68	53.78	3.57	1.67	157	2	60.4	9/GR13	
CAN01505	-81.80	30	-71.76	53.76	3.30	1.89	162	2	60.3	9/GR14	
CAN01605	-81.80	30	-61.54	49.50	2.66	1.39	144	2	60.5	9/GR14	
CAN01606	-70.30	30	-61.32	49.51	2.41	1.65	148	2	60.4		
CHLCONT4	-105.80	30	-69.59	-23.20	2.21	0.80	68	2	59.3	9/GR16	
CHLCONT6	-105.80	30	-73.52	-55.52	3.65	1.31	39	2	59.7	9/GR16	
CRBBAH01	-92.30	30	-76.09	24.13	1.83	0.80	141	1	61.9	9/GR18	
CRBBER01	-92.30	30	-64.76	32.13	0.80	0.80	90	1	56.9	9/GR18	
CRBBLZ01	-92.30	30	-88.61	17.26	0.80	0.80	90	1	58.9	9/GR18	
CRBEC001	-92.30	30	-60.07	8.26	4.20	0.86	115	1	64.6	9/GR18	
CRBJMC01	-92.30	30	-79.45	17.97	0.99	0.80	151	1	61.3	9/GR18	
CTR00201	-130.80	30	-84.33	9.67	0.82	0.80	119	2	66.0		
DMAIFRB1	-79.30	30	-61.30	15.35	0.80	0.80	90	2	58.7		
EQAC0001	-94.80	30	-78.31	-1.52	1.48	1.15	65	1	63.3	9/GR19	
EQAG0001	-94.80	30	-90.36	-0.57	0.94	0.89	99	1	61.2	9/GR19	
HWAA0002	-165.80	30	-165.79	23.32	4.20	0.80	160	2	59.0	9/GR1	10
HWAA0003	-174.80	30	-166.10	23.42	4.25	0.80	159	2	59.0	9/GR2	10
MEX01NTE	-77.80	30	-105.80	25.99	2.88	2.07	155	2	60.7	1	
MEX02NTE	-135.80	30	-107.36	26.32	3.80	1.57	149	2	61.4	1	10
MEX02SUR	-126.80	30	-96.39	19.88	3.19	1.87	158	2	62.8	1	10
NCG00003	-107.30	30	-84.99	12.90	1.05	1.01	176	1	63.6		
PRU00004	-85.80	30	-74.19	-8.39	3.74	2.45	112	2	63.1		
PTRVIR01	-100.80	30	-65.85	18.12	0.80	0.80	90	2	60.8	1 6 9/GR20	
PTRVIR02	-109.80	30	-65.85	18.12	0.80	0.80	90	2	61.4	1 6 9/GR21	
USAEH001	-61.30	30	-85.16	36.21	5.63	3.32	22	2	62.1	1 5 6	
USAEH002	-100.80	30	-89.28	36.16	5.65	3.78	170	2	62.0	1 6 9/GR20	10
USAEH003	-109.80	30	-90.12	36.11	5.55	3.56	161	2	62.3	1 6 9/GR21	10
USAEH004	-118.80	30	-91.16	36.05	5.38	3.24	153	2	62.9	1 5 6	10
USAPSA02	-165.80	30	-117.79	40.58	4.04	0.82	135	2	63.5	9/GR1	
USAPSA03	-174.80	30	-118.20	40.15	3.63	0.80	136	2	65.3	9/GR2	
USAWH101	-147.80	30	-109.70	38.13	5.52	1.96	142	2	62.3	10	
USAWH102	-156.80	30	-111.40	38.57	5.51	1.55	138	2	63.5	10	
VEN11VEN	-103.80	30	-66.79	6.90	2.50	1.77	122	2	65.5	10	

## 12 661.40 MHz (31)

1	2	3	4	5	6	7	8	9			
ALS00002	-166.20	31	-149.66	58.37	3.76	1.24	170	1	60.0	9/GR1	10
ALS00003	-175.20	31	-150.98	58.53	3.77	1.11	167	1	60.2	9/GR2	10
ARGINSU4	-94.20	31	-52.98	-59.81	3.40	0.80	19	1	60.1	9/GR3	
ARGINSU5	-55.20	31	-44.17	-59.91	3.77	0.80	13	1	59.5	9/GR4	
ARGSUR04	-94.20	31	-65.04	-43.33	3.32	1.50	40	1	60.9	9/GR3	
ARGSUR05	-55.20	31	-63.68	-43.01	2.54	2.38	152	1	60.3	9/GR4	
B CE311	-64.20	31	-40.60	-6.07	3.04	2.06	174	1	61.9	8 9/GR7	
B CE312	-45.20	31	-40.27	-6.06	3.44	2.09	174	1	61.3	8 9/GR9	10 11
B CE411	-64.20	31	-50.97	-15.27	3.86	1.38	49	1	62.9	8 9/GR7	
B CE412	-45.20	31	-50.71	-15.30	3.57	1.56	52	1	63.1	8 9/GR9	10 12
B CE511	-64.20	31	-53.10	-2.90	2.44	2.13	104	1	63.4	8 9/GR7	
B NO611	-74.20	31	-59.60	-11.62	2.85	1.69	165	2	63.2	8 9/GR8	
B NO711	-74.20	31	-60.70	-1.78	3.54	1.78	126	2	63.2	8 9/GR8	
B NO811	-74.20	31	-68.76	-4.71	2.37	1.65	73	2	63.1	8 9/GR8	
B SU111	-81.20	31	-51.12	-25.63	2.76	1.05	50	1	63.2	8 9/GR6	
B SU112	-45.20	31	-50.75	-25.62	2.47	1.48	56	1	62.6	8 9/GR9	11
B SU211	-81.20	31	-44.51	-16.95	3.22	1.36	60	1	62.8	8 9/GR6	
B SU212	-45.20	31	-44.00	-16.87	3.20	1.96	58	1	61.6	8 9/GR9	12
BERBERMU	-96.20	31	-64.77	32.32	0.80	0.80	90	2	57.0		
BOLAND01	-115.20	31	-65.04	-16.76	2.49	1.27	76	1	68.1	9/GR5	
BOL00001	-87.20	31	-64.61	-16.71	2.52	2.19	85	1	64.2		
BRB00001	-92.70	31	-59.85	12.93	0.80	0.80	90	2	59.4		
CAN01101	-138.20	31	-125.63	57.24	3.45	1.27	157	1	59.7	9/GR10	10
CAN01201	-138.20	31	-112.04	55.95	3.35	0.97	151	1	59.8	9/GR10	10
CAN01202	-72.70	31	-107.70	55.63	2.74	1.12	32	1	59.8		
CAN01203	-129.20	31	-111.48	55.61	3.08	1.15	151	1	59.7	9/GR12	10
CAN01303	-129.20	31	-102.42	57.12	3.54	0.91	154	1	60.3	9/GR12	10
CAN01304	-91.20	31	-99.12	57.36	1.98	1.72	2	1	60.1	9/GR13	
CAN01403	-129.20	31	-89.75	52.02	4.68	0.80	148	1	62.1	9/GR12	10
CAN01404	-91.20	31	-84.82	52.42	3.10	2.05	152	1	60.6	9/GR13	
CAN01405	-82.20	31	-84.00	52.39	2.84	2.29	172	1	60.5	9/GR14	
CAN01504	-91.20	31	-72.66	53.77	3.57	1.67	156	1	60.4	9/GR13	
CAN01505	-82.20	31	-71.77	53.79	3.30	1.89	162	1	60.4	9/GR14	
CAN01605	-82.20	31	-61.50	49.55	2.65	1.40	143	1	60.5	9/GR14	
CAN01606	-70.70	31	-61.30	49.55	2.40	1.65	148	1	60.5		
CHLCONT5	-106.20	31	-72.23	-35.57	2.60	0.80	55	1	59.6	9/GR17	
CHLPAC02	-106.20	31	-80.06	-30.06	1.36	0.80	69	1	59.4	9/GR17	
CLMAND01	-115.20	31	-74.72	5.93	3.85	1.63	114	1	65.4	9/GR5	10
CLM00001	-103.20	31	-74.50	5.87	3.98	1.96	118	1	63.9	10	
CUB00001	-89.20	31	-79.81	21.62	2.24	0.80	168	1	61.3		
EQACAND1	-115.20	31	-78.40	-1.61	1.37	0.95	75	1	64.4	9/GR5	
EQAGAND1	-115.20	31	-90.34	-0.62	0.90	0.81	89	1	61.6	9/GR5	
GRD00059	-57.20	31	-61.58	12.29	0.80	0.80	90	1	58.7		
GRLDNK01	-53.20	31	-44.89	66.56	2.70	0.82	173	1	60.2	2	
GUY00201	-84.70	31	-59.19	4.78	1.44	0.85	95	1	63.8		
HWA00002	-166.20	31	-165.79	23.42	4.20	0.80	160	1	59.0	9/GR1	10
HWA00003	-175.20	31	-166.10	23.42	4.25	0.80	159	1	59.0	9/GR2	10
MEX01INTE	-78.20	31	-105.81	26.01	2.89	2.08	155	1	60.8	1	
MEX01SUR	-69.20	31	-94.84	19.82	3.05	2.09	4	1	62.5	1	
MEX02NTE	-136.20	31	-107.21	26.31	3.84	1.55	148	1	61.5	1	10
MEX02SUR	-127.20	31	-96.39	19.88	3.18	1.87	157	1	62.8	1	10
MSR00001	-79.70	31	-61.73	16.75	0.80	0.80	90	1	58.9	4	
PAQPAC01	-106.20	31	-109.18	-27.53	0.80	0.80	90	1	56.4	9/GR17	
PRG00002	-99.20	31	-58.66	-23.32	1.45	1.04	76	1	60.5		
PRUAND02	-115.20	31	-74.69	-8.39	3.41	1.79	95	1	64.3	9/GR5	
PTRVIR01	-101.20	31	-65.85	18.12	0.80	0.80	90	1	60.8	1 6 9/GR20	
PTRVIR02	-110.20	31	-65.86	18.12	0.80	0.80	90	1	61.3	1 6 9/GR21	
URG00001	-71.70	31	-56.22	-32.52	1.02	0.89	11	1	60.2		
USAEH001	-61.70	31	-85.19	36.21	5.63	3.33	22	1	62.1	1 5 6	
USAEH002	-101.20	31	-89.24	36.16	5.67	3.76	170	1	62.0	1 6 9/GR20	10
USAEH003	-110.20	31	-90.14	36.11	5.55	3.55	161	1	62.4	1 6 9/GR21	10
USAEH004	-119.20	31	-91.16	36.05	5.38	3.24	152	1	62.9	1 5 6	10
USAPSA02	-166.20	31	-117.80	40.58	4.03	0.82	135	1	63.6	9/GR1	
USAPSA03	-175.20	31	-118.27	40.12	3.62	0.80	136	1	65.4	9/GR2	
USAWH101	-148.20	31	-109.65	38.13	5.53	1.95	142	1	62.4	10	
USAWH102	-157.20	31	-111.41	38.57	5.51	1.54	138	1	63.5	10	
VENAND03	-115.20	31	-67.04	6.91	2.37	1.43	111	1	67.7	9/GR5	10

1	2	3	4	5	6	7	8	9			
ALS00002	-165.80	32	-149.63	58.52	3.81	1.23	171	2	59.9	9/GR1	10
ALS00003	-174.80	32	-150.95	58.54	3.77	1.11	167	2	60.2	9/GR2	10
ARGNORT4	-93.80	32	-63.96	-30.01	3.86	1.99	48	2	66.1		
ARGNORT5	-54.80	32	-62.85	-29.80	3.24	2.89	47	2	63.9		
B CE311	-63.80	32	-40.60	-6.07	3.04	2.06	174	2	61.9	8 9/GR7	
B CE312	-44.80	32	-40.26	-6.06	3.44	2.09	174	2	61.3	8 9/GR9	10 11
B CE411	-63.80	32	-50.97	-15.26	3.86	1.38	49	2	62.9	8 9/GR7	
B CE412	-44.80	32	-50.71	-15.30	3.57	1.56	52	2	63.1	8 9/GR9	10 12
B CE511	-63.80	32	-53.11	-2.98	2.42	2.15	107	2	63.4	8 9/GR7	
B NO611	-73.80	32	-59.60	-11.62	2.86	1.69	165	1	63.2	8 9/GR8	
B NO711	-73.80	32	-60.70	-1.78	3.54	1.78	126	1	63.2	8 9/GR8	
B NO811	-73.80	32	-68.75	-4.71	2.37	1.65	73	1	63.2	8 9/GR8	
B SE911	-101.80	32	-45.99	-19.09	2.22	0.80	62	2	65.7	8	
B SU111	-80.80	32	-51.10	-25.64	2.76	1.06	50	2	63.2	8 9/GR6	
B SU112	-44.80	32	-50.76	-25.62	2.47	1.48	56	2	62.6	8 9/GR9	11
B SU211	-80.80	32	-44.51	-16.94	3.22	1.37	60	2	62.8	8 9/GR6	
B SU212	-44.80	32	-43.99	-16.97	3.27	1.92	59	2	61.6	8 9/GR9	12
CAN01101	-137.80	32	-125.60	57.24	3.45	1.27	157	2	59.7	9/GR10	10
CAN01201	-137.80	32	-111.92	55.89	3.33	0.98	151	2	59.8	9/GR10	10
CAN01202	-72.30	32	-107.64	55.62	2.75	1.11	32	2	59.7		
CAN01203	-128.80	32	-111.43	55.56	3.07	1.15	151	2	59.8	9/GR12	10
CAN01303	-128.80	32	-102.39	57.12	3.54	0.92	154	2	60.3	9/GR12	10
CAN01304	-90.80	32	-99.00	57.33	1.96	1.73	1	2	60.0	9/GR13	
CAN01403	-128.80	32	-89.70	52.02	4.67	0.80	148	2	62.1	9/GR12	10
CAN01404	-90.80	32	-84.78	52.41	3.09	2.06	153	2	60.6	9/GR13	
CAN01405	-81.80	32	-84.02	52.34	2.82	2.30	172	2	60.5	9/GR14	
CAN01504	-90.80	32	-72.68	53.78	3.57	1.67	157	2	60.4	9/GR13	
CAN01505	-81.80	32	-71.76	53.76	3.30	1.89	162	2	60.4	9/GR14	
CAN01605	-81.80	32	-61.54	49.50	2.66	1.39	144	2	60.5	9/GR14	
CAN01606	-70.30	32	-61.32	49.51	2.41	1.65	148	2	60.5		
CHLCONT4	-105.80	32	-69.59	-23.20	2.21	0.80	68	2	59.3	9/GR16	
CHLCONT6	-105.80	32	-73.52	-55.52	3.65	1.31	39	2	59.8	9/GR16	
CRBBAH01	-92.30	32	-76.09	24.13	1.83	0.80	141	1	62.0	9/GR18	
CRBBER01	-92.30	32	-64.76	32.13	0.80	0.80	90	1	57.0	9/GR18	
CRBBLZ01	-92.30	32	-88.61	17.26	0.80	0.80	90	1	58.9	9/GR18	
CRBEC001	-92.30	32	-60.07	8.26	4.20	0.86	115	1	64.6	9/GR18	
CRBJMC01	-92.30	32	-79.45	17.97	0.99	0.80	151	1	61.4	9/GR18	
EQAC0001	-94.80	32	-78.31	-1.52	1.48	1.15	65	1	63.3	9/GR19	
EQAG0001	-94.80	32	-90.36	-0.57	0.94	0.89	99	1	61.3	9/GR19	
GRD00003	-79.30	32	-61.62	12.34	0.80	0.80	90	2	58.9		
GTMIFRB2	-107.30	32	-90.50	15.64	1.03	0.80	84	1	61.4		
GUFMGG02	-52.80	32	-56.42	8.47	4.16	0.81	123	2	63.0	2 7	
HWA00002	-165.80	32	-165.79	23.32	4.20	0.80	160	2	59.0	9/GR1	10
HWA00003	-174.80	32	-166.10	23.42	4.25	0.80	159	2	59.0	9/GR2	10
MEX01NTE	-77.80	32	-105.80	25.99	2.88	2.07	155	2	60.8	1	
MEX02NTE	-135.80	32	-107.36	26.32	3.80	1.57	149	2	61.5	1	10
MEX02SUR	-126.80	32	-96.39	19.88	3.19	1.87	158	2	62.8	1	10
PNRIFRB2	-121.00	32	-80.15	8.46	1.01	0.80	170	1	65.1		
PRU00004	-85.80	32	-74.19	-8.39	3.74	2.45	112	2	63.2		
PTRVIR01	-100.80	32	-65.85	18.12	0.80	0.80	90	2	60.9	1 6 9/GR20	
PTRVIR02	-109.80	32	-65.85	18.12	0.80	0.80	90	2	61.4	1 6 9/GR21	
USAEH001	-61.30	32	-85.16	36.21	5.63	3.32	22	2	62.1	1 5 6	
USAEH002	-100.80	32	-89.28	36.16	5.65	3.78	170	2	62.0	1 6 9/GR20	10
USAEH003	-109.80	32	-90.12	36.11	5.55	3.56	161	2	62.4	1 6 9/GR21	10
USAEH004	-118.80	32	-91.16	36.05	5.38	3.24	153	2	62.9	1 5 6	10
USAPSA02	-165.80	32	-117.79	40.58	4.04	0.82	135	2	63.6	9/GR1	
USAPSA03	-174.80	32	-118.20	40.15	3.63	0.80	136	2	65.3	9/GR2	
USAWH101	-147.80	32	-109.70	38.13	5.52	1.96	142	2	62.4	10	
USAWH102	-156.80	32	-111.40	38.57	5.51	1.55	138	2	63.5	10	
VEN02VEN	-103.80	32	-63.50	15.50	0.80	0.80	90	2	60.1	9/GR22	
VEN11VEN	-103.80	32	-66.79	6.90	2.50	1.77	122	2	65.6	9/GR22	10

## ARTICLE 11 (REV.WRC-19)

**Plan for the broadcasting-satellite service in the frequency bands  
11.7-12.2 GHz in Region 3 and 11.7-12.5 GHz in Region 1**

## 11.1 COLUMN HEADINGS OF THE PLAN

- Col. 1 *Notifying administration symbol.*
- Col. 2 *Beam identification* (Column 2, normally, contains the symbol designating the administration or the geographical area taken from Table B1 of the Preface to the International Frequency Information Circular (BR IFIC), followed by the symbol designating the service area).
- Col. 3 *Nominal orbital position*, in degrees and hundredths of a degree from the Greenwich meridian (negative values indicate longitudes which are west of the Greenwich meridian; positive values indicate longitudes which are east of the Greenwich meridian).
- Col. 4 *Nominal intersection of the beam axis with the Earth* (boresight or aim point in the case of a non-elliptical beam), longitude and latitude, in degrees and hundredths of a degree.
- Col. 5 *Space station transmitting antenna characteristics* (elliptical beams). This column contains three numerical values corresponding to the major axis, the minor axis and the major axis orientation respectively of the elliptical cross-section half-power beamwidth, in degrees and hundredths of a degree. Orientation of the ellipse is determined as follows: in a plane normal to the beam axis, the direction of a major axis of the ellipse is specified as the angle measured anticlockwise from a line parallel to the equatorial plane to the major axis of the ellipse, to the nearest degree.
- Col. 6 *Space station transmitting antenna pattern code.*

The codes used for the antenna pattern of the transmitting space station (downlink) antenna are defined as follows:

MOD13FRTSS	Figure 13 in Annex 5 (Recommendation ITU-R BO.1445)
R13TSS	Figure 9 and § 3.13.3 in Annex 5
R123FR	Figure 11 and § 3.13.3 in Annex 5

In cases where the “Space station transmitting antenna pattern code” field is blank, the necessary antenna pattern data are provided by shaped beam data submitted by the administration. These data are stored in Column 7. A particular shaped beam is identified by the combination of Column 1, Column 7 and Column 13. In such cases the maximum cross-polar gain is given under Column 8 in the “Cross-polar gain” field.



In cases where the “Space station transmitting antenna pattern code” field contains a code which starts with “CB\_” characters, it is a composite beam. Any composite beam consists of two or more elliptical beams. Each composite beam is described in the special composite beam file as having the same name plus a GXT extension (e.g. the description of the CB\_COMP\_BM1 composite beam is stored in the CB\_COMP\_BM1.GXT file).

- Col. 7 *Space station transmitting antenna shaped (non-elliptical and non-composite) beam identification.*
- Col. 8 *Maximum space station transmitting antenna co-polar and cross-polar (in the case of shaped beam) isotropic gain (dBi).*
- Col. 9 *Earth station receiving antenna pattern code and maximum antenna co-polar gain (dBi).*

The codes used for receiving earth station (downlink) antenna patterns are defined as follows:

R13RES	Figure 7 and § 3.7.2 in Annex 5
MODRES	Figure 7bis and § 3.7.2 in Annex 5 (Recommendation ITU-R BO.1213)

- Col. 10 *Polarization (CL – circular left, CR – circular right, LE – linear referenced to the equatorial plane) and polarization angle in degrees and hundredths of a degree (in the case of linear polarization only).*
- Col. 11 *e.i.r.p.* in the direction of maximum radiation (dBW).
- Col. 12 *Designation of emission.*
- Col. 13 *Identity of the space station.*
- Col. 14 *Group code* (an identification code which indicates that all assignments with the same group identification code will be treated as a group).

Group code: if an assignment is part of the group:

- a) The equivalent protection margin to be used for the application of Article 4 shall be calculated on the following basis:
  - for the calculation of interference to assignments that are part of a group, only the interference contributions from assignments that are not part of the same group are to be included; and
  - for the calculation of interference from assignments belonging to a group to assignments that are not part of that same group, only the worst interference contribution from that group shall be used on a test point to test point basis.

- b) If an administration notifies the same frequency in more than one beam of a group for use at the same time, the aggregate carrier-to-interference ratio (*C/I*) produced by all emissions from that group shall not exceed the *C/I* ratio calculated on the basis of § a) above.

Col. 15 *Assignment status.*

The assignment status codes used for beams are defined as follows:

P	Assignment in the Plan which has not been brought into use and/or the date of bringing into use has not been confirmed to the Bureau. For this category of assignments, WRC-2000 protection ratios are applied (21 dB co-channel and 16 dB adjacent channel).
PE	Assignment in the Plan which is in conformity with Appendix 30, has been notified, brought into use and the date of bringing into use has been confirmed to the Bureau before 12 May 2000. For this category of assignments, WRC-97 protection ratios are applied (24 dB co-channel and 16 dB adjacent channel).

Col. 16 *Remarks.*

11.2 TEXT FOR NOTES IN THE REMARKS COLUMN  
OF THE PLAN (REV.WRC-15)

- 1 To be dedicated to the Islamic programme envisaged in WARC SAT-77 documents.
- 2 Not used.
- 3 Provisional beam. These assignments have been included in the Plan by WRC-97. These assignments are for exclusive use by Palestine, subject to the Israeli-Palestinian Interim Agreement of 28 September 1995, Resolution 741 of the Council notwithstanding and Resolution 99 (Minneapolis, 1998) of the Plenipotentiary Conference.
- 4 Assignment intended to ensure coverage of Algeria, Libya, Morocco, Mauritania and Tunisia, with the agreement of the countries concerned. If required, it may be used with the characteristics of the beam TUN15000.
- 5 This assignment shall be brought into use only when the limits referred to in Table 1 are not exceeded or with the agreement of the administrations identified in Table 2, whose networks/beams listed in this Table may be affected, with respect to (see also the Note to § 11.2):
- a) assignments in the Region 2 Plan on 12 May 2000; *or*
- b) assignments in the terrestrial services which are recorded in the Master Register with a favourable finding or received by the Bureau prior to 12 May 2000 for recording in the Master Register and which subsequently receive a favourable finding based on the Plan as it existed on 12 May 2000; *or*

- c) assignments in the fixed-satellite service which:
- are recorded in the Master Register prior to 12 May 2000 with a favourable finding; *or*
  - have been coordinated under the provisions of No. **9.7** (or No. **1060**) or § 7.2.1 of Article 7 prior to 12 May 2000; *or*
  - are in process of coordination under the provisions of No. **9.7** (or No. **1060**) or § 7.2.1 of Article 7 prior to 31 July 2000 for which complete Appendix 4 data (or Appendix 3 data, as appropriate) have been received by the Bureau under the relevant provisions of Article 9 (or Article 11, as appropriate):
    - filings received by the Bureau prior to 12 May 2000 at 1700 h (Istanbul time) shall be taken into account in the pertinent compatibility analysis by applying the pfd criteria referred to in Table 1; *or*
    - filings received by the Bureau after 12 May 2000 at 1700 h (Istanbul time), but before 31 July 2000, shall be taken into account by applying the sharing criteria of  $-138 \text{ dB(W/(m}^2 \cdot 27 \text{ MHz))}$  or the pfd criteria referred to in Table 1, whichever is higher.

6 This assignment shall not claim protection from interference caused by the assignments which pertain to networks/beams identified in Table 3 which are in conformity with the Region 2 Plan on 12 May 2000 (see also the Note to § 11.2).

7 This assignment shall not claim protection from interference caused by assignments in the fixed-satellite service which pertain to networks/beams identified in Table 3 (see also the Note to § 11.2) and:

- a) either are recorded in the Master Register with a favourable finding prior to 12 May 2000;
- b) or for which complete Appendix 4 data (or Appendix 3 data, as appropriate) under the relevant provisions of Article 9 (or No. **1060**, or § 7.2.1 of Article 7, as appropriate) have been received prior to 12 May 2000, which have been brought into use prior to 12 May 2000 and for which the complete due diligence information, in accordance with Annex 2 to Resolution **49 (Rev.WRC-15)**, has been received prior to 12 May 2000. (WRC-15)

8 This assignment shall not claim protection from the assignments of the administrations for terrestrial services identified in Table 4 which are recorded in the Master Register with a favourable finding, or received by the Bureau prior to 12 May 2000 for recording in the Master Register and which subsequently receive a favourable finding based on the Plan as it existed on 12 May 2000 (see also the Note to § 11.2).

TABLE 1

Symbol	Criteria
a	§ 3 of Annex 1 <sup>1</sup>
b	§ 4 of Annex 1 <sup>1</sup>
c	§ 6 of Annex 1 <sup>1</sup>

<sup>1</sup> These paragraphs and this Annex are contained in this Appendix as adopted by WRC-03.

NOTE – In cases where assignments from the WRC-97 Plan without remarks were included in the WRC-2000 Regions 1 and 3 Plan without change, or with conversion of modulation from analogue to digital, or a change from normal roll-off to fast roll-off antenna characteristics, the coordination status afforded by the WRC-97 Plan shall be preserved.

In cases where assignments from the WRC-97 Plan with remarks were included in the WRC-2000 Regions 1 and 3 Plan without change, or with conversion of modulation from analogue to digital, or a change from normal roll-off to fast roll-off antenna pattern, the compatibility will be reassessed using the revised criteria and methodology of WRC-2000 and the remarks of the WRC-97 Plan assignment will either be maintained or reduced on the basis of the results of this analysis.

In other cases the methodology described in Notes 5 to 8 shall be applied.

TABLE 2 (WRC-19)  
**Affected administrations and corresponding networks/beams identified based on Note 5 in § 11.2 of Article 11**

Beam name	Channels	Ref. Table 1	Affected administrations*	Affected networks/beams*
AR34000	40	c	CHN, G, J, KOR, MILA, THA, UAE, USA	AM-SAT-A4, ASIASAT-AKX, ASIASAT-CKX, ASIASAT-EKX, EMARSAT-1G, JCSAT-3A, JCSAT-3B, KOREASAT-1, MEASAT-1, MEASAT-91.5E, N-SAT-110E, N-SAT-128, SIC-1, THAICOM-A2B, THAICOM-GIK
BEL01800	26, 28, 30, 32, 34, 36, 38, 40	c	PAK	PAKSAT-1
BFA10700	22, 24	c	E	HISPASAT-1, HISPASAT-2C3 KU
CVF08300	1, 3, 5, 7, 9, 11	c	USA	INTELSAT 359E, INTELSAT 359E, INTELSAT 0 359E
CYP08600	1, 3, 5, 7, 9, 11, 13	c	USA	INTELSAT 359E, INTELSAT 8 359E
FSM00000	1, 3, 5, 7, 9, 11, 13	c	USA	INTELSAT 157E
GMB30200	1, 5, 9, 13, 17	c	USA	USASAT-26A
GNB30400	22, 24	c	E	HISPASAT-1, HISPASAT-2C3 KU
GRC10500	2, 4, 6, 8, 10, 12	c	USA	INTELSAT 359E, INTELSAT 8 359E, INTELSAT 0 359E
GH119200	2, 4, 6, 8, 10, 12, 14, 16, 18, 20	c	USA	USASAT-26A
IRL21100	1, 3, 5, 7, 9, 11, 13, 15, 17, 19	c	USA	USASAT-26A
ISL04900	27	a	GUY	GUY00302
ISL04900	29, 39	a	JMC	JMC00005
ISL04900	31, 33, 35, 37	a	GUY, JMC	GUY00302, JMC00005
ISL04900	23	c	B, USA	B-SAT 1, USASAT-14L
KIR 100	1, 3, 5, 7, 9, 11, 13	c	USA	INTELSAT 177E, USASAT-14K
KIR 100	17	c	USA	USASAT-14K
MJI 100	1, 3, 5, 7, 9, 11, 13	c	USA	INTELSAT 342E, INTELSAT 8 342E, INTELSAT 8 340E
MNG24800	31, 35	c	CHN, THA	APSTAR-4, THAICOM-A2B, THAICOM-GIK
MOZ30700	2, 6, 10	c	USA	INTELSAT 359E, INTELSAT 8 359E, INTELSAT 0 359E
NGR11500	2, 4, 6, 8, 10, 12, 14, 16, 18, 20	c	USA	USASAT-26A
NOR12000	1, 3, 5, 7, 9, 11, 13	c	USA	INTELSAT 359E, INTELSAT 8 359E, INTELSAT 0 359E
POR 100	1, 3, 5, 7, 9, 11, 13, 15, 17, 19	c	USA	USASAT-26A
RUS-4	28, 29, 33, 37	c	KOR	KOREASAT-1, KOREASAT-2
RUS-4	31, 35, 39	c	G	AM-SAT A4
SEN22200	23	c	USA	USASAT-26A
SOM31200	26, 28, 30, 32, 34, 36, 38, 40	c	PAK	PAKSAT-1
TGO22600	1, 3, 5, 7, 9, 11	c	USA	INTELSAT 8 330.5E
TGO22600	13	c	E, USA	HISPASAT-1, HISPASAT-2C3 KU, INTELSAT 8 330.5E
TGO22600	15, 17, 19	c	E	HISPASAT-1, HISPASAT-2C3 KU
TKO06900	26, 28, 30, 32, 34, 36, 38, 40	c	PAK	PAKSAT-1
TKM06800	26, 28, 30, 32, 34, 36, 38, 40	c	UAE	EMARSAT-HG
TON21500	2, 6, 10, 14, 18	c	USA	USASAT-14K
ZWE13500	1, 3, 5, 7, 9, 11, 13	c	USA	INTELSAT 359E, INTELSAT 8 359E

\* Administrations and corresponding networks/beams whose assignment(s) may receive interference from the beam shown in the left-hand column.

TABLE 3 (WRC-15)  
Affecting administrations and corresponding networks/beams identified based on Notes 6 and 7 in § 11.2 of Article 11

Beam name	Channels	Note	Affecting administrations*	Affecting networks/beams*
AND34100	2,-6,-10,12,14,16,18,20	7	USA	USASAT-26A
BFA10700	22,24	7	E	HISPASAT-1, HISPASAT-2C3 KU
CVA008300	1,3,5,7,9,11	7	USA	INTELSAT17 359E
CYP08600	1,3,5,7,9,11,13	7	USA	INTELSAT17 359E
DNK090XR	29	6	JMC	JMC00005
DNK090XR	33	6	GUY,JMC	GUY00302,JMC00005
DNK091XR	31,35	6	GUY,JMC	GUY00302,JMC00005
FJI19300	1,3,5,7,9,11,13	7	HOL	INTELSAT17 188E
GMB30200	1,3,5,7,9,11,13,15,17,19	7	USA	USASAT-26A
GNB30400	22,24	7	E	HISPASAT-1, HISPASAT-2C3 KU
GRC10500	2,-4,-6,-8,-10,12	7	USA	INTELSAT17 359E
GUT19200	2,-4,-6,-8,-10,12,14,16,18,20	7	USA	USASAT-26A
IRL21100	1,3,5,7,9,11,13,15,17,19	7	USA	USASAT-26A
ISL04900	27	6	GUY	GUY00302
ISL04900	29,39	6	JMC	JMC00005
ISL04900	31,33,35,37	6	GUY,JMC	GUY00302,JMC00005
KIR_100	1,3,5,7,9,11,13	7	USA	INTELSAT17 177E
MNG24800	27	7	J	SUPERBIRD-C
MNG24800	29,31,33,35,37,39	7	J,THA	THAICOM-A2B, SUPERBIRD-C
MOZ30700	2,-6,-10,12	7	USA	INTELSAT17 359E
MTN_100	22,24,26	7	USA	USASAT-26A
NGR11500	2,-4,-6,-8,-10,12,14,16,18,20	7	USA	USASAT-26A
NOR12000	1,3,5,7,9,11,13	7	USA	INTELSAT17 359E
POR_100	1,3,5,7,9,11,13,15,17,19	7	USA	USASAT-26A
RUS-4	25	7	J	JCSAT-IR, SUPERBIRD-C
RUS-4	28,29	7	J,KOR	SUPERBIRD-C, KOREASAT-1, KOREASAT-2
RUS-4	31,33,35,37,39	7	J,KOR	SUPERBIRD-C, KOREASAT-1, KOREASAT-2
SEN22200	23,25	7	USA	USASAT-26A
SMO05700	1,3,5,7,9,11,13	7	HOL	INTELSAT17 188E
SMR31100	1,3,5,7,9,11,13,15,17,19	7	USA	USASAT-26A
SRL25900	27	6	GUY	GUY00302
SRL25900	29,39	6	JMC	JMC00005
SRL25900	31,33,35,37	6	GUY,JMC	GUY00302,JMC00005
TGO22600	13,17	7	E	HISPASAT-1, HISPASAT-2C3 KU
TGO22600	15,17,19	7	E	HISPASAT-1, HISPASAT-2C3 KU
ZWE13500	1,3,5,7,9,11,13	7	USA	INTELSAT17 359E

\* Administrations and corresponding networks/beams whose assignment(s) may cause interference to the beam shown in the left-hand column.

TABLE 4 (WRC-07)  
**Affecting administrations and corresponding terrestrial stations identified based on Note 8 in § 11.2 of Article 11**

Beam name	Channels	Affecting administrations*	Affecting terrestrial stations*
EGY02600	2	ISR	HERZLIYA
F 09300	24, 26	SUI	GENEVE STUDIO C VOGT
I 08200	38, 40	AUT	EHRWALD
JOR22400	2	ISR	HERZLIYA, JERUSALEM
RUS-4	25, 26, 27, 28, 29, 31, 33, 35, 37, 39	J <sup>1</sup>	

\* Administrations and corresponding terrestrial stations whose assignment(s) may cause interference to the beam shown in the left-hand column.

1 The identification of this administration is based on its typical terrestrial station assignments as recorded in the Master Register.

TABLE 5  
**Table showing correspondence between channel numbers and assigned frequencies**

Channel No.	Assigned frequency (MHz)	Channel No.	Assigned frequency (MHz)
1	11 727.48	21	12 111.08
2	11 746.66	22	12 130.26
3	11 765.84	23	12 149.44
4	11 785.02	24	12 168.62
5	11 804.20	25	12 187.80
6	11 823.38	26	12 206.98
7	11 842.56	27	12 226.16
8	11 861.74	28	12 245.34
9	11 880.92	29	12 264.52
10	11 900.10	30	12 283.70
11	11 919.28	31	12 302.88
12	11 938.46	32	12 322.06
13	11 957.64	33	12 341.24
14	11 976.82	34	12 360.42
15	11 996.00	35	12 379.60
16	12 015.18	36	12 398.78
17	12 034.36	37	12 417.96
18	12 053.54	38	12 437.14
19	12 072.72	39	12 456.32
20	12 091.90	40	12 475.50

Note – Assigned frequency = 11 708.30 + 19.18  $n$ , where  $n$  is the channel number.



TABLE 6A (WRC-19)  
**Basic characteristics of the Regions 1 and 3 Plan (sorted by administration)**

1	2	3	4		5			6	7	8		9	10		11	12	13	14	15	16
			Orbital position	Boresight		Space station antenna characteristics				Space station antenna code	Shaped beam		Space station antenna gain							
Beam identification	Long.	Lat.		Major axis	Minor axis	Orientation	Co-polar	Cross-polar	Code			Gain	Type	Angle	e.i.r.p.					
AFG	AUS-100	50.00	65.88	33.96											58.3 Z7M0G7W				P	
AFS	AFS02700	4.80	24.50	-28.00	3.13	1.88	17.00	R13TSS							MODRES 35.50 CL					P
AGL	AGL29600	-24.80	16.06	-12.45	2.42	1.88	77.00	R13TSS							MODRES 35.50 CL					P
ALB	ALB29600	62.00	20.94	41.23	0.60	0.60	61.32	R13TSS							MODRES 35.50 CL					P
ALG	ALG 100	-24.80	1.86	27.60				CB TSS ALGA							MODRES 35.50 CL					P
AND	AND04100	-37.00	1.60	42.50	0.60	0.60	0.00	R13TSS							MODRES 35.50 CL					P
ARM	ARM08400	22.00	44.99	39.95	0.73	0.60	148.17	R13TSS							MODRES 35.50 CR					P
ARS	ARS 100	17.00	44.72	23.76				CB TSS ARSA							MODRES 35.50 CL					P
ARS	ARS34000	17.00	52.30	24.80	2.68	0.70	143.00	R13TSS							MODRES 35.50 CL					P
AUS	AUS00400	152.00	123.00	-24.20	3.06	2.17	102.00	R13TSS							MODRES 35.50 CR					P
AUS	AUS0040A	152.00	98.83	-12.19	0.60	0.60	0.00	R13TSS							MODRES 35.50 CR					P
AUS	AUS0040B	152.00	106.69	-10.45	0.60	0.60	0.00	R13TSS							MODRES 35.50 CR					P
AUS	AUS00500	152.00	110.52	-66.28	0.60	0.60	0.00	R13TSS							MODRES 35.50 CR					P
AUS	AUS00500	152.00	139.90	-18.40	2.82	1.74	105.00	R13TSS							MODRES 35.50 CL					P
AUS	AUS00600	152.00	136.60	-30.90	2.41	1.52	161.00	R13TSS							MODRES 35.50 CL					P
AUS	AUS00700	164.00	145.20	-36.10	2.12	1.02	147.00	R13TSS							MODRES 35.50 CR					P
AUS	AUS0070A	164.00	158.94	-84.50	0.60	0.60	0.00	R13TSS							MODRES 35.50 CR					P
AUS	AUS00800	164.00	145.90	-21.70	3.62	1.63	136.00	R13TSS							MODRES 35.50 CL					P
AUS	AUS00900	164.00	147.50	-32.10	2.31	1.43	187.00	R13TSS							MODRES 35.50 CR					P
AUS	AUS0090A	164.00	159.06	-31.52	0.60	0.60	0.00	R13TSS							MODRES 35.50 CR					P
AUS	AUS0090B	164.00	167.93	-29.02	0.60	0.60	0.00	R13TSS							MODRES 35.50 CR					P
AUS	AUS 100	152.00	132.38	-38.37				CB TSS AUSA							MODRES 35.50 CR					P
AUS	AUS 100	164.00	132.38	-38.37				CB TSS AUSA							MODRES 35.50 CR					P
AUS	AUS 100	164.00	103.31	49.47	1.82	0.92	151.76	MOD49TRSS							MODRES 35.50 CR					P
AZE	AZE16400	23.20	47.47	40.14	0.93	0.60	158.14	R13TSS							MODRES 35.50 CR					P
BDI	BDI02700	11.00	29.90	-3.10	0.71	0.60	30.00	R13TSS							MODRES 35.50 CL					P
BEL	BEL01800	38.20	5.12	12.66	1.00	1.00	24.63	MOD49TRSS							MODRES 35.50 CL					P
BFA	BFA23300	-19.20	2.26	0.50	1.44	0.68	67.00	R13TSS							MODRES 35.50 CL					P
BFA	BFA15000	-30.00	-1.50	12.20	1.46	1.14	29.00	R13TSS							MODRES 35.50 CL					P
BGD	BGD22000	74.00	50.30	22.60	1.46	0.84	135.00	R13TSS							MODRES 35.50 CR					P
BHR	BHR26500	34.00	59.50	28.10	0.60	0.60	0.00	MOD49TRSS							MODRES 35.50 CR					P
BH	BH14600	96.00	19.22	43.97	0.60	0.60	90.00	R13TSS							MODRES 35.50 CR					P
BLR	BLR02600	-37.80	21.91	53.06	1.21	0.60	11.47	R13TSS							MODRES 35.50 CL					P
BOT	BOT27900	-0.80	23.80	-22.20	2.13	1.50	36.00	R13TSS							MODRES 35.50 CR					P
BRM	BRM29900	104.00	96.97	18.67	3.33	1.66	91.58	R13TSS							MODRES 35.50 CR					P
BRU	BRU03000	74.00	114.70	4.40	0.60	0.60	0.00	R13TSS							MODRES 35.50 CR					P
BTN	BTN03100	86.00	90.44	27.05	0.72	0.60	175.47	R13TSS							MODRES 35.50 CR					P
BUL	BUL02000	-1.20	25.00	43.00	1.04	0.60	165.00	R13TSS							MODRES 35.50 CR					P
CAF	CAF29800	-13.20	21.00	6.30	2.25	1.68	31.00	R13TSS							MODRES 35.50 CL					P
CBG	CBG29900	86.00	104.82	12.34	1.04	0.86	9.45	R13TSS							MODRES 35.50 CR					P

1	2	3	4		5			6	7	8		9		10	11	12	13	14	15	16
			Orbital position	Boresight		Space station antenna characteristics				Space station antenna code	Shaped beam	Space station antenna gain								
Long.	Lat.	Major axis		Minor axis	Orientation	Co-polar	Cross-polar	Code	Gain			Type	Angle							
CHN	CHN15500	62.00	88.18	31.20	3.03	1.24	163.23	R13TSS		38.69		MODRES	35.50	CL	57.9	27M0G7W				P
CHN	CHN15600	134.00	132.29	39.70	2.80	1.58	35.44	R13TSS		39.07		MODRES	35.50	CR	57.9	27M0G7W				P
CHN	CHN15700	122.00	114.17	23.32	0.91	0.80	2.86	MOD3FRTSS		47.08		MODRES	35.50	CR	58.3	27M0G7W				P
CHN	CHN20000	122.00	113.95	22.20	0.80	0.80	0.00	MOD3FRTSS		48.88		MODRES	35.50	CL	57.9	27M0G7W				P
CHN	CHN21000	62.00	90.96	39.22				CB TSS CHINA		40.01		MODRES	35.50	CL	58.5	27M0G7W				P
CHN	CHN21100	134.00	105.77	27.56				CB TSS CHINE		39.51		MODRES	35.50	CL	59.4	27M0G7W				P
CHN	CHN21200	92.20	114.96	20.16				CB TSS CHNF		44.74		MODRES	35.50	CL	60.4	27M0G7W				P
CHN	CHN21300	92.20	123.54	45.78				CB TSS CHNF		43.71		MODRES	35.50	CR	56.7	27M0G7W				P
CHN	CHN21400	50.00	80.60	7.70	1.18	0.60	106.00	R13TSS		45.95		MODRES	35.50	CL	56.7	27M0G7W				P
CHN	CHN21500	-13.00	12.70	6.20	2.54	1.68	87.00	R13TSS		38.15		MODRES	35.50	CR	58.3	27M0G7W				P
CHN	CHN21600	-19.20	21.85	-3.40				CB TSS CODA		38.36		MODRES	35.50	CR	59.7	27M0G7W				P
COM	COM23000	-13.20	14.60	-0.70	2.02	1.18	59.00	R13TSS		40.67		MODRES	35.50	CR	58.3	27M0G7W				P
COM	COM23100	29.00	44.10	-12.10	0.76	0.60	149.00	R13TSS		47.86		MODRES	35.50	CR	58.1	27M0G7W				P
COM	COM23200	-33.50	-24.12	16.09	0.77	0.63	94.46	R13TSS		47.56		MODRES	35.50	CR	57.4	27M0G7W				P
CPV	CPV30100	-24.80	-5.78	7.19	1.50	1.14	11.74	R13TSS		41.67		MODRES	35.50	CL	58.8	27M0G7W				P
CTI	CTI23700	-1.20	13.02	42.09	0.75	0.66	20.53	R13TSS		40.92		MODRES	35.50	CR	60.3	27M0G7W				P
CVA	CVA08300	-1.20	12.59	41.09	1.72	1.31	144.13	MOD3FRTSS		49.92		MODRES	35.50	CR	56.4	27M0G7W				5, 7
CVA	CVA08300	-1.20	33.45	35.12	0.60	0.60	0.00	MOD3FRTSS		48.88		MODRES	35.50	CR	56.4	27M0G7W				5, 7
CYP	CYP08600	-12.80	16.77	46.78	1.71	0.89	149.15	MOD3FRTSS		42.64		MODRES	35.50	CL	58.8	27M0G7W				P
CZE	CZE14401	-12.80	16.77	46.78	1.71	0.89	149.15	MOD3FRTSS		42.64		MODRES	35.50	CR	58.8	27M0G7W				P
CZE	CZE14402	-12.80	16.77	46.78	1.71	0.89	149.15	MOD3FRTSS		42.64		MODRES	35.50	CR	58.8	27M0G7W				37
D	D 08700	-18.80	10.31	49.47	1.82	0.92	151.78	MOD3FRTSS		42.19		MODRES	35.50	CR	59.1	27M0G7W				P
DJI	DJI09900	16.80	42.68	11.68	0.60	0.60	90.00	R13TSS		48.88		MODRES	35.50	CL	57.9	27M0G7W				P
DNK	DNK 100	-25.20	2.92	59.62				CB TSS DNKA		48.88		MODRES	35.50	CL	58.3	27M0G7W				P
DNK	DNK091XR	-33.50	13.27	60.86	1.99	0.63	151.38	MOD3FRTSS		43.48		MODRES	35.50	CR	54.9	27M0G7W				6
DNK	DNK091XR	-33.50	-15.16	63.67	1.56	0.60	170.63	MOD3FRTSS		44.73		MODRES	35.50	CR	58.3	27M0G7W				P
DNK	DNK091XR	-33.50	-9.40	34.15				CB TSS E-A		44.79		MODRES	35.50	CR	58.3	27M0G7W				01
E	E 100	-30.00	-4.00	39.00				COP		39.80		MODRES	35.50	CL	57.8	13M0G7W	HISPASAT-1			PE
E	HSP3301	-30.00	-4.00	39.00				COP		39.80		MODRES	32.50	CL	57.8	13M0G7W	HISPASAT-1			01
E	HSP3270	-30.00	-4.00	39.00				COP		39.80		MODRES	38.43	CL	57.9	27M0G7W	HISPASAT-1			01
E	HSP3270	-30.00	-4.00	39.00				COP		39.80		MODRES	38.43	CL	57.9	27M0G7W	HISPASAT-1			01
E	HSP3270	-30.00	-4.00	39.00				COP		39.80		MODRES	38.43	CL	57.9	27M0G7W	HISPASAT-1			01
EGY	EGY03690	-7.00	28.70	36.30	2.33	1.72	136.00	R13TSS		38.42		MODRES	35.50	CL	58.3	27M0G7W				8
EST	EST06200	22.80	38.41	14.98	1.61	0.95	145.48	R13TSS		42.44		MODRES	35.50	CR	58.3	27M0G7W				P
EST	EST106100	44.30	23.96	58.60	0.71	0.60	172.7	R13TSS		47.81		MODRES	35.50	CR	58.1	27M0G7W				P
ETH	ETH05200	36.00	40.29	8.95	2.61	2.16	174.06	R13TSS		38.52		MODRES	35.50	CL	58.1	27M0G7W				P
F	F 09300	-7.00	3.52	45.41	2.22	1.15	195.94	R13TSS		40.39		MODRES	35.50	CL	58.3	27M0G7W				21
F	F 100	-7.00	50.00	-15.65				CB TSS F-A		48.88		MODRES	35.50	CR	58.3	27M0G7W				P
F	NCL10000	-140.00	166.00	-27.00	1.14	0.72	146.00	R13TSS		45.30		MODRES	35.50	CR	58.1	27M0G7W				P
F	OCE101000	-160.00	-145.00	-16.30	4.34	3.54	4.00	R13TSS		32.58		MODRES	35.50	CR	58.1	27M0G7W				P
F	VAL10200	140.00	-176.80	-14.00	0.74	0.60	29.00	R13TSS		47.97		MODRES	35.50	CR	59.4	27M0G7W				P
FIN	FIN10300	22.80	25.50	64.50	1.38	0.76	171.00	MOD3FRTSS		44.24		MODRES	35.50	CL	54.9	27M0G7W				52
FIN	FIN10400	22.80	16.87	61.15	2.24	0.91	167.00	MOD3FRTSS		41.37		MODRES	35.50	CL	54.9	27M0G7W				52
FJI	FJI19300	-178.00	179.62	-17.87	1.16	0.92	155.22	R13TSS		44.16		MODRES	35.50	CR	58.1	27M0G7W				P
FJM	FSM00000	168.00	151.90	5.48	5.15	4.57	167.00	R13TSS		38.38		MODRES	35.50	CR	58.9	27M0G7W				7
G	G 02700	-33.50	-3.50	53.80	1.84	0.72	142.00	R13TSS		43.23		MODRES	35.50	CR	58.0	27M0G7W				P

1	2	3	4		5			6	7	8		9		10	11	12	13	14	15	16	
			Beam identification	Orbital position	Bore-sight		Space station antenna characteristics			Space station antenna code	Shaped beam	Space station antenna gain									Earth station antenna
Long.	Lat.	Major axis			Minor axis	Ori-entation	Co-pol-ular	Cross-pol-ular	Code			Gain	Type	Angle	Designation of emission	e.l.r.p.					
GAB	GAB26000	-43.20	11.80	-0.60	1.43	1.12	64.00	R13TSS			42.40		MODRES	35.50	CR		58.3	27M0G7W		P	
GEO	GEO09400	23.20	43.35	42.71	1.11	0.60	161.21	R13TSS			42.63		MODRES	35.50	CR		58.3	27M0G7W		P	
GHA	GHA10800	-4.20	7.50	1.46	1.06	102.00	R13TSS			42.49		MODRES	35.50	CR		58.3	27M0G7W		P		
GMB	GMB50200	-37.20	-15.10	13.40	0.79	0.80	4.00	R13TSS			47.69		MODRES	35.50	CL		58.3	27M0G7W		P	
GMB	GMB50200	-37.20	-15.00	12.40	0.90	0.80	172.00	R13TSS			47.12		MODRES	35.50	CL		58.3	27M0G7W		P	
GNE	GNE89400	-18.80	10.30	1.50	0.88	0.80	10.00	R13TSS			48.34		MODRES	35.50	CL		58.3	27M0G7W		P	
GRC	GRC19500	-1.20	24.51	38.08	1.70	0.95	152.97	MOD13FR1SS			42.40		MODRES	35.50	CL		58.3	27M0G7W		P	
GJY	GJY19200	-37.00	-11.00	10.20	1.58	1.04	147.00	R13TSS			42.29		MODRES	35.50	CR		58.3	27M0G7W		P	
HNG	HNG10601	-12.80	16.77	46.78	1.71	0.89	149.15	MOD13FR1SS			42.64		MODRES	35.50	CR		58.3	27M0G7W		P	
HNG	HNG10602	-12.80	16.77	46.78	1.71	0.89	149.15	MOD13FR1SS			42.64		MODRES	35.50	CR		58.3	27M0G7W		P	
HNG	HNG10603	-12.80	16.77	46.78	1.71	0.89	149.15	MOD13FR1SS			42.64		MODRES	35.50	CR		58.3	27M0G7W		P	
HOL	HOL21300	38.20	5.12	51.96	1.00	1.00	24.53	MOD13FR1SS			44.45		MODRES	35.50	CL		58.3	27M0G7W		P	
HRV	HRV14801	-12.80	16.77	46.78	1.71	0.89	149.15	MOD13FR1SS			42.64		MODRES	35.50	CL		58.3	27M0G7W		P	
HRV	HRV14802	-12.80	16.77	46.78	1.71	0.89	149.15	MOD13FR1SS			42.64		MODRES	35.50	CR		58.3	27M0G7W		P	
HRV	HRV14803	-12.80	16.77	46.78	1.71	0.89	149.15	MOD13FR1SS			42.64		MODRES	35.50	CR		58.3	27M0G7W		P	
IND	IND03700	66.00	9.00	12.67	40.74	1.99	1.35	144.20	R13TSS		40.14		MODRES	35.50	CR		54.5	27M0G7W		P	
IND	IND04700	66.00	93.00	25.50	1.46	1.13	40.00	R13TSS			42.27		MODRES	35.50	CL		58.3	27M0G7W		P	
IND	IND04700	66.00	93.30	11.10	1.92	0.60	96.00	R13TSS			43.83		MODRES	35.50	CR		58.4	27M0G7W		P	
IND	INDA	55.80	76.16	14.72				CE TSS INDIA			45.66		MODRES	35.50	CR		58.4	27M0G7W		P	
IND	INDB	55.80	83.43	24.22				CE TSS INDB			43.15		MODRES	35.50	CL		58.3	27M0G7W		P	
IND	INDC	66.00	74.37	29.16				CE TSS INDC			41.80		MODRES	35.50	CR		58.3	27M0G7W		P	
INS	NSA	80.20	108.82	-0.73				CE TSS INSA			38.88		MODRES	35.50	CR		58.3	27M0G7W		P	
INS	NSB	100.00	129.75	-3.50				CE TSS INSB			37.53		MODRES	35.50	CL		58.3	27M0G7W		P	
IRL	IRL21100	-37.20	-8.25	53.22	0.72	0.60	157.56	R13TSS			48.08		MODRES	35.50	CL		59.2	27M0G7W		P	
IRN	IRN10900	34.00	54.20	32.40	3.82	1.82	149.00	R13TSS			36.03		MODRES	35.50	CL		57.8	27M0G7W		P	
IRQ	IRQ25600	50.00	43.78	33.28	1.74	1.23	156.76	R13TSS			41.14		MODRES	35.50	CL		58.3	27M0G7W		P	
ISL	ISL04900	-33.50	-19.00	64.90	1.00	0.60	177.00	R13TSS			46.67		MODRES	35.50	CR		60.8	27M0G7W		P	
ISL	ISL051000	-33.50	-15.35	63.25	1.58	0.60	169.00	R13TSS			44.67		MODRES	35.50	CR		57.3	27M0G7W		P	
ISR	ISR1	-4.00	34.95	31.32	0.73	0.60	110.02	R13TSS			48.01		MODRES	35.50	CR		58.3	27M0G7W		P	
J	J008S-3N	109.85	134.50	31.50	3.52	3.30	68.00	R13TSS			33.80		MODRES	35.50	CR		BS-3N	02	PE		
J	J109S	109.85	134.50	31.50	3.52	3.30	68.00	R13TSS			33.80		MODRES	35.50	CR		BS-3N	02	PE		
J	J110S	110.00	134.50	31.50	3.52	3.30	68.00	R13TSS			33.80		MODRES	35.50	CR		BS-3M	02	PE		
J	J110E	110.00	134.50	31.50	3.52	3.30	68.00	R13TSS			33.80		MODRES	35.50	CR		BS-3M	02	PE		
JOR	JOR22400	11.00	37.95	34.02	1.47	0.91	73.76	MOD13FR1SS			43.19		MODRES	35.50	CL		55.3	27M0G7W		P	
KAZ	KAZ20600	56.40	59.73	46.40	4.58	1.76	177.45	R13TSS			35.38		MODRES	35.50	CR		58.3	27M0G7W		P	
KEN	KEN24900	-0.80	37.95	0.52	2.13	1.34	96.35	R13TSS			39.90		MODRES	35.50	CR		58.3	27M0G7W		P	
KGZ	KGZ27000	50.00	73.91	41.32	1.47	0.64	5.05	R13TSS			44.75		MODRES	35.50	CR		58.3	27M0G7W		P	
KIR	KIR-100	16.00	-170.31	-0.56				CE TSS KIRA			42.58		MODRES	35.50	CL		58.3	27M0G7W		P	
KOR	KOR12001D	116.00	127.50	36.00	1.24	1.02	168.00	R13TSS			43.40		MODRES	38.43	CL		**#	27M0G7W	KOREASAT-1	103	PE

\* Channel 1: 58.2 dBW, channels 3, 5, 7, 59.2 dBW, channels 9, 11, 13; 59.3 dBW, other channels: 59.4 dBW.  
 \*\* Channels 2, 4, 6: 63.6 dBW, channels 8, 10, 12: 63.7 dBW.

1	2	3	4		5			6	7	8		9		10	11	12	13	14	15	16	
			Boresight		Space station antenna characteristics					Space station antenna gain		Earth station antenna									Polarization
Admin. Symbol	Beam identification	Orbital position	Long.	Lat.	Major axis	Minor axis	Orientation	Space station antenna code	Shaped beam	Co-polar	Cross-polar	Code	Gain	Type	Angle	e.i.r.p.	Designation of emission	Identity of the space station	Group code	Status	Remarks
KOR	KOR11200	116.00	47.50	38.00	1.24	1.02	168.00	R13TSS		43.80		MODRES	35.50	CL		**+*	27M0G7W		03	P	
KOR	KOR11201	116.00	72.30	38.00	1.24	1.02	168.00	R13TSS		43.40		MODRES	35.50	CL		**+*	27M0G7W	KOREASAT-1	03	PE	
KRE	KRE26600	140.00	128.45	40.32	1.63	0.68	16.69	R13TSS		48.00		MODRES	35.50	CL		59.0	27M0G7W			P	
KWT	KWT11300	11.00	47.48	29.72	0.60	0.60	90.00	R13TSS		48.88		MODRES	35.50	CR		58.2	27M0G7W			P	
LAO	LAO28400	122.20	103.71	18.71	1.03	1.23	99.00	MOD13FR1SS		41.60		MODRES	35.50	CR		58.9	33M0G7W			P	
LBN	LBN27900	11.00	37.55	34.02	1.47	0.91	73.16	MOD13FR1SS		43.19		MODRES	35.50	CR		58.5	27M0G7W			P	
LBR	LBR24000	-33.50	-9.30	6.60	1.22	0.70	133.00	R13TSS		45.13		MODRES	35.50	CR		58.2	27M0G7W			P	
LBV	LBV 100	-24.80	17.62	26.55				CB TSS LBVA		40.30		MODRES	35.50	CL		59.0	27M0G7W			P	
LIE	LIE25300	-18.00	10.31	49.47	1.82	0.92	151.78	MOD13FR1SS		42.19		MODRES	35.50	CL		58.1	27M0G7W			P	
LTO	LTO30900	4.80	27.80	-29.80	0.66	0.60	36.00	R13TSS		48.47		MODRES	35.50	CR		59.2	27M0G7W			P	
LTU	LTU06100	23.20	24.51	56.09				CB TSS LTUA		48.21		MODRES	35.50	CL		56.8	27M0G7W			P	
LUX	LUX11400	28.20	5.21	49.20	0.60	0.60	90.00	R13TSS		48.88		MODRES	35.50	CR		57.8	27M0G7W		09	P	
LVA	LVA6100	23.20	24.51	56.09				CB TSS LVAA		48.21		MODRES	35.50	CR		56.8	27M0G7W			P	
MAU	MAU 100	29.00	58.61	-15.88				CB TSS MAUA		41.42		MODRES	35.50	CL		59.0	27M0G7W			P	
MCO	MCO11600	34.20	7.93	43.59	1.28	0.60	21.73	MOD13FR1SS		45.58		MODRES	35.50	CL		58.6	27M0G7W			P	
MDA	MDA06300	50.00	28.45	46.99	0.60	0.60	90.00	R13TSS		48.88		MODRES	35.50	CR		58.9	27M0G7W			P	
MDG	MDG32600	29.00	46.60	-18.80	2.72	1.14	65.00	R13TSS		39.53		MODRES	35.50	CL		58.9	27M0G7W			P	
MHL	MHL00000	146.00	167.64	9.83	2.07	0.90	157.42	R13TSS		41.75		MODRES	35.50	CR		59.0	27M0G7W			P	
MKD	MKD14800	22.80	21.61	41.56	0.60	0.60	90.00	R13TSS		48.88		MODRES	35.50	CR		58.9	27M0G7W			P	
MLA	MLA 100	91.50	108.05	4.00				CB TSS MLAA		43.00		MODRES	35.50	CR		58.4	27M0G7W			P	
MLD	MLD00600	50.00	72.95	5.78	1.19	0.91	104.53	R13TSS		44.09		MODRES	35.50	CR		58.7	27M0G7W			P	
MLI	MLI 100	-19.20	-5.35	17.11				CB TSS MLIB		41.21		MODRES	35.50	CR		58.7	27M0G7W			P	5
MLT	MLT14700	22.80	14.40	35.90	0.60	0.60	0.00	R13TSS		48.88		MODRES	35.50	CR		56.0	27M0G7W			P	
MNG	MNG24800	74.00	102.20	46.60	3.60	1.13	169.00	R13TSS		38.35		MODRES	35.50	CR		59.0	27M0G7W			P	5,7
MOZ	MOZ30700	-1.00	34.00	-18.00	3.57	1.38	55.00	R13TSS		37.52		MODRES	35.50	CL		59.2	27M0G7W			P	5,7
MRC	MRC29600	-25.20	-9.95	28.98	3.56	1.23	49.23	R13TSS		38.02		MODRES	35.50	CR		54.9	27M0G7W			P	
MTN	MTN 100	-36.80	-10.92	19.66				CB TSS MTNA		41.91		MODRES	35.50	CR		59.3	27M0G7W			P	7
MWI	MWI03800	4.80	33.76	-13.25	1.56	0.70	92.69	R13TSS		44.10		MODRES	35.50	CR		59.2	27M0G7W			P	
MWR	MWR11500	-37.20	7.63	17.61	2.20	1.80	102.40	R13TSS		38.48		MODRES	35.50	CL		58.9	27M0G7W			P	
NIG	NIG11900	-18.00	17.60	9.40	2.02	0.45	0.00	R13TSS		39.05		MODRES	35.50	CR		58.9	27M0G7W			P	5,7
NAB	NAB25500	-18.00	17.50	-21.60	2.68	1.60	48.00	R13TSS		37.41		MODRES	35.50	CL		59.2	27M0G7W			P	
NOR	NOR12000	-9.80	18.42	62.76	1.43	0.60	19.61	MOD13FR1SS		45.10		MODRES	35.50	CL		56.2	27M0G7W		06	P	
NOR	NOR12100	-9.80	18.00	60.23	1.91	0.63	23.65	R13TSS		43.02		MODRES	35.50	CL		57.8	27M0G7W		06	P	
NPL	NPL12200	50.00	67.30	28.30	1.72	0.60	163.00	R13TSS		44.31		MODRES	35.50	CL		59.6	27M0G7W			P	
NRU	NRU039500	134.00	167.00	-0.50	0.60	0.60	0.00	R13TSS		48.88		MODRES	35.50	CL		57.8	27M0G7W			P	
NZL	NZL 100	158.00	-170.88	-19.72				CB TSS NZLA		48.88		MODRES	35.50	CR		59.3	27M0G7W			P	
OMA	OMA12300	17.20	55.80	21.00	1.88	1.02	100.00	R13TSS		41.62		MODRES	35.50	CR		58.9	27M0G7W			P	
PAK	PAK17700	36.20	69.60	29.50	2.30	2.16	14.00	R13TSS		37.49		MODRES	35.50	CL		58.7	27M0G7W			P	
PHL	PHL28500	98.00	121.30	11.10	3.46	1.76	99.00	R13TSS		36.60		MODRES	35.50	CR		58.7	27M0G7W			P	
PLW	PLW00000	140.00	132.98	5.51	1.30	0.60	55.41	R13TSS		45.53		MODRES	35.50	CR		58.9	27M0G7W			P	
PNG	PNG15100	134.00	148.07	-6.65	3.13	2.30	168.32	MOD13FR1SS		35.87		MODRES	35.50	CR		54.9	27M0G7W			P	
POL	POL13200	50.00	20.07	-51.86	1.20	0.69	117.76	R13TSS		45.26		MODRES	35.50	CL		59.2	27M0G7W			P	

\*\*\* Channels 2, 4, 6: 590 dBW, other channels: 59.1 dBW.

1	2	3	4		5			7	8		9		10	11	12	13	14	15	16	
			Beam identification	Orbital position	Bore-sight	Space station antenna characteristics	Space station antenna code		Shaped beam	Space station antenna gain	Co-polar	Cross-polar								Earth station antenna
Admin. Symbol	Beam identification	Orbital position	Long.	Lat.	Major axis	Minor axis	Orientation	Space station antenna code	Shaped beam	Co-polar	Cross-polar	Code	Gain	Type	Angle	Designation of emission	Identity of the space station	Group code	Status	Remarks
ROR	POR_100	-37.00	-15.92	37.65				CE ISS POR4		41.17		MOORES	35.50	CR		58.4 27M0G7W			P	5, 7
PSE	TY100000	-15.20	34.99	31.86	0.60	0.60	90.00	MOORES R131SS		48.88		MOORES	35.50	CL		58.3 27M0G7W			P	3
GAT	GAT24700	20.00	51.38	25.26	0.60	0.60	90.00	MOORES R131SS		48.88		MOORES	35.50	CL		54.3 27M0G7W			P	
ROU	ROU19600	50.00	25.12	45.75	1.17	0.73	9.52	MOORES R131SS		48.45		MOORES	35.50	CR		58.3 27M0G7W			P	
RHW	RHW61000	11.00	30.00	-2.10	0.68	0.60	42.00	MOORES R131SS		48.47		MOORES	35.50	CL		58.3 27M0G7W			P	
RUS	RSTREA21	36.00	38.00	53.00	2.20	2.20	0.00	MOORES R131SS		37.70		MOORES	35.50	CL		53.0 27M0G7W RST-1		05	PE	
RUS	RSTREA22	36.00	38.00	53.00	2.20	2.20	0.00	MOORES R131SS		37.70		MOORES	35.50	CL		53.0 27M0G7W RST-1		05	PE	
RUS	RSTRED11	36.00	38.00	53.00	2.20	2.20	0.00	MOORES R131SS		37.70		MOORES	35.50	CR		53.0 27M0G7W RST-1		05	PE	
RUS	RSTRED12	36.00	38.00	53.00	2.20	2.20	0.00	MOORES R131SS		37.70		MOORES	35.50	CR		53.0 27M0G7W RST-1		05	PE	
RUS	RSTRED13	36.00	38.00	53.00	2.20	2.20	0.00	MOORES R131SS		37.70		MOORES	35.50	CR		53.0 27M0G7W RST-1		05	PE	
RUS	RSTRED14	36.00	38.00	53.00	2.20	2.20	0.00	MOORES R131SS		37.70		MOORES	35.50	CR		53.0 27M0G7W RST-1		05	P	
RUS	RSTRED21	56.00	65.00	63.00	2.20	2.20	0.00	MOORES R131SS		37.70		MOORES	39.02	CL		53.0 27M0G7W RST-1		05	P	
RUS	RSTRED22	56.00	65.00	63.00	2.20	2.20	0.00	MOORES R131SS		37.70		MOORES	35.50	CR		55.0 27M0G7W RST-2		14	P	
RUS	RSTRED31	86.00	97.00	62.00	2.20	2.20	0.00	MOORES R131SS		37.70		MOORES	35.50	CR		55.0 27M0G7W RST-3		14	P	
RUS	RSTRED32	86.00	97.00	62.00	2.20	2.20	0.00	MOORES R131SS		37.70		MOORES	35.50	CL		55.0 27M0G7W RST-3		33	P	
RUS	RSTRED51	140.00	158.00	96.00	2.20	2.20	0.00	MOORES R131SS		37.70		MOORES	35.50	CR		55.0 27M0G7W RST-3		33	P	
RUS	RSTRED52	140.00	158.00	96.00	2.20	2.20	0.00	MOORES R131SS		37.70		MOORES	35.50	CL		55.0 27M0G7W RST-3		35	P	
RUS	RUS00401	110.00	128.73	54.30	4.25	2.02	156.81	MOORES R131SS		35.11		MOORES	35.50	CL		58.9 27M0G7W RST-5		35	P	5, 7, 8
RUS	RUS00402	110.00	128.73	54.30	4.25	2.02	156.81	MOORES R131SS		35.11		MOORES	35.50	CR		58.9 27M0G7W RUS-4		34	P	5, 7, 8
S	S_13800	5.00	16.20	61.00	1.04	0.98	16.20	MOORES R131SS		44.36		MOORES	35.50	CL		55.8 27M0G7W RUS-4		04	P	
S	S_13900	5.00	17.00	61.50	2.00	1.00	10.00	MOORES R131SS		41.44		MOORES	35.50	CL		61.1 27M0G7W RUS-4		04	P	
SDN	SDN_100	-7.00	30.24	13.53				CE ISS SDNA		40.26		MOORES	35.50	CR		59.4 27M0G7W RUS-4		04	P	
SEN	SEV2200	-37.00	-14.40	13.80	1.46	1.04	139.00	MOORES R131SS		42.63		MOORES	35.50	CL		58.9 27M0G7W RUS-4			P	5, 7
SEY	SEV00000	42.50	51.86	-7.23	2.43	1.04	27.51	MOORES R131SS		40.44		MOORES	35.50	CR		58.3 27M0G7W RUS-4			P	
SILM	SILM00000	128.00	159.27	-8.40	1.35	1.08	118.59	MOORES R131SS		42.81		MOORES	35.50	CR		58.3 27M0G7W RUS-4			P	
SINR	SINR57000	-178.00	-113.87	-13.87	0.60	0.60	90.00	MOORES R131SS		48.88		MOORES	35.50	CR		58.9 27M0G7W RUS-4			P	7
SNR	SNR31100	-36.80	19.60	43.70	0.60	0.60	0.00	MOORES R131SS		48.88		MOORES	35.50	CR		57.4 27M0G7W RUS-4			P	7
SNS	SNG15100	86.00	103.86	1.42	0.92	0.72	175.12	MOORES R131SS		46.26		MOORES	35.50	CR		58.3 27M0G7W RUS-4			P	
SON	SON41200	37.80	45.16	7.11	3.31	1.51	65.46	MOORES R131SS		37.46		MOORES	35.50	CR		57.7 27M0G7W RUS-4			P	5
SRB	SRB16800	-7.00	29.50	43.98	0.91	0.60	145.16	MOORES R131SS		41.07		MOORES	35.50	CR		58.3 27M0G7W RUS-4			P	
SRL	SRL23800	-33.50	-11.80	8.60	0.78	0.68	114.00	MOORES R131SS		41.20		MOORES	35.50	CR		58.3 27M0G7W RUS-4			P	6
SIP	SIP24100	-7.00	6.17	1.45	0.65	0.60	133.51	MOORES R131SS		48.36		MOORES	35.50	CR		58.4 27M0G7W RUS-4			P	
SJF	SJF21000	-16.80	10.31	49.47	1.62	0.92	151.78	MOODJFR1SS		42.19		MOORES	35.50	CL		59.3 27M0G7W RUS-4			P	
SJK	SJK14401	-12.80	16.77	46.78	1.71	0.89	149.15	MOODJFR1SS		42.84		MOORES	35.50	CR		59.3 27M0G7W RUS-4			P	
SJK	SJK14402	-12.80	16.77	46.78	1.71	0.89	149.15	MOODJFR1SS		42.84		MOORES	35.50	CR		59.3 27M0G7W RUS-4			P	
SJK	SJK14403	-12.80	16.77	46.78	1.71	0.89	149.15	MOODJFR1SS		42.84		MOORES	35.50	CR		59.3 27M0G7W RUS-4			P	37
SJN	SJN116000	33.80	15.01	46.18	0.60	0.60	90.00	MOORES R131SS		48.88		MOORES	35.50	CL		58.9 27M0G7W RUS-4			P	
SNZ	SNZ21300	4.80	31.39	-26.44	0.60	0.60	90.00	MOORES R131SS		48.88		MOORES	35.50	CL		57.9 27M0G7W RUS-4			P	
SVR	SVR22900	11.00	37.55	34.02	1.47	0.91	73.16	MOODJFR1SS		43.19		MOORES	35.50	CR		56.5 27M0G7W RUS-4		53	P	
SVR	SVR33500	11.00	37.60	34.20	1.32	0.88	74.00	MOODJFR1SS		43.19		MOORES	35.50	CL		56.4 27M0G7W RUS-4		53	P	
TCD	TCD14300	17.00	18.36	15.47	3.23	2.05	62.89	MOODJFR1SS		36.23		MOORES	35.50	CR		58.9 27M0G7W RUS-4			P	
TGO	TGO22600	-30.00	0.72	8.61	1.12	0.60	109.54	MOORES R131SS		46.19		MOORES	35.50	CR		58.5 27M0G7W RUS-4			P	5, 7

1	2	3	4		5			6	7	8		9		10	11	12	13	14	15	16
			Boresight		Space station antenna characteristics					Space station antenna code	Shaped beam	Space station antenna gain	Earth station antenna							
Admin. symbol	Beam identification	Orbital position	Long.	Lat.	Major axis	Minor axis	Orientation	Space station antenna code	Shaped beam	Co-polar	Cross-polar	Code	Gain	Type	Angle	e.i.r.p.	Designation of emission	Identity of the space station	Status	Remarks
THA	THA14200	98.00	100.75	12.88	2.80	1.82	93.77	R13TSS		37.37		MODRES	35.50	CL		58.3	Z7M0G7W		P	
UK	UK065900	36.00	70.14	38.41	2.21	0.73	155.31	R13TSS		46.00		MODRES	35.50	CL		58.3	Z7M0G7W		P	5
PKM	PKM006500	50.00	59.24	38.63	2.26	1.02	166.64	R13TSS		46.81		MODRES	35.50	CR		58.3	Z7M0G7W		P	5
ILS	ILS030000	126.00	-126.03	-8.72	0.66	0.60	13.52	R13TSS		46.80		MODRES	35.50	CR		58.3	Z7M0G7W		P	
TON	TON21500	170.75	-175.23	-18.19	1.58	0.60	71.33	R13TSS		44.64		MODRES	35.50	CR		58.3	Z7M0G7W		P	5
TUN	TUN193000	-25.20	9.50	33.50	1.88	0.72	135.00	MOD19FR1SS		43.13		MODRES	35.50	CR		57.4	Z7M0G7W		P	4
TUN	TUN27200	42.00	2.10	31.75	3.41	1.81	179.18	MOD19FR1SS		36.54		MODRES	35.50	CR		55.8	Z7M0G7W		P	
TUR	TUR14500	47.00	34.95	39.09	3.18	0.99	0.79	R13TSS		39.47		MODRES	35.50	CL		58.4	Z7M0G7W		P	36
TUV	TUV000000	176.00	177.61	-7.11	0.94	0.60	137.58	R13TSS		46.93		MODRES	35.50	CR		58.9	Z7M0G7W		P	
TZA	TZA29500	11.00	34.60	-6.20	2.41	1.72	129.00	R13TSS		38.27		MODRES	35.50	CR		58.4	Z7M0G7W		P	
UAE	UAE27400	62.50	53.85	24.34	1.19	0.85	3.72	R13TSS		44.39		MODRES	35.50	CR		58.4	Z7M0G7W		P	
UGA	UGA045100	17.00	32.20	1.04	1.50	1.02	68.73	R13TSS		42.62		MODRES	35.50	CL		58.4	Z7M0G7W		P	
UKR	UKR063300	38.20	31.74	48.22	2.29	0.96	177.78	R13TSS		41.01		MODRES	35.50	CR		58.9	Z7M0G7W		P	
USA	GUM63100	122.00	144.50	13.10	0.60	0.60	0.00	R13TSS		48.88		MODRES	35.50	CL		58.3	Z7M0G7W		P	
USA	MRA39200	121.80	145.90	16.90	1.20	0.60	76.00	R13TSS		45.87		MODRES	35.50	CR		58.4	Z7M0G7W		P	
USA	PLM33200	170.00	-161.40	7.00	0.60	0.60	0.00	R13TSS		48.88		MODRES	35.50	CL		57.4	Z7M0G7W		P	
USA	USAA-100	170.00	-170.51	-12.72				CB, TSS, USAA		48.88		MODRES	35.50	CL		56.1	Z7M0G7W		P	
USA	WAK33400	140.00	166.50	19.20	0.60	0.60	0.00	R13TSS		48.88		MODRES	35.50	CR		58.6	Z7M0G7W		P	
UZB	UZB07100	33.80	63.80	41.21	2.56	0.89	159.91	R13TSS		40.84		MODRES	35.50	CR		58.8	Z7M0G7W		P	
VTN	VTA32500	107.00	106.84	14.21	3.43	1.76	109.43	R13TSS		36.65		MODRES	35.50	CR		58.4	Z7M0G7W		P	
VUT	VUT12800	140.00	168.00	-16.40	1.52	0.68	87.00	R13TSS		44.30		MODRES	35.50	CL		57.8	Z7M0G7W		P	
YEM	YEM-100	11.00	48.05	14.64				CB, TSS, YEMA		47.63		MODRES	35.50	CL		54.9	Z7M0G7W		P	
ZMB	ZMB31400	-0.80	27.50	-13.10	2.38	1.48	39.00	R13TSS		38.98		MODRES	35.50	CR		58.4	Z7M0G7W		P	
ZWE	ZWE131500	-0.80	29.60	-18.80	1.46	1.36	37.00	R13TSS		41.47		MODRES	35.50	CR		59.2	Z7M0G7W		P	5,7

COLUMN HEADINGS IN TABLE 6B

- Col. 1 *Nominal orbital position*, in degrees and hundredths of a degree from the Greenwich meridian (negative values indicate longitudes which are west of the Greenwich meridian; positive values indicate longitudes which are east of the Greenwich meridian).
- Col. 2 *Notifying administration symbol*.
- Col. 3 *Beam identification* (Column 2, normally, contains the symbol designating the administration or the geographical area taken from Table B1 of the Preface to the International Frequency Information Circular (BR IFIC), followed by the symbol designating the service area).
- Col. 4 *Polarization* (CL – circular left, CR – circular right).
- Col. 5 *Channel number/Indication of minimum equivalent protection margin (EPM) for a given assignment derived from the set of values for all test points belonging to the given beam* (dB).

TABLE 6B  
Minimum equivalent protection margin of assignments in the Regions 1 and 3 Plan (sorted by orbital position)

1	2	3	4	Channel number																																																		
				Minimum EPM																																																		
				1	2	3	4	5	6	7	8	9	10	11	12	13	14	15	16	17	18	19	20	21	22	23	24	25	26	27	28	29	30	31	32	33	34	35	36	37	38	39	40											
-178.00	FJL	FH9300	CR	6.1	6.1	6.1	6.1	6.1	6.1	6.1	6.1	6.1	6.1	6.1	6.1	6.1	6.1	6.1	6.1	6.1	6.1	6.1	6.1	6.1	6.1	6.1	6.1	6.1	6.1	6.1	6.1	6.1	6.1	6.1	6.1	6.1	6.1	6.1	6.1	6.1	6.1	6.1												
-178.00	SNO	SNO06700	CR	1.6	1.6	1.6	1.6	1.6	1.6	1.6	1.6	1.6	1.6	1.6	1.6	1.6	1.6	1.6	1.6	1.6	1.6	1.6	1.6	1.6	1.6	1.6	1.6	1.6	1.6	1.6	1.6	1.6	1.6	1.6	1.6	1.6	1.6	1.6	1.6	1.6	1.6	1.6	1.6	1.6										
-160.00	F	OCF0100	CL	99.9	99.9	99.9	99.9	99.9	99.9	99.9	99.9	99.9	99.9	99.9	99.9	99.9	99.9	99.9	99.9	99.9	99.9	99.9	99.9	99.9	99.9	99.9	99.9	99.9	99.9	99.9	99.9	99.9	99.9	99.9	99.9	99.9	99.9	99.9	99.9	99.9	99.9	99.9	99.9	99.9										
-37.20	GNB	GNB5200	CL	4.6	1.9	1.9	1.9	1.9	1.9	1.9	1.9	1.9	1.9	1.9	1.9	1.9	1.9	1.9	1.9	1.9	1.9	1.9	1.9	1.9	1.9	1.9	1.9	1.9	1.9	1.9	1.9	1.9	1.9	1.9	1.9	1.9	1.9	1.9	1.9	1.9	1.9	1.9	1.9	1.9	1.9									
-37.20	RL	RL2100	CL	2.6	0.6	0.6	0.6	0.6	0.6	0.6	0.6	0.6	0.6	0.6	0.6	0.6	0.6	0.6	0.6	0.6	0.6	0.6	0.6	0.6	0.6	0.6	0.6	0.6	0.6	0.6	0.6	0.6	0.6	0.6	0.6	0.6	0.6	0.6	0.6	0.6	0.6	0.6	0.6	0.6										
-37.20	NGR	NGR11500	CL	6.8	6.8	6.8	6.8	6.8	6.8	6.8	6.8	6.8	6.8	6.8	6.8	6.8	6.8	6.8	6.8	6.8	6.8	6.8	6.8	6.8	6.8	6.8	6.8	6.8	6.8	6.8	6.8	6.8	6.8	6.8	6.8	6.8	6.8	6.8	6.8	6.8	6.8	6.8	6.8	6.8	6.8									
-37.00	AND	AND34100	CL	0.3	0.3	0.3	0.3	0.3	0.3	0.3	0.3	0.3	0.3	0.3	0.3	0.3	0.3	0.3	0.3	0.3	0.3	0.3	0.3	0.3	0.3	0.3	0.3	0.3	0.3	0.3	0.3	0.3	0.3	0.3	0.3	0.3	0.3	0.3	0.3	0.3	0.3	0.3	0.3	0.3	0.3									
-37.00	GUI	GUI16200	GR	0.9	0.9	0.9	0.9	0.9	0.9	0.9	0.9	0.9	0.9	0.9	0.9	0.9	0.9	0.9	0.9	0.9	0.9	0.9	0.9	0.9	0.9	0.9	0.9	0.9	0.9	0.9	0.9	0.9	0.9	0.9	0.9	0.9	0.9	0.9	0.9	0.9	0.9	0.9	0.9	0.9	0.9	0.9								
-37.00	POB	POB_100	GR	2.4	1.1	1.1	1.1	1.1	1.1	1.1	1.1	1.1	1.1	1.1	1.1	1.1	1.1	1.1	1.1	1.1	1.1	1.1	1.1	1.1	1.1	1.1	1.1	1.1	1.1	1.1	1.1	1.1	1.1	1.1	1.1	1.1	1.1	1.1	1.1	1.1	1.1	1.1	1.1	1.1	1.1	1.1								
-36.80	MTN	MTN_100	CR																																																			
-36.80	SMR	SMR31100	CR	4.4	3.2	3.2	3.1	3.1	3.1	3.1	3.1	3.1	3.1	3.1	3.1	3.1	3.1	3.1	3.1	3.1	3.1	3.1	3.1	3.1	3.1	3.1	3.1	3.1	3.1	3.1	3.1	3.1	3.1	3.1	3.1	3.1	3.1	3.1	3.1	3.1	3.1	3.1	3.1	3.1	3.1	3.1								
-33.50	CPV	CPV30100	CL	9.5	9.5	9.5	9.5	9.5	9.5	9.5	9.5	9.5	9.5	9.5	9.5	9.5	9.5	9.5	9.5	9.5	9.5	9.5	9.5	9.5	9.5	9.5	9.5	9.5	9.5	9.5	9.5	9.5	9.5	9.5	9.5	9.5	9.5	9.5	9.5	9.5	9.5	9.5	9.5	9.5	9.5	9.5								
-33.50	DNK	DNK0800R	CR																																																			
-33.50	DNK	DNK0610R	CR																																																			
-33.50	G	G_02700	GR	-0.1	0.1	-0.1	-0.1	-0.1	-0.1	-0.1	-0.1	-0.1	-0.1	-0.1	-0.1	-0.1	-0.1	-0.1	-0.1	-0.1	-0.1	-0.1	-0.1	-0.1	-0.1	-0.1	-0.1	-0.1	-0.1	-0.1	-0.1	-0.1	-0.1	-0.1	-0.1	-0.1	-0.1	-0.1	-0.1	-0.1	-0.1	-0.1	-0.1	-0.1	-0.1	-0.1								
-33.50	ISL	ISL04600	CL																																																			
-33.50	ISL	ISL05000	CR																																																			
-33.50	LBR	LBR24400	GR	3.3	0.4	0.4	0.4	0.4	0.4	0.4	0.4	0.4	0.4	0.4	0.4	0.4	0.4	0.4	0.4	0.4	0.4	0.4	0.4	0.4	0.4	0.4	0.4	0.4	0.4	0.4	0.4	0.4	0.4	0.4	0.4	0.4	0.4	0.4	0.4	0.4	0.4	0.4	0.4	0.4	0.4	0.4	0.4							
-33.50	SRL	SRL25900	GR																																																			
-30.00	BFA	BFA10700	CL																																																			
-30.00	E	E_100	CL																																																			
-30.00	E	HSP3301	CL																																																			
-30.00	E	HSP3302	CL																																																			
-30.00	E	HSP4270	CL																																																			
-30.00	GNB	GNB30400	CL																																																			
-30.00	TGO	TGO2800	GR	7.9	7.5	7.5	7.5	7.5	7.5	7.5	7.5	7.5	7.5	7.5	7.5	7.5	7.5	7.5	7.5	7.5	7.5	7.5	7.5	7.5	7.5	7.5	7.5	7.5	7.5	7.5	7.5	7.5	7.5	7.5	7.5	7.5	7.5	7.5	7.5	7.5	7.5	7.5	7.5	7.5	7.5	7.5	7.5	7.5						
-25.20	DNK	DNK_100	CL	-0.9	-1.5	-1.5	-1.5	-1.5	-1.5	-1.5	-1.5	-1.5	-1.5	-1.5	-1.5	-1.5	-1.5	-1.5	-1.5	-1.5	-1.5	-1.5	-1.5	-1.5	-1.5	-1.5	-1.5	-1.5	-1.5	-1.5	-1.5	-1.5	-1.5	-1.5	-1.5	-1.5	-1.5	-1.5	-1.5	-1.5	-1.5	-1.5	-1.5	-1.5	-1.5	-1.5	-1.5	-1.5	-1.5	-1.5				
-25.20	MRC	MRC20800	CL	0.1	-0.4	-0.4	-0.4	-0.4	-0.4	-0.4	-0.4	-0.4	-0.4	-0.4	-0.4	-0.4	-0.4	-0.4	-0.4	-0.4	-0.4	-0.4	-0.4	-0.4	-0.4	-0.4	-0.4	-0.4	-0.4	-0.4	-0.4	-0.4	-0.4	-0.4	-0.4	-0.4	-0.4	-0.4	-0.4	-0.4	-0.4	-0.4	-0.4	-0.4	-0.4	-0.4	-0.4	-0.4	-0.4	-0.4				
-25.20	TUN	TUN1500	CR																																																			
-25.20	TUN	TUN2700	CR																																																			
-25.00	GHA	GHA10800	CR																																																			
-24.80	AGL	AGL2600	CL	4.6	3.6	3.6	3.6	3.6	3.6	3.6	3.6	3.6	3.6	3.6	3.6	3.6	3.6	3.6	3.6	3.6	3.6	3.6	3.6	3.6	3.6	3.6	3.6	3.6	3.6	3.6	3.6	3.6	3.6	3.6	3.6	3.6	3.6	3.6	3.6	3.6	3.6	3.6	3.6	3.6	3.6	3.6	3.6	3.6	3.6					





		5																																						
		Channel number																																						
1	2	3	4	5	6	7	8	9	10	11	12	13	14	15	16	17	18	19	20	21	22	23	24	25	26	27	28	29	30	31	32	33	34	35	36	37	38	39	40	
Orbital Position	Admin. symbol	Beam Identification	Polarization type	Minimum EPM																																				
-7.00	SFP	SFP24100	GR	6.1	5.6	5.6	5.6	5.6	5.6	5.6	5.6	5.6	5.6	5.6	5.6	5.6	5.6	5.6	4.9																					
-4.00	ISR	ISR1000	GR																		3.1	3.0	3.1	3.0	3.1	3.0	3.1	3.0	3.1	3.0	3.1	3.0	3.1	3.0	3.1	3.0	3.1	5.7		
-1.20	BUL	BUL02000	CL																		1.0	-0.4	1.6	-0.4	1.6	-0.4	1.6	-0.4	1.6	-0.4	1.6	-0.4	1.6	-0.4	1.6	-0.4	1.6	-0.3		
-1.20	CVA	CVA98300	GR	2.2	0.5	0.9	0.9	0.9	0.9	0.9	0.9	0.9	0.9	0.9	0.9	0.9	0.9	0.9																						
-1.20	CVA	CVA96500	GR																																					
-1.20	CYP	CYP96800	GR	1.4	0.0	0.5	0.5	0.5	0.5	0.5	2.2	2.2	2.2	2.2	2.2	2.2	2.2	1.5																						
-1.00	JRC	JRC10500	CL	-0.4	0.6	-0.1	0.8	-0.1	0.9	-0.1	0.9	-0.1	0.9	-0.1	0.9	-0.1	0.9	-0.3	1.0																					
-1.00	MOZ	MOZ97000	CL	2.8	3.8	2.8	3.8	2.8	3.8	2.8	3.8	2.8	3.8	2.8	3.8	2.8	3.8	2.8	3.6																					
-0.80	BOT	BOT29700	CL																																					
-0.80	KEN	KEN24900	CL																																					
-0.80	NOR	NOR2000	CL	4.4	2.0	-0.7	-0.7	-0.7	-0.7	-0.7	-0.6	-0.6	-0.6	-0.6	-0.6	-0.6	-0.6	1.1																						
-0.80	NOR	NOR2100	CL																																					
-0.80	ZMB	ZMB5400	GR																																					
-0.80	ZWE	ZWE3500	GR	5.5	2.6	2.6	2.6	2.6	2.6	2.6	2.6	2.6	2.6	2.6	2.6	2.6	2.6	2.6																						
4.80	AFS	AFS92100	CL																																					
4.80	LSO	LSO9500	GR	3.9	2.9	2.9	2.9	2.9	2.9	3.1	3.1	3.1	3.1	3.1	3.1	3.1	2.9																							
4.80	MNI	MNI92600	GR	3.2	3.8	3.3	3.9	3.3	3.9	3.9	3.9	3.9	3.9	3.9	3.9	3.9	3.8	3.4																						
4.80	SWZ	SWZ1300	CL	4.5	3.2	3.2	3.2	3.2	3.2	3.4	3.4	3.4	3.4	3.4	3.4	3.4	3.2																							
5.00	S	S_13800	CL																																					
5.00	S	S_13800	CL																																					
9.00	I	I_10200	GR																																					
11.00	BDI	BDI27000	CL																																					
11.00	JOR	JOR2400	CL	-1.0	-0.8	-0.7	-0.7	-0.7	-0.7	-0.7	-0.7	-0.7	-0.7	-0.7	-0.7	-0.8	0.0																							
11.00	KWT	KWT13300	GR																																					
11.00	LEB	LEB27900	GR	0.9	-0.6	-0.1	-0.1	-0.1	-0.1	-0.1	-0.1	-0.1	-0.1	-0.1	-0.1	-0.1	-0.6																							
11.00	RW	RW91000	CL	10.2	10.2	10.2	10.2	10.2	10.2	10.2	10.2	10.2	10.2	10.2	10.2	10.2	10.2	10.2																						
11.00	SYR	SYR23900	CL																																					
11.00	SYR	SYR33900	CL																																					
11.00	TZA	TZA2900	GR																																					
11.00	YEM	YEM_100	CL	2.1	-0.3	-0.3	-0.3	-0.3	-0.3	-0.3	-0.3	-0.3	-0.3	-0.3	-0.3	-0.3	-0.3																							
16.80	DAJ	DAJ09900	CL	8.2	8.2	8.1	8.1	8.1	8.1	8.1	8.1	8.1	8.1	8.1	8.1	8.1	8.1	6.7																						
17.00	ARS	ARS_100	CL																																					
17.00	ARS	ARS4000	CL																																					
17.00	ARS	ARS4000	CL																																					
17.00	TCD	TCD14300	GR	9.8	8.8	8.8	8.8	8.8	8.8	8.8	8.8	8.8	8.8	8.8	8.8	8.8	8.8	8.8																						
17.00	UGA	UGA95100	CL																																					

\*\* See Note 1 of § 11.2.









ARTICLE 12 (REV.WRC-19)

**Relationship to Resolution 507 (Rev.WRC-19)**

12.1 The provisions and associated Plans for the broadcasting-satellite service in Regions 1 and 3 and in Region 2, of this Appendix, shall be regarded as including a world agreement and associated Plans for Regions 1, 2 and 3 in accordance with *resolves* 1 of Resolution **507 (Rev.WRC-19)**, which requires the stations in the broadcasting-satellite service to be established and operated in accordance with such agreements and associated Plans.

ARTICLE 13

**Interference**

13.1 The Member States of the Union shall endeavour to agree on the action required to reduce harmful interference which might be caused by the application of these provisions and the associated Plans.

ARTICLE 14

**Period of validity of the provisions and associated Plans**

14.1 For Regions 1 and 3, the provisions and associated Plan have been prepared in order to meet the requirements of the broadcasting-satellite service in the bands concerned for a period of at least fifteen years from 1 January 1979.

14.2 For Region 2, the provisions and associated Plan have been prepared in order to meet the requirements of the broadcasting-satellite service in the bands concerned for a period extending until at least 1 January 1994.

14.3 In any event, the provisions and associated Plans shall remain in force until their revision by a competent radiocommunication conference convened in accordance with the relevant provisions of the Constitution and Convention in force.

## ANNEX 1 (REV.WRC-19)

**Limits for determining whether a service of an administration is affected by a proposed modification to the Region 2 Plan or by a proposed new or modified assignment in the Regions 1 and 3 List or when it is necessary under this Appendix to seek the agreement of any other administration<sup>25</sup>**

(See Article 4)

**1 Limits for the interference into frequency assignments in conformity with the Regions 1 and 3 Plan or with the Regions 1 and 3 List or into new or modified assignments in the Regions 1 and 3 List**

Under assumed free-space propagation conditions, the power flux-density of a proposed new or modified assignment in the List shall not exceed the value of  $-103.6 \text{ dB(W/(m}^2 \cdot 27 \text{ MHz))}$ .

With respect to § 4.1.1 *a*) or *b*) of Article 4, an administration in Region 1 or 3 is considered by the Bureau as being affected if the minimum orbital spacing between the wanted and interfering space stations, under worst-case station-keeping conditions, is less than  $9^\circ$ .

However, an administration in Region 1 or 3 is considered as not being affected if either of the following two conditions is met:

- a)* under assumed free-space propagation conditions, the power flux-density at any test point within the service area associated with any of its frequency assignments in the Plan or in the List or for which the procedure of Article 4 has been initiated, does not exceed the following values: (WRC-15)

$$-147 \text{ dB(W/(m}^2 \cdot 27 \text{ MHz))} \quad \text{for } 0^\circ \leq \theta < 0.23^\circ$$

$$-135.7 + 17.74 \log \theta \text{ dB(W/(m}^2 \cdot 27 \text{ MHz))} \quad \text{for } 0.23^\circ \leq \theta < 2.0^\circ$$

$$-136.7 + 1.66 \theta^2 \text{ dB(W/(m}^2 \cdot 27 \text{ MHz))} \quad \text{for } 2.0^\circ \leq \theta < 3.59^\circ$$

$$-129.2 + 25 \log \theta \text{ dB(W/(m}^2 \cdot 27 \text{ MHz))} \quad \text{for } 3.59^\circ \leq \theta < 9^\circ$$

where  $\theta$  is the minimum geocentric orbital separation in degrees between the wanted and interfering space stations, taking into account the respective East-West station-keeping accuracies;

---

<sup>25</sup> With respect to this Annex, except for Section 2, the limits relate to the power flux-density which would be obtained assuming free-space propagation conditions.

With respect to Section 2 of this Annex, the limit specified relates to the overall equivalent protection margin calculated in accordance with § 2.2.4 of Annex 5.

<sup>26</sup> (SUP - WRC-15)



b) the effect of the proposed new or modified assignments in the List is that the equivalent downlink protection margin<sup>27</sup> corresponding to a test point of its assignment in the Regions 1 and 3 Plan or List, or for which the procedure of Article 4 has been initiated, including cumulative effect of any previous modification to the List or any previous agreement, does not fall more than 0.45 dB below 0 dB or, if already negative, more than 0.45 dB below the value resulting from:

- the Regions 1 and 3 Plan and List as established by WRC-2000; *or*
- a proposed new or modified assignment to the List in accordance with this Appendix; *or*
- a new entry in the Regions 1 and 3 List as a result of successful application of Article 4 procedures.

NOTE – In performing the calculation, the effect at the receiver input of all the co-channel and adjacent-channel signals is expressed in terms of one equivalent co-channel interfering signal. This value is usually expressed in decibels. (WRC-03)

## 2 Limits to the change in the overall equivalent protection margin for frequency assignments in conformity with the Region 2 Plan

With respect to § 4.2.3 c) of Article 4, an administration in Region 2 is considered as being affected if the overall equivalent protection margin<sup>28</sup> corresponding to a test point of its entry in the Region 2 Plan, including the cumulative effect of any previous modification to that Plan or any previous agreement, falls more than 0.25 dB below 0 dB, or, if already negative, more than 0.25 dB below the value resulting from:

- the Region 2 Plan as established by the 1983 Conference; *or*
- a modification of the assignment in accordance with this Appendix; *or*
- a new entry in the Region 2 Plan under Article 4; *or*
- any agreement reached in accordance with this Appendix. (WRC-03)

## 3 Limits to the change in the power flux-density to protect the broadcasting-satellite service in Regions 1 and 2 in the band 12.2-12.5 GHz and in Region 3 in the band 12.5-12.7 GHz

With respect to § 4.1.1 c) of Article 4, an administration in Region 2 is considered as being affected if the proposed new or modified assignment in the Regions 1 and 3 List would result in exceeding the following power flux-density values, at any test point in the service area of its overlapping frequency assignments:

-147 dB(W/(m <sup>2</sup> · 27 MHz))	for 0°	≤ θ < 0.23°
-135.7 + 17.74 log θ dB(W/(m <sup>2</sup> · 27 MHz))	for 0.23°	≤ θ < 1.8°
-134.0 + 0.89 θ <sup>2</sup> dB(W/(m <sup>2</sup> · 27 MHz))	for 1.8°	≤ θ < 5.0°

<sup>27</sup> For the definition of the equivalent protection margin, see § 3.4 of Annex 5.

<sup>28</sup> For the definition of the overall equivalent protection margin, see § 1.11 of Annex 5.

$$\begin{aligned} -129.2 + 25 \log \theta \quad \text{dB(W/(m}^2 \cdot 27 \text{ MHz))} & \quad \text{for } 5.0^\circ \leq \theta < 10.57^\circ \\ -103.6 \quad \text{dB(W/(m}^2 \cdot 27 \text{ MHz))} & \quad \text{for } 10.57^\circ \leq \theta \end{aligned}$$

where  $\theta$  is the minimum geocentric orbital separation in degrees between the wanted and interfering space stations, taking into account the respective East-West station-keeping accuracies.

With respect to § 4.2.3 *a*), 4.2.3 *b*) or 4.2.3 *f*) of Article 4, as appropriate, an administration in Region 1 or 3 is considered as being affected if the proposed modification to the Region 2 Plan would result in exceeding the following power flux-density values, at any test point in the service area of its overlapping frequency assignments:

$$\begin{aligned} -147 \quad \text{dB(W/(m}^2 \cdot 27 \text{ MHz))} & \quad \text{for } 0^\circ \leq \theta < 0.23^\circ \\ -135.7 + 17.74 \log \theta \quad \text{dB(W/(m}^2 \cdot 27 \text{ MHz))} & \quad \text{for } 0.23^\circ \leq \theta < 2.0^\circ \\ -136.7 + 1.66 \theta^2 \quad \text{dB(W/(m}^2 \cdot 27 \text{ MHz))} & \quad \text{for } 2.0^\circ \leq \theta < 3.59^\circ \\ -129.2 + 25 \log \theta \quad \text{dB(W/(m}^2 \cdot 27 \text{ MHz))} & \quad \text{for } 3.59^\circ \leq \theta < 10.57^\circ \\ -103.6 \quad \text{dB(W/(m}^2 \cdot 27 \text{ MHz))} & \quad \text{for } 10.57^\circ \leq \theta \end{aligned}$$

where  $\theta$  is the minimum geocentric orbital separation in degrees between the wanted and interfering space stations, taking into account the respective East-West station-keeping accuracies. (WRC-03)

#### 4 Limits to the power flux-density to protect the terrestrial services of other administrations<sup>29, 30, 31</sup>

With respect to § 4.1.1 *d*) of Article 4, an administration in Region 1, 2 or 3 is considered as being affected if the consequence of the proposed modified assignment in the Regions 1 and 3 List is to increase the power flux-density arriving on any part of the territory of that administration by more than 0.25 dB over that resulting from that frequency assignment in the Plan or List for Regions 1 and 3 as established by WRC-2000. The same administration is considered as not being affected if the value of the power flux-density anywhere in its territory does not exceed the limits expressed below.

With respect to § 4.2.3 *d*) of Article 4, an administration in Region 1, 2 or 3 is considered as being affected if the consequence of the proposed modification to an existing assignment in the Region 2 Plan is to increase the power flux-density arriving on any part of the territory of that administration by more than 0.25 dB over that resulting from that frequency assignment in the Region 2 Plan at the time of entry into force of the Final Acts of the 1985 Conference. The same administration is considered as not being affected if the value of the power flux-density anywhere in its territory does not exceed the limits expressed below.

<sup>29</sup> See § 3.18 of Annex 5.

<sup>30</sup> In the band 12.5-12.7 GHz in Region 1, these limits are applicable only to the territory of administrations mentioned in Nos. 5.494 and 5.496.

<sup>31</sup> See Resolution 34 (Rev.WRC-19). (WRC-19)

With respect to § 4.1.1 *d*) or § 4.2.3 *d*) of Article 4, an administration in Region 1, 2 or 3 is considered as being affected if the proposed new assignment in the Regions 1 and 3 List, or if the proposed new frequency assignment in the Region 2 Plan, would result in exceeding a power flux-density, for any angle of arrival, at any point on its territory, of:

$$\begin{aligned} -148 \text{ dB(W/(m}^2 \cdot 4 \text{ kHz))} & \quad \text{for } 0^\circ \leq \theta \leq 5^\circ \\ -148 + 0.5 (\theta - 5) \text{ dB(W/(m}^2 \cdot 4 \text{ kHz))} & \quad \text{for } 5^\circ < \theta \leq 25^\circ \\ -138 \text{ dB(W/(m}^2 \cdot 4 \text{ kHz))} & \quad \text{for } 25^\circ < \theta \leq 90^\circ \end{aligned}$$

where  $\theta$  represents the angle of arrival. (WRC-19)

5 (Not used.)

**6 Limits to the change in the power flux-density of assignments in the Regions 1 and 3 Plan or List to protect the fixed-satellite service (space-to-Earth) in the frequency band 11.7-12.2 GHz<sup>32</sup> in Region 2 or in the frequency band 12.2-12.5 GHz in Region 3, and of assignments in the Region 2 Plan to protect the fixed-satellite service (space-to-Earth) in the frequency band 12.5-12.7 GHz in Region 1 and in the frequency band 12.2-12.7 GHz in Region 3**

With respect to § 4.1.1 *e*) of Article 4, an administration is considered as being affected if the proposed new or modified assignment in the Regions 1 and 3 List would result in an increase in the power flux-density over any portion of the service area of its overlapping frequency assignments in the fixed-satellite service in Region 2 or Region 3 by more than 0.25 dB above that resulting from the frequency assignments in the Plan or List for Regions 1 and 3 as established by WRC-2000.

With respect to § 4.2.3 *e*), an administration is considered as being affected if the proposed modification to the Region 2 Plan would result in an increase in the power flux-density over any portion of the service area of its overlapping frequency assignments in the fixed-satellite service in Region 1 or 3 by more than 0.25 dB above that resulting from the frequency assignments in the Region 2 Plan at the time of entry into force of the Final Acts of the 1985 Conference.

With respect to § 4.1.1 *e*) or 4.2.3 *e*) of Article 4, with the exception of cases covered by Note 1 below, an administration is considered as not being affected if the proposed new or modified assignment in the Regions 1 and 3 List, or if a proposed modification to the Region 2 Plan, gives a power flux-density anywhere over any portion of the service area of its overlapping frequency assignments in the fixed-satellite service in Region 1, 2 or 3 of less than or equal to:

$$\begin{aligned} -186.5 \text{ dB(W/(m}^2 \cdot 40 \text{ kHz))} & \quad \text{for } 0^\circ \leq \theta < 0.054^\circ \\ -164.0 + 17.74 \log \theta \text{ dB(W/(m}^2 \cdot 40 \text{ kHz))} & \quad \text{for } 0.054^\circ \leq \theta < 2.0^\circ \\ -165.0 + 1.66 \theta^2 \text{ dB(W/(m}^2 \cdot 40 \text{ kHz))} & \quad \text{for } 2.0^\circ \leq \theta < 3.59^\circ \end{aligned}$$

---

<sup>32</sup> Including assignments operating under No. 5.485.

$$-157.5 + 25 \log \theta \quad \text{dB}(W/(m^2 \cdot 40 \text{ kHz})) \quad \text{for } 3.59^\circ \leq \theta < 10.57^\circ$$

$$-131.9 \quad \text{dB}(W/(m^2 \cdot 40 \text{ kHz})) \quad \text{for } 10.57^\circ \leq \theta$$

where  $\theta$  is the minimum geocentric orbital separation in degrees between the wanted and interfering space stations, taking into account the respective East-West station-keeping accuracies.

NOTE 1 – With respect to § 4.1.1 e) of Article 4, an administration in Region 3 is considered as not being affected if the proposed new or modified assignment in the Regions 1 and 3 List in the orbital arc 105° E-129° E gives a power flux-density anywhere over any portion of the territory of the notifying administration within the service area of its overlapping frequency assignments in the fixed-satellite service in the orbital arc 110° E-124° E of less than or equal to:

$$-186.5 \quad \text{dB}(W/(m^2 \cdot 40 \text{ kHz})) \quad \text{for } 0^\circ \leq \theta < 0.054^\circ$$

$$-164.0 + 17.74 \log \theta \quad \text{dB}(W/(m^2 \cdot 40 \text{ kHz})) \quad \text{for } 0.054^\circ \leq \theta < 1.8^\circ$$

$$-162.3 + 0.89 \theta^2 \quad \text{dB}(W/(m^2 \cdot 40 \text{ kHz})) \quad \text{for } 1.8^\circ \leq \theta < 5.0^\circ$$

$$-157.5 + 25 \log \theta \quad \text{dB}(W/(m^2 \cdot 40 \text{ kHz})) \quad \text{for } 5.0^\circ \leq \theta < 10.57^\circ$$

$$-131.9 \quad \text{dB}(W/(m^2 \cdot 40 \text{ kHz})) \quad \text{for } 10.57^\circ \leq \theta$$

where  $\theta$  is the minimum geocentric orbital separation in degrees between the wanted and interfering space stations, taking into account the respective East-West station-keeping accuracies.

The above set of formulas is only applied to networks:

- for which Appendix 4 information for coordination had been received by the Bureau prior to 30 March 2002; *and*
- which had been brought into use prior to 30 March 2002 and for which the date of bringing into use had been confirmed to the Bureau; *and*
- for which the complete due diligence information, in accordance with Annex 2 to Resolution 49 (Rev.WRC-19), had been received by the Bureau prior to 30 March 2002. (WRC-19)

## 7 Limits to the change in equivalent noise temperature to protect the fixed-satellite service (Earth-to-space) in Region 1 from modifications to the Region 2 Plan in the band 12.5-12.7 GHz

With respect to § 4.2.3 e) of Article 4, an administration is considered as being affected if the proposed modification to the Region 2 Plan would result in:

- the value of  $\Delta T/T$  of its overlapping frequency assignments in the fixed-satellite service in Region 1 resulting from the proposed modification is greater than the value of  $\Delta T/T$  resulting from the assignment in the Region 2 Plan as of the date of entry into force of the Final Acts of the 1985 Conference; *and*
- the value of  $\Delta T/T$  of its overlapping frequency assignments in the fixed-satellite service in Region 1 resulting from the proposed modification exceeds 6%,

using the method of Appendix 8 (Case II). (WRC-07)

## ANNEX 2 (REV.WRC-03)

**Basic characteristics to be furnished in notices relating to  
space stations in the broadcasting-satellite service**

These data items are listed in Appendix 4.

## ANNEX 3 (WRC-03)

**Method for determining the limiting interfering power flux-density at  
the edge of a broadcasting-satellite service area in the frequency bands  
11.7-12.2 GHz (in Region 3), 11.7-12.5 GHz (in Region 1) and 12.2-12.7 GHz  
(in Region 2), and for calculating the power flux-density produced in these  
bands by a terrestrial station, or by a transmitting earth station in the  
fixed-satellite service in the band 12.5-12.7 GHz**

## 1 General

1.1 This Annex describes a method of calculating the interference potential from terrestrial transmitters or transmitting earth stations in the fixed-satellite service (FSS) to receiving earth stations in the broadcasting-satellite service (BSS).

1.2 The method is in two parts:

- a) the calculation of the maximum permissible interfering power flux-density at the edge of the BSS area concerned;
- b) the calculation of the likely power flux-density produced at any point on the edge of the service area by the terrestrial transmitter or transmitting earth stations in the FSS of another administration.

1.3 The interference potential of the terrestrial transmitters or the transmitting earth stations in the FSS must be considered case by case; the power flux-density produced by each terrestrial transmitter or each transmitting earth station  $F_p$  is compared to the limiting power flux-density  $F$  at any point on the edge of the service area of a broadcasting-satellite station of another administration. If, for a given transmitter, the value of the power flux-density produced  $F_p$  is lower than the value of the limiting power flux-density  $F$  at any point on the edge of the service area, the interference caused to the BSS by this transmitter is considered to be lower than the permissible value and no coordination is required between administrations before the terrestrial service station or the transmitting earth station is brought into use. Where this is not the case, coordination and more precise calculations derived from a mutually agreed basis are necessary.

Section 2 calculates the limit of power flux-density  $F$  at the edge of the service area.

Section 3 calculates the power flux-density produced by a terrestrial station or a transmitting earth station,  $F_p$ .

1.4 It is emphasized that, should the calculation described in this Annex indicate that the maximum permissible power flux-density is exceeded, it does not necessarily preclude the introduction of the terrestrial or the FSS since the calculations are necessarily based on worst-case assumptions for:

- a) the nature of the terrain of the interference path;
- b) the off-beam discrimination on the broadcasting-satellite receiving installations;
- c) the necessary protection ratios for the BSS;
- d) the type of reception in the BSS, i.e., assuming individual reception, this being more critical than community reception for the angles of elevation concerned;
- e) the value of power flux-density to be protected in the BSS;
- f) the propagation conditions between the terrestrial station or the transmitting earth station in the FSS operating in the opposite direction of transmission, and the BSS area.

## 2 Limit of power flux-density

### 2.1 General

The limiting power flux-density not to be exceeded at the edge of the service area in order to protect the BSS of an administration is given by the formula:

$$F = F_0 - R + D + P \quad (1)$$

where:

- F*: the maximum permissible interfering power flux-density (dB(W/m<sup>2</sup>)) within the necessary bandwidth of the broadcasting-satellite;
- F*<sub>0</sub>: the wanted power flux-density (dB(W/m<sup>2</sup>)) at the edge of the service area;
- R*: the protection ratio (dB) between the wanted and interfering signals;
- D*: angular antenna discrimination (dB) provided by the radiation pattern of the broadcasting-satellite receiver antenna;
- P*: polarization discrimination (dB) between the wanted and interfering signals.

### 2.2 Wanted power flux-density (*F*<sub>0</sub>)

The value of *F*<sub>0</sub> is equal to:

For the Regions 1 and 3 Plan and List, Region 2 Plan and Article 4 submissions under § 4.1.3 and 4.2.6:

- a) -108 dB(W/(m<sup>2</sup> · 27 MHz)) for service areas in Regions 1 and 3, and
- b) -115 dB(W/(m<sup>2</sup> · 24 MHz)), as well as in dB(W/(m<sup>2</sup> · 27 MHz)) with respect to the cases mentioned in the footnote to § 3.8 of Annex 5 concerning necessary bandwidths in Region 2.

For the analogue BSS assignments in the Region 2 Plan:

-107 dB(W/(m<sup>2</sup> · 24 MHz)), as well as in dB(W/(m<sup>2</sup> · 27 MHz)) with respect to the cases mentioned in the footnote to § 3.8 of Annex 5 concerning necessary bandwidths in Region 2.

**2.3 Protection ratio (R)**

2.3.1 For digital BSS assignments, the single entry protection ratio is equal to 30 dB.

2.3.2 For the analogue BSS assignments in the Region 2 Plan and for notified BSS assignments in Regions 1 and 3 Plan and List which are in conformity with the Plans and List of Appendix 30 and which have been brought into use and for which the date of bringing into use has been confirmed to the Bureau before 9 June 2003, the single entry protection ratio against all types of terrestrial transmissions, with the exception of amplitude-modulation multichannel television systems, is 35 dB for carrier frequency differences between the wanted and interfering signals of up to ±10 MHz, decreasing linearly from 35 dB to 0 dB for carrier frequency differences between 10 MHz and 35 MHz, and is 0 dB for frequency differences in excess of 35 MHz (see Fig. 1). For amplitude-modulation multichannel television systems which produce high peaks of power flux-density spread over a wide range of their necessary bandwidth, the protection ratio *R* is 35 dB and is independent of the carrier frequency difference.

2.3.3 The carrier frequency difference should be determined by reference to the frequency assignments in the broadcasting-satellite Plan or, in the case of assignments not contained within a plan, by reference to the characteristics of the proposed or operational system.

2.3.4 A signal from a terrestrial station or a transmitting earth station in the FSS should be considered only if its necessary bandwidth overlaps the necessary bandwidth of the BSS assignment.

FIGURE 1  
**Protection ratio (*R*) (dB) for a broadcasting-satellite signal  
 against a single entry of interference from a terrestrial service  
 (except for AM multichannel TV system)**

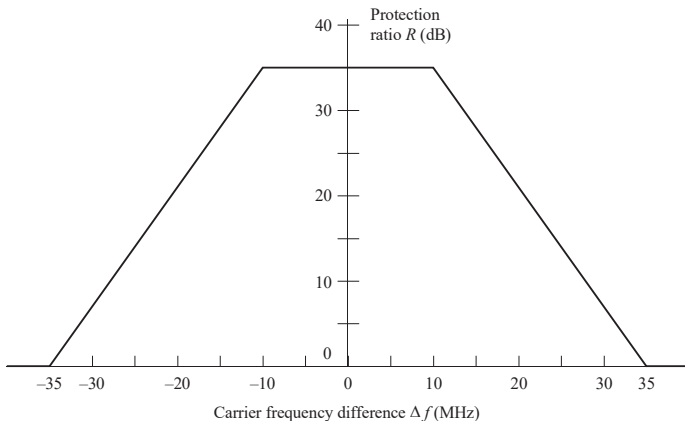

AP30A3-01

**2.4 Angular antenna discrimination (*D*)**

**2.4.1 For all Regions (digital)**

The value of *D* to be assumed in equation (1) is derived from the following equations, which are based on Recommendation ITU-R BO.1213 (also found in Annex 5):

$$\begin{aligned}
 D &= 0.0025((d/\lambda) \varphi)^2 && \text{dB} && \text{for } 0^\circ \leq \varphi < \varphi_m \\
 D &= G_{max} - (29 - 25 \log(\varphi_r)) && \text{dB} && \text{for } \varphi_m \leq \varphi < \varphi_r \\
 D &= G_{max} - (29 - 25 \log(\varphi)) && \text{dB} && \text{for } \varphi_r \leq \varphi \leq 14.45^\circ \\
 D &= G_{max} && \text{dB} && \text{for } \varphi > 14.45^\circ
 \end{aligned}
 \tag{2}$$

where:

- $\varphi$ : elevation angle (degrees) for the proposed or operational broadcasting-satellite system for the BSS area concerned
- $\varphi_m$ :  $(\lambda/d)((G_{max} - G_1)/(0.0025))^{0.5}$  (degrees)
- $G_1$ :  $29 - 25 \log(\varphi_r)$  (dB)
- $\varphi_r$ :  $95(\lambda/d)$  (degrees)
- $G_{max}$ : maximum gain of the antenna (dBi)
- $d$ : diameter of the antenna (m)
- $\lambda$ : the wavelength (m).

NOTE 1 – If more than one value of  $\varphi$  is specified for a particular service area, the appropriate value of  $\varphi$  should be used for each section of the edge of the service area under consideration.

For Regions 1 and 3,  $G_{max} = 35.5$  dBi corresponding to a 0.6 m diameter antenna at 11.7 GHz and 65% efficiency. For Region 2,  $G_{max} = 33.3$  dBi corresponding to a 0.45 m diameter antenna at 12.2 GHz and 65% efficiency. For a graphical depiction of this antenna discrimination see Fig. 2.

FIGURE 2  
Discrimination *D* of a broadcasting-satellite receiving antenna as a function of elevation angle

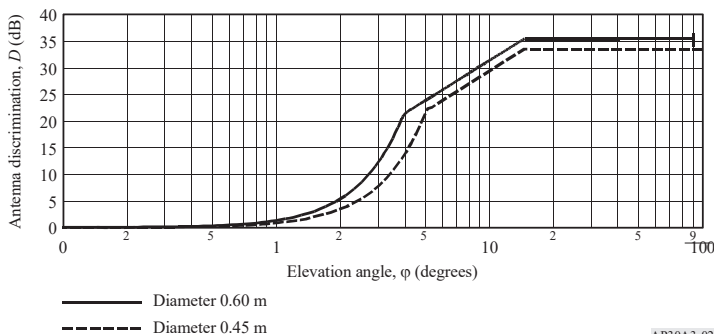

AP30A3-02



**2.4.2 For the analogue BSS assignments in the Region 2 Plan**

The discrimination  $D$  should be derived from the expression (3) below where  $\varphi$  is the elevation angle for the proposed or operational broadcasting-satellite system for the BSS area concerned.

NOTE 1 – If more than one value of  $\varphi$  is specified for a particular service area, the appropriate value of  $\varphi$  should be used for each section of the edge of the service area under consideration.

$$\begin{aligned}
 D &= 0 && \text{dB} && \text{for } 0^\circ \leq \varphi \leq 0.43^\circ \\
 D &= 4.15 \varphi^2 && \text{dB} && \text{for } 0.43^\circ < \varphi \leq 1.92^\circ \\
 D &= 8.24 + 25 \log \varphi && \text{dB} && \text{for } 1.92^\circ < \varphi \leq 25^\circ \\
 D &= 43.2 && \text{dB} && \text{for } \varphi > 25^\circ
 \end{aligned}
 \tag{3}$$

NOTE 2 – For the graphical determination of  $D$  see Fig. 3. The unit for  $\varphi$  is degrees.

**2.5 Polarization discrimination ( $P$ )**

The value of  $P$  is equal to:

- a) 3 dB when the interfering service uses linear polarization and the BSS uses circular polarization or vice versa;
- b) 0 dB when the interfering service and the BSS both use circular or both use linear polarization.

FIGURE 3  
Discrimination  $D$  of broadcasting-satellite receiving antenna  
as a function of elevation angle

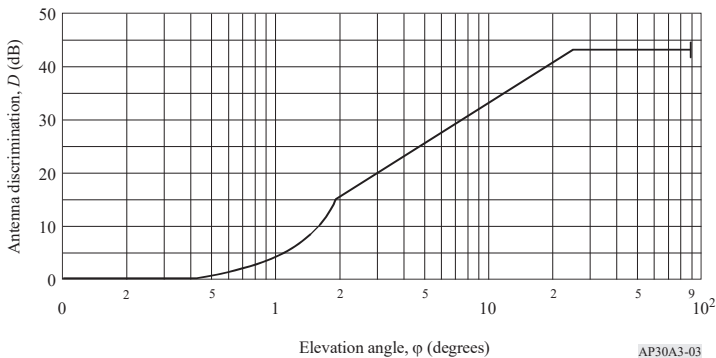

**3 Power flux-density produced by a terrestrial station or a transmitting earth station ( $F_p$ )**

The power flux-density  $F_p$  (dB(W/m<sup>2</sup>)) produced at any point on the edge of the service area by the terrestrial station or the transmitting earth station is determined from the following formula:

$$F_p = E - A + 10 \log (4\pi/\lambda^2)
 \tag{4}$$

where:

$E$ : equivalent isotropically radiated power (dBW) of the terrestrial station or the transmitting earth station in the direction of the point concerned on the edge of the service area

$A$ : total path loss (dB)

$\lambda$ : wavelength (m).

### 3.1 Evaluation of path loss $A$ for a terrestrial station or a transmitting earth station at the edge of the service area of the broadcasting satellite

The following propagation model is to be used for determining the minimum path loss between the interfering terrestrial transmitter or transmitting earth station and the edge of the BSS service area.

### 3.2 Propagation model

#### 3.2.1 Distance limits

##### 3.2.1.1 Minimum distance limit

The minimum coordination distance is given as:

$$d_{min}(f) = 100 + \frac{(\beta_p - f)}{2} \quad (5)$$

where:

$f$ : frequency (GHz)

$\beta_p$ : radiometeorological parameter, which reflects the relative incidence of clear-sky anomalous propagation conditions.

The value of  $\beta_p$  is latitude dependent. The latitude to be used in determining the correct value for  $\beta_p$  is given by:

$$\zeta_r = \begin{cases} |\zeta| - 1.8 & \text{for } |\zeta| > 1.8^\circ \\ 0 & \text{for } |\zeta| \leq 1.8^\circ \end{cases} \quad (6)$$

where  $\zeta$  is the earth station latitude (degrees).

$\beta_p$  is then determined using:

$$\beta_p = \begin{cases} 10^{(1.67 - 0.015\zeta_r)} & \text{for } \zeta_r \leq 70^\circ \\ 4.17 & \text{for } \zeta_r > 70^\circ \end{cases} \quad (7)$$

##### 3.2.1.2 Maximum distance limit

The maximum distance,  $d_{max}$ , for paths comprising a single climatic zone must not exceed the value for that climatic zone given in the Table below. For mixed paths comprising multiple zones the overall maximum distance must not exceed the value in the Table below corresponding to the climatic zone in the mixed path having the largest value (e.g. for a mixed path comprising Zones A1 and A2,  $d_{max}$  is 500 km).

Climatic Zone <sup>1</sup>	Maximum distance, $d_{max}^2$
A1	500
A2	375
B	900
C	1 200

<sup>1</sup> For the definition see Appendix 7, § 1.5.1 and 1.5.3.2.

<sup>2</sup> As computed in § 2 of Appendix 7.

### 3.2.2 Ducting model

#### 3.2.2.1 Distance-independent part of the loss (dB) for ducting

For BSS earth stations, no additional protection due to the earth station horizon elevation angle can be assumed, i.e.  $A_h$ , the total terrain shielding attenuation, is 0 dB. However, if the detailed information for the transmitting station is known, including any site-shielding-based mitigation techniques that are used, all these factors need to be included in the determination of the coordination distance.

Reduction in attenuation arising from direct coupling into over-sea ducts (dB):

$$A_c = \frac{-6}{1 + d_c} \tag{8}$$

where  $d_c$  (km) is the distance from a land-based transmitting station to the coast in the direction being considered.  $d_c$  is zero in other circumstances.

Distance-independent part of the loss (dB) for ducting:

$$A_1 = 122.43 + 16.5 \log f + A_c \tag{9}$$

#### 3.2.2.2 Distance-dependent part of the loss (dB) for ducting

a) The specific attenuation (dB/km) due to dry air is given as:

$$\gamma_0 = \left( 7.19 \times 10^{-3} + \frac{6.09}{f^2 + 0.227} + \frac{4.81}{(f - 57)^2 + 1.50} \right) f^2 \times 10^{-3} \tag{10}$$

b) The specific attenuation due to water vapour is given as a function of  $\rho$ , the water vapour density in units of  $\text{g/m}^3$ , by the following equation:

$$\gamma_w(\rho) = \left( 0.050 + 0.0021\rho + \frac{3.6}{(f - 22.2)^2 + 8.5} \right) f^2 \rho \times 10^{-4} \tag{11}$$

c) The specific attenuation (dB/km) due to water vapour for the ducting propagation model using a water vapour density of  $7.5 \text{ g/m}^3$  for paths over land in Zones A1 and A2 is given as:

$$\gamma_{wdl} = \gamma_w(7.5) \tag{12}$$

d) The specific attenuation (dB/km) due to water vapour for the ducting propagation model using a water vapour density of  $10.0 \text{ g/m}^3$  for paths over sea in Zones B and C is given as:

$$\gamma_{wds} = \gamma_w (10.0) \quad (13)$$

Note that the value of  $10.0 \text{ g/m}^3$  is used for both Zones B and C in view of the lack of data on the variability of water vapour density on a global basis, particularly the minimum values.

e) Specific attenuation due to gaseous absorption (dB/km):

$$\gamma_g = \gamma_0 + \gamma_{wdl} \left( \frac{d_t}{d_i} \right) + \gamma_{wds} \left( 1 - \frac{d_t}{d_i} \right) \quad (14)$$

where:

$d_t$  (km): aggregate land distance (Zone A1 + Zone A2) along the path;

$d_i$  (km): path length considered, which lies within the range between a minimum calculation distance and a maximum calculation distance.

f) Values for zone-dependent parameters:

$$\tau = 1 - \exp\left(-\left(4.12 \times 10^{-4} (d_{lm})^{2.41}\right)\right) \quad (15)$$

where:

$d_{lm}$  (km): longest continuous inland distance (Zone A2) along the path considered.

$$\mu_1 = \left( \frac{-d_{lm}}{10^{16 - 6.6\tau} + \left(10^{-(0.496 + 0.354\tau)}\right)^5} \right)^{0.2} \quad (16)$$

where:

$d_{lm}$  (km): longest continuous land (i.e. inland + coastal) distance (Zone A1 + Zone A2) along the path considered.

$\mu_1$  is limited to  $\mu_1 \leq 1$ .

$$\sigma = -0.6 - 8.5 \times 10^{-9} d_i^{3.1} \tau \quad (17)$$

$\sigma$  is limited to  $\sigma \geq -3.4$ .

$$\mu_2 = \left( 2.48 \times 10^{-4} d_i^2 \right)^\sigma \quad (18)$$

$\mu_2$  is limited to  $\mu_2 \leq 1$ .

$$\mu_4 = \begin{cases} 10^{(-0.935 + 0.0176 \zeta_r) \log \mu_1} & \text{for } \zeta_r \leq 70^\circ \\ 10^{0.3 \log \mu_1} & \text{for } \zeta_r > 70^\circ \end{cases} \quad (19)$$

g) Path-dependent incidence of ducting,  $\beta$ , and the related parameter,  $\Gamma_1$ , that are used to calculate time dependency of the path loss are given as:

$$\beta = \beta_e \cdot \mu_1 \cdot \mu_2 \cdot \mu_4 \quad (20)$$

$$\Gamma_1 = \frac{1.076}{(2.0058 - \log \beta)^{1.012}} \exp\left(-\left(9.51 - 4.8 \log \beta + 0.198(\log \beta)^2\right) \times 10^{-6} d_i^{1.13}\right) \quad (21)$$

h) Distance-dependent part of the loss (dB) for ducting:

$$L_5(p) = (\gamma_d + \gamma_g) d_i + (1.2 + 3.7 \times 10^{-3} d_i) \log\left(\frac{p}{\beta}\right) + 12\left(\frac{p}{\beta}\right)^{\Gamma_1} + C_{2i} \quad (22)$$

where:

$p$ : the maximum percentage of time for which the permissible interference power may be exceeded;  $p = 0.3\%$

$\gamma_d$ : the frequency-dependent ducting specific attenuation (dB/km).

$$\gamma_d = 0.05 f^{1/3} \quad (23)$$

NOTE 1 – For coordination of terrestrial mobile transmitting stations, fixed stations and transmitting earth stations, the mitigation factor  $C_{2i}$  was set equal to zero.

i) Attenuation due to ducting:

$$A_{duct} = A_1 + L_5(p) \quad (24)$$

### 3.2.3 For the tropospheric scatter model

#### 3.2.3.1 Distance-independent part of the loss (dB) for tropospheric scatter

$$A_2 = 187.36 + 10\varepsilon_h + L_f - 0.15N_0 - 10.1\left(-\log\left(\frac{p}{50}\right)\right)^{0.7} \quad (25)$$

where:

$\varepsilon_h$ : earth station horizon elevation angle (degrees)

$N_0$ : path centre sea level surface refractivity given as:

$$N_0 = 330 + 62.6 e^{-\left(\frac{\zeta - 2}{32.7}\right)^2} \quad (26)$$

$L_f$ : the frequency-dependent part of the loss (dB), given as:

$$L_f = 25 \log(f) - 2.5\left(\log\left(\frac{f}{2}\right)\right)^2 \quad (27)$$

3.2.3.2 *Distance-dependent part of the loss (dB) for tropospheric scatter*

$$L_6(p) = 20 \log(d_i) + 5.73 \times 10^{-4} (112 - 15 \cos(2\zeta)) d_i + (\gamma_0 + \gamma_{wt}) d_i + C_{2i} \quad (28)$$

Total attenuation due to tropospheric scatter:

$$A_{trop} = A_2 + L_6(p) \quad (29)$$

3.2.3.3 *Minimum path loss*

The minimum path loss,  $A_{min}$ , between the site of the interfering transmitter and the edge of the BSS service area is given by:

$$A_{min} = \min(A_{duct}, A_{trop}) \quad (30)$$

ANNEX 4 (REV.WRC-19)

**Need for coordination of a transmitting space station in the fixed-satellite service or in the broadcasting-satellite service where this service is not subject to a Plan: in Region 2 (11.7-12.2 GHz) with respect to the Plan, the List or proposed new or modified assignments in the List for Regions 1 and 3; in Region 1 (12.5-12.7 GHz) and in Region 3 (12.2-12.7 GHz) with respect to the Plan or proposed modifications to the Plan in Region 2; in Region 3 (12.2-12.5 GHz) with respect to the Plan, List or proposed new or modified assignments in the List for Region 1**

(See Article 7)

With respect to § 7.1 and 7.2 of Article 7, coordination of a transmitting space station in the fixed-satellite service (FSS) (space-to-Earth) of Region 2 or Region 3 is required when, under assumed free-space propagation conditions, the power flux-density over any portion of the service area of the overlapping frequency assignments in the BSS of an administration in Region 1 or Region 3 exceeds the following values: (WRC-07)

-147 dB(W/(m <sup>2</sup> · 27 MHz))	for 0° ≤ θ < 0.23°
-135.7 + 17.74 log θ dB(W/(m <sup>2</sup> · 27 MHz))	for 0.23° ≤ θ < 2.0°
-136.7 + 1.66 θ <sup>2</sup> dB(W/(m <sup>2</sup> · 27 MHz))	for 2.0° ≤ θ < 3.59°
-129.2 + 25 log θ dB(W/(m <sup>2</sup> · 27 MHz))	for 3.59° ≤ θ < 10.57°
-103.6 dB(W/(m <sup>2</sup> · 27 MHz))	for 10.57° ≤ θ

where θ is the minimum geocentric orbital separation in degrees between the wanted and interfering space stations, taking into account the respective East-West station-keeping accuracies.

In the case of an administration in Region 3 that has notified and brought into use its BSS Plan assignments before 9 June 2003, and whose notified assignments have been recorded in the Master Register with a favourable finding and for which the date of bringing into use has been confirmed to the Bureau, with respect to § 7.2.1 a) of Article 7, the conditions contained above are replaced by the following conditions:

- under assumed free-space propagation conditions, the power flux-density at any test point within the service area of the overlapping frequency assignments in the Plan exceeds the following values: <sup>(WRC-19)</sup>

$-147 \text{ dB(W/(m}^2 \cdot 27 \text{ MHz))}$	for $0^\circ$	$\leq \theta < 0.23^\circ$
$-135.7 + 17.74 \log \theta \text{ dB(W/(m}^2 \cdot 27 \text{ MHz))}$	for $0.23^\circ$	$\leq \theta < 1.8^\circ$
$-134.0 + 0.89 \theta^2 \text{ dB(W/(m}^2 \cdot 27 \text{ MHz))}$	for $1.8^\circ$	$\leq \theta < 5.0^\circ$
$-129.2 + 25 \log \theta \text{ dB(W/(m}^2 \cdot 27 \text{ MHz))}$	for $5.0^\circ$	$\leq \theta < 10.57^\circ$
$-103.6 \text{ dB(W/(m}^2 \cdot 27 \text{ MHz))}$	for $10.57^\circ$	$\leq \theta$

where  $\theta$  is the minimum geocentric orbital separation in degrees between the wanted and interfering space stations, taking into account the respective East-West station-keeping accuracies.

With respect to § 7.1 and 7.2 of Article 7, coordination of a transmitting space station in the FSS (space-to-Earth) in Region 1 or 3 or BSS not subject to a Plan in Region 3 is required when, under assumed free-space propagation conditions, the power flux-density over any portion of the service area of the overlapping frequency assignments in the BSS of an administration in Region 2 exceeds the following values:

- |                                                                       |                   |                             |
|-----------------------------------------------------------------------|-------------------|-----------------------------|
| $-147 \text{ dB(W/(m}^2 \cdot 27 \text{ MHz))}$                       | for $0^\circ$     | $\leq \theta < 0.23^\circ$  |
| $-135.7 + 17.74 \log \theta \text{ dB(W/(m}^2 \cdot 27 \text{ MHz))}$ | for $0.23^\circ$  | $\leq \theta < 1.8^\circ$   |
| $-134.0 + 0.89 \theta^2 \text{ dB(W/(m}^2 \cdot 27 \text{ MHz))}$     | for $1.8^\circ$   | $\leq \theta < 5.0^\circ$   |
| $-129.2 + 25 \log \theta \text{ dB(W/(m}^2 \cdot 27 \text{ MHz))}$    | for $5.0^\circ$   | $\leq \theta < 10.57^\circ$ |
| $-103.6 \text{ dB(W/(m}^2 \cdot 27 \text{ MHz))}$                     | for $10.57^\circ$ | $\leq \theta$               |

where  $\theta$  is the minimum geocentric orbital separation in degrees between the wanted and interfering space stations, taking into account the respective East-West station-keeping accuracies.

---

<sup>33</sup> (SUP - WRC-15)

## ANNEX 5

**Technical data used in establishing the provisions and associated Plans  
and the Regions 1 and 3 List, which should be used  
for their application<sup>34</sup> (Rev.WRC-03)**

## **1 Definitions**

### **1.1 Downlink service area**

The area on the surface of the Earth in which the administration responsible for the service has the right to demand that the agreed protection conditions be provided.

NOTE – In the definition of service area, it is made clear that within the service area the agreed protection conditions can be demanded. This is the area where there should be at least the wanted power flux-density and protection against interference based on the agreed protection ratio for the agreed percentage of time.

### **1.2 Downlink coverage area**

The area on the surface of the Earth delineated by a contour of a constant given value of power flux-density which would permit the wanted quality of reception in the absence of interference.

NOTE 1 – In accordance with the provisions of No. 23.13, the coverage area must be the smallest area which encompasses the service area.

NOTE 2 – The coverage area, which will normally encompass the entire service area, will result from the intersection of the antenna beam (elliptical, circular, or shaped) with the surface of the Earth, and will be defined by a given value of power flux-density. For example, it would be the area delineated by the contour corresponding to the level specified in § 3.16 of this Annex. There will usually be an area outside the service area but within the coverage area in which the power flux-density will be at least equivalent to the minimum specified value; however, protection against interference will not be provided in this area.

NOTE 3 – If coverage is provided by a steerable beam, the contour delineating the coverage area will depend on the pointing capability of the beam and will not necessarily cover the entire service area.

### **1.3 Downlink beam area**

The area delineated by the intersection of the half-power beam of the satellite transmitting antenna with the surface of the Earth. The downlink beam area concept was generally used for planning purposes in conjunction with elliptical beams.

NOTE – The beam area is simply that area on the Earth's surface corresponding to the  $-3$  dB points on the satellite antenna radiation pattern. In many cases the beam area would almost coincide with the coverage area, the discrepancy being accounted for by the permanent difference in path lengths from the satellite throughout the beam area, and also by the permanent variations, if any, in propagation factors across the area. However, for a service area where the maximum dimension as seen from the satellite position is less than  $0.6^\circ$  in Regions 1 and 3, and less than  $0.8^\circ$  in Region 2 (the agreed minimum practicable satellite antenna half-power beamwidths), there could be a significant difference between the beam area and the coverage area.

---

<sup>34</sup> In revising this Annex at WRC-97 and at WRC-2000, no changes have been made to the technical data applicable to the Region 2 Plan. However, for all three Regions, it should be noted that some of the parameters of networks proposed as modifications to the Region 2 Plan and the Regions 1 and 3 List may differ from the technical data presented herein. (WRC-2000)



**1.4 Nominal orbital position**

The longitude of a position in the geostationary-satellite orbit associated with a frequency assignment to a space station in a space radiocommunication service. The position is given in degrees from the Greenwich meridian.

NOTE – Definitions in § 1.6 to 1.11 are applicable to Region 2. (WRC-2000)

**1.5 Adjacent channel**

The RF channel in the broadcasting-satellite service frequency Plan, or in the associated feeder-link frequency Plan, which is situated immediately higher or lower in frequency with respect to the reference channel.

**1.6 Second adjacent channel**

The RF channel in the broadcasting-satellite service frequency Plan, or in the associated feeder-link frequency Plan, which is situated immediately beyond either of the adjacent channels, with respect to the reference channel.

**1.7 Overall carrier-to-interference ratio**

The overall carrier-to-interference ratio is the ratio of the wanted carrier power to the sum of all interfering RF powers in a given channel including both feeder links and downlinks. The overall carrier-to-interference ratio due to interference from the given channel is calculated as the reciprocal of the sum of the reciprocals of the feeder-link carrier-to-interference ratio and the down-link carrier-to-interference ratio referred to the satellite receiver input and earth station receiver input, respectively<sup>35</sup>.

**1.8 Overall co-channel protection margin**

The overall co-channel protection margin in a given channel is the difference in decibels between the overall co-channel carrier-to-interference ratio and the co-channel protection ratio.

**1.9 Overall adjacent channel protection margin**

The overall adjacent channel protection margin is the difference in decibels between the overall adjacent channel carrier-to-interference ratio and the adjacent channel protection ratio.

**1.10 Overall second adjacent channel protection margin**

The overall second adjacent channel protection margin is the difference in decibels between the overall second adjacent channel carrier-to-interference ratio and the second adjacent channel protection ratio.

---

<sup>35</sup> There are a total of five overall carrier-to-interference ratios used in the analysis of the Plan for the broadcasting-satellite service in Region 2, namely, co-channel, upper and lower adjacent channels, and upper and lower second adjacent channels. In Regions 1 and 3, three ratios are normally used, namely, co-channel and upper and lower adjacent channels. However, see the footnote to the definition of  $M_4$  and  $M_5$  in § 1.11 of this Annex.

## 1.11 Overall equivalent protection margin<sup>36</sup>

The overall equivalent protection margin,  $M$ , is given in decibels by the expression:

$$M = -10 \log \left( \sum_{i=1}^5 10^{(-M_i/10)} \right)$$

where:

$M_1$ : overall co-channel protection margin (dB) (as defined in § 1.8);

$M_2, M_3$ : overall adjacent channel protection margins for the upper and lower adjacent channels, respectively (dB) (as defined in § 1.9);

$M_4, M_5$ : overall second adjacent channel protection margins for the upper and lower second adjacent channels, respectively (dB) (as defined in § 1.10)<sup>37</sup>.

The adjective “equivalent” indicates that the protection margins for all interference sources from the adjacent and second adjacent channels as well as co-channel interference sources have been included. (WRC-2000)

## 2 Radio propagation factors

*In Regions 1 and 3:*

2.1 The propagation loss on the space-to-Earth path (used for computing downlink e.i.r.p. and as a guide in choosing orbital locations during the development of the Plan) is equal to the free-space path loss plus the atmospheric absorption and the rain attenuation exceeded for 1% of the worst month. Values of this attenuation can be calculated as a function of angle of elevation for the rain-climatic zones shown in Figs. 1 and 2 from Recommendation ITU-R P.837-1 by applying the method described in Recommendation ITU-R P.618-5.

---

<sup>36</sup> For calculation of overall equivalent protection margin for Regions 1 and 3, as defined at WARC Orb-88, see alternative formula in § 1.12 to Annex 3 of Appendix 30A.

<sup>37</sup>  $M_4$  and  $M_5$  are applicable only for Region 2. (WRC-2000)

FIGURE 1  
Rain-climatic zones for Regions 1 and 3 between  
longitudes 45° W and 105° E

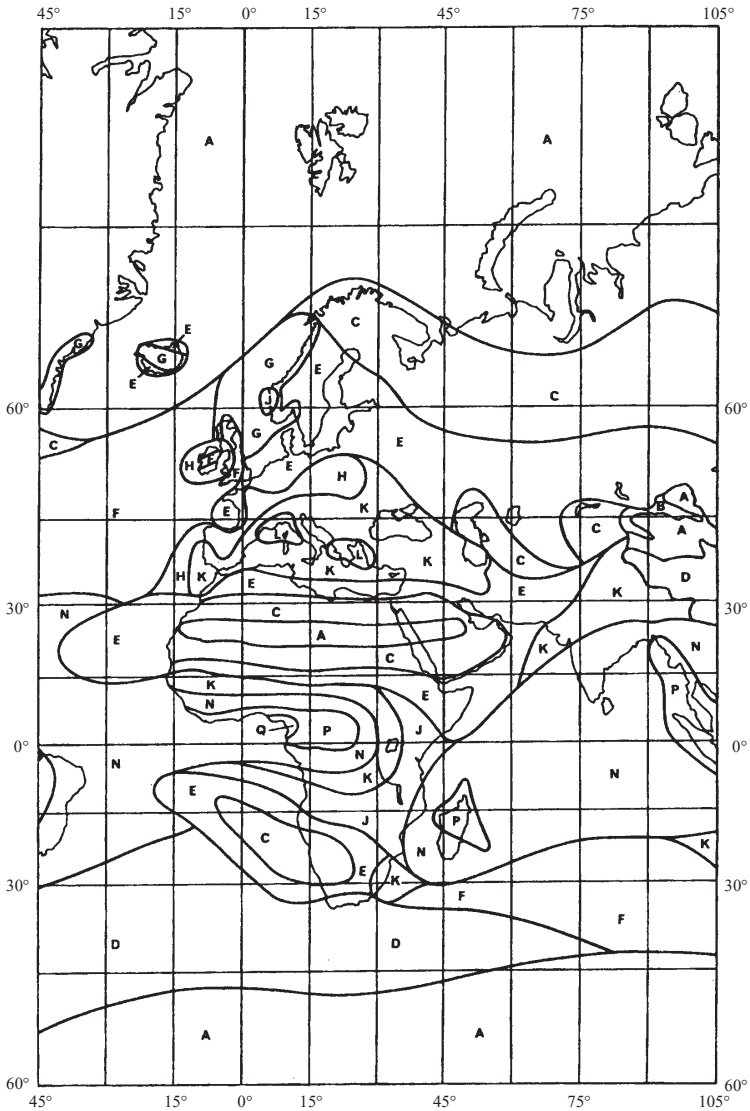

AP30A5-01

FIGURE 2  
 Rain-climatic zones for Regions 1 and 3 between  
 longitudes 60° E and 150° W

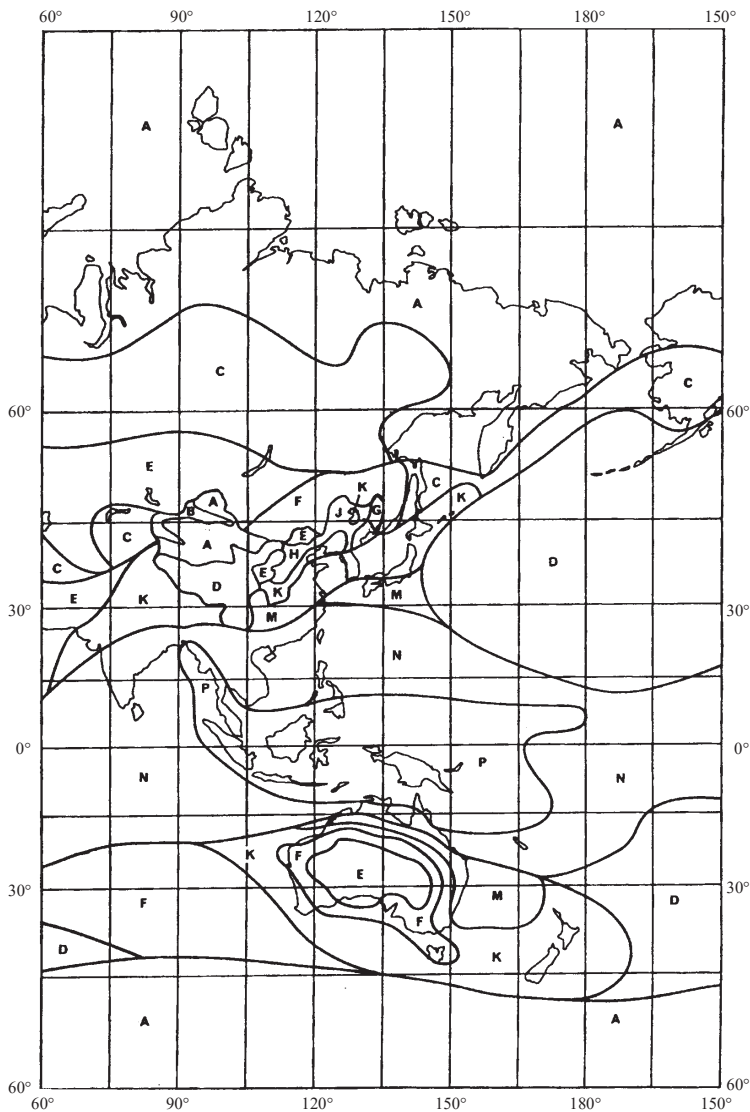

AP30A5-02

In Region 2:

2.2 The propagation loss on a space-Earth path is equal to the free-space path loss plus the atmospheric absorption loss plus the rain attenuation exceeded for 1% of the worst month.

**2.2.1 Atmospheric absorption**

The loss due to atmospheric absorption (i.e. clear-sky attenuation) is given by:

$$A_a = \frac{92.20}{\cos \theta} [0.017F_o + 0.002\rho F_w] \quad \text{dB} \quad \text{for } \theta < 5^\circ$$

where:

$$F_o = \left[ 24.88 \tan \theta + 0.339 \sqrt{1\,416.77 \tan^2 \theta + 5.51} \right]^{-1}$$

$$F_w = \left[ 40.81 \tan \theta + 0.339 \sqrt{3\,811.66 \tan^2 \theta + 5.51} \right]^{-1}$$

and:

$$A_a = \frac{0.042 + 0.003 \rho}{\sin \theta} \quad \text{dB} \quad \text{for } \theta \geq 5^\circ$$

where:

- θ: elevation angle (degrees),
- ρ: surface water vapour concentration (g/m<sup>3</sup>), being
  - ρ = 10 g/m<sup>3</sup> for rain climatic zones A to K and
  - ρ = 20 g/m<sup>3</sup> for rain climatic zones M to P (see Fig. 3).

**2.2.2 Rain attenuation**

The rain attenuation  $A_p$  of circularly polarized signals exceeded for 1% of the worst month at 12.5 GHz is given by:

$$A_p = 0.21 \gamma L r \quad \text{dB} \quad (31)$$

where:

$L$ : slant path length through rain

$$= \frac{2(h_R - h_0)}{\left\{ \sin^2 \theta + 2 \frac{h_R - h_0}{8\,500} \right\}^{1/2} + \sin \theta} \quad \text{km}$$

$r$ : rain path length reduction factor

$$= \frac{90}{90 + 4L \cos \theta}$$

$h_R$ : rain height (km)

$$= c \left\{ 5.1 - 2.15 \log \left( 1 + 10^{(\zeta - 27)/25} \right) \right\} \quad \text{km}$$

where:

$$c = 0.6 \quad \text{for} \quad |\zeta| \leq 20^\circ$$

$$c = 0.6 + 0.02 (|\zeta| - 20) \quad \text{for} \quad 20^\circ < |\zeta| \leq 40^\circ$$

$$c = 1.0 \quad \text{for} \quad |\zeta| > 40^\circ$$

$h_0$ : height (km) above mean sea level of the earth station;

$\zeta$ : earth station latitude (degrees);

$\theta$ : elevation angle (degrees);

$\gamma$ : specific rain attenuation =  $0.0202 R^{1.198}$  dB/km;

$R$ : rain intensity (mm/h) obtained from the table below for the rain climatic zones identified in Fig. 3.

(NOTE – The method is based on  $R$  exceeded for 0.01% of an average year.)

**Rainfall intensity ( $R$ ) for the rain climatic zones  
(exceeded for 0.01% of an average year) (see Fig. 3)**

Rain climatic zone	A	B	C	D	E	F	G	K	M	N	P
Rainfall intensity (mm/h)	8	12	15	19	22	28	30	42	63	95	145

Figure 4 presents plots of rain attenuation, as calculated using equation (31), of circularly polarized signals exceeded for 1% of the worst month at 12.5 GHz, as a function of earth station latitude and elevation angle for each of the rain climatic zones shown in Fig. 3.

### 2.2.3 Rain attenuation limit

In the analysis of the Plan for the broadcasting-satellite service in Region 2, a maximum downlink attenuation of 9 dB was agreed in order to limit the inhomogeneity of broadcasting-satellite power flux-density and to facilitate sharing during clear-sky conditions.

FIGURE 3  
Rain-climatic zones (Region 2)

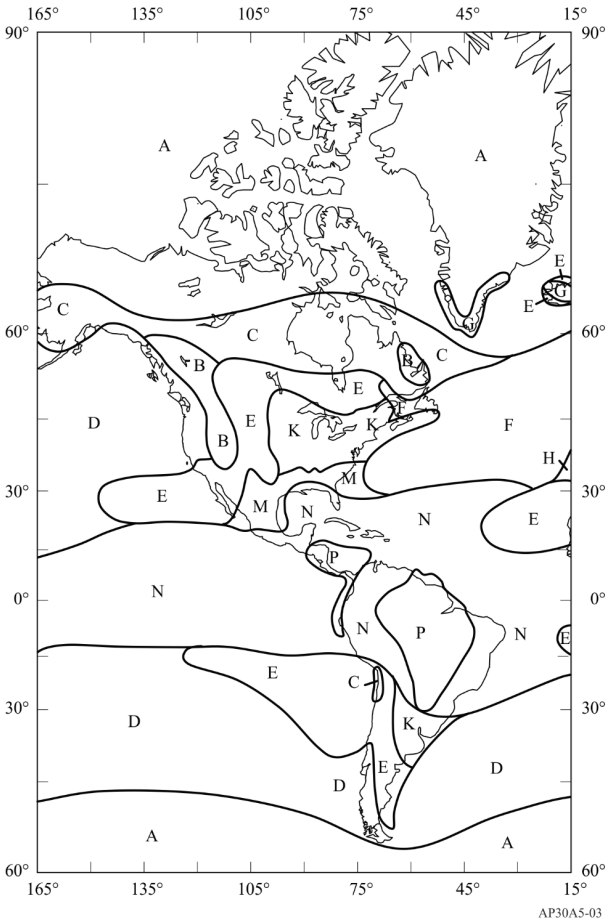

AP30A5-03

### 2.2.4 Procedure for calculating the carrier-to-interference ratio at a test point

The calculation of the down-link carrier-to-interference ratio (exceeded for 99% of the worst month) used to obtain the overall equivalent protection margin at a test point is the minimum value of the carrier-to-interference ratio obtained assuming:

- i) clear-sky conditions (i.e. including atmospheric absorption); or
- ii) rain-faded conditions corresponding to an attenuation value exceeded for 1% of the worst month.

### 2.3 Depolarization

Rain and ice can cause depolarization of radio frequency signals. The level of the co-polar component relative to the depolarized component is given by the cross-polarization discrimination (XPD) ratio. For circularly polarized emissions, the XPD ratio (dB) exceeded for 99% of the worst month is obtained from:

$$XPD = 30 \log f - 40 \log (\cos \theta) - 20 \log A_p \quad \text{for } 5^\circ \leq \theta \leq 60^\circ \quad (32)$$

where  $A_p$  (dB) is the co-polar rain attenuation exceeded for 1% of the worst month (calculated in § 2.2),  $f$  is the frequency in GHz and  $\theta$  is the elevation angle. For angles of  $\theta$  greater than  $60^\circ$ , use  $\theta = 60^\circ$  in equation (32).



FIGURE 4  
**Rain attenuation values exceeded for 1% of the worst month  
 (sea level) for Region 2 rain-climatic zones**

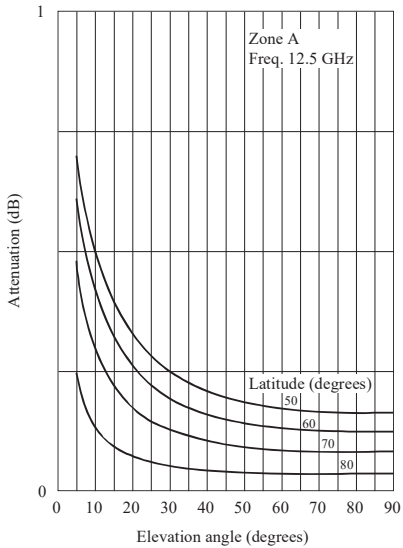

a) Rain-climatic zone A

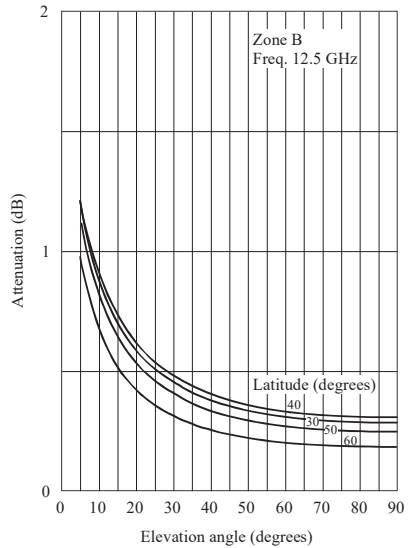

b) Rain-climatic zone B

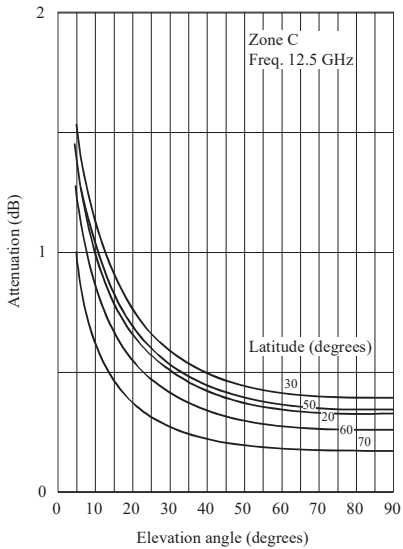

c) Rain-climatic zone C

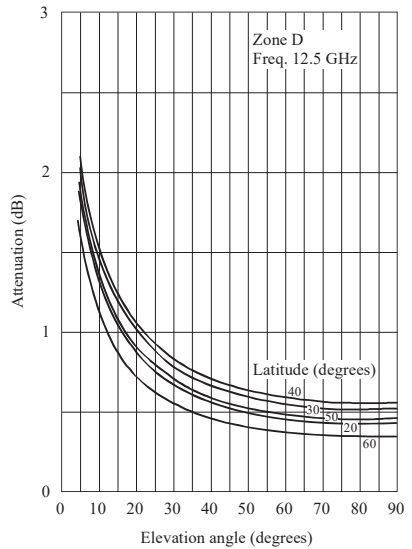

d) Rain-climatic zone D

AP30A5-04a

FIGURE 4 (continued)

Rain attenuation values exceeded for 1% of the worst month  
(sea level) for Region 2 rain-climatic zones

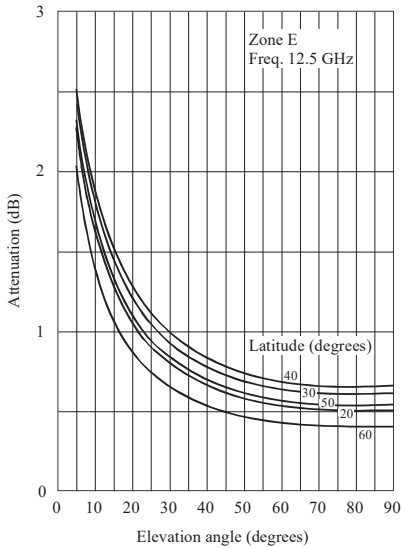

e) Rain-climatic zone E

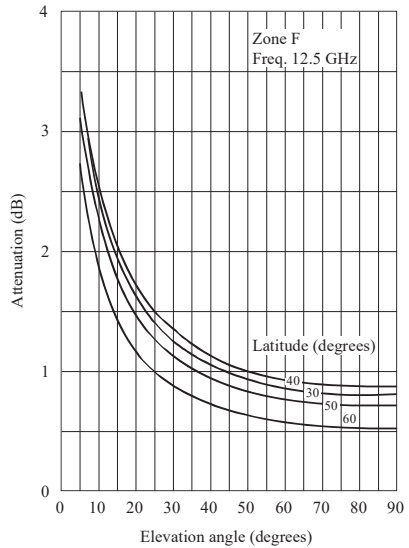

f) Rain-climatic zone F

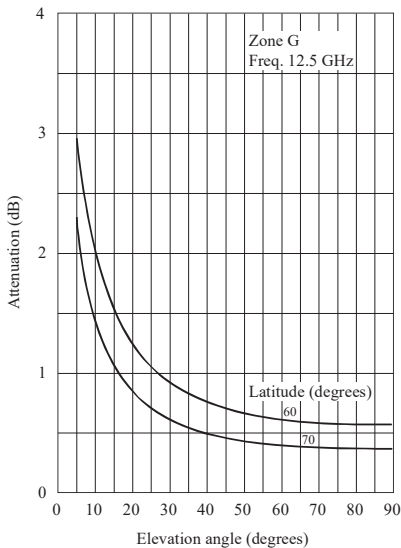

g) Rain-climatic zone G

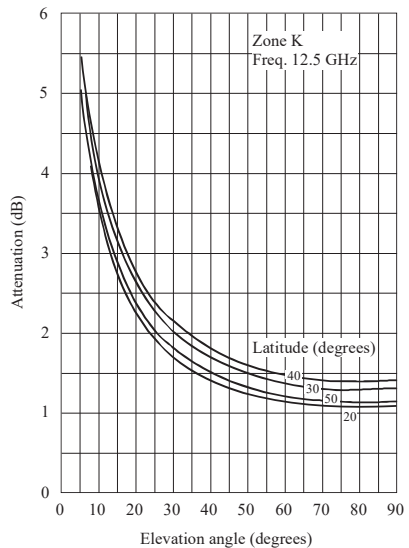

h) Rain-climatic zone K

AP30A5-04b

FIGURE 4 (continued)

Rain attenuation values exceeded for 1% of the worst month  
(sea level) for Region 2 rain-climatic zones

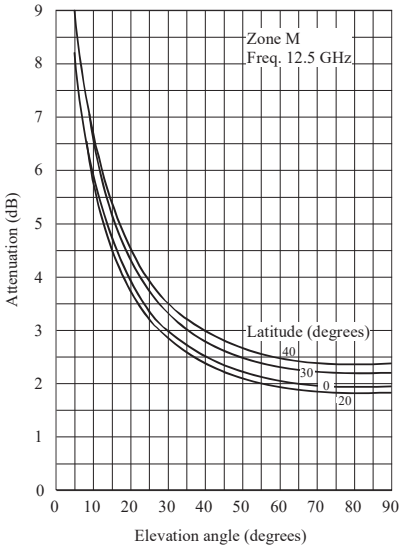

j) Rain-climatic zone M

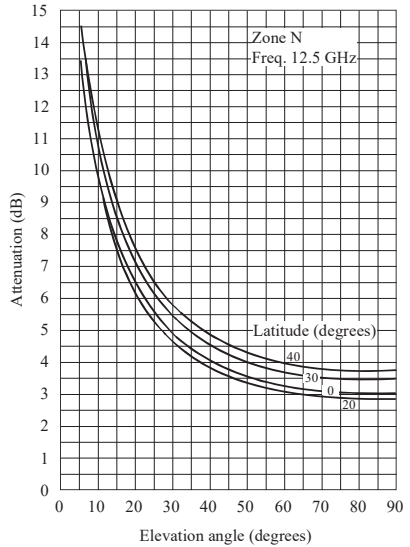

k) Rain-climatic zone N

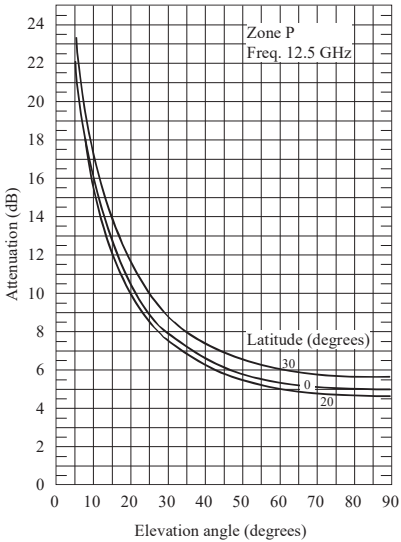

l) Rain-climatic zone P

AP30A5-04c

### 3 Basic technical characteristics

#### 3.1 Type of modulation

3.1.1 At WARC-77 and during revision of the Regions 1 and 3 Plan at WRC-97, planning of the broadcasting-satellite service was based on the use of a signal consisting of a video signal with an associated carrier, frequency-modulated by a sound signal, both frequency-modulating a carrier in the 12 GHz band, with a pre-emphasis characteristic in accordance with Fig. 5 (from Recommendation ITU-R F.405-1\*). The WRC-2000 Regions 1 and 3 Plan and the List are generally based on digital modulation of sound and television signals. (WRC-2000)

FIGURE 5  
Pre-emphasis characteristic for television on 525- and 625-line systems

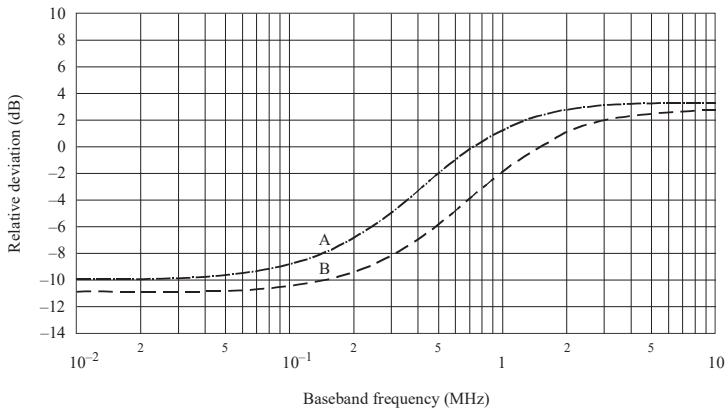

Curves A: 525-line system  
B: 625-line system

AP30A5-05

3.1.2 In Region 2, planning is based on the use of a frequency-modulated composite-coded colour television signal with two sound sub-carriers. However, in recognition of the need to provide for the use of new, enhanced television coding and modulation formats (e.g. time-compressed, multiplexed analogue video component signals and digitally-coded sound and data signals), values of the important technical characteristics have been chosen to take into consideration the implementation of these new formats within the provisions of the Plan.

\* Note by the Secretariat: This Recommendation was suppressed by the Radiocommunication Assembly (Geneva, 2003).

3.1.3 Nevertheless, other modulating signals having different characteristics (e.g. modulation with sound channels frequency-multiplexed within the bandwidth of a television channel, digital modulation of sound and television signals, or other pre-emphasis characteristics) are not precluded, provided that appropriate protection masks and calculation methods<sup>38</sup> are applied or if the use of such characteristics complies with the provisions of § 3.2 of Article 3.

### 3.2 Polarization

3.2.1 For the planning of the broadcasting-satellite service, circular polarization is generally used. However, for implementation of assignments in the Plan, linear polarization may also be used, subject to the successful application of the modification procedure of Article 4.

3.2.2 In Regions 1 and 3, the polarization of different beams intended to serve the same area should, if possible, be the same.

3.2.3 The terms “direct” and “indirect” used in the Plans to indicate the direction of rotation of circularly-polarized waves correspond to right-hand (clockwise) and left-hand (anti-clockwise) polarization respectively according to the following definitions:

*Direct polarization* (right-hand or clockwise polarization):

An elliptically or circularly-polarized electromagnetic wave, in which the electric field-intensity vector, observed in any *fixed plane*, normal to the direction of propagation, whilst looking in (i.e., not against) the direction of propagation, rotates *with time* in a *right-hand* or clockwise direction.

NOTE – For right-hand circularly-polarized plane waves, the ends of the electric vectors drawn from any points along a straight line normal to the plane of the wave front form, *at any instant*, a *left-hand* helix.

*Indirect polarization* (left-hand or anti-clockwise polarization):

An elliptically or circularly-polarized electromagnetic wave, in which the electric field-intensity vector, observed in any *fixed plane*, normal to the direction of propagation, whilst looking in (i.e., not against) the direction of propagation, rotates *with time* in a *left-hand* or anti-clockwise direction.

NOTE – For left-hand circularly-polarized plane waves, the ends of the electric vectors drawn from any points along a straight line normal to the plane of the wave front form, *at any instant*, a *right-hand* helix.

3.2.4 Linear polarization is defined in Recommendation ITU-R BO.1212. This Recommendation should be used when analysing linearly polarized signals.

### 3.3 Carrier-to-noise ratio

For the purpose of planning the broadcasting-satellite service, the carrier-to-noise ratio is equal to or exceeds 14 dB for 99% of the worst month.

---

<sup>38</sup> Protection masks for verifying that this provision is met are not yet fully defined in existing ITU-R Recommendations. Recommendations for interference between analogue and digital signals are still under development. In absence of criteria to evaluate interference, the Bureau will use the worst-case approach as adopted by the Radio Regulations Board.

In Regions 1 and 3, the reduction in quality in the down-link due to thermal noise in the feeder-link is taken as equivalent to a degradation in the down-link carrier-to-noise ratio not exceeding 0.5 dB for 99% of the worst month. In Region 2, as a guide for planning, the reduction in quality in the down-link due to thermal noise in the feeder link is taken as equivalent to a degradation in the down-link carrier-to-noise ratio of approximately 0.5 dB not exceeded for 99% of the worst month, but the feeder-link and down-link Plans are evaluated on the basis of the overall carrier-to-noise ratio of 14 dB for the combined down-link and feeder-link contributions.

**3.4 Protection ratio between television signals**

For developing the original 1977 broadcasting-satellite service Plan for Regions 1 and 3, the following protection ratios were used<sup>39, 40</sup>:

- 31 dB for co-channel signals;
- 15 dB for adjacent channel signals.

For revising this Plan at WRC-97, the following aggregate downlink protection ratios were specified in Recommendation ITU-R BO.1297 for the purpose of calculating downlink equivalent protection margins<sup>40, 41, 42</sup>:

- 24 dB for co-channel signals;
- 16 dB for adjacent channel signals.

---

<sup>39</sup> These protection ratio values were used for the assignments notified, which are in conformity with this Appendix, brought into use, and for which the date of bringing into use has been confirmed to the Bureau before 27 October 1997.

<sup>40</sup> The equivalent protection margin *M* is given in dB by the formula:

$$M = -10 \log (10^{-M_1/10} + 10^{-M_2/10} + 10^{-M_3/10})$$

where *M*<sub>1</sub> is the value (dB) of the protection margin for the same channel. This is defined in the following expression where the powers are evaluated at the receiver input:

$$\frac{\text{wanted power}}{\text{sum of the co-channel interfering powers}} \quad (\text{dB}) - \text{co-channel protection ratio (dB)}$$

*M*<sub>2</sub> and *M*<sub>3</sub> are the values (dB) of the upper and lower adjacent-channel protection margins respectively.

The definition of the adjacent-channel protection margin is similar to that for the co-channel case except that the adjacent-channel protection ratio and the sum of the interfering powers due to emissions in the adjacent channel are considered.

<sup>41</sup> These protection ratio values were used for the assignments notified, which are in conformity with this Appendix, brought into use, and for which the date of bringing into use has been confirmed to the Bureau between 27 October 1997 and 12 May 2000. (WRC-2000)

<sup>42</sup> These protection ratio values were used for protection of digital and analogue assignments from analogue emissions. (WRC-2000)

## AP30-120

In revising the Regions 1 and 3 Plan at WRC-97, the following aggregate overall protection ratio values were used for calculating the overall co-channel and adjacent-channel protection margins as defined in § 1.8 and 1.9:

- 23 dB for co-channel signals;
- 15 dB for adjacent channel signals.

It was also specified that for the revision of the Regions 1 and 3 Plan, no overall co-channel single entry  $C/I$  should be lower than 28 dB.

However, for the assignments notified, which are in conformity with this Appendix, brought into use, and for which the date of bringing into use has been confirmed to the Bureau before 27 October 1997, the overall equivalent protection margins were calculated using a co-channel overall protection ratio of 30 dB and lower and upper overall adjacent channel protection ratios of 14 dB<sup>43</sup>.

WRC-2000 adopted, for the protection of digital assignments from digital emissions, the following protection ratio values to be applied for calculation of downlink equivalent protection margins of the WRC-2000 Regions 1 and 3 Plan:

- 21 dB for co-channel signals;
- 16 dB for adjacent channel signals.

During planning at WRC-2000, these values were used for all assignments of the Regions 1 and 3 Plan and List except those for which WRC-2000 adopted different values used in the planning process<sup>44</sup>.

Revision of the Regions 1 and 3 Plan at WRC-97 and planning at WRC-2000 were generally based on a set of reference parameters such as the average e.i.r.p., the reference earth station receiving antenna, all test points placed within the  $-3$  dB contour, a bandwidth of 27 MHz and the predetermined value of  $C/N$ . The Regions 1 and 3 Plan as established by WRC-2000 is generally based on the use of digital modulation.

Protection masks and associated calculation methods for interference into broadcasting satellite systems involving digital emissions shall be in accordance with Recommendation ITU-R BO.1293-2 (Annexes 1 and 2<sup>45</sup>).

In Region 2, the following protection ratios have been adopted for the purpose of calculating the overall equivalent protection margin<sup>46</sup>:

- 28 dB for co-channel signals;
- 13.6 dB for adjacent-channel signals;
- $-9.9$  dB for second adjacent-channel signals.

---

<sup>43</sup> The overall protection margin calculation method used is based on the first formula in § 1.12 of Annex 3 to Appendix 30A.

<sup>44</sup> For analogue assignments, the protection ratios adopted by WRC-97 were used (24 dB co-channel and 16 dB adjacent channel). (WRC-2000)

<sup>45</sup> Annex 3 of this Recommendation may be applied only in compatibility analysis for bilateral coordination between administrations. (WRC-03)

<sup>46</sup> The definitions in § 1.7, 1.8, 1.9, 1.10 and 1.11 of this Annex apply to these calculations. (WRC-03)

In Region 2, as a guide for planning, the reduction in the overall  $C/I$  ratio due to co-channel interference in the feeder link is taken as equivalent to a degradation in the downlink co-channel  $C/I$  ratio of approximately 0.5 dB not exceeded for 99% of the worst month; however, the feeder-link and downlink Plans are evaluated on the basis of the overall equivalent protection margin, which includes the combined downlink and feeder-link contributions.

In Region 2, an overall equivalent protection margin of 0 dB, or greater, indicates that the individual protection ratios have been met for the co-channel, the adjacent channels and the second adjacent channels. (WRC-03)

**3.4.1 Adjacent channel protection ratio template for Region 2<sup>47</sup> (FMTV into FMTV)**

The protection ratios for adjacent channels are derived from the template given in Fig. 6. The template is symmetrical and is given in terms of absolute levels for the  $C/I$  ratios.

The template is obtained by joining the segment for adjacent channels to the horizontal extension of the co-channel protection ratio value. The adjacent channel protection ratio cannot be adjusted relative to the co-channel value.

FIGURE 6  
Protection ratio template (FMTV/FMTV), for planning  
of broadcasting-satellite systems in Region 2

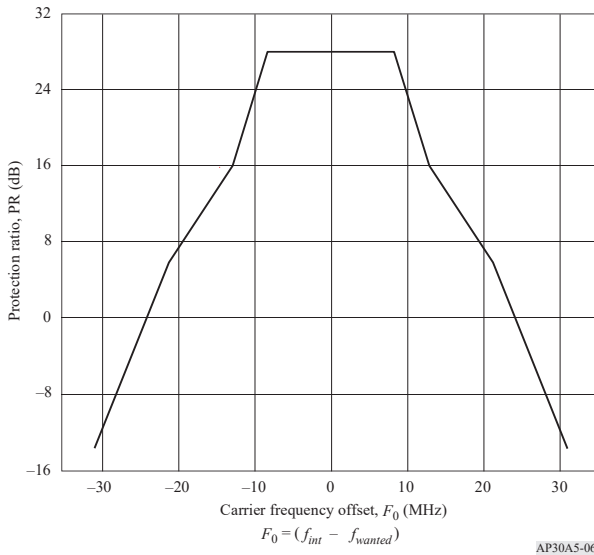

<sup>47</sup> See Annex 6 for the protection ratio template for interference between TV/FM signals in Regions 1 and 3.



The template is given by the following expressions:

$$PR = \begin{cases} 28 & \text{dB} & \text{for } |F_0| \leq 8.36 \text{ MHz} \\ -2.762 |F_0| + 51.09 & \text{dB} & \text{for } 8.36 < |F_0| \leq 12.87 \text{ MHz} \\ -1.154 |F_0| + 30.4 & \text{dB} & \text{for } 12.87 < |F_0| \leq 21.25 \text{ MHz} \\ -2.00 |F_0| + 48.38 & \text{dB} & \text{for } |F_0| > 21.25 \text{ MHz} \end{cases}$$

where  $PR$  is the protection ratio (dB) and  $|F_0|$  is the carrier spacing between the interfering and wanted signals (MHz).

### 3.5 Channel spacing

#### 3.5.1 Channel spacing in the Plans

In Regions 1 and 3, the spacing between the assigned frequencies of two adjacent channels is 19.18 MHz.

In Region 2, the spacing between the assigned frequencies of two adjacent channels is 14.58 MHz, which corresponds to 32 channels in the 500 MHz bandwidth allocated to the broadcasting-satellite service.

The Plans give the assigned frequencies for each channel.

However, in the Regions 1 and 3 Plan, for the implementation of assignments different frequency spacing may be used subject to the successful application of the modification procedure of Article 4, ITU-R Recommendations for protection masks should be used if available. In the absence of such Recommendations, the Bureau should apply the worst-case approach as adopted by the Radio Regulations Board.

#### 3.5.2 Arrangement of channels in the same beam

Planning in Region 1 at the 1977 Conference was carried out by trying to restrict all the channels radiated within a single antenna beam within a frequency range of 400 MHz, in order to simplify receiver construction. Such a restriction was considered unnecessary for the revision of the Regions 1 and 3 Plan at WRC-97.

#### 3.5.3 Spacing between assigned channel frequencies feeding a common antenna

In the 1977 Plan for Regions 1 and 3, owing to technical difficulties in the output circuit of a satellite transmitter, spacing between the assigned frequencies of two channels feeding a common antenna was required to be greater than 40 MHz. This restriction was not imposed in the revision of the Plan.

### 3.6 Figure of merit ( $G/T$ ) of a receiving station in the broadcasting-satellite service

In planning the broadcasting-satellite service, the value of the figure of merit  $G/T$  for clear-sky conditions is:

for Regions 1 and 3:

The original 1977 broadcasting-satellite service Plan used values<sup>48</sup> of:

- 6 dB(K<sup>-1</sup>) for individual reception
- 14 dB(K<sup>-1</sup>) for community reception, and

for Region 2:

- 10 dB(K<sup>-1</sup>) for individual reception.

The 1997 revision of the Regions 1 and 3 Plan is based on a uniform value of the figure of merit  $G/T$  equal to 11 dB(K<sup>-1</sup>).

These values were calculated from a formula which allows for pointing error, polarization effects and equipment ageing.

See also Report ITU-R BO.473-3 (Annex 1).

### 3.7 Receiving antennas

#### 3.7.1 Half-power beamwidth of receiving antennas

In the development of the original 1977 broadcasting-satellite service Plan for Regions 1 and 3, the minimum receiving antenna diameter was such that the half-power beamwidth was 2° for individual reception and 1° for community reception.

In revising this Plan at WRC-97, the minimum receiving antenna diameter was such that the half-power beamwidth was 2.86°. (WRC-07)

For planning the broadcasting-satellite service in Region 2, the minimum receiving antenna diameter must be such that the half-power beamwidth  $\phi_0$  is 1.7°.

#### 3.7.2 Receiving antenna reference patterns

The co-polar and cross-polar receiving antenna reference patterns are given in Figs. 7, 7bis and 8.

- a) For Regions 1 and 3, the original 1977 Conference Plan was based on the antenna pattern<sup>49</sup> shown in Fig. 7 where the relative antenna gain (dB) is given by the curves for:
- individual reception, for which use should be made of:
    - Curve A for the co-polar component;
    - Curve B for the cross-polar component;

<sup>48</sup> These values are still used for assignments notified, which are in conformity with this Appendix, brought into use, and for which the date of bringing into use has been confirmed to the Bureau before 27 October 1997.

<sup>49</sup> This antenna pattern is used in the broadcasting-satellite service Plan for Regions 1 and 3 for assignments notified, which are in conformity with this Appendix, brought into use, and for which the date of bringing into use has been confirmed to the Bureau before 27 October 1997.

- community reception, for which use should be made of:
  - Curve A' up to the intersection with Curve C, then Curve C, for the co-polar component;
  - Curve B for the cross-polar component.

The WRC-97 revision of the Regions 1 and 3 broadcasting-satellite service Plan was based on the absolute gain (dBi) patterns for a 60 cm antenna given in Recommendation ITU-R BO.1213 as shown in Fig. 7bis.

- b) For Region 2, the relative antenna gain (dB) is given by the curves in Fig. 8 for individual reception, for which use should be made of:
- Curve A for the co-polar component;
  - Curve B for the cross-polar component.

FIGURE 7  
Co-polar and cross-polar receiving antenna reference patterns  
in Regions 1 and 3

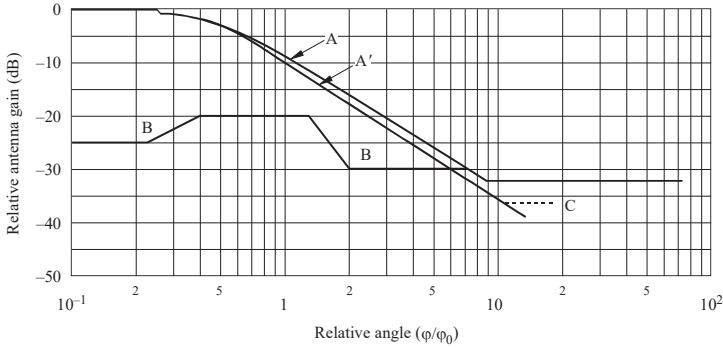

AP30A5-07

Curve A: co-polar component for individual reception without side-lobe suppression (dB relative to main beam gain)

0	for	0	≤	φ	≤	0.25 φ₀
$-12 \left( \frac{\phi}{\phi_0} \right)^2$	for	0.25 φ₀	<	φ	≤	0.707 φ₀
$- \left[ 9.0 + 20 \log \left( \frac{\phi}{\phi_0} \right) \right]$	for	0.707 φ₀	<	φ	≤	1.26 φ₀
$- \left[ 8.5 + 25 \log \left( \frac{\phi}{\phi_0} \right) \right]$	for	1.26 φ₀	<	φ	≤	9.55 φ₀
-33	for	φ < 9.55 φ₀				

- Curve A:* co-polar component for community reception without side-lobe suppression (dB relative to main beam gain)
- 0 for  $0 \leq \phi \leq 0.25 \phi_0$
  - $-12 \left( \frac{\phi}{\phi_0} \right)^2$  for  $0.25 \phi_0 < \phi \leq 0.86 \phi_0$
  - $- \left[ 10.5 + 25 \log \left( \frac{\phi}{\phi_0} \right) \right]$  for  $\phi > 0.86 \phi_0$  up to intersection with Curve C (then Curve C)
- Curve B:* cross-polar component for both types of reception (dB relative to main beam gain)
- 25 for  $0 \leq \phi \leq 0.25 \phi_0$
  - $- \left( 30 + 40 \log \left| \frac{\phi}{\phi_0} - 1 \right| \right)$  for  $0.25 \phi_0 < \phi \leq 0.44 \phi_0$
  - 20 for  $0.44 \phi_0 < \phi \leq 1.4 \phi_0$
  - $- \left( 30 + 25 \log \left| \frac{\phi}{\phi_0} - 1 \right| \right)$  for  $1.4 \phi_0 < \phi \leq 2 \phi_0$
  - 30 until intersection with co-polar component curve; then co-polar component curve.
- Curve C:* minus the on-axis gain (Curve C in this figure illustrates the particular case of an antenna with an on-axis gain of 37 dBi).

NOTE – For values of  $\phi_0$  see § 3.7.1.

FIGURE 7bis (WRC-03)  
**Reference receiving earth station antenna patterns used at WRC-97 for revising the Regions 1 and 3 broadcasting-satellite service Plan**

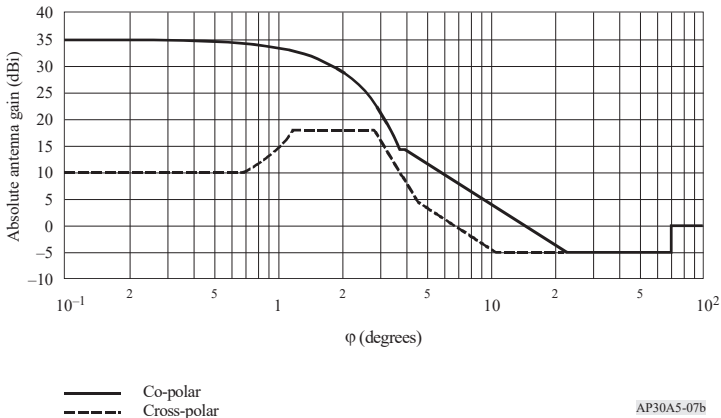

**AP30-126**

*Co-polar pattern:*

$$G_{co}(\varphi) = G_{max} - 2.5 \times 10^{-3} \left( \frac{D}{\lambda} \varphi \right)^2 \quad \text{for } 0 \leq \varphi < \varphi_m$$

where:

$$\varphi_m = \frac{\lambda}{D} \sqrt{\frac{G_{max} - G_1}{0.0025}}$$

$$G_{co}(\varphi) = G_1 = 29 - 25 \log \varphi_r \quad \text{for } \varphi_m \leq \varphi < \varphi_r$$

where:

$$\varphi_r = 95 \frac{\lambda}{D}$$

$$G_{co}(\varphi) = 29 - 25 \log \varphi \quad \text{for } \varphi_r \leq \varphi < \varphi_b$$

where:

$$\varphi_b = 10^{(34/25)}$$

$$G_{co}(\varphi) = -5 \text{ dBi} \quad \text{for } \varphi_b \leq \varphi < 70^\circ$$

$$G_{co}(\varphi) = 0 \text{ dBi} \quad \text{for } 70^\circ \leq \varphi < 180^\circ$$

*Cross-polar pattern:*

$$G_{cross}(\varphi) = G_{max} - 25 \quad \text{for } 0 \leq \varphi < 0.25 \varphi_0$$

where:

$$\varphi_0 = 2 \frac{\lambda}{D} \sqrt{\frac{3}{0.0025}} = 3 \text{ dB beamwidth}$$

$$G_{cross}(\varphi) = G_{max} - 25 + 8 \left( \frac{\varphi - 0.25 \varphi_0}{0.19 \varphi_0} \right) \quad \text{for } 0.25 \varphi_0 \leq \varphi < 0.44 \varphi_0$$

$$G_{cross}(\varphi) = G_{max} - 17 \quad \text{for } 0.44 \varphi_0 \leq \varphi < \varphi_0$$

$$G_{cross}(\varphi) = G_{max} - 17 + C \left| \frac{\varphi - \varphi_0}{\varphi_1 - \varphi_0} \right| \quad \text{for } \varphi_0 \leq \varphi < \varphi_1 \quad (\text{WRC-07})$$

where:

$\lambda$ : wavelength corresponding to 12.1 GHz (m)

$$C = 21 - 25 \log \varphi_1 - (G_{max} - 17)$$

$$\varphi_1 = \frac{\varphi_0}{2} \sqrt{10.1875}$$

$$G_{cross}(\varphi) = 21 - 25 \log \varphi \quad \text{for } \varphi_1 \leq \varphi < \varphi_2$$

where:

$$\varphi_2 = 10^{(26/25)}$$

$$G_{cross}(\varphi) = -5 \text{ dBi} \quad \text{for } \varphi_2 \leq \varphi < 70^\circ$$

$$G_{cross}(\varphi) = 0 \text{ dBi} \quad \text{for } 70^\circ \leq \varphi < 180^\circ$$

The reference frequency used in calculations for this antenna pattern = 12.1 GHz.

For the 0.60 m antenna pattern, which was used as a reference receiving antenna in replanning the absolute gain of 35.5 dBi was applied. (WRC-03)

FIGURE 8  
Reference patterns for co-polar and cross-polar components  
for receiving earth station antennas in Region 2

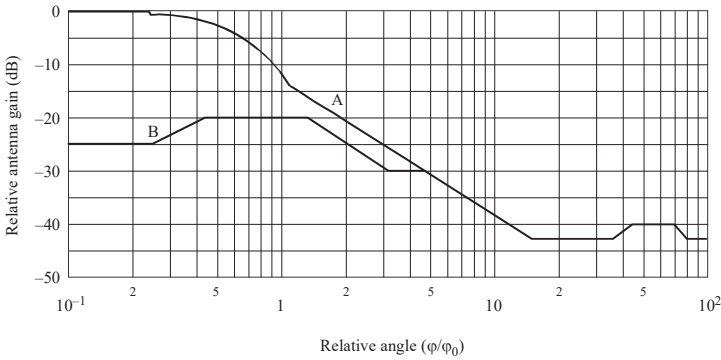

AP30A5-08

Curve A: co-polar component without side-lobe suppression (dB relative to main beam gain)

0	for	$0 \leq \phi \leq 0.25 \phi_0$
$-12 (\phi/\phi_0)^2$	for	$0.25 \phi_0 < \phi \leq 1.13 \phi_0$
$\{-14 + 25 \log (\phi/\phi_0)\}$	for	$1.13 \phi_0 < \phi \leq 14.7 \phi_0$
-43.2	for	$14.7 \phi_0 < \phi \leq 35 \phi_0$
$\{-85.2 - 27.2 \log (\phi/\phi_0)\}$	for	$35 \phi_0 < \phi \leq 45.1 \phi_0$
-40.2	for	$45.1 \phi_0 < \phi \leq 70 \phi_0$
$\{-55.2 + 51.7 \log (\phi/\phi_0)\}$	for	$70 \phi_0 < \phi \leq 80 \phi_0$
-43.2	for	$80 \phi_0 < \phi \leq 180^\circ$

Curve B: cross-polar component (dB relative to main beam gain)

-25	for	$0 \leq \phi \leq 0.25 \phi_0$
$\left( -30 + 40 \log \left  \frac{\phi}{\phi_0} - 1 \right  \right)$	for	$0.25 \phi_0 < \phi \leq 0.44 \phi_0$
-20	for	$0.44 \phi_0 < \phi \leq 1.28 \phi_0$
$\left( -17.3 + 25 \log \left  \frac{\phi}{\phi_0} \right  \right)$	for	$1.28 \phi_0 < \phi \leq 3.22 \phi_0$
-30	until intersection with co-polar component curve; then co-polar component curve.	

NOTE 1 – For values of  $\phi_0$  see § 3.7.1.

NOTE 2 – In the angular range between  $0.1 \phi_0$  and  $1.13 \phi_0$  the co-polar and cross-polar gains must not exceed the reference patterns.

NOTE 3 – At off-axis angles larger than  $1.13 \phi_0$  and for 90% of all sidelobe peaks in each of the reference angular windows, the gain must not exceed the reference patterns. The reference angular windows are  $1.13 \phi_0$  to  $3 \phi_0$ ,  $3 \phi_0$  to  $6 \phi_0$ ,  $6 \phi_0$  to  $10 \phi_0$ ,  $10 \phi_0$  to  $20 \phi_0$ ,  $20 \phi_0$  to  $40 \phi_0$ ,  $40 \phi_0$  to  $75 \phi_0$  and  $75 \phi_0$  to  $180^\circ$ .

### 3.8 Necessary bandwidth

WARC-77 Regions 1 and 3 Plan and the WRC-97 revision of the Regions 1 and 3 Plan used the following:

- 625-line systems in Regions 1 and 3: 27 MHz;
- 525-line systems in Region 3: 27 MHz. (WRC-2000)

The planning at WRC-2000 was generally based on a necessary bandwidth of 27 MHz. (WRC-2000)

In Region 2, the Plan is based on a channel bandwidth of 24 MHz<sup>50</sup>, but different bandwidths may be implemented in accordance with the provisions of this Appendix, provided that applicable ITU-R Recommendations are available. In the absence of such Recommendations, the Bureau will use the worst-case approach. (WRC-2000)

If different bandwidths and/or channel spacing are submitted, they will be treated in accordance with applicable ITU-R Recommendations for protection masks when available. In the absence of such Recommendations, the Bureau will use the worst-case approach. (WRC-2000)

### 3.9 Guardbands

3.9.1 A guardband is defined as the portion of the frequency spectrum between the edge of the allocated band and the edge of the necessary bandwidth of the emission in the nearest channel.

3.9.2 For the planning of the broadcasting-satellite service, the guardbands chosen at the 1977 Conference to protect the services in adjacent frequency bands are shown in the Table below.

Regions	Guardband at the lower edge of the band (MHz)	Guardband at the upper edge of the band (MHz)
1	14	11
2	12	12
3	14	11

For Regions 1 and 3 at WARC-77, the guardbands were derived on the assumption of analogue emissions and a maximum beam centre e.i.r.p. of 67 dBW (value relating to individual reception), and a filter roll-off of 2 dB/MHz. If smaller e.i.r.p. values are assumed, the guardbands can be reduced in width by 0.5 MHz for each decibel decrease in e.i.r.p. The degree of possible reduction also depends on improvements in technology and on the type of modulation. (WRC-2000)

3.9.3 (SUP - WRC-97)

---

<sup>50</sup> For France, Denmark and some of the United Kingdom requirements which use 625-line standards with greater video bandwidth, the channels shown in the Plan have a necessary bandwidth of 27 MHz. This is indicated by an appropriate symbol in the Plan.

3.9.4 The guardbands at both the lower and upper edges may be used to provide space operation functions in accordance with No. 1.23 in support of the operation of geostationary-satellite networks in the broadcasting-satellite service. (WRC-03)

### 3.10 Orbital spacing

The Plan for Regions 1 and 3 has been based generally on nominal orbital positions spaced uniformly at intervals of  $6^\circ$ . The Plan for Region 2 has been based on a non-uniform spacing.

### 3.11 Satellite station-keeping

Space stations in the broadcasting-satellite service must be maintained in position with an accuracy equal to or better than  $\pm 0.1^\circ$  in the E-W directions. For such space stations, the maintenance of the tolerance  $\pm 0.1^\circ$  in the N-S direction is recommended but is not a requirement.

### 3.12 Elevation angle of receiving antennas

The Plans have been based on the desirability of a minimum angle of elevation of  $20^\circ$  to minimize the required e.i.r.p. of the satellite and to reduce the effects of shadowing and the possibility of interference from terrestrial services. However, for areas situated in latitudes above about  $60^\circ$ , the angle of elevation is of necessity less than  $20^\circ$ . Attention is also drawn to § 2.1 for the Regions 1 and 3 Plan and to § 2.2.3 for the Region 2 Plan.

For mountainous areas where an elevation angle of  $20^\circ$  may not suffice, an angle of at least  $30^\circ$  has been provided, where possible, to provide an acceptable service. An angle of elevation of at least  $40^\circ$  has been considered for service areas subject to high precipitation, but exceptions were made in some cases in Region 2.

Some dry, non-mountainous areas may be given an acceptable service at angles of elevation less than  $20^\circ$ .

In areas with small elevation angles, the shadowing effect of tall buildings may have to be taken into account.

In choosing a satellite position designed to give the maximum angle of elevation at the ground, the influence of such a position on the eclipse period was taken into account at the 1977 Conference. In the revision of the Regions 1 and 3 Plan at WRC-97, this influence was not considered to be a significant constraint on the choice of orbital position.

### 3.13 Transmitting antennas

#### 3.13.1 Cross-section of transmitted beam

Planning in Regions 1, 2 and 3 has been generally based on the use of satellite transmitting antennas with beams of elliptical cross-section.

If the cross-section of the emitted beam is elliptical, the effective beamwidth  $\varphi_0$  is a function of the angle of rotation between the plane containing the satellite and the major axis of the beam cross-section and the plane in which the beamwidth is required.



The relationship between the maximum gain of an antenna and the half-power beamwidth can be derived from the expression:

$$G_m = \frac{27\,843}{ab}$$

where:

$a$  and  $b$  are the angles (degrees) subtended at the satellite by the major and minor axes of the elliptical cross-section of the beam; an antenna efficiency of 55% was assumed.

However, in implementing their assignments, administrations can choose beams other than elliptical, as described in Annex 2 to this Appendix, subject to successful application of the modification procedure of this Appendix.

### 3.13.2 Minimum beamwidth of transmitting antenna

A minimum value of  $0.6^\circ$  for the half-power beamwidth of a transmitting antenna has been adopted for planning for Regions 1 and 3, and  $0.8^\circ$  for Region 2.

### 3.13.3 Transmitting antenna reference patterns

The reference patterns for the co-polar and cross-polar components of satellite transmitting antennas used in preparing the Plans are given in Fig. 9 for Regions 1 and 3, and in Fig. 10 for Region 2.

FIGURE 9  
Reference patterns for co-polar and cross-polar components  
for satellite transmitting antennas in Regions 1 and 3

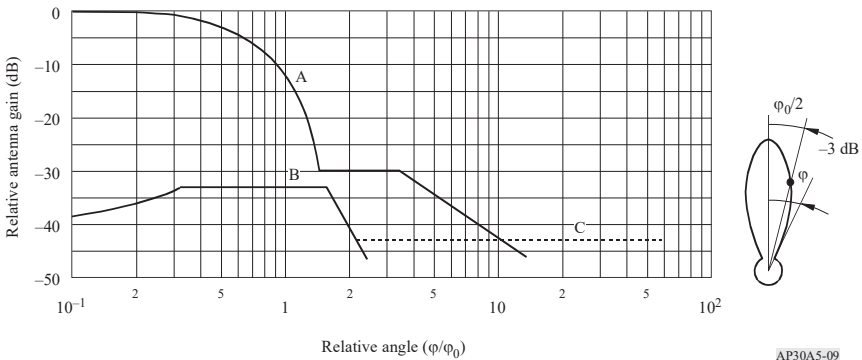

AP30A5-09

Curve A: co-polar component (dB relative to main beam gain)

$$\begin{aligned}
 & -12 \left( \frac{\phi}{\phi_0} \right)^2 && \text{for } 0 \leq \phi \leq 1.58 \phi_0 \\
 & -30 && \text{for } 1.58 \phi_0 < \phi \leq 3.16 \phi_0 \\
 & - \left[ 17.5 = 25 \log \left( \frac{\phi}{\phi_0} \right) \right] && \text{for } \phi > 3.16 \phi_0
 \end{aligned}$$

after intersection with Curve C: as Curve C

Curve B: cross-polar component (dB relative to main beam gain)

$$\begin{aligned}
 & -\left(40 + 40 \log \left| \frac{\varphi}{\varphi_0} - 1 \right| \right) && \text{for } 0 \leq \varphi \leq 0.33 \varphi_0 \\
 & -33 && \text{for } 0.33 \varphi_0 < \varphi \leq 1.67 \varphi_0 \\
 & -\left(40 + 40 \log \left| \frac{\varphi}{\varphi_0} - 1 \right| \right) && \text{for } \varphi > 1.67 \varphi_0
 \end{aligned}$$

after intersection with Curve C: as Curve C

Curve C: minus the on-axis gain (Curve C in this figure illustrates the particular case of an antenna with an on-axis gain of 43 dBi).

FIGURE 10  
**Reference patterns for co-polar and cross-polar components  
 for satellite transmitting antennas in Region 2**

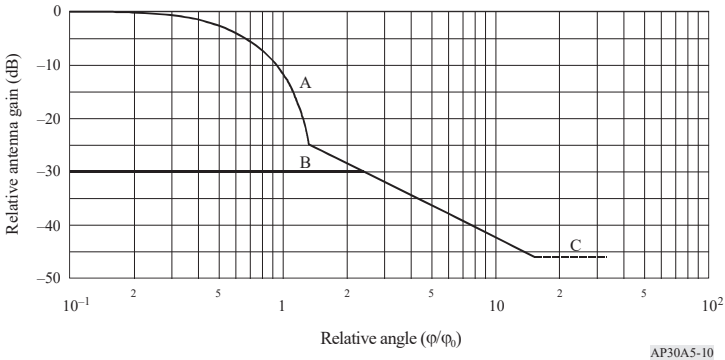

Curve A: co-polar component (dB relative to main beam gain)

$$\begin{aligned}
 & -12 \left( \frac{\varphi}{\varphi_0} \right)^2 && \text{for } 0 \leq \left( \frac{\varphi}{\varphi_0} \right) \leq 1.45 \\
 & -\left( 22 + 20 \log \left( \frac{\varphi}{\varphi_0} \right) \right) && \text{for } \left( \frac{\varphi}{\varphi_0} \right) > 1.45
 \end{aligned}$$

after intersection with Curve C: Curve C

Curve B: cross-polar component (dB relative to main beam gain)

$$-30 \quad \text{for } 0 \leq \left( \frac{\varphi}{\varphi_0} \right) \leq 2.51$$

after intersection with co-polar pattern: co-polar pattern

Curve C: minus the on-axis gain (Curve C in this figure illustrates the particular case of an antenna with an on-axis gain of 46 dBi).

In Region 2, when it was necessary to reduce interference, the pattern shown in Fig. 11A was used; this use is indicated in the Plan by an appropriate symbol. This pattern is derived from an antenna producing an elliptical beam with fast roll-off in the main lobe assuming a “beamlet” half-power beamwidth of 0.8°. For Regions 1 and 3, the pattern shown in Fig. 11B, based on a “beamlet” beamwidth of 0.6° was used. Curves for three different values of  $\phi_0$  are shown as examples in Fig. 11A and in Fig. 11B.

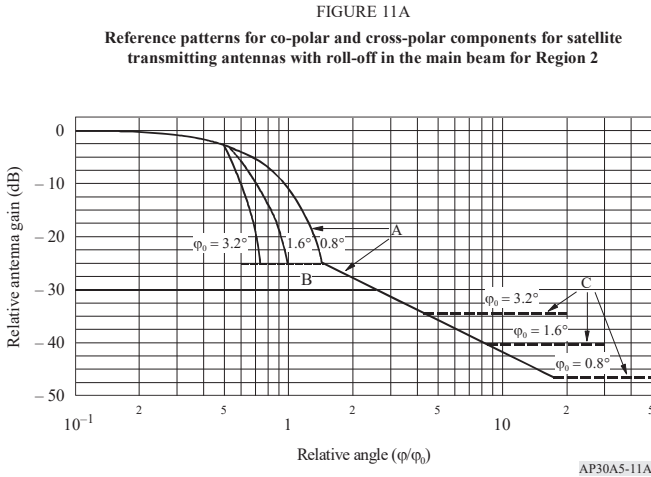

Curve A: co-polar component (dB relative to main beam gain)

$$\begin{aligned}
 & -12 \left( \frac{\phi}{\phi_0} \right)^2 && \text{for } 0 \leq (\phi/\phi_0) \leq 0.5 \\
 & -12 \left( \frac{\frac{\phi}{\phi_0} - x}{\frac{B_{min}}{\phi_0}} \right)^2 && \text{for } 0.5 < (\phi/\phi_0) \leq \left( \frac{1.45}{\phi_0} B_{min} + x \right) \\
 & -25.23 && \text{for } \left( \frac{1.45}{\phi_0} B_{min} + x \right) < (\phi/\phi_0) \leq 1.45 \\
 & - \left( 22 + 20 \log \left( \frac{\phi}{\phi_0} \right) \right) && \text{for } (\phi/\phi_0) > 1.45
 \end{aligned}$$

after intersection with Curve C: Curve C

Curve B: cross-polar component (dB relative to main beam gain)

$$-30 \qquad \text{for } 0 \leq (\phi/\phi_0) < 2.51$$

after intersection with co-polar pattern: co-polar pattern

Curve C: minus the on-axis gain (Curves A and C represent examples of three antennas having different values of  $\varphi_0$  as labelled in Fig. 11A. The on-axis gains of these antennas are approximately 34, 40 and 46 dBi, respectively).

where:

$\varphi$  : off-axis angle (degrees)

$\varphi_0$  : dimension of the minimum ellipse fitted around the downlink service area in the direction of interest (degrees)

$B_{min} = 0.8^\circ$  for Region 2 and  $B_{min} = 0.6^\circ$  for Regions 1 and 3

$$x = 0.5 \left( 1 - \frac{0.8}{\varphi_0} \right) \quad \text{in Region 2}$$

$$x = 0.5 \left( 1 - \frac{0.6}{\varphi_0} \right) \quad \text{in Regions 1 and 3}$$

FIGURE 11B  
Fast roll-off antenna for Regions 1 and 3 Plan revision  
(beamlet beamwidth of  $0.6^\circ$ )

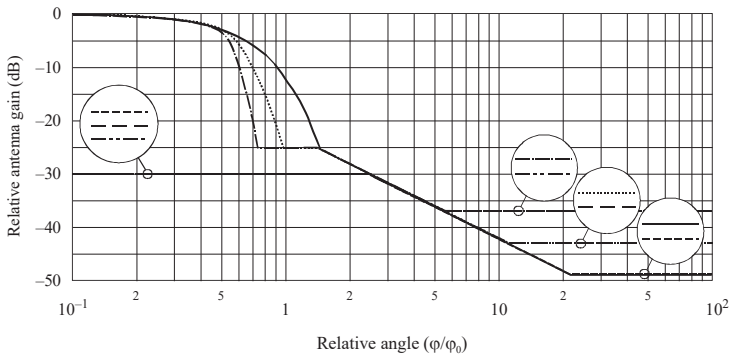

- Beamwidth  $0.6^\circ$  - co-polar
- ..... Beamwidth  $1.2^\circ$  - co-polar
- Beamwidth  $2.4^\circ$  - co-polar
- Beamwidth  $0.6^\circ$  - cross-polar
- Beamwidth  $1.2^\circ$  - cross-polar
- Beamwidth  $2.4^\circ$  - cross-polar

AP30A5-11b

The difference in performance between the fast roll-off satellite transmitting antenna and the reference satellite transmitting antenna for Regions 1 and 3 is shown in Fig. 12.

FIGURE 12  
 Comparison between fast roll-off and Regions 1 and 3  
 reference satellite transmitting antennas

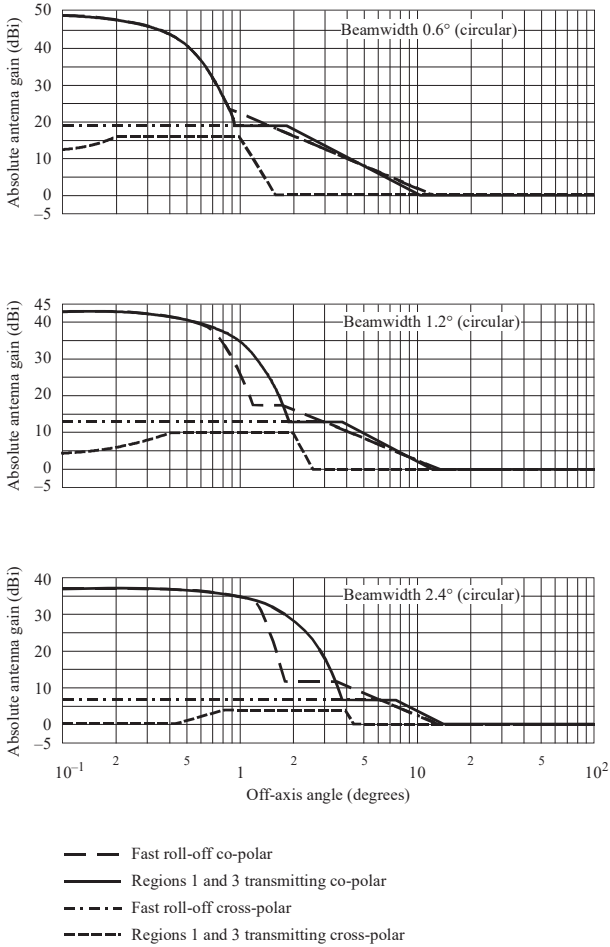

AP30A5-12

The improved fast roll-off satellite transmitting antenna pattern described in Recommendation ITU-R BO.1445 (see Fig. 13) has been used in the planning at WRC-2000. (WRC-2000)

FIGURE 13 (Rev.WRC-03)

**Improved fast roll-off satellite transmitting antenna pattern for Regions 1 and 3**

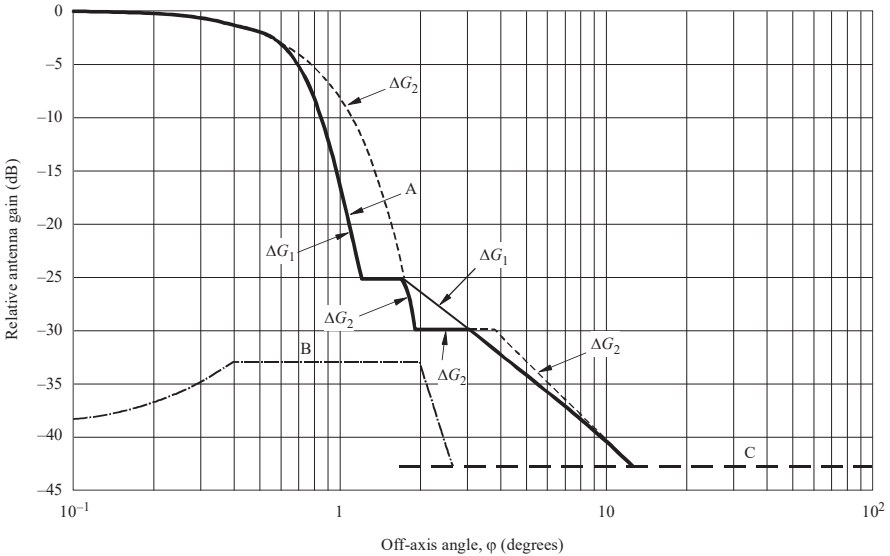

- Regions 1 and 3 transmitting fast roll-off co-polar (Curve  $\Delta G_1$ )
- Improved fast roll-off co-polar (Curve A defined as  $\Delta G$  below)
- - - - - Regions 1 and 3 transmitting co-polar (Curve  $\Delta G_2$ )
- · - · - Improved fast roll-off cross-polar (Regions 1 and 3 transmitting cross-polar) (Curve B)
- - - - - Curve C (minus the on-axis gain)

Note 1 – The diagram gives the example curves in the case of a satellite antenna beamwidth of  $\varphi_0 = 1.2^\circ$  (circular).

AP30A5-13

Curve A: co-polar relative gain (dB relative to main beam gain):

$$\Delta G = \min(\Delta G_1, \Delta G_2)$$

where:

$$\Delta G_1 = -12 \left( \varphi / \varphi_0 \right)^2 \quad \text{for } 0 \leq (\varphi / \varphi_0) \leq 0.5$$

$$\Delta G_1 = -12 \left( \frac{\frac{\varphi}{\varphi_0} - x}{\frac{B_{min}}{\varphi_0}} \right)^2 \quad \text{for } 0.5 < (\varphi / \varphi_0) \leq \left( \frac{1.45}{\varphi_0} B_{min} + x \right) \quad \text{(WRC-2000)}$$

$$\Delta G_1 = -25.23 \quad \text{for } \left( \frac{1.45}{\varphi_0} B_{min} + x \right) < (\varphi / \varphi_0) \leq 1.45 \quad \text{(WRC-03)}$$

$$\begin{aligned} \Delta G_1 &= -(22+20 \log(\varphi/\varphi_0)) && \text{for } (\varphi/\varphi_0) > 1.45 \\ \Delta G_1 &= -(G_{on-axis}) && \text{after intersection with Curve C} \\ \Delta G_2 &= -12(\varphi/\varphi_0)^2 && \text{for } 0 \leq \varphi \leq 1.58 \varphi_0 \\ \Delta G_2 &= -30 && \text{for } 1.58 \varphi_0 < \varphi \leq 3.16 \varphi_0 \\ \Delta G_2 &= -(17.5+25 \log(\varphi/\varphi_0)) && \text{for } \varphi > 3.16 \varphi_0 \\ \Delta G_2 &= -(G_{on-axis}) && \text{after intersection with Curve C} \end{aligned}$$

Curve B: cross-polar relative gain (dB):

$$\begin{aligned} &-\left(40+40 \log\left|\frac{\varphi}{\varphi_0}-1\right|\right) && \text{for } 0 \leq \varphi \leq 0.33 \varphi_0 \\ -33 &&& \text{for } 0.33 \varphi_0 < \varphi \leq 1.67 \varphi_0 \\ &-\left(40+40 \log\left|\frac{\varphi}{\varphi_0}-1\right|\right) && \text{for } \varphi > 1.67 \varphi_0 \\ &-(G_{on-axis}) && \text{after intersection with Curve C} \end{aligned}$$

Curve C: minus the on-axis gain (Curve C in this Figure illustrates the particular case of an antenna with an on-axis gain of 42.8 dBi)

where:

$$\begin{aligned} \varphi: & \text{ off-axis angle (degrees)} \\ \varphi_0: & \text{ cross-sectional half-power beamwidth in the direction of interest (degrees)} \\ B_{min}: & 0.6^\circ \quad \text{for Regions 1 and 3} \\ x = 0.5 \left(1 - \frac{B_{min}}{\varphi_0}\right) & \hspace{10em} \text{(WRC-2000)} \end{aligned}$$

### 3.13.4 Composite beam

A composite beam represents a single beam (i.e. “simulated shaped beam”) and is formed by combining two or more elliptical beams at a given orbital position. In general, composite beams were used at WRC-2000 for administrations which had more than one beam at a given orbital position in the WRC-97 Regions 1 and 3 Plan. (WRC-2000)

### 3.14 Satellite antenna pointing accuracy

3.14.1 The deviation of the antenna beam from its nominal pointing direction must not exceed a limit of 0.1° in any direction. Moreover, the angular rotation of a transmitting beam about its axis must not exceed a limit of ±1°; the limit on rotation is not necessary for beams of circular cross-section using circular polarization<sup>51</sup>.

---

<sup>51</sup> In the original 1977 broadcasting-satellite service Plan for Regions 1 and 3, the angular rotation of a transmitting beam about its axis must not exceed a limit of ±2°. This limit is still applied for assignments notified, which are in conformity with this Appendix, brought into use, and for which the date of bringing into use has been confirmed to the Bureau before 27 October 1997.

3.14.2 The following factors contribute to the total variation in the area on the surface of the Earth illuminated by the satellite beam:

- variations in satellite station-keeping;
- the variations caused by the pointing tolerances, which become more significant for coverage areas with low angles of elevation;
- the effect of the yaw error, which increases as the beam ellipse lengthens.

3.14.3 The effect of these possible variations should be assessed on a case-by-case basis, since their total effect on the area covered will vary with the geometry of the satellite beam, and it would not be reasonable to indicate a single value of shift in the area covered for all situations.

3.14.4 If linear polarization is used for an emission, yaw error makes a significant contribution to increasing the transmitted cross-polarized component; this increases the interference with other carriers which were originally cross-polarized with the emission in question.

### **3.15 Limitation of output power in the satellite transmitter**

The output power of a space station transmitter in the broadcasting-satellite service must not rise by more than 0.25 dB relative to its nominal value throughout the life of the satellite.

### **3.16 Power flux-density at edge of coverage area**

The original 1977 broadcasting-satellite service Plan used the following values<sup>52</sup> of the power flux-density at the edge of the coverage area exceeded for 99% of the worst month:

- 103 dB(W/m<sup>2</sup>) for individual reception in Regions 1 and 3;
- 107 dB(W/m<sup>2</sup>) for individual reception in Region 2 for 24 MHz, as well as for 27 MHz with respect to the cases mentioned in the footnote to § 3.8.
- 111 dB(W/m<sup>2</sup>) for community reception in Regions 1 and 3.

The 1997 revision of the Regions 1 and 3 Plan was generally based on a uniform value of the power flux-density at the edge of coverage area equal to –108 dB(W/m<sup>2</sup>). This corresponds to the general reduction in e.i.r.p. of 5 dB referenced to the average e.i.r.p. of 63.9 dBW in the 1977 broadcasting-satellite service Plan.

### **3.17 Difference between the e.i.r.p. directed towards the edge of the coverage area and that on the axis of the beam**

For planning, the absolute value of the difference between the e.i.r.p. directed towards the edge of the coverage area and that on the axis of the beam should preferably be 3 dB.

If the beam area is larger than the coverage area, the value will be less than 3 dB.

---

<sup>52</sup> These values are still used for assignments notified, which are in conformity with this Appendix, brought into use, and for which the date of bringing into use has been confirmed to the Bureau before 27 October 1997.



### 3.18 Use of energy dispersal

For planning, an energy dispersal value has been adopted which reduces by 22 dB the spectral power flux-density measured in a 4 kHz bandwidth in relation to that measured in the entire bandwidth: For frequency-modulated television signals, this reduction corresponds to a peak-to-peak deviation of 600 kHz. Digital modulation can achieve appropriate energy dispersal by proper implementation of digital modulation (e.g. by applying spectrum scrambling and/or interleaving).

### 3.19 Orbital separation limit for interference calculation

WRC-2000 has adopted the use of an orbital separation limit for interference calculation in Regions 1 and 3. Beyond this limit no interference was taken into account.

Initially, the values used for the orbital separation limit were 15° for co-polar and 9° for cross-polar emissions. At a later stage, the unique value of the orbital separation limit of 9° was adopted by WRC-2000. (WRC-2000)

## ANNEX 6<sup>53</sup> (WRC-03)

### Criteria for sharing between services

#### Part A – Technical bases for the criteria for interregional sharing between space services in Annexes 1 and 4

The revised interregional sharing criteria in the bands governed by Appendix 30 are based nominally on the following assumptions.

### 1 Reference assumptions regarding earth station antenna patterns

1.1 For earth station antennas with diameters between 0.45 m and 2.40 m, the gain of the side lobes given by Recommendation ITU-R BO.1213 were used.

For the patterns of earth station antennas with diameters greater than 2.40 m, the gain of the side lobes given by Recommendation ITU-R S.580-5, with a  $(29 - 25 \log \theta)$  side-lobe envelope, complemented by the main-lobe given in Annex 3 to Appendix 8, were used.  $\theta$  is the off-axis angle in degrees.

1.2 For the broadcasting-satellite service and fixed-satellite service earth stations, an antenna efficiency of 65% was used at a frequency of 11.7 GHz.

---

<sup>53</sup> Sections 1 and 2 are applicable when the services of Regions 1 or 3 are involved. Section 3 is applicable to all Regions.

## 2 Antenna diameters and noise temperatures

The range of antenna diameters and associated noise temperatures considered for the protection of the fixed-satellite service and the broadcasting-satellite service on an interregional basis are given in the following table:

Receive earth station antenna diameter (m)	0.45 <sup>1</sup>	0.60	0.80	1.20	2.40	5 <sup>2</sup>	8 <sup>2</sup>	11 <sup>2</sup>
Receive earth station noise temperature (K)	110	110	125	150	150	200	250	250
Total link noise temperature (K)	174	174	198	238	238	317	396	396

<sup>1</sup> This antenna diameter applies in certain cases (see Annexes 1, 3 and 4).

<sup>2</sup> This antenna diameter does not apply for broadcasting-satellite service.

The total link noise temperature was calculated from the receive earth station noise temperature (which includes the antenna temperature, the receive amplifier temperature and the noise increase resulting from feeder losses), and adding 2 dB to take account of all other sources of noise (uplink noise, geostationary-satellite orbit interference, cross polarization isolation and frequency reuse interference).

## 3 Protection criteria

The power flux-density masks developed in sections 1, 3 and 6 of Annex 1 and in Annex 4 have been determined by setting at 6% the allowable relative noise increase ( $\Delta T/T$ ), for the earth station antenna characteristics given in the above Table.

The allowable interfering power flux-density was calculated by the following expression:

$$PF_{D_{all}}(\theta) = 10 \log(\Delta T/T) + 10 \log(k T b_{rf}) + G_m - G_a(\varphi)$$

where:

$PF_{D_{all}}(\theta)$ : allowable level of interfering power flux-density for an orbital separation of  $\theta^\circ$

$\Delta T/T$ : allowable relative increase in receive link noise = 6%

$k$ : Boltzmann's constant ( $1.38 \times 10^{-23}$  J/K)

$T$ : receive link noise temperature (K) (see Table in section 2 above)

$b_{rf}$ : reference bandwidth (27 MHz in Regions 1 and 3; 24 MHz in Region 2)

$G_m$ : gain for a 1 m<sup>2</sup> effective aperture (dBi/m<sup>2</sup>)

$G_a(\varphi)$ : receive antenna gain for topocentric angle of  $\varphi$  (dBi)

$\varphi$ : topocentric angle (degrees) between the interfering and the wanted satellite, as defined in Annex 1 of Appendix 8.

#### 4 Power flux-density levels for fixed-satellite service and broadcasting-satellite service with specific antenna diameters

The table below contains power flux-density levels derived for fixed-satellite service and broadcasting-satellite service earth stations with specific antenna diameters for the characteristics defined in sections 1, 2 and 3 above. These levels were used to develop the power flux-density masks in sections 1, 3 and 6 of Annex 1 and in Annex 4 by taking the envelope of the individual pfd masks for the relevant antenna diameters.

Orbital separation between wanted and interfering space stations (degrees)	Power flux-density level in dB(W/(m <sup>2</sup> · 27 MHz)) corresponding to different antenna diameters							
	0.45 m <sup>1</sup>	0.60 m	0.80 m	1.20 m	2.40 cm	5 m <sup>2</sup>	8 m <sup>2</sup>	11 m <sup>2</sup>
0°	-134.2	-136.7	-138.7	-141.4	-147.4	-152.5	-155.7	-158.4
θ > 0°	For any value of the orbital separation θ between the wanted and interfering space stations, the applicable power flux-density should be relaxed from the value corresponding to 0° orbital separation by adding the off-axis antenna discrimination, as calculated under the assumptions in section 1 above							

<sup>1</sup> This antenna diameter applies to certain cases (see Annexes 1, 3 and 4).

<sup>2</sup> This antenna diameter does not apply for broadcasting satellite service.

### Part B – Sharing criteria used in establishing the WARC SAT-77 Plan

#### 1 Protection requirements for sharing between services in the 12 GHz band

1.1 The establishment of sharing criteria for the different services using the 12 GHz band should be based on the protection requirements listed in the table below.

1.2 The values given as “total acceptable” are those necessary to protect the wanted signal. The “single entry” values are those which should be used as a guide for determining sharing criteria. The total interference from all sources must be calculated, since satisfying the “single entry” criteria for each source may not guarantee that the total interference meets the above protection requirements. A “single entry” is defined as the aggregate of emissions from any one station entering any receiver in the wanted service within the channel to be protected.

1.3 The carrier-to-interference ratio ( $C/I$ ) refers to the ratio of the wanted-to-interfering power at the affected ground station. The value given shall be exceeded for 80% of the worst month for the fixed-satellite service, and for 99% of the worst month for the broadcasting service and the broadcasting-satellite service.

1.4 The term  $N$  refers to the post-demodulation noise power at a point of 0 dBm0 relative test tone level in any voice channel of an FDM/FM telephony system. The value given shall not be exceeded for 80% of the worst month.

1.5 The specified values of protection ratio (i.e., the carrier-to-interference power ratio corresponding to a specified picture quality) are applicable, for planning purposes, to television signals of any of the several television standards.

Wanted service <sup>1</sup>	Wanted signal <sup>1</sup>	Interfering service <sup>1</sup>	Interfering signal <sup>1</sup>	Protection requirements <sup>2</sup>	
				Total acceptable <sup>3</sup>	Single entry
BSS	TV/FM	BSS, FSS, FS, BS	TV/FM	$C/I = 30$ dB <sup>4,7</sup>	$C/I = 35$ dB <sup>4</sup>
FSS	FDM/FM	BSS	TV/FM	$N = 500$ pW0p <sup>8</sup>	$N = 300$ pW0p
FSS	TV/FM	BSS, FSS	TV/FM	$C/I = 32$ dB <sup>5</sup>	$C/I = 37$ dB <sup>5</sup>
FSS	4φ-PSK	BSS, FSS	TV/FM	$C/I = 30$ dB	$C/I = 35$ dB
FSS	FDM/FM	FSS	FDM/FM	$N = 1\,000$ pW0p	$N = 400$ pW0p
FS	FDM/FM	BSS	TV/FM	$N = 1\,000$ pW0p	$-125$ dB(W/(m <sup>2</sup> · 4 kHz)) <sup>6</sup>
BS	TV/VSB	BSS	TV/FM	$C/I = 50$ dB	Not applicable

- <sup>1</sup> BSS: broadcasting-satellite service      FM: frequency modulation
- FSS: fixed-satellite service              FDM: frequency division multiplex
- BS: broadcasting service                    4φ-PSK: quadrature phase shift keying
- FS: fixed service                              VSB: vestigial sideband.
- TV: television

<sup>2</sup> These limits include both up-link and down-link contributions.

<sup>3</sup> Values (dB) are protection ratios for the sum of interfering signals. Values (pW0p) represent interference noise in the worst telephone channels caused by the sum of interfering signals.

<sup>4</sup> For BSS satellites located at the interfaces of the Regions 1 and 3 Plan and the Region 2 Plan, the  $C/I$  ratios should be 1 dB higher.

<sup>5</sup> See Recommendation ITU-R S.483-3.

<sup>6</sup> This value may be suitably modified for tropical regions to take account of rain attenuation. Allowance may also be made for polarization discrimination.

<sup>7</sup>  $C/I$ : ratio of carrier-to-interfering signal.

<sup>8</sup>  $N$ : noise power.

1.6 For broadcasting-satellite service systems with FM/TV as the wanted signal, the protection ratios are given for particular reference conditions, the most important of which are:

- a) frequency deviation of the wanted signal (12 MHz peak-to-peak);
- b) quality of the wanted service (grade 4.5)<sup>54</sup>;
- c) co-channel carriers (no carrier-frequency offset).

1.7 If system design is based on conditions other than those of § a) and b) above, the FM/TV protection ratio is given by:

$$R = 12.5 - 20 \log(D_v/12) - Q + 1.1 Q^2 \quad \text{dB}$$

<sup>54</sup> Impairment grade on a 5-point scale as defined in Recommendation ITU-R BT.500-7.

where:

$D_V$ : nominal peak-to-peak frequency deviation (MHz);

$Q$ : the impairment grade, concerning the interference only.

1.8 When carriers are offset in frequency, condition of § c) does not apply and the adjacent channel protection ratios should be adjusted according to the frequency offset as shown in Fig. 1. For example, at a frequency offset of 20 MHz, the total acceptable ratio of protection against interference to an FM/TV signal from another FM/TV signal is 13 dB. The corresponding “single entry” value is 18 dB.

FIGURE 1  
Reference case protection ratios relative to co-channel values

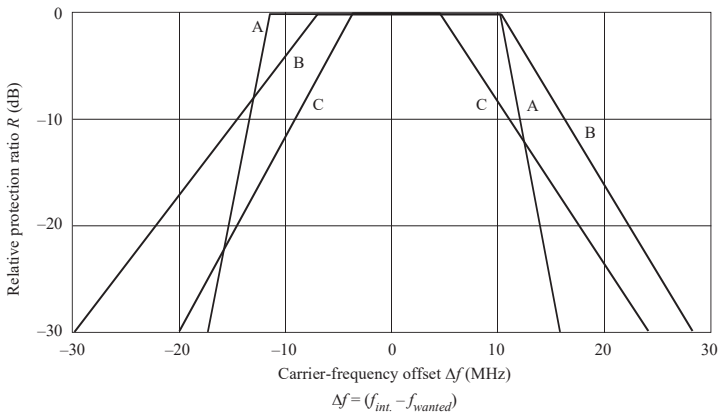

Curves A : TV/VSB-wanted, TV/FM interfering  
 B : TV/FM-wanted, TV/FM interfering  
 C : TV/FM-wanted, TV/VSB interfering

AP30A6-01

## 2 Reference antenna diameter for a fixed-satellite earth station to be used in calculating interference from space stations in the broadcasting-satellite service

2.1 For antennas larger than  $100 \lambda$  (2.5 m) in the fixed-satellite service, the gain of the side-lobes is given by the expression  $32 - 25 \log \theta$ , where  $\theta$  is the angle from the boresight (Recommendation ITU-R S.465-5). The side-lobe gain is independent of antenna diameter.

2.2 However, in the case of transmitting earth stations, the level of interference radiated into the up-link of other satellite systems would be inversely proportional to the square of the antenna diameter. In this case, the interference decreases with increasing antenna diameter. Since the 11.7-12.2 GHz band is only assigned in the space-to-Earth direction in the fixed-satellite service, this point is not of direct concern to the broadcasting-satellite service.

2.3 Hence it does not appear appropriate, for antenna diameters greater than  $100 \lambda$ , to specify a minimum antenna diameter for receiving earth stations in the fixed-satellite service sharing the band 11.7-12.2 GHz. It may be useful to consider a 4.5 m antenna having an efficiency of 60% and an on-axis gain of 53 dB as typical for the purpose of planning the sharing of this band.

### 3 Use of energy dispersal in the broadcasting-satellite service

3.1 Artificial energy dispersal is useful in promoting sharing between the broadcasting-satellite service and the other services to which the band is also allocated.

3.2 Such energy dispersal is achieved by the addition at baseband of a triangular waveform to the video signal to form a composite baseband which, in turn, is used to frequency-modulate the up-link carrier. The frequency of the triangular waveform is usually synchronized at a sub-multiple of the television frame frequency. Typical frequencies range from 12.5 Hz to 30 Hz.

3.3 The Table below gives the relative reduction in spectral power flux-density in a 4 kHz bandwidth as a function of the peak-to-peak deviation due to the energy dispersal signal. This Table is based on the following equation:

$$\text{Relative reduction (dB) in a 4 kHz band} = 10 \log \frac{\Delta F_{pp} + \delta f_{rms}}{4}$$

where:

$\Delta F_{pp}$ : peak-to-peak deviation due to the energy dispersal signal (kHz);

$\delta f_{rms}$ : rms deviation due to “natural” energy dispersal (kHz).

In compiling the table below, a value of 40 kHz has been assumed for  $\delta f_{rms}$ , on the basis of the value of 10 dB for “natural” dispersion given in Table IV of ex-CCIR Report 631\* (Rev.76).

**Reduction of spectral power flux-density relative to a 4 kHz bandwidth**

Peak-to-peak deviation (kHz)	Relative reduction (dB)
0	10
100	15.44
200	17.78
300	19.29
400	20.41
500	21.30
600	22.04
700	22.67
800	23.22
900	23.71
1 000	24.15

\* Note by the Secretariat: See Report ITU-R BO.631.

3.4 The value of energy dispersal for the broadcasting-satellite service has been determined such that the spectral power flux-density measured in a 4 kHz bandwidth is reduced by 22 dB relative to that measured in the entire bandwidth; this reduction corresponds to a peak-to-peak deviation of 600 kHz.

ANNEX 7 (REV.WRC-19)

**Orbital position limitations**<sup>55, 56</sup>

A In applying the procedure of Article 4 for proposed modifications to the Region 2 Plan or for proposed new or modified assignments in the Regions 1 and 3 List, administrations should observe the following criteria:

- 1) No broadcasting satellite serving an area in Region 1 and using a frequency in the frequency band 11.7-12.2 GHz shall occupy a nominal orbital position further east than 146° E.
- 2) No broadcasting satellite serving an area in Region 2 and using a frequency in the frequency band 12.2-12.7 GHz that involves an orbital position different from that contained in the Region 2 Plan shall occupy a nominal orbital position further west than 175.2° W.

However, modifications necessary to resolve possible incompatibilities during the incorporation of the Regions 1 and 3 feeder-link Plan into the Radio Regulations shall be permitted.

- 3) (SUP WRC-19)

B The Region 2 Plan is based on the grouping of the space stations in nominal orbital positions of  $\pm 0.2^\circ$  from the centre of the cluster of satellites. Administrations may locate those satellites within a cluster at any orbital position within that cluster, provided they obtain the agreement of administrations having assignments to space stations in the same cluster. (See § 4.13.1 of Annex 3 to Appendix 30A.)

---

<sup>55</sup> See Resolution 558 (WRC-19). (WRC-19)

<sup>56</sup> Resolution 768 (WRC-19) applies to broadcasting satellites serving areas in Region 1 in the frequency band 11.7-12.2 GHz from nominal orbital positions further west than 37.2° W and broadcasting satellites serving areas in Region 2 in the frequency band 12.5-12.7 GHz from nominal orbital positions further east than 54° W and not within its clusters in the Region 2 Plan of Appendix 30. (WRC-19)

## APPENDIX 30A (REV.WRC-19)\*

**Provisions and associated Plans and List<sup>1</sup> for feeder links for the broadcasting-satellite service (11.7-12.5 GHz in Region 1, 12.2-12.7 GHz in Region 2 and 11.7-12.2 GHz in Region 3) in the frequency bands 14.5-14.8 GHz<sup>2</sup> and 17.3-18.1 GHz in Regions 1 and 3, and 17.3-17.8 GHz in Region 2** (WRC-03)

(See Articles 9 and 11) (WRC-03)

## TABLE OF CONTENTS

		<i>Page</i>
Article 1	General definitions .....	3
Article 2	Frequency bands.....	4
Article 2A	Use of the guardbands .....	4
Article 3	Execution of the provisions and associated Plans .....	5
Article 4	Procedures for modifications to the Region 2 feeder-link Plan or for additional uses in Regions 1 and 3 .....	6
Article 5	Coordination, notification, examination and recording in the Master International Frequency Register of frequency assignments to feeder-link transmitting earth stations and receiving space stations in the fixed-satellite service.....	19
Article 6	Coordination, notification and recording in the Master International Frequency Register of frequency assignments to receiving terrestrial stations in Regions 1 and 3 in the bands 14.5-14.8 GHz and 17.7-18.1 GHz, and in Region 2 in the band 17.7-17.8 GHz, when frequency assignments to feeder-link transmitting earth stations for the broadcasting-satellite service in conformity with the Regions 1 and 3 feeder-link Plan or the Region 2 feeder-link Plan are involved.....	25

\* The expression “frequency assignment to a space station”, wherever it appears in this Appendix, shall be understood to refer to a frequency assignment associated with a given orbital position. (WRC-03)

<sup>1</sup> The Regions 1 and 3 feeder-link List of additional uses is annexed to the Master International Frequency Register (see Resolution **542 (WRC-2000)**\*\*). (WRC-03)

\*\* *Note by the Secretariat:* This Resolution was abrogated by WRC-03.

<sup>2</sup> This use of the band 14.5-14.8 GHz is reserved for countries outside Europe.

*Note by the Secretariat:* Reference to an Article with the number in roman is referring to an Article in this Appendix.



Article 7	Coordination, notification and recording in the Master International Frequency Register of frequency assignments to stations in the fixed-satellite service (space-to-Earth) in Region 1 in the frequency band 17.3-18.1 GHz and in Regions 2 and 3 in the frequency band 17.7-18.1 GHz, to stations in the fixed-satellite service (Earth-to-space) in Region 2 in the frequency bands 14.5-14.8 GHz and 17.8-18.1 GHz, to stations in the fixed-satellite service (Earth-to-space) in countries listed in Resolution 163 (WRC-15) in the frequency band 14.5-14.75 GHz and in countries listed in Resolution 164 (WRC-15) in the frequency band 14.5-14.8 GHz where those stations are not for feeder links for the broadcasting-satellite service, and to stations in the broadcasting-satellite service in Region 2 in the frequency band 17.3-17.8 GHz when frequency assignments to feeder links for broadcasting-satellite stations in the frequency bands 14.5-14.8 GHz and 17.3-18.1 GHz in Regions 1 and 3 or in the frequency band 17.3-17.8 GHz in Region 2 are involved.....	26
Article 8	Miscellaneous provisions relating to the procedures .....	29
Article 9	Plan for feeder links for the broadcasting-satellite service in the fixed-satellite service in the frequency band 17.3-17.8 GHz in Region 2 .....	30
Article 9A	Plan for feeder links for the broadcasting-satellite service in the fixed-satellite service in the frequency bands 14.5-14.8 GHz and 17.3-18.1 GHz in Regions 1 and 3 .....	66
Article 10	Interference.....	93
Article 11	Period of validity of the provisions and associated Plans .....	93
ANNEXES		
Annex 1	Limits for determining whether a service of an administration is considered to be affected by a proposed modification to the Region 2 feeder-link Plan or by a proposed new or modified assignment in the Regions 1 and 3 feeder-link List or when it is necessary under this Appendix to seek the agreement of any other administration.....	93
Annex 2	Basic characteristics to be furnished in notices relating to feeder-link stations in the fixed-satellite service operating in the frequency bands 14.5-14.8 GHz and 17.3-18.1 GHz .....	96
Annex 3	Technical data used in establishing the provisions and associated Plans and Regions 1 and 3 feeder-link List, which should be used for their application.....	96
Annex 4	Criteria for sharing between services .....	135

## ARTICLE 1 (REV.WRC-03)

**General definitions**

1 For the purposes of this Appendix, the following terms shall have the meanings defined below:

1.1 *Regions 1 and 3 feeder-link Plan*: The Plan for feeder links in the frequency bands 14.5-14.8 GHz<sup>3</sup> and 17.3-18.1 GHz for the broadcasting-satellite service in Regions 1 and 3 contained in this Appendix.

1.2 *Region 2 feeder-link Plan*: The Plan for feeder links in the frequency band 17.3-17.8 GHz for the broadcasting-satellite service in Region 2 contained in this Appendix, together with any modifications resulting from the successful application of the procedure of Article 4.

1.3 *Frequency assignment in conformity with the Plan*:

- any frequency assignment for a receiving space station or transmitting earth station which appears in the Regions 1 and 3 feeder-link Plan; *or*
- any frequency assignment for a receiving space station or transmitting earth station which appears in the Region 2 feeder-link Plan or for which the procedure of Article 4 has been successfully applied.

1.4 *1983 Conference*: Regional Administrative Radio Conference for the Planning in Region 2 of the Broadcasting-Satellite Service in the Frequency Band 12.2-12.7 GHz and Associated Feeder-links in the Frequency Band 17.3-17.8 GHz, called in short Regional Administrative Conference for the Planning of the Broadcasting-Satellite Service in Region 2 (Geneva, 1983) (RARC Sat-R2).

1.5 *1985 Conference*: First Session of the World Administrative Radio Conference on the Use of the Geostationary-Satellite Orbit and the Planning of Space Services Utilizing It (Geneva, 1985), called in short WARC Orb-85.

1.6 *1988 Conference*: Second Session of the World Administrative Radio Conference on the Use of the Geostationary-Satellite Orbit and the Planning of Space Services Utilizing It (Geneva, 1988), called in short WARC Orb-88.

1.7 *1997 Conference*: World Radiocommunication Conference (Geneva, 1997), called in short WRC-97.

1.8 *2000 Conference*: World Radiocommunication Conference (Istanbul, 2000), called in short WRC-2000.

---

<sup>3</sup> This use of the band 14.5-14.8 GHz is reserved for countries outside Europe.

## AP30A-4

1.9 *Additional use in Regions 1 and 3:* For the application of the provisions of this Appendix, additional uses in Regions 1 and 3 are:

- a) use of assignments with characteristics different from those appearing in the Regions 1 and 3 feeder-link Plan and which are capable of causing more interference than the corresponding entries in that Plan;
- b) use of assignments in addition to those appearing in the Regions 1 and 3 feeder-link Plan.

1.10 *Regions 1 and 3 feeder-link List of additional uses (hereafter called in short the “feeder-link List”):* The list of assignments for additional uses in Regions 1 and 3 as established by WRC-2000 (see Resolution **542 (WRC-2000)**\*), as updated following the successful application of the procedure of § 4.1 of Article 4. (WRC-03)

1.11 *Frequency assignment in conformity with the feeder-link List:* Any frequency assignment which appears in the feeder-link List as updated following successful application of § 4.1 of Article 4. (WRC-03)

1.12 *Broadcasting-satellite service (BSS) feeder link subject to one of the Plans:* The BSS feeder-link subject to one of the Plans referred to in this Appendix is the BSS feeder link in the frequency bands 14.5-14.8 GHz and 17.3-18.1 GHz in Regions 1 and 3 and 17.3-17.8 GHz in Region 2. (WRC-03)

## ARTICLE 2 (WRC-03)

### Frequency bands

2.1 The provisions of this Appendix apply to the feeder-links in the fixed-satellite service (Earth-to-space) in the frequency bands 14.5-14.8 GHz and 17.3-18.1 GHz for the broadcasting-satellite service in Regions 1 and 3, and 17.3-17.8 GHz for the broadcasting-satellite service in Region 2 and to other services to which these bands are allocated in Regions 1, 2 and 3 so far as their relationship to the fixed-satellite service (Earth-to-space) in these bands is concerned.

2.2 (SUP - WRC-03)

## ARTICLE 2A (REV.WRC-19)

### Use of the guardbands<sup>3bis</sup>

2A.1 The use of the guardbands defined in § 3.1 and 4.1 of Annex 3 to provide space operation functions in accordance with No. **1.23** in support of the operation of geostationary-satellite networks for the broadcasting-satellite service (BSS) feeder link is not subject to the application of Section I of Article 9.

---

\* *Note by the Secretariat:* This Resolution was abrogated by WRC-03.

<sup>3bis</sup> The provisions of Resolution **49 (Rev.WRC-19)** do not apply. (WRC-19)

2A.1.1 Coordination between assignments intended to provide the space operation functions and assignments of the BSS feeder link subject to a Plan shall be effected using the provisions of Article 7.

2A.1.2 Coordination among assignments intended to provide the space operation functions and services not subject to a Plan shall be effected using the provisions of Nos. 9.7, 9.17, 9.17A, 9.18, and the associated provisions of Section II of Article 9, as appropriate.

2A.1.3 Coordination of modifications to the Region 2 feeder-link Plan or assignments to be included in the Regions 1 and 3 feeder-link List, with assignments intended to provide these functions shall be effected using § 4.1.1 *d*) of Article 4.

2A.1.4 Requests for the coordination referred to in § 2A.1.1, 2A.1.2 and 2A.1.3 shall be sent by the requesting administration to the Bureau, together with the appropriate information listed in Appendix 4.

2A.2 Any assignment intended to provide these functions in support of a geostationary-satellite network for the BSS feeder link shall be notified under Article 11 and brought into use within the following time-limits<sup>3<sup>ter</sup></sup>. (WRC-15)

2A.2.1 *a*) for the case where the associated BSS feeder-link assignments are contained in one of the initial Plans (Region 2 Plans incorporated in the Radio Regulations at WARC Orb-85 and Regions 1 and 3 Plan adopted at WRC-2000), within the regulatory time-limit referred to in § 4.1.3 or 4.2.6 of Article 4 from the date of receipt by the Bureau of the complete Appendix 4 data for those assignments intended to provide the space operation functions;

2A.2.2 *b*) for the case where the associated BSS feeder-link assignments have been submitted under § 4.1.3 or § 4.2.6 of Article 4 for entry in the Regions 1 and 3 List or a modification to the Region 2 Plan, within the regulatory time-limit referred to in § 4.1.3 or § 4.2.6 of Article 4 for those associated BSS feeder-link assignments;

2A.2.3 *c*) for the case where the associated BSS feeder-link assignments have already been brought into use in accordance with the Radio Regulations, within the regulatory time-limit referred to in § 4.1.3 and § 4.2.6 of Article 4 from the date of receipt by the Bureau of the complete Appendix 4 data for those assignments intended to provide these space operation functions.

## ARTICLE 3 (REV.WRC-19)

### Execution of the provisions and associated Plans

3.1 The Member States in Regions 1, 2 and 3 shall adopt, for their feeder-link space and earth stations in the fixed-satellite service (Earth-to-space) in the frequency bands referred to in this Appendix, the characteristics specified in the appropriate Regional Plan and the associated provisions.

---

<sup>3<sup>ter</sup></sup> The time-limit is established at the time when the request is received under § 2A.1.4. (WRC-15)

3.2 The Member States shall not change the characteristics specified in the Region 1 and 3 feeder-link Plan or in the Region 2 feeder-link Plan, or bring into use assignments to receiving space stations or transmitting earth stations in the fixed-satellite service or to stations of the other services to which these frequency bands are allocated, except as provided for in the Radio Regulations and the appropriate Articles and Annexes of this Appendix.

3.3 The procedures for the use of interim systems in Region 2 for feeder links in the fixed-satellite service for the frequency bands covered by this Appendix are given in Resolution **42 (Rev.WRC-19)**. (WRC-19)

3.4 The Regions 1 and 3 feeder-link Plan is based on national coverage from the geostationary-satellite orbit. The associated procedures contained in this Appendix are intended to promote long-term flexibility of the Plan and to avoid monopolization of the planned bands and orbit by a country or a group of countries.

## ARTICLE 4 (REV.WRC-19)

### **Procedures for modifications to the Region 2 feeder-link Plan or for additional uses in Regions 1 and 3**

#### **4.1 Provisions applicable to Regions 1 and 3**

4.1.1 An administration proposing to include a new or modified assignment in the feeder-link List shall seek the agreement of those administrations whose services are considered to be affected, i.e. administrations<sup>4, 5</sup>:

- a) of Regions 1 and 3 having a feeder-link frequency assignment in the fixed-satellite service (Earth-to-space) to a space station in the broadcasting-satellite service which is included in the Regions 1 and 3 feeder-link Plan with a necessary bandwidth, any portion of which falls within the necessary bandwidth of the proposed assignment; *or*
- b) of Regions 1 and 3 having a feeder-link frequency assignment included in the feeder-link List or for which complete Appendix 4 information has been received by the Radiocommunication Bureau in accordance with the provisions of § 4.1.3, and any portion of which falls within the necessary bandwidth of the proposed assignment; *or*

---

<sup>4</sup> Agreement with administrations having a frequency assignment in the bands 14.5-14.8 GHz or 17.7-18.1 GHz to a terrestrial station, or having a frequency assignment in the band 17.7-18.1 GHz to an earth station in the fixed-satellite service (space-to-Earth), or having a frequency assignment in the band 17.3-17.8 GHz in the broadcasting-satellite service shall be sought under No. **9.17**, No. **9.17A** or No. **9.19**, respectively.

<sup>5</sup> Coordination under Nos. **9.17** or **9.17A** is not required for an earth station of an administration on the territory of which this earth station is located and for which the procedures of former § 4.2.1.2 and 4.2.1.3 of Appendix **30A (WRC-97)** have been successfully applied by that administration before 3 June 2000 in respect of terrestrial stations or earth stations operating in the opposite direction of transmission. (WRC-03)

- c) of Region 2 having a feeder-link frequency assignment in the fixed-satellite service (Earth-to-space) to a space station in the broadcasting-satellite service which is in conformity with the Region 2 feeder-link Plan, or in respect of which proposed modifications to that Plan have already been received by the Bureau in accordance with the provisions of § 4.2.6 with a necessary bandwidth, any portion of which falls within the necessary bandwidth of the proposed assignment; *or*
- d) having a feeder-link frequency assignment in the frequency bands 14.5-14.8 GHz or 17.8-18.1 GHz in Region 2 in the fixed-satellite service (Earth-to-space) to a space station in the broadcasting-satellite service, or a frequency assignment in the frequency band 14.5-14.75 GHz in countries listed in Resolution **163 (WRC-15)** and in the frequency band 14.5-14.8 GHz in countries listed in Resolution **164 (WRC-15)**, in the fixed-satellite service (Earth-to-space) not subject to a Plan, which is recorded in the Master Register or which has been coordinated or is being coordinated under the provisions of No. **9.7**, or under § 7.1 of Article **7**, with a necessary bandwidth, any portion of which falls within the necessary bandwidth of the proposed assignment. (WRC-19)

4.1.2 The services of an administration are considered to be affected when the limits shown in Annex 1 are exceeded.

4.1.3 An administration, or one<sup>6</sup> acting on behalf of a group of named administrations, intending to include a new or modified assignment in the feeder-link List shall send to the Bureau, not earlier than eight years but preferably not later than two years before the date on which the assignment is to be brought into use, the relevant information listed in Appendix 4. An assignment in the feeder-link List shall lapse if it is not brought into use within eight years after the date of receipt by the Bureau of the relevant complete information. A proposed new or modified assignment not included in the List within eight years after the date of receipt by the Bureau of the relevant complete information<sup>7</sup> shall also lapse. (WRC-19)

4.1.3*bis* The regulatory time-limit for bringing into use an assignment in the List may be extended once by not more than three years due to launch failure in the following cases:

- the destruction of the satellite intended to bring the assignment into use; *or*
- the destruction of the satellite launched to replace an already operating satellite which is intended to be relocated to bring another assignment into use; *or*
- the satellite is launched, but fails to reach its assigned orbital location.

<sup>6</sup> Whenever, under this provision, an administration acts on behalf of a group of named administrations, all members of that group retain the right to respond in respect of their own networks or systems. (WRC-03)

<sup>7</sup> The provisions of Resolution **533 (Rev.WRC-2000)**\* apply. (WRC-03)

\* *Note by the Secretariat:* This Resolution was abrogated by WRC-12.

For this extension to be granted, the launch failure must have occurred at least five years after the date of receipt of the complete Appendix 4 data. In no case shall the period of the extension of the regulatory time-limit exceed the difference in time between the three-year period and the period remaining from the date of the launch failure to the end of the regulatory time-limit<sup>8</sup>. In order to take advantage of this extension, the administration shall have, within one month of the launch failure or one month after 5 July 2003, whichever comes later, notified the Bureau in writing of such failure, and shall also provide the following information to the Bureau before the end of the regulatory time-limit of § 4.1.3:

- date of launch failure;
- due diligence information as required in Resolution 49 (Rev.WRC-15) for the assignment with respect to the satellite that suffered the launch failure, if that information has not already been provided.

If, 11 months after the request for extension, the administration has not provided to the Bureau updated Resolution 49 (Rev.WRC-15) information, the Bureau shall promptly send a reminder to the notifying administration. If, within one year of the request for extension, the administration has not provided to the Bureau updated Resolution 49 (Rev.WRC-15) information for the new satellite under procurement, the related frequency assignments shall lapse. (WRC-15)

4.1.4 If the information received by the Bureau under § 4.1.3 is found to be incomplete, the Bureau shall immediately seek from the administration concerned any clarification required and information not provided.

4.1.5 The Bureau shall determine, on the basis of Annex 1, the administrations whose frequency assignments are considered to be affected. The Bureau shall publish<sup>9</sup>, in a Special Section of its International Frequency Information Circular (BR IFIC), the complete information received under § 4.1.3, together with the names of the affected administrations, the corresponding fixed-satellite service networks, and the corresponding feeder-links to broadcasting-satellite service assignments, as appropriate. The Bureau shall immediately send a telegram/fax to the administration proposing the assignment, drawing its attention to the information contained in the relevant BR IFIC. (WRC-07)

4.1.6 The Bureau shall send a telegram/fax to the administrations listed in the Special Section of the BR IFIC, drawing their attention to the information it contains. (WRC-07)

4.1.7 An administration which considers that it should have been identified in the publication referred to under § 4.1.5 above shall, within four months of the date of publication of its relevant BR IFIC, and giving the technical reasons for so doing, request the Bureau to include its name in the publication. The Bureau shall study this information on the basis of Annex 1 and shall inform both administrations of its conclusions. Should the Bureau agree to the administration's request, it shall publish an addendum to the publication under § 4.1.5.

---

<sup>8</sup> For a launch failure which occurred before 5 July 2003, the maximum extension of three years shall apply as from 5 July 2003. (WRC-03)

<sup>9</sup> If the payments are not received in accordance with the provisions of Council Decision 482, as amended, on the implementation of cost recovery for satellite network filings, the Bureau shall cancel the publication, after informing the administration concerned. The Bureau shall inform all administrations of such action and that the network specified in the publication in question no longer has to be taken into consideration by the Bureau and other administrations. The Bureau shall send a reminder to the notifying administration not later than two months prior to the deadline for the payment in accordance with the above-mentioned Council Decision 482 unless the payment has already been received. (WRC-07)

4.1.7*bis* Except as provided under § 4.1.18 to 4.1.20, any inclusion of a new or modified frequency assignment in the Regions 1 and 3 List which would have the effect of exceeding the limits specified in Annex 1 shall be subject to the agreement of all administrations whose services are considered to be affected. (WRC-03)

4.1.8 The administration seeking agreement or the administration with which agreement is sought may request any additional technical information it considers necessary. The administrations shall inform the Bureau of such requests.

4.1.9 Comments from administrations identified in the publication referred to under § 4.1.5 above shall be sent to the Bureau and to the administration proposing the modification. (WRC-15)

4.1.10 An administration that has not notified its agreement either to the administration seeking agreement or to the Bureau within a period of four months following the date of the BR IFIC referred to in § 4.1.5 shall be deemed to have not agreed to the proposed assignment unless the provisions of § 4.1.10a to 4.1.10d and § 4.1.21 are applied. This time-limit may be extended:

- for an administration that has requested additional information under § 4.1.8, by up to three months, *or*
- for an administration that has requested the assistance of the Bureau under § 4.1.21, by up to three months following the date at which the Bureau communicated the result of its action. (WRC-15)

4.1.10*bis* Thirty days prior to the expiry of the same four-month period, the Bureau shall dispatch a reminder telegram or fax to an administration which has not made its comments under § 4.1.10, bringing the matter to its attention. (WRC-03)

4.1.10*ter* (SUP - WRC-15)

4.1.10a After the same time period as specified in § 4.1.10, the notifying administration may, pursuant to § 4.1.21, request the Bureau to assist in respect of an administration which has not replied within this time period. (WRC-15)

4.1.10b The Bureau, acting under § 4.1.10a, shall send a reminder to the administration which has not replied, together with the results of its previously published compatibility analysis, containing the change in the values referred to in paragraph 4 of Annex 1 to Appendix **30A**, requesting a decision. (WRC-15)

4.1.10c Fifteen days before the expiry of the 30-day period referred to in § 4.1.10d, the Bureau shall send a reminder to the above-mentioned administration drawing its attention to the consequence of no reply. (WRC-15)

4.1.10d If no decision is communicated to the Bureau within 30 days after the date of dispatch of the reminder under § 4.1.10b, it shall be deemed that the administration which has not given a decision has agreed to the proposed assignment. (WRC-15)

4.1.11 If, in seeking agreement, an administration modifies its initial proposal, it shall again apply the provisions of § 4.1 and the subsequent procedure in cases where:

- the assignments of any other administration received by the Bureau in accordance with § 4.1.3 or § 4.2.6, or § 2A.1.4 of Article 2A, or § 7.1 of Article 7, or No. **9.7** before this modified proposal is received under § 4.1.12; *or*
- the assignments of any other administration contained in the Plans or the Lists,

are considered as being affected and receive more interference as a result of the modifications than that produced by the initial proposal. (WRC-15)



4.1.12<sup>9bis</sup> If agreement has been reached with the administrations identified in the publication referred to under § 4.1.5 above, the administration proposing the new or modified assignment may continue with the appropriate procedure in Article 5 and shall inform the Bureau, indicating the final characteristics of the frequency assignment together with the names of the administrations with which agreement has been reached. (WRC-19)

4.1.12<sup>bis</sup> In application of § 4.1.12, an administration may indicate the changes to the information communicated to the Bureau under § 4.1.3 and published under § 4.1.5. In submitting such information, noting the requirements of § 5.1.6, the administration may also request the Bureau to examine the submission in respect of notification under § 5.1.2. (WRC-19)

4.1.13 The agreement of the administrations affected may also be obtained in accordance with this Article, for a specified period. When this specific period of agreement expires for an assignment in the List, the assignment in question shall be maintained in the List until the end of the period referred to in § 4.1.3 above. After that date this assignment shall lapse unless the agreement of the administrations affected is renewed<sup>9ter</sup>. (WRC-19)

4.1.14 Where the proposed assignment involves developing countries, administrations shall seek all practicable solutions conducive to the economical development of the broadcasting-satellite systems of these countries.

4.1.15 The Bureau shall publish<sup>10</sup> in a Special Section of its BR IFIC the information received under § 4.1.12, together with the names of any administrations with which the provisions of this Article have been successfully applied. The frequency assignment concerned shall be included in the feeder-link List. (WRC-03)

4.1.16 In case of disagreement on the part of an administration whose agreement has been sought, the requesting administration shall first endeavour to solve the problem by exploring all possible means of meeting its requirement. If the problem still cannot be solved by such means, the administration whose agreement has been sought should endeavour to overcome the difficulties as far as possible, and shall state the technical reasons for any disagreement if the administration seeking the agreement requests it to do so. (WRC-19)

4.1.17 If no agreement is reached between the administrations concerned, the Bureau shall carry out any study that may be requested by either one of these administrations; the Bureau shall inform them of the result of the study and shall make such recommendations as it may be able to offer for the solution of the problem.

---

<sup>9bis</sup> For any remaining affected networks whose assignments were entered in the List before the notice received under § 4.1.12, the Bureau shall use the method in Annex 1 to further examine if the remaining corresponding assignments in the List are still considered as being affected. The examination in respect of those remaining affected networks is conducted independently using the Appendices 30 and 30A master database corresponding to the Part B Special Section that was published under § 4.1.15. Resolution 548 (Rev.WRC-12) applies. (WRC-19)

<sup>9ter</sup> Unless the Bureau has been informed by the notifying administration of the renewal of the agreement, it shall, no later than six months before the end of the specified period, send a reminder to the notifying administration. (WRC-19)

<sup>10</sup> If the payments are not received in accordance with the provisions of Council Decision 482, as amended, on the implementation of cost recovery for satellite network filings, the Bureau shall cancel the publication, after informing the administration concerned. The Bureau shall inform all administrations of such action and that the network specified in the publication in question no longer has to be taken into consideration by the Bureau and other administrations. The Bureau shall send a reminder to the notifying administration not later than two months prior to the deadline for the payment in accordance with the above-mentioned Council Decision 482 unless the payment has already been received. (WRC-07)

4.1.18 If, in spite of the application of § 4.1.16 and 4.1.17, there is still continuing disagreement and the assignment which was the basis of the disagreement is not an assignment in the Regions 1 and 3 Plan, or in the Region 2 Plan or for which the procedure of § 4.2 has been initiated, and if the notifying administration insists that the proposed assignment be included in the Regions 1 and 3 feeder-link List, the Bureau shall provisionally enter the assignment in the Regions 1 and 3 feeder-link List with an indication of those administrations whose assignments were the basis of the disagreement; however, the entry shall be changed from provisional to definitive recording in the feeder-link List only if the Bureau is informed that the new assignment in the Regions 1 and 3 feeder-link List has been in use, together with the assignment which was the basis for the disagreement, for at least four months without any complaint of harmful interference being made. (WRC-03)

4.1.18*bis* When requesting the application of § 4.1.18, the notifying administration shall undertake to meet the requirements of § 4.1.20 and provide to the administration in respect of which § 4.1.18 is applied, with a copy to the Bureau, a description of the steps by which it undertakes to meet these requirements. Once an assignment is entered in the feeder-link List provisionally under the provisions of § 4.1.18, the calculation of the equivalent protection margin (EPM)<sup>11</sup> of an assignment in the Regions 1 and 3 feeder-link List or for which the procedure of Article 4 has been initiated and which was the basis for the disagreement shall not take into account interference produced by the assignment for which the provisions of § 4.1.18 have been applied. When the recording of an assignment entered into the List is changed from provisional to definitive in accordance with § 4.1.18, but there is still continuing disagreement between the administrations, the Bureau shall consult with the administration responsible for the assignments which were the basis for the disagreement in determining the appropriate course of action as regards any update to the EPM for the assignments which were the basis for the disagreement. (WRC-19)

4.1.19 Should the assignments that were the basis of the disagreement not be brought into use within the period specified in No. 11.44 (for non-planned services), or in § 4.1 (for assignments in the feeder-link List or having initiated the procedure under § 4.1), as appropriate, then the status of the assignment in the feeder-link List shall be reviewed accordingly. (WRC-03)

4.1.20 Should harmful interference be caused by an assignment included in the feeder-link List under § 4.1.18 to any recorded assignment in the Master Register which was the basis of the disagreement, the administration using the frequency assignment included in the feeder-link List under § 4.1.18 shall, upon receipt of advice thereof, immediately eliminate this harmful interference. (WRC-03)

4.1.21 An administration may, at any stage in the procedure described, or before applying it, request the assistance of the Bureau.

4.1.22 The relevant provisions of Article 5 shall be applied when frequency assignments are notified to the Bureau.

4.1.23 When a frequency assignment included in the feeder-link List is no longer required, the administration concerned shall immediately so inform the Bureau. The Bureau shall publish this information in a Special Section of its BR IFIC and delete the assignment from the feeder-link List. (WRC-03)

---

<sup>11</sup> For the definition of the EPM, see § 1.7 of Annex 3. (WRC-03)

4.1.24 No assignment in the feeder-link List shall have a period of operation exceeding 15 years, counted from the date of bringing into use, or 2 June 2000, whichever is later. Upon request by the responsible administration received by the Bureau at the latest three years before the expiry of this period, this period may be extended by up to 15 years, on condition that all the characteristics of the assignment remain unchanged<sup>11bis</sup>. (WRC-19)

4.1.25 Where an administration already having included in the feeder-link List two assignments (not including those systems notified on behalf of a group of named administrations and included in the feeder-link List by WRC-2000) in the same channel and covering the same service area, proposes to include in the feeder-link List a new assignment in the same channel over this same service area, it shall apply the following in respect of another administration which has no assignment in the feeder-link List in the same channel and which proposes to include in the feeder-link List a new assignment:

- a) if the agreement of the former administration is required following the application of § 4.1 by the latter administration, in order to protect the new assignment proposed by the former administration from interference caused by the assignment proposed by the latter administration, both administrations shall make every possible effort to resolve the difficulties by means of mutually acceptable adjustments to their networks;
- b) in case of continuing disagreement, and if the former administration has not communicated to the Bureau the information specified in Annex 2 to Resolution 49 (Rev.WRC-15), this administration shall be deemed to have given its agreement to inclusion in the feeder-link List of the assignment of the latter administration. (WRC-15)

4.1.26 The procedure of this Article may be applied by the administration of a new ITU Member State in order to include new assignments in the feeder-link List. Upon completion of the procedure, the next world radiocommunication conference may be requested to consider, among the assignments included in the feeder-link List after the successful completion of this procedure, the inclusion in the Regions 1 and 3 feeder-link Plan of up to 10 channels (for Region 1) and up to 12 channels (for Region 3), over the national territory of the new Member State. (WRC-03)

4.1.27 When an administration has successfully applied this procedure and received all the agreements<sup>12</sup> required to include in the feeder-link List assignments over its national territory, at an orbital location and/or in channels different from those appearing in the Regions 1 and 3 feeder-link Plan for its country, it may request the next world radiocommunication conference to consider the inclusion in this Plan of up to 10 (for Region 1) and up to 12 (for Region 3) of these assignments, in replacement of its assignments appearing in this Plan. (WRC-03)

4.1.27bis Should the assignments mentioned in § 4.1.26 and 4.1.27 over the national territory of the administration not be brought into use within the regulatory time-limit mentioned in § 4.1.3, they would be retained in the List until the end of the World Radiocommunication Conference following immediately after the successful completion of procedure referred to in § 4.1.26 and 4.1.27, respectively and thereafter they shall be removed from the List. (WRC-03)

---

<sup>11bis</sup> Unless the request has been received by the Bureau, it shall, no later than 90 days before the deadline of such a request, send a reminder to the notifying administration. (WRC-19)

<sup>12</sup> In such a case, § 4.1.18 does not apply.

4.1.28 The feeder-link List, as updated, shall be published periodically by the Bureau. (WRC-03)

4.1.29 New or modified assignments in the feeder-link List shall be limited to digital modulation. (WRC-03)

## 4.2 Provisions applicable to Region 2

4.2.1 When an administration intends to make a modification to the Region 2 feeder-link Plan, i.e.:

- a) to modify the characteristics of any of its frequency assignments in the fixed-satellite service which are shown in the Region 2 feeder-link Plan, or for which the procedure in this Article has been successfully applied, whether or not the station has been brought into use; *or*
- b) to include in the Region 2 feeder-link Plan a new frequency assignment in the fixed-satellite service; *or*
- c) to cancel a frequency assignment in the fixed-satellite service,

the following procedure shall be applied before any notification of the frequency assignment is made to the Bureau (see Article 5 and Resolution **42 (Rev.WRC-19)**). (WRC-19)

4.2.2 An administration proposing a modification to the characteristics of a frequency assignment in conformity with the Region 2 feeder-link Plan, or the inclusion of a new frequency assignment in that Plan, shall seek the agreement of those administrations<sup>13, 14, 15</sup>:

- a) having an assignment for feeder-links in the fixed-satellite service (Earth-to-space) which is in conformity with the Regions 1 and 3 feeder-link Plan with the necessary bandwidth, any portion of which falls within the necessary bandwidth of the proposed assignment; *or*
- b) of Regions 1 and 3 having a feeder-link frequency assignment included in the feeder-link List or for which complete Appendix 4 information has been received by the Bureau in accordance with the provisions of § 4.1.3, and any portion of which falls within the necessary bandwidth of the proposed assignment; *or*
- c) of Region 2 having a feeder-link frequency assignment in the fixed-satellite service (Earth-to-space) in the same channel or an adjacent channel, which appears in the Region 2 feeder-link Plan or in respect of which proposed modifications to this Plan have been received by the Bureau in accordance with the provisions of § 4.2.6;
- d) which are considered affected. (WRC-03)

<sup>13</sup> Agreement with administrations having a frequency assignment in the bands 17.7-17.8 GHz to a terrestrial station or to an earth station in the fixed-satellite service (space-to-Earth) shall be sought under No. **9.17** or No. **9.17A**, respectively.

<sup>14</sup> Coordination under No. **9.17** or **9.17A** is not required for an earth station of an administration on the territory of which this earth station is located and for which the procedures of former § 4.2.3.2 and 4.2.3.3 of Appendix **30A (WRC-97)** have been successfully applied by that administration before 3 June 2000 in respect of terrestrial stations or earth stations operating in the opposite direction of transmission. (WRC-03)

<sup>15</sup> Agreement with administrations having a frequency assignment in the band 17.3-17.8 GHz to an earth station in the broadcasting-satellite service shall be sought under No. **9.19**.

4.2.3 (Not used.)

4.2.4 The services of an administration are considered to be affected when the limits shown in Annex 1 are exceeded.

4.2.5 The agreement referred to in § 4.2.2 is not required when an administration proposes to bring into use, with characteristics appearing in the Region 2 feeder-link Plan, a fixed feeder-link earth station in the band 17.3-17.8 GHz or a transportable feeder-link earth station in the band 17.3-17.7 GHz. Administrations may communicate to the Bureau the characteristics of such earth stations for inclusion in this Plan.

4.2.6 An administration, or one<sup>16</sup> acting on behalf of a group of named administrations, intending to make a modification to the Region 2 feeder-link Plan shall send to the Bureau, not earlier than eight years but preferably not later than two years before the date on which the assignment is to be brought into use, the relevant information listed in Appendix 4. Modifications to that Plan shall lapse if the assignment is not brought into use within eight years after the date of receipt by the Bureau of the relevant complete information<sup>17</sup>. A request for a modification that has not been included in that Plan within eight years after the date of receipt by the Bureau of the relevant complete information<sup>17</sup> shall also lapse. (WRC-07)

4.2.6bis The regulatory time-limit for bringing into use of an assignment in the Region 2 Plan obtained through application of § 4.2 may be extended once by no more than three years due to launch failure in the following cases:

- the destruction of the satellite intended to bring the assignment into use; *or*
- the destruction of the satellite launched to replace an already operating satellite which is intended to be relocated to bring another assignment into use; *or*
- the satellite is launched, but fails to reach its assigned orbital location.

For this extension to be granted, the launch failure must have occurred at least five years after the date of receipt of the complete Appendix 4 data. In no case shall the period of the extension of the regulatory time-limit exceed the difference in time between the three-year period and the period remaining from the date of the launch failure to the end of the regulatory time-limit<sup>18</sup>. In order to take advantage of this extension, the administration shall have, within one month of the launch failure or one month after 5 July 2003, whichever comes later, notified the Bureau in writing of such failure, and shall also provide the following information to the Bureau before the end of the regulatory time-limit of § 4.2.6:

- date of launch failure;
- due diligence information as required in Resolution 49 (Rev.WRC-15) for the assignment with respect to the satellite that suffered the launch failure, if that information has not already been provided.

---

<sup>16</sup> Whenever, under this provision, an administration acts on behalf of a group of named administrations, all members of that group retain the right to respond in respect of their own networks or systems. (WRC-03)

<sup>17</sup> The provisions of Resolution 533 (Rev.WRC-2000)\* apply. (WRC-03)

\* *Note by the Secretariat:* This Resolution was abrogated by WRC-12.

<sup>18</sup> For a launch failure which occurred before 5 July 2003, the maximum extension of three years shall apply as from 5 July 2003. (WRC-03)

If, 11 months after the request for extension, the administration has not provided to the Bureau updated Resolution 49 (Rev.WRC-15) information, the Bureau shall promptly send a reminder to the notifying administration. If, within one year of the request for extension, the administration has not provided to the Bureau updated Resolution 49 (Rev.WRC-15) information for the new satellite under procurement, the related frequency assignments shall lapse. (WRC-15)

4.2.7 If the information received by the Bureau under § 4.2.6 is found to be incomplete, the Bureau shall immediately seek from the administration concerned any clarification required and information not provided.

4.2.8 The Bureau shall determine, on the basis of Annex 1, the administrations whose frequency assignments are considered to be affected within the meaning of § 4.2.2. The Bureau shall publish<sup>19</sup>, in a Special Section of its BR IFIC, the complete information received under § 4.2.6, together with the names of the affected administrations, the corresponding fixed-satellite service networks, and the corresponding feeder links to broadcasting-satellite service assignments, as appropriate. The Bureau shall immediately send a telegram/fax to the administration proposing the modification to the Region 2 feeder-link Plan, drawing its attention to the information contained in the relevant BR IFIC. (WRC-07)

4.2.9 The Bureau shall send a telegram/fax to the administrations listed in the Special Section of its BR IFIC, drawing their attention to the information it contains. (WRC-07)

4.2.10 An administration which considers that it should have been included in the publication referred to under § 4.2.8 above shall, within four months of the date of publication in the relevant BR IFIC, and giving the technical reasons for so doing, request the Bureau to include its name in the publication. The Bureau shall study this information on the basis of Annex 1 and shall inform both administrations of its conclusions. Should the Bureau agree to the administration's request, it shall publish an addendum to the publication under § 4.2.8. (WRC-07)

4.2.11 Except as provided under § 4.2.21A to 4.2.21D, any modification to a frequency assignment which is in conformity with the Region 2 feeder-link Plan or any inclusion in that Plan of a new frequency assignment which would have the effect of exceeding the limits specified in Annex 1 shall be subject to the agreement of all affected administrations. (WRC-03)

4.2.12 The administration seeking agreement or the administration with which agreement is sought may request any additional technical information it considers necessary. The administrations shall inform the Bureau of such requests.

4.2.13 Comments from administrations on the information published pursuant to § 4.2.8 should be sent either directly to the administration proposing the modification or through the Bureau. In any event, the Bureau shall be informed that comments have been made.

---

<sup>19</sup> If the payments are not received in accordance with the provisions of Council Decision 482, as amended, on the implementation of cost recovery for satellite network filings, the Bureau shall cancel the publication, after informing the administration concerned. The Bureau shall inform all administrations of such action and that the network specified in the publication in question no longer has to be taken into consideration by the Bureau and other administrations. The Bureau shall send a reminder to the notifying administration not later than two months prior to the deadline for the payment in accordance with the above-mentioned Council Decision 482 unless the payment has already been received. (WRC-07)

4.2.14 An administration which has not notified its comments either to the administration seeking agreement or to the Bureau within a period of four months following the date of the BR IFIC referred to in § 4.2.8 shall be deemed to have agreed to the proposed modification. This time-limit may be extended by up to three months for an administration which has requested additional information under § 4.2.12 or for an administration which has requested the assistance of the Bureau under § 4.2.22. In the latter case, the Bureau shall inform the administrations concerned of this request.

4.2.14*bis* Thirty days prior to the expiry of the same four-month period the Bureau shall dispatch a reminder telegram or fax to an administration which has not made its comments under § 4.2.14, bringing the matter to its attention. (WRC-03)

4.2.14*ter* After expiry of the deadline for comments in respect of the proposed assignment, the Bureau shall, according to its records, publish a Special Section, indicating the list of administrations whose agreements are required for completion of the procedure of Article 4. (WRC-03)

4.2.15 If, in seeking agreement, an administration modifies its initial proposal, it shall again apply the provisions of § 4.2 and the consequent procedure with respect to any other administration whose services might be affected as a result of modifications to the initial proposal.

4.2.16<sup>19*bis*</sup> If no comments have been received on the expiry of the periods specified in § 4.2.14, or if agreement has been reached with the administrations which have made comments and with which agreement is necessary, the administration proposing the modification may continue with the appropriate procedure in Article 5, and shall so inform the Bureau, indicating the final characteristics of the frequency assignment together with the names of the administrations with which agreement has been reached. (WRC-19)

4.2.16*bis* In application of § 4.2.16, an administration may indicate the changes to the information communicated to the Bureau under § 4.2.6 and published under § 4.2.8. In submitting such information, noting the requirements of § 5.1.6, the administration may also request the Bureau to examine the submission in respect of notification under § 5.1.2. (WRC-19)

4.2.17 The agreement of the administrations affected may also be obtained in accordance with this Article, for a specified period. When this specific period of agreement expires for an assignment in the Plan, the assignment in question shall be maintained in the Plan until the end of the period referred to in § 4.2.6 above. After that date this assignment in the Plan shall lapse unless the agreement of the administrations affected is renewed<sup>19*ter*</sup>. (WRC-19)

---

<sup>19*bis*</sup> For any remaining affected networks whose assignments were entered in the Plan before the notice received under § 4.2.16, the Bureau shall use the method in Annex 1 to further examine if the remaining corresponding assignments in the Plan are still considered as being affected. The examination in respect of those remaining affected networks is conducted independently using the Appendices 30 and 30A master database corresponding to the Part B Special Section that was published under § 4.2.19. (WRC-19)

<sup>19*ter*</sup> Unless the Bureau has been informed by the notifying administration of the renewal of the agreement, it shall, no later than six months before the end of the specified period, send a reminder to the notifying administration. (WRC-19)

4.2.18 When the proposed modification to the Region 2 feeder-link Plan involves developing countries, administrations shall seek all practicable solutions conducive to the economical development of the broadcasting-satellite systems of these countries.

4.2.19 The Bureau shall publish<sup>20</sup> in a Special Section of its BR IFIC the information received under § 4.2.16 together with the names of any administrations with which the provisions of this Article have been successfully applied. The frequency assignment concerned shall enjoy the same status as those appearing in the Region 2 feeder-link Plan and will be considered as a frequency assignment in conformity with that Plan. (WRC-03)

4.2.20 When an administration proposing to modify the characteristics of a frequency assignment or to make a new frequency assignment receives notice of disagreement on the part of an administration whose agreement it has sought, it shall first endeavour to solve the problem by exploring all possible means of meeting its requirement. If the problem still cannot be solved by such means, the administration whose agreement has been sought should endeavour to overcome the difficulties as far as possible, and shall state the technical reasons for any disagreement if the administration seeking the agreement requests it to do so. (WRC-19)

4.2.21 If no agreement is reached between the administrations concerned, the Bureau shall carry out any study that may be requested by these administrations; the Bureau shall inform them of the result of the study and shall make such recommendations as it may be able to offer for the solution of the problem.

4.2.21A If, in spite of the application of § 4.2.20 and 4.2.21, there is still continuing disagreement and the assignment which was the basis of the disagreement is not an assignment in the Region 2 feeder-link Plan, or in the Regions 1 and 3 feeder-link Plan or List, or for which the procedure of § 4.1 or 4.2 has been initiated, and if the notifying administration insists that the proposed assignment be included in the Region 2 feeder-link Plan, the Bureau shall provisionally enter the assignment in the Region 2 feeder-link Plan with an indication of those administrations whose assignments were the basis of the disagreement; however, the entry shall be changed from provisional to definitive recording in the Region 2 feeder-link Plan only if the Bureau is informed that the new or modified assignment in the Region 2 feeder-link Plan has been in use, together with the assignment which was the basis for the disagreement, for at least four months without any complaint of harmful interference being made. (WRC-03)

4.2.21B When requesting the application of § 4.2.21A, the notifying administration shall undertake to meet the requirements of § 4.2.21D and provide to the administration in respect of which § 4.2.21A has been applied, with a copy to the Bureau, a description of the steps by which it undertakes to meet these requirements. (WRC-03)

---

<sup>20</sup> If the payments are not received in accordance with the provisions of Council Decision 482, as amended, on the implementation of cost recovery for satellite network filings, the Bureau shall cancel the publication, after informing the administration concerned. The Bureau shall inform all administrations of such action and that the network specified in the publication in question no longer has to be taken into consideration by the Bureau and other administrations. The Bureau shall send a reminder to the notifying administration not later than two months prior to the deadline for the payment in accordance with the above-mentioned Council Decision 482 unless the payment has already been received. (WRC-07)



## **AP30A-18**

4.2.21C Should the assignments that were the basis of the disagreement not be brought into use within the period specified in No. **11.44**, the status of the assignment in the Region 2 feeder-link Plan shall be reviewed accordingly. (WRC-03)

4.2.21D Should harmful interference be caused by an assignment included in the Region 2 feeder-link Plan under § 4.2.21A to any recorded assignment in the Master Register which was the basis of the disagreement, the administration using the frequency assignment included in the Region 2 feeder-link Plan under § 4.2.21A shall, upon receipt of advice thereof, immediately eliminate this harmful interference. (WRC-03)

4.2.22 An administration may at any stage in the procedure described, or before applying it, request the assistance of the Bureau.

4.2.23 The relevant provisions of Article 5 shall be applied when frequency assignments are notified to the Bureau.

### **4.2.24 Cancellation of frequency assignments**

When a frequency assignment in conformity with the Region 2 feeder-link Plan is no longer required, whether or not as a result of a modification, the administration concerned shall immediately so inform the Bureau. The Bureau shall publish this information in a Special Section of its BR IFIC and delete the assignment from the Region 2 feeder-link Plan.

### **4.2.25 Master copy of the Region 2 feeder-link Plan**

4.2.25.1 The Bureau shall maintain an up-to-date master copy of the Region 2 feeder-link Plan, including the overall equivalent protection margins of each assignment, taking account of the application of the procedure set out in this Article. This master copy shall contain the overall equivalent protection margins derived from that Plan as established by the 1983 Conference and those derived from all modifications to that Plan as a result of the successful completion of the modification procedure set out in this Article.

4.2.25.2 An up-to-date version of the Region 2 feeder-link Plan shall be published by the Secretary-General when justified by the circumstances.

## ARTICLE 5 (REV.WRC-19)

**Coordination, notification, examination and recording in the Master International Frequency Register of frequency assignments to feeder-link transmitting earth stations and receiving space stations in the fixed-satellite service<sup>21, 22</sup> (WRC-19)**

### 5.1 Coordination and notification

5.1.1 When an administration wishes to determine whether it is possible to use, at a given location, an amount of power control which is in excess of that contained in column 12 of the Regions 1 and 3 feeder-link Plan, it shall request the Bureau to determine the amount of permissible power control (not to exceed 10 dB) from that given location using the procedure contained in § 3.11 of Annex 3.

5.1.2 Whenever an administration<sup>23</sup> intends to bring into use a frequency assignment to a transmitting earth station or receiving space station in the fixed-satellite service in the bands between 14.5 GHz and 14.8 GHz and between 17.3 GHz and 18.1 GHz in Regions 1 and 3, and between 17.3 GHz and 17.8 GHz in Region 2, it shall notify this frequency assignment to the Bureau. For this purpose, the notifying administration shall apply the following provisions. (WRC-03)

5.1.2bis Frequency assignments relating to a number of earth stations may be notified in the form of the characteristics of a typical earth station and the intended geographical area of operation. Individual notices of frequency assignments are however necessary in the case of earth stations whose coordination area includes all or part of the territory of another administration. (WRC-03)

5.1.3 Before an administration in Region 1 or 3 notifies to the Bureau or brings into use any frequency assignment to a specific transmitting feeder-link earth station in the bands 14.5-14.8 GHz and 17.7-18.1 GHz with an e.i.r.p. greater than the sum of the values specified in columns 11 and 12 of the Regions 1 and 3 feeder-link Plan, it shall effect coordination of this assignment with each administration whose territory lies wholly or partly within the coordination area of the planned earth station using the method detailed in Appendix 7. (WRC-03)

---

<sup>21</sup> Notification of assignments to transmitting feeder-link earth stations included in the Region 2 feeder-link Plan after 2 June 2000, or included in the feeder-link List, following successful application of Article 4, shall be effected applying the provisions of Article 11 following completion of the procedure of Article 9. (WRC-03)

<sup>22</sup> If the payments are not received in accordance with the provisions of Council Decision 482, as amended, on the implementation of cost recovery for satellite network filings, the Bureau shall cancel the publication specified in § 5.1.10 and the corresponding entries in the Master Register under § 5.2.2, § 5.2.2.1, § 5.2.2.2 or § 5.2.6, as appropriate, and the corresponding entries included in the Plan on and after 3 June 2000 or in the List, as appropriate, after informing the administration concerned. The Bureau shall inform all administrations of such action. The Bureau shall send a reminder to the notifying administration not later than two months prior to the deadline for the payment in accordance with the above-mentioned Council Decision 482 unless the payment has already been received. (WRC-19)

<sup>23</sup> A frequency assignment to a space station or typical earth station in the satellite network may be notified by one administration acting on behalf of a group of named administrations. Any further notice (modification or deletion) relating to that assignment shall, in the absence of information to the contrary, be regarded as having been submitted on behalf of the entire group. (WRC-03)

5.1.4 Before an administration in Region 1 or 3 notifies to the Bureau or brings into use any frequency assignment to a specific transmitting feeder-link earth station in the bands 14.5-14.8 GHz and 17.7-18.1 GHz, it shall effect coordination of this assignment with each administration whose territory lies wholly or partly within the coordination area of the planned earth station, using the method detailed in Appendix 7, in respect of notices concerning stations of the mobile and fixed services in the bands 14.5-14.8 GHz and 17.7-18.1 GHz and of the fixed-satellite service (space-to-Earth) in the band 17.7-18.1 GHz received by the Bureau prior to 3 June 2000 for recording in the International Master Frequency Register (Master Register) and subsequently recorded with a favourable finding<sup>24</sup>. (WRC-03)

5.1.5 If an administration with which coordination is sought under § 5.1.4 does not respond within three months, the administration intending to bring into use a frequency assignment to a feeder-link earth station shall notify this frequency assignment in accordance with § 5.1.2 above.

5.1.6 For any notification under § 5.1.2, an individual notice for each frequency assignment shall be drawn up as prescribed in Appendix 4, the various sections of which specify the basic characteristics to be provided as appropriate. It is recommended that the notifying administration should also supply any other data it may consider useful.

5.1.6bis In application of § 5.1.2, an administration may identify the characteristics of assignments in the Plans or the List as notification and send to the Bureau the changes thereto. (WRC-03)

5.1.7 Each notice must reach the Bureau not earlier than three years before the date on which the frequency assignment is to be brought into use. In any case, the notice must reach the Bureau not later than three months before that date.

5.1.8 Any frequency assignment the notice of which reaches the Bureau after the applicable period specified in § 5.1.7 shall, where it is to be recorded, bear a remark in the Master Register to indicate that it is not in conformity with § 5.1.7.

5.1.9 Any notice made under § 5.1.2 which does not contain the characteristics specified in Appendix 4 shall be returned by the Bureau immediately by airmail to the notifying administration with the relevant reasons.

5.1.10 Upon receipt of a complete notice, the Bureau shall include its particulars, with the date of receipt, in its BR IFIC which shall contain the particulars of all such notices received since the publication of the previous Circular.

---

<sup>24</sup> In cases where assignments from the WRC-97 Plans without Remarks were included in the WRC-2000 Regions 1 and 3 feeder-link Plan without change, or with conversion of modulation from analogue to digital, or a change from normal roll-off to fast roll-off antenna pattern, the coordination status afforded by the WRC-97 Plans shall be preserved.

In cases where assignments from the WRC-97 Plans with Remarks were included in the WRC-2000 Regions 1 and 3 feeder-link Plan without change, or with conversion of modulation from analogue to digital, or a change from normal roll-off to fast roll-off antenna pattern, the compatibility shall be reassessed using the revised criteria and methodology in force and the Remarks of the WRC-97 Plans assignment shall either be maintained or reduced on the basis of the results of this analysis. (WRC-03)

5.1.11 The Circular shall constitute the acknowledgements to the notifying administration of the receipt of a complete notice.

5.1.12 Complete notices shall be considered by the Bureau in order of receipt. The Bureau shall not postpone its finding unless it lacks sufficient data to reach a decision; moreover, the Bureau shall not act upon any notice which has a technical bearing on an earlier notice still under consideration by the Bureau until it has reached a finding with respect to such earlier notice.

## 5.2 Examination and recording

5.2.1 The Bureau shall examine each notice:

- a) with respect to its conformity with the Convention and the relevant provisions of the Radio Regulations (with the exception of those relating to § *b*), *c*), *d*), *e*) and *f*) below); *and*
- b) with respect to its conformity with the appropriate Regional feeder-link Plan or the Regions 1 and 3 feeder-link List, as appropriate; *or* (WRC-03)
- c) with respect to the coordination requirements specified in the Remarks column of Article 9 or Article 9A; *or*
- d) with respect to its conformity with the appropriate Regional feeder-link Plan or the Regions 1 and 3 feeder-link List, however, having characteristics differing from those in this Plan or in the Regions 1 and 3 feeder-link List in one or more of the following aspects:
  - use of a reduced e.i.r.p.,
  - use of a reduced coverage area entirely situated within the coverage area appearing in the Plan or in the Regions 1 and 3 feeder-link List,
  - use of other modulating signals in accordance with the provisions of § 3.1.3 to Annex 5 of Appendix 30,
  - in the case of Region 2, use of an orbital position under the conditions specified in § B of Annex 7 to Appendix 30,
  - in the case of Regions 1 and 3, use of the assignment for transmissions in the fixed-satellite service (Earth-to-space) other than for feeder links to the broadcasting-satellite service provided that such transmissions do not cause more interference, or require more protection from interference, than the feeder-link transmissions operating in conformity with the Plan or the List, as appropriate; (WRC-03)
- e) for Region 2, with respect to its conformity with the provisions of Resolution 42 (Rev.WRC-19); (WRC-19)
- f) for Regions 1 and 3, with respect to its conformity with the provisions of § 5.1.3 and also its conformity with § 5.1.4 or 5.1.5 relating to coordination.

5.2.2 When the Bureau reaches a favourable finding with respect to § 5.2.1 *a*), 5.2.1 *b*), 5.2.1 *c*) and 5.2.1 *f*), the frequency assignment of an administration shall be recorded in the Master Register. The date of receipt of the notice by the Bureau shall be entered in the Master Register. In relations between administrations all frequency assignments brought into use in conformity with the feeder-link Plan and recorded in the Master Register shall be considered to have the same status irrespective of the dates of receipt entered in the Master Register for such frequency assignments. (WRC-07)

5.2.2.1 When the Bureau reaches a favourable finding with respect to § 5.2.1 *a*), 5.2.1 *c*), 5.2.1 *d*) and 5.2.1 *f*), the frequency assignment shall be recorded in the Master Register. The date of receipt of the notice by the Bureau shall be entered in the Master Register. In relations between administrations, all frequency assignments brought into use in conformity with the feeder-link Plan and recorded in the Master Register shall be considered to have the same status irrespective of the dates of receipt entered in the Master Register for such frequency assignments. When recording these assignments, the Bureau shall indicate by an appropriate symbol the characteristics having a value different from that appearing in that Plan. (WRC-07)

5.2.2.2 In the case of Region 2, when the Bureau reaches a favourable finding with respect to § 5.2.1 *a*) and 5.2.1 *c*) but an unfavourable finding with respect to § 5.2.1 *b*) and 5.2.1 *d*), it shall examine the notice with respect to the successful application of the provisions of Resolution 42 (Rev.WRC-19). A frequency assignment for which the provisions of Resolution 42 (Rev.WRC-19) have been successfully applied shall be recorded in the Master Register with an appropriate symbol to indicate its interim status. The date of receipt of the notice by the Bureau shall be entered in the Master Register. In relations between administrations all frequency assignments brought into use following the successful application of the provisions of Resolution 42 (Rev.WRC-19) and recorded in the Master Register shall be considered to have the same status irrespective of the dates of receipt entered in the Master Register for such frequency assignments. If the finding with respect to § 5.2.1 *e*), where applicable, is unfavourable, the notice shall be returned immediately by airmail to the notifying administration. (WRC-19)

5.2.2.3 In the case of Regions 1 and 3, when the Bureau reaches a favourable finding with respect to § 5.2.1 *a*) and 5.2.1 *c*) but an unfavourable finding with respect to § 5.2.1 *b*) and 5.2.1 *d*), the notice shall be returned immediately by airmail to the notifying administration with the Bureau's reasons for this finding and with such suggestions as the Bureau may be able to offer with a view to a satisfactory solution of the problem.

5.2.2.4 In the case of Regions 1 and 3, when the Bureau reaches a favourable finding with respect to § 5.2.1 *a*), 5.2.1 *b*), 5.2.1 *c*) and 5.2.1 *d*) but an unfavourable finding with respect to § 5.2.1 *f*), the notice shall be returned immediately by airmail to the notifying administration with the Bureau's reasons for this finding and with such suggestions as the Bureau may be able to offer with a view to a satisfactory solution of the problem. If the unfavourable finding under § 5.2.1 *f*) is due to the coordination under § 5.1.3 only not being effected, the administration shall undertake only to bring this assignment into use with an e.i.r.p. level not greater than the sum of the values specified in columns 11 and 12 of the Regions 1 and 3 feeder-link Plan.

5.2.2.5 When an assignment is recorded as a result of a favourable finding with respect to § 5.2.1 *f*), a remark shall be included indicating that coordination has been effected.

5.2.3 Whenever a frequency assignment is recorded in the Master Register, the finding reached by the Bureau shall be indicated. (WRC-07)

5.2.4 When the Bureau reaches an unfavourable finding with respect to:

- § 5.2.1 *a*), *or*
- § 5.2.1 *c*), *or*
- § 5.2.1 *b*) and 5.2.1 *d*) and, where appropriate, § 5.2.1 *e*),

the notice shall be returned immediately by airmail to the notifying administration with the Bureau's reasons for this finding and with such suggestions as the Bureau may be able to offer with a view to a satisfactory solution of the problem.

5.2.5 When the notifying administration resubmits the notice and the finding of the Bureau becomes favourable with respect to the appropriate parts of § 5.2.1, the notice shall be treated as in § 5.2.2, 5.2.2.1 or 5.2.2.2 as appropriate.

5.2.6 If the notifying administration resubmits the notice without modification and insists on its reconsideration, and if the Bureau's finding with respect to § 5.2.1 remains unfavourable, the notice is returned to the notifying administration in accordance with § 5.2.4. In this case, the notifying administration undertakes not to bring into use the frequency assignment until the condition specified in § 5.2.5 is fulfilled. For Regions 1, 2 and 3, in the event that the Bureau has been informed of agreement to new or modified frequency assignments in the Plan for a specified period of time in accordance with Article 4, the frequency assignment shall be recorded in the Master Register with a note indicating that the frequency assignment is valid only for the period specified. The notifying administration using the frequency assignment over a specified period shall not subsequently invoke this fact to justify the continued use of the frequency beyond the period specified unless it obtains the agreement of the administration(s) concerned. (WRC-19)

5.2.7 If a frequency assignment notified in advance of bringing into use in conformity with § 5.1.3 has received a favourable finding by the Bureau with respect to the provisions of § 5.2.1, it shall be entered provisionally in the Master Register with a special symbol in the Remarks Column indicating the provisional nature of that entry.

5.2.8 When the Bureau has received confirmation that the frequency assignment has been brought into use, the Bureau shall remove the symbol in the Master Register.

5.2.9 The date of bringing into use notified by the administration concerned shall be recorded in the Master Register. (WRC-07)

5.2.10 Wherever the use of a frequency assignment to a space station recorded in the Master Register and emanating from the Regions 1 and 3 List is suspended for a period exceeding six months, the notifying administration shall inform the Bureau of the date on which such use was suspended. When the recorded assignment is brought back into use, the notifying administration shall so inform the Bureau, as soon as possible. On receipt of the information sent under this provision, the Bureau shall make that information available on the ITU website as soon as possible and shall publish it in the BR IFIC. The date on which the recorded assignment is brought back into use<sup>24bis</sup> shall be no later than three years from the date on which the use of the frequency assignment was suspended, provided that the notifying administration informs the Bureau of the suspension within six months from the date on which the use was suspended. If the notifying administration informs the Bureau of the suspension more than six months after the date on which the use of the frequency assignment was suspended, this three-year time period shall be reduced. In this case, the amount by which the three-year period shall be reduced shall be equal to the amount of time that has elapsed between the end of the six-month period and the date that the Bureau is informed of the suspension. If the notifying administration informs the Bureau of the suspension more than 21 months after the date on which the use of the frequency assignment was suspended, the frequency assignment shall be cancelled. (WRC-15)

5.2.11 If a recorded frequency assignment stemming from the Regions 1 and 3 List is not brought back into use within the suspension period resulting from the application of § 5.2.10 above, the Bureau shall cancel the assignment from the Master Register and the assignment in the List, unless the assignment is one to which § 4.1.26 or § 4.1.27 is being applied. (WRC-15)

### 5.3 Cancellation of entries in the Master Register

5.3.1 Any notified frequency assignment to which the Article 4 procedures have been applied and which has been provisionally recorded under § 5.2.7 shall be brought into use no later than the end of the period provided under § 4.1.3, 4.1.3bis, 4.2.6 or 4.2.6bis of Article 4. Any other frequency assignment provisionally recorded under § 5.2.7 shall be brought into use by the date specified in the notice. Unless the Bureau has been informed by the notifying administration of the bringing into use of the assignment under § 5.2.8, it shall, no later than 15 days before the notified date of bringing into use or the end of the regulatory period established under § 4.1.3, 4.1.3bis, 4.2.6 or 4.2.6bis of Article 4, as appropriate, send a reminder requesting confirmation that the assignment has been brought into use within the regulatory period. If the Bureau does not receive that confirmation within 30 days following the notified date of bringing into use or the period provided under § 4.1.3, 4.1.3bis, 4.2.6 or 4.2.6bis of Article 4, as the case may be, it shall cancel the entry in the Master Register. (WRC-15)

5.3.2 If the use of any recorded frequency assignment is permanently discontinued, the notifying administration shall so inform the Bureau within three months, whereupon the entry shall be removed from the Master Register.

---

<sup>24bis</sup> The date of bringing back into use of a frequency assignment to a space station in the geostationary-satellite orbit shall be the commencement of the 90-day period defined below. A frequency assignment to a space station in the geostationary-satellite orbit shall be considered as having been brought back into use when a space station in the geostationary-satellite orbit with the capability of transmitting or receiving that frequency assignment has been deployed and maintained at the notified orbital position for a continuous period of 90 days. The notifying administration shall inform the Bureau within 30 days from the end of the 90-day period. Resolution 40 (Rev.WRC-19) shall apply. (WRC-19)

## ARTICLE 6 (REV.WRC-15)

**Coordination, notification and recording in the Master International Frequency Register of frequency assignments to receiving terrestrial stations in Regions 1 and 3 in the bands 14.5-14.8 GHz and 17.7-18.1 GHz, and in Region 2 in the band 17.7-17.8 GHz, when frequency assignments to feeder-link transmitting earth stations for the broadcasting-satellite service in conformity with the Regions 1 and 3 feeder-link Plan or the Region 2 feeder-link Plan<sup>25</sup> are involved<sup>26</sup>**

6.1 Administrations planning to implement assignments for terrestrial stations in Regions 1 and 3 in the bands 14.5-14.8 GHz and 17.7-18.1 GHz, and in Region 2 in the band 17.7-17.8 GHz should evaluate the level of interference assessed on the basis of coordination contours calculated in accordance with Appendix 7<sup>27</sup>, which might be caused by a feeder-link earth station located on the territory of another administration and included in the service area of an assignment to a broadcasting-satellite service feeder-link space station which is in conformity with the appropriate regional feeder-link Plan. Should the administration planning terrestrial stations find that interference may be caused by such a feeder-link earth station, it may request the administration responsible for the feeder-link earth station to indicate the geographical coordinates, the antenna characteristics and the horizon elevation angle around its existing and planned feeder-link earth stations.

6.2 In the case of Region 2, when the entry in the feeder-link Plan contains information on specific earth stations, this shall be used in the interference calculations referred to in § 6.1 above. Where such information is not contained in the Region 2 feeder-link Plan, an administration which receives a request under § 6.1 shall, within a period of four months, communicate the details of the feeder-link earth stations to the administration planning the terrestrial station, and to the Bureau in order to update this Plan.

6.3 In the case of Regions 1 and 3, an administration which receives a request under § 6.1 shall, within a period of four months, communicate the details of the feeder-link stations to the administration planning the terrestrial station, and to the Bureau for information.

6.4 If, at the end of the period of four months, the administration responsible for the terrestrial station does not receive a reply, it may request the assistance of the Bureau.

6.5 If the administration responsible for the feeder-link earth station does not communicate to the Bureau, within a period of four months, the information requested under § 6.1, this administration shall only implement its feeder-link earth station provided it does not cause harmful interference to the terrestrial station under consideration.

---

<sup>25</sup> Only assignments included in the Region 2 feeder-link Plan before 3 June 2000 shall be taken into account. (WRC-03)

<sup>26</sup> These procedures do not replace the procedures prescribed for terrestrial stations in Articles 9 and 11. (WRC-03)

<sup>27</sup> In the case of Regions 1 and 3, the feeder-link earth-station power to be taken into account is obtained by adding the values specified in Columns 11 and 12 of the feeder-link Plan.



6.6 If, as a result of the application of this Article, an agreement is reached with the administration responsible for the feeder-link earth station or no comments have been received, the administration responsible for the terrestrial station may notify this station under Article 11 for recording in the Master Register. A remark shall be included indicating either that an agreement has been reached or that no comments have been received.

## ARTICLE 7 (REV.WRC-19)

**Coordination, notification and recording in the Master International Frequency Register of frequency assignments to stations in the fixed-satellite service (space-to-Earth) in Region 1 in the frequency band 17.3-18.1 GHz and in Regions 2 and 3 in the frequency band 17.7-18.1 GHz, to stations in the fixed-satellite service (Earth-to-space) in Region 2 in the frequency bands 14.5-14.8 GHz and 17.8-18.1 GHz, to stations in the fixed-satellite service (Earth-to-space) in countries listed in Resolution 163 (WRC-15) in the frequency band 14.5-14.75 GHz and in countries listed in Resolution 164 (WRC-15) in the frequency band 14.5-14.8 GHz where those stations are not for feeder links for the broadcasting-satellite service, and to stations in the broadcasting-satellite service in Region 2 in the frequency band 17.3-17.8 GHz when frequency assignments to feeder links for broadcasting-satellite stations in the frequency bands 14.5-14.8 GHz and 17.3-18.1 GHz in Regions 1 and 3 or in the frequency band 17.3-17.8 GHz in Region 2 are involved<sup>28</sup> (Rev.WRC-19)**

### **Section I – Coordination of transmitting space or earth stations in the fixed-satellite service or transmitting space stations in the broadcasting-satellite service with assignments to broadcasting-satellite service feeder links**

7.1 The provisions of No. 9.7 and the associated provisions under Articles 9 and 11 are applicable to transmitting space stations in the fixed-satellite service in Region 1 in the frequency band 17.3-18.1 GHz, to transmitting space stations in the fixed-satellite service in Regions 2 and 3 in the frequency band 17.7-18.1 GHz, to transmitting earth stations in the fixed-satellite service in Region 2 in the frequency bands 14.5-14.8 GHz and 17.8-18.1 GHz, to transmitting earth stations in the fixed-satellite service in countries listed in Resolution 163 (WRC-15) in the frequency band 14.5-14.75 GHz and in countries listed in Resolution 164 (WRC-15) in the frequency band 14.5-14.8 GHz where those stations are not for feeder links for the broadcasting-satellite service, and to transmitting space stations in the broadcasting-satellite service in Region 2 in the frequency band 17.3-17.8 GHz. (WRC-19)

<sup>28</sup> These provisions do not replace the procedures prescribed in Articles 9 and 11 when stations other than those for feeder links in the broadcasting-satellite service subject to a Plan are involved. (WRC-03)

<sup>29</sup> (SUP – WRC-19)

7.2 In applying the procedures referred to in § 7.1, the provisions of Appendix 5 are replaced by the following:

7.2.1 The frequency assignments to be taken into account are:

- a) the assignments in conformity with the appropriate Regional feeder-link Plan in Appendix 30A;
- b) the assignments included in the Regions 1 and 3 feeder-link List;
- c) the assignments for which the procedure of Article 4 has been initiated as from the date of receipt of the complete Appendix 4 information under § 4.1.3 or 4.2.6. (WRC-03)

7.2.2 The criteria to be applied are those given in Annex 4.

7.2bis In applying the procedures referred to in § 7.1 for FSS frequency assignments in countries listed in Resolution 163 (WRC-15) in the frequency band 14.5-14.75 GHz and in countries listed in Resolution 164 (WRC-15) in the frequency band 14.5-14.8 GHz not for feeder links for the broadcasting-satellite service, the provision of No. 11.41 is replaced by the following provision. No. 11.41.2 continues to apply. (WRC-15)

7.2bis.1 If, after a notice is returned under No. 11.38, the notifying administration resubmits the notice and insists upon its reconsideration, and the assignment which was the basis of the unfavourable finding is neither an assignment in the Regions 1 and 3 Plan, nor an assignment of definitive recording in the Regions 1 and 3 feeder-link List or one for which the complete Appendix 4 information has been received under § 4.1.12 for the definitive recording by the date of submission pursuant to No. 9.30 of this notice, the Bureau shall enter the assignment in the Master Register with an indication of those administrations whose assignments were the basis of the unfavourable finding, provided that such resubmission is accompanied with a formal commitment indicating that, if unacceptable interference is caused to the Regions 1 and 3 recorded assignments which were the basis of the unfavourable finding, the notifying administration of the FSS shall immediately eliminate this unacceptable interference (see also No. 11.42). (WRC-15)

## **Section II – Coordination with assignments in conformity with the appropriate Regional feeder-link Plan in Appendix 30A**

7.3 Administrations planning to implement assignments for receiving earth stations in all Regions in the band 17.7-18.1 GHz in the fixed-satellite service (space-to-Earth) or in the band 17.3-17.8 GHz in the broadcasting-satellite service should evaluate the level of interference, assessed on the basis of coordination contours calculated in accordance with Appendix 7, which might be caused by a feeder-link earth station located on the territory of another administration and included in the service area of an assignment to a broadcasting-satellite service feeder-link space station which is in conformity with the appropriate Regional feeder-link Plan. Should the administration planning receiving earth stations find that interference may be caused by such a feeder-link earth station, it may request the administration responsible for the feeder-link earth station to indicate the geographical coordinates, the antenna characteristics and the elevation angle of the horizon around its existing and planned feeder-link earth stations.

7.4 In the case of Region 2, when the entry in the feeder-link Plan contains information on specific earth stations this shall be used in the interference calculations mentioned in § 7.3 above. Where such information is not contained in this Plan an administration which receives a request under § 7.3 shall, within a period of four months, communicate the details of the feeder-link earth stations to the administration planning the receiving earth station, and to the Bureau in order to update this Plan.

7.5 In the case of Regions 1 and 3, an administration which receives a request under § 7.3 shall, within a period of four months, communicate the details of the feeder-link earth stations to the administration planning the receiving earth station, and to the Bureau for information.

7.6 If, at the end of the period of four months, the administration responsible for the fixed-satellite or broadcasting-satellite receiving earth station(s) does not receive a reply, it may request the assistance of the Bureau.

7.7 If the administration responsible for the feeder-link earth stations does not communicate to the Bureau, within a period of four months, the information requested under § 7.3, this administration shall only implement its feeder-link earth station provided it does not cause harmful interference to the fixed-satellite or broadcasting-satellite earth station(s) under consideration.

7.8 If, as a result of the application of this Article, an agreement is reached with the administration responsible for the feeder-link earth station or no comments have been received, and where the station is recorded in the Master Register in accordance with Article 11, the Bureau shall enter a remark indicating either that an agreement has been reached or that no comments have been received.

**Section III – Coordination with assignments in the Regions 1 and 3 feeder-link List, or for which the procedure of Article 4 has been initiated**

7.9 The provisions of No. 9.17A and the associated provisions under Articles 9 and 11 and Appendix 5 are applicable to fixed-satellite service and broadcasting-satellite service receiving earth stations, in respect of frequency assignments to transmitting broadcasting-satellite service feeder-link earth stations, in the fixed-satellite service in the bands 17.3-18.1 GHz in Regions 1 and 3 and 17.3-17.8 GHz in Region 2 which correspond to assignments to receiving broadcasting-satellite service feeder-link space stations already included in the Regions 1 and 3 feeder-link List, or for which the procedure of Article 4 has been initiated, as from the date of receipt of the complete Appendix 4 information. (WRC-03)

## ARTICLE 8

**Miscellaneous provisions relating to the procedures\*****Section I – Studies and Recommendations**

8.1.1 If it is requested by any administration, the Board, using such means at its disposal as are appropriate in the circumstances, shall conduct a study of cases of alleged contravention or non-observance of these provisions, or of harmful interference.

8.1.2 The Board shall thereupon prepare and forward to the administrations concerned a report containing its findings and recommendations for the solution of the problem.

8.1.3 On receiving the Board's recommendations for the solution of the problem, an administration shall promptly acknowledge the receipt by telegram and shall subsequently indicate the action it intends to take. In cases when the Board's suggestions or recommendations are unacceptable to the administrations concerned, further efforts should be made by the Board to find an acceptable solution to the problem.

8.1.4 In a case where, as a result of a study, the Board submits to one or more administrations suggestions or recommendations for the solution of a problem, and where no answer has been received from one or more of these administrations within a period of four months, the Board shall consider that the suggestions or recommendations concerned are unacceptable to the administrations which did not answer. If it was the requesting administration which failed to answer within this period, the Board shall close the study.

**Section II – Miscellaneous provisions**

8.2.1 If it is requested by any administration, particularly by an administration of a country in need of special assistance, the Board, using such means at its disposal as are appropriate in the circumstances, shall render the following assistance:

- a) computation necessary in the application of Annexes 1, 3 and 4;
- b) any other assistance of a technical nature for completion of the procedures in this Appendix.

8.2.2 In making a request to the Board under § 8.2.1, the administration shall furnish the Board with the necessary information.

---

\* *Note by the Secretariat:* WRC-97 did not review this Article. The subject matter is also dealt with in Articles 13 and 14, which were reviewed by WRC-97.

ARTICLE 9 (REV.WRC-19)

**Plan for feeder links for the broadcasting-satellite service in the fixed-satellite service in the frequency band 17.3-17.8 GHz in Region 2**

9.1 COLUMN HEADINGS OF THE PLAN

- Col. 1 *Beam identification* (column 1 contains the symbol designating the country or the geographical area taken from Table B1 of the Preface to the International Frequency Information Circular (BR IFIC) followed by the symbol designating the service area).
- Col. 2 *Nominal orbital position*, in degrees and hundredths of a degree.
- Col. 3 *Channel number* (see Table 2 showing channel numbers and corresponding assigned frequencies).
- Col. 4 *Boresight geographical coordinates*, in degrees and hundredths of a degree.
- Col. 5 *Antenna beamwidth*. This column contains two figures corresponding to the major axis and the minor axis respectively of the elliptical cross section half-power beam, in degrees and hundredths of a degree.
- Col. 6 *Orientation of the ellipse* determined as follows: in a plane normal to the beam axis, the direction of a major axis of the ellipse is specified as the angle measured anticlockwise from a line parallel to the equatorial plane to the major axis of the ellipse to the nearest degree.
- Col. 7 *Polarization* (1 = direct, 2 = indirect)<sup>30</sup>.
- Col. 8 Earth station *e.i.r.p.* in the direction of maximum radiation, in dBW.
- Col. 9 Remarks<sup>31</sup>.

9.2 TEXT FOR NOTES IN REMARKS COLUMN OF THE PLAN

- 1 Fast roll-off space station receiving antenna as defined in Annex 3 (§ 4.6.3).
- 2 Television standard with 625 lines using greater video bandwidth and necessary bandwidth of 27 MHz.

---

<sup>30</sup> See Annex 3 (§ 4.8) to this Appendix.

<sup>31</sup> The location of earth stations, together with the antenna characteristics and elevation angle of the horizon, are given as an annex to this Plan, and will be published when the Plan is republished in accordance with § 4.2.25.2 of Article 4.

3 This assignment may cause interference to feeder-link assignments\* of Spain, Guinea-Bissau and Portugal in the Regions 1 and 3 feeder-link Plan adopted at the 1988 Conference and shall only be brought into use if:

- a) the administrations of Spain, Guinea-Bissau and Portugal agree: *or*
- b) their feeder-link equivalent protection margins, as defined in § 1.7 of Annex 3, are positive.

The affected administrations shall be informed by the notifying administration of the required changes in characteristics before this assignment is brought into use.

4 This assignment may be utilized in the geographical area of Anguilla (AIA) (which is in the beam area).

5 Feeder-link earth stations for this assignment may also be located in the territories of Puerto Rico and the United States Virgin Islands. Such operation shall not cause more interference nor require more protection than the assignment under the Plan.

6 Feeder-link earth stations for this assignment may also be located in the States of Alaska and Hawaii. Such operation shall not cause more interference nor require more protection than the assignment under the Plan.

7 The feeder-link earth station for this assignment may also be located at the point with geographical coordinates 3° 31' West, 48° 46' North. Such operation shall not cause more interference nor require more protection than the assignment under the Plan.

8 Feeder-link earth stations for this assignment may also be located at the points with the following geographical coordinates:

47° 55' West	15° 47' South	34° 53' West	08° 04' South
43° 13' West	22° 55' South	60° 02' West	03° 06' South
46° 38' West	23° 33' South	38° 31' West	12° 56' South
51° 13' West	30° 02' South	49° 15' West	16° 40' South

Such operation shall not cause more interference nor require more protection than the assignment under the Plan.

---

\* *Note by the Secretariat:* Since the orbital positions of these countries were changed by WRC-97, this paragraph might need to be revised.

9/GR . . This assignment is part of a group, the number of which follows the symbol. The group consists of the beams and has the number of channels assigned to it as indicated in Table 1.

- a) The overall equivalent protection margin to be used for the application of Article 4 and Resolution **42 (Rev.WRC-19)** shall be calculated on the following basis:
- for the calculation of interference to assignments that are part of a group, only the interference contributions from assignments that are not part of the same group are to be included; *and*
  - for the calculation of interference from assignments belonging to a group, to assignments that are not part of that same group, only the worst interference contribution from that group shall be used on a test point to test point basis. (WRC-03).
- b) If an administration notifies the same frequency in more than one beam of a group for use at the same time, the overall *C/I* produced by all emissions from that group shall not exceed the *C/I* calculated on the basis of § a) above.

TABLE 1

Group	Beams in the group	Number of channels assigned to the group
GR1	ALS00002 HWA00002 USAPSA02	32 channels
GR2	ALS00003 HWA00003 USAPSA03	32 channels
GR3	ARGINSU4 ARGSUR04	16 channels
GR4	ARGINSU5 ARGSUR05	12 channels
GR5	BOLAND01 CLMAND01 EQACAND1 EQAGAND1 PRUAND02 VENAND03	16 channels
GR6	B SU111 B SU211	32 channels
GR7	B CE311 B CE411 B CE511	32 channels
GR8	B NO611 B NO711 B NO811	32 channels
GR9	B SU112 B SU212 B CE312 B CE412	32 channels
GR10	CAN01101 CAN01201	32 channels
GR11	<i>Not used</i>	
GR12	CAN01203 CAN01303 CAN01403	32 channels
GR13	CAN01304 CAN01404 CAN01504	32 channels
GR14	CAN01405 CAN01505 CAN01605	32 channels
GR15	<i>Not used</i>	
GR16	CHLCONT4 CHLCONT6	16 channels
GR17	CHLCONT5 PAQPAC01 CHLPAC02	16 channels
GR18	CRBBER01 CRBBLZ01 CRBJMC01 CRBBAH01 CRBEC001	16 channels
GR19	EQACOO01 EQAGOO01	16 channels
GR20	PTRVIR01 USAEHO02	32 channels
GR21	PTRVIR02 USAEHO03	32 channels
GR22	VEN02VEN VEN11VEN	4 channels

*Country symbols*

1 For the explanation of symbols designating countries or geographical areas in Region 2, see the Preface to the BR IFIC.

2 One additional symbol, CRB, has been created for the purposes of the 1983 Conference only, to designate to geographical area in the Caribbean Area. The five Caribbean beams are identified as follows:

CRBBAH01, CRBBER01, CRBBLZ01, CRBEC001 and CRBJMC01

and are intended collectively to provide coverage for the following countries or geographical areas: AIA, ATG, BAH, BER, BLZ, BRB, CYM, DMA, GRD, GUY, JMC, LCA, MSR, KNA, SUR, TCA, TRD, VCT and VRG to be so used if approved by them.

TABLE 2

**Table showing correspondence between channel numbers and assigned frequencies**

<b>Channel No.</b>	<b>Assigned frequency (MHz)</b>	<b>Channel No.</b>	<b>Assigned frequency (MHz)</b>
1	17 324.00	17	17 557.28
2	17 338.58	18	17 571.86
3	17 353.16	19	17 586.44
4	17 367.74	20	17 601.02
5	17 382.32	21	17 615.60
6	17 396.90	22	17 630.18
7	17 411.48	23	17 644.76
8	17 426.06	24	17 659.34
9	17 440.64	25	17 673.92
10	17 455.22	26	17 688.50
11	17 469.80	27	17 703.08
12	17 484.38	28	17 717.66
13	17 498.96	29	17 732.24
14	17 513.54	30	17 746.82
15	17 528.12	31	17 761.40
16	17 542.70	32	17 775.98



1	2	3	4		5		6	7	8	9
ALS00002	-166.20	1	-109.94	36.86	6.04	1.11	137	1	87.4	9/GR1
ALS00003	-175.20	1	-116.23	37.50	5.60	0.75	132	1	87.4	9/GR2
ARGINSU4	-94.20	1	-52.98	-59.81	3.40	0.68	19	1	87.4	9/GR3
ARGSUR04	-94.20	1	-65.04	-43.33	3.32	1.50	40	1	87.4	9/GR3
B CE311	-64.20	1	-40.60	-6.07	3.04	2.06	174	1	87.4	8 9/GR7
B CE312	-45.20	1	-40.27	-6.06	3.44	2.09	174	1	87.4	8 9/GR9
B CE411	-64.20	1	-50.97	-15.27	3.86	1.38	49	1	87.4	8 9/GR7
B CE412	-45.20	1	-50.71	-15.30	3.57	1.56	52	1	87.4	8 9/GR9
B CE511	-64.20	1	-53.10	-2.90	2.44	2.13	104	1	87.4	8 9/GR7
B NO611	-74.20	1	-59.60	-11.62	2.85	1.69	165	2	87.4	8 9/GR8
B NO711	-74.20	1	-60.70	-1.78	3.54	1.78	126	2	87.4	8 9/GR8
B NO811	-74.20	1	-68.76	-4.71	2.37	1.65	73	2	87.4	8 9/GR8
B SU111	-81.20	1	-51.12	-25.63	2.76	1.05	50	1	87.4	8 9/GR6
B SU112	-45.20	1	-50.75	-25.62	2.47	1.48	56	1	87.4	8 9/GR9
B SU211	-81.20	1	-44.51	-16.95	3.22	1.36	60	1	87.4	8 9/GR6
B SU212	-45.20	1	-44.00	-16.87	3.20	1.96	58	1	87.4	8 9/GR9
BAHIFRB1	-87.20	1	-76.06	24.16	1.81	0.70	142	1	87.4	87.4
BERBERMU	-96.20	1	-64.77	32.32	0.60	0.60	90	2	87.4	87.4
BERBERO2	-31.00	1	-64.77	32.32	0.60	0.60	90	1	87.4	2 3
BOLAND01	-115.20	1	-71.37	-4.69	6.49	2.57	87	1	87.4	9/GR5
CAN01101	-138.20	1	-114.60	51.08	7.28	1.10	160	1	87.4	9/GR10
CAN01201	-138.20	1	-114.60	51.08	7.28	1.10	160	1	87.4	9/GR10
CAN01202	-72.70	1	-81.34	50.02	7.96	2.55	5	1	87.4	87.4
CAN01203	-129.20	1	-113.02	51.08	7.47	1.26	162	1	87.4	9/GR12
CAN01303	-129.20	1	-113.02	51.08	7.47	1.26	162	1	87.4	9/GR12
CAN01304	-91.20	1	-86.71	50.48	8.58	2.54	178	1	87.4	9/GR13
CAN01403	-129.20	1	-113.02	51.08	7.47	1.26	162	1	87.4	9/GR12
CAN01404	-91.20	1	-86.71	50.48	8.58	2.54	178	1	87.4	9/GR13
CAN01405	-82.20	1	-84.11	50.20	8.31	2.58	1	1	87.4	9/GR14
CAN01504	-91.20	1	-86.71	50.48	8.58	2.54	178	1	87.4	9/GR13
CAN01505	-82.20	1	-84.11	50.20	8.31	2.58	1	1	87.4	9/GR14
CAN01605	-82.20	1	-84.11	50.20	8.31	2.58	1	1	87.4	9/GR14
CAN01606	-70.70	1	-80.77	50.03	7.88	2.53	6	1	87.4	87.4
CHLCONT5	-106.20	1	-72.23	-35.57	2.60	0.68	55	1	87.4	9/GR17
CHLPAC02	-106.20	1	-80.06	-30.06	1.36	0.68	69	1	87.4	9/GR17
CLMAND01	-115.20	1	-71.37	-4.69	6.49	2.57	87	1	87.4	9/GR5
CLM00001	-103.20	1	-74.50	5.87	3.98	1.96	118	1	87.4	87.4
EQACAND1	-115.20	1	-71.37	-4.69	6.49	2.57	87	1	87.4	9/GR5
EQAGAND1	-115.20	1	-71.37	-4.69	6.49	2.57	87	1	87.4	9/GR5
FLKANT01	-57.20	1	-44.54	-60.13	3.54	0.68	12	1	87.4	2
FLKFALKS	-31.00	1	-59.90	-51.64	0.60	0.60	90	1	87.4	2 3
GRD00002	-42.20	1	-61.58	12.29	0.60	0.60	90	1	87.4	87.4
HWA00002	-166.20	1	-109.94	36.86	6.04	1.11	137	1	87.4	9/GR1
HWA00003	-175.20	1	-116.23	37.50	5.60	0.75	132	1	87.4	9/GR2
MEX01NTE	-78.20	1	-105.81	26.01	2.89	2.08	155	1	87.4	87.4
MEX01SUR	-69.20	1	-94.84	19.82	3.05	2.09	4	1	87.4	1
MEX02NTE	-136.20	1	-107.21	26.31	3.84	1.55	148	1	87.4	1
MEX02SUR	-127.20	1	-96.39	19.88	3.18	1.87	157	1	87.4	1
PAQPAC01	-106.20	1	-109.18	-27.53	0.60	0.60	90	1	87.4	9/GR17
PRG00002	-99.20	1	-58.66	-23.32	1.45	1.04	76	1	87.4	87.4
PRUAND02	-115.20	1	-71.37	-4.69	6.49	2.57	87	1	87.4	9/GR5
PTRVIR01	-101.20	1	-93.94	36.32	8.24	3.56	171	1	87.4	1 6 9/GR20
PTRVIR02	-110.20	1	-95.23	36.29	8.27	3.37	168	1	87.4	1 6 9/GR21
SPMFRAN3	-53.20	1	-67.24	47.51	3.16	0.79	7	1	87.4	2 7
TRD00001	-84.70	1	-61.23	10.70	0.60	0.60	90	1	87.4	87.4
URG00001	-71.70	1	-56.22	-32.52	1.02	0.89	11	1	87.4	87.4
USAEH001	-61.70	1	-87.57	36.17	6.42	3.49	12	1	87.4	1 5 6
USAEH002	-101.20	1	-93.94	36.32	8.24	3.56	171	1	87.4	1 6 9/GR20
USAEH003	-110.20	1	-95.23	36.29	8.27	3.37	168	1	87.4	1 6 9/GR21
USAEH004	-119.20	1	-96.45	36.21	8.20	3.12	165	1	87.4	1 5 6
USAPSA02	-166.20	1	-109.94	36.86	6.04	1.11	137	1	87.4	9/GR1
USAPSA03	-175.20	1	-116.23	37.50	5.60	0.75	132	1	87.4	9/GR2
USAWH101	-148.20	1	-111.02	40.68	4.36	2.15	162	1	87.4	87.4
USAWH102	-157.20	1	-113.07	40.74	3.72	1.78	149	1	87.4	87.4
VENAND03	-115.20	1	-71.37	-4.69	6.49	2.57	87	1	87.4	9/GR5
VRG00001	-79.70	1	-64.37	18.48	0.60	0.60	90	1	87.4	4

17 338.58 MHz (2)

1	2	3	4	5	6	7	8	9		
ALS00002	-165.80	2	-109.83	36.82	6.03	1.12	137	2	87.4	9/GR1
ALS00003	-174.80	2	-116.10	37.47	5.60	0.76	132	2	87.4	9/GR2
ARGNORT4	-93.80	2	-63.96	-30.01	3.86	1.99	48	2	87.4	
ARGNORT5	-54.80	2	-62.85	-29.80	3.24	2.89	47	2	87.4	
ATNBEM1	-52.80	2	-66.44	14.87	1.83	0.68	39	2	87.4	
B CE311	-63.80	2	-40.60	-6.07	3.04	2.06	174	2	87.4	8 9/GR7
B CE312	-44.80	2	-40.26	-6.06	3.44	2.09	174	2	87.4	8 9/GR9
B CE411	-63.80	2	-50.97	-15.26	3.86	1.38	49	2	87.4	8 9/GR7
B CE412	-44.80	2	-50.71	-15.30	3.57	1.56	52	2	87.4	8 9/GR9
B CE511	-63.80	2	-53.11	-2.98	2.42	2.15	107	2	87.4	8 9/GR7
B NO611	-73.80	2	-59.60	-11.62	2.86	1.69	165	1	87.4	8 9/GR8
B NO711	-73.80	2	-60.70	-1.78	3.54	1.78	126	1	87.4	8 9/GR8
B NO811	-73.80	2	-68.75	-4.71	2.37	1.65	73	1	87.4	8 9/GR8
B SE911	-101.80	2	-45.99	-19.09	2.22	0.79	62	2	87.4	8
B SU111	-80.80	2	-51.10	-25.64	2.76	1.06	50	2	87.4	8 9/GR6
B SU112	-44.80	2	-50.76	-25.62	2.47	1.48	56	2	87.4	8 9/GR9
B SU211	-80.80	2	-44.51	-16.94	3.22	1.37	60	2	87.4	8 9/GR6
B SU212	-44.80	2	-43.99	-16.97	3.27	1.92	59	2	87.4	8 9/GR9
CAN01101	-137.80	2	-114.10	50.92	7.22	1.11	160	2	87.4	9/GR10
CAN01201	-137.80	2	-114.10	50.92	7.22	1.11	160	2	87.4	9/GR10
CAN01202	-72.30	2	-81.23	50.12	7.99	2.53	5	2	87.4	
CAN01203	-128.80	2	-113.04	51.04	7.53	1.26	162	2	87.4	9/GR12
CAN01303	-128.80	2	-113.04	51.04	7.53	1.26	162	2	87.4	9/GR12
CAN01304	-90.80	2	-86.57	50.48	8.59	2.54	178	2	87.4	9/GR13
CAN01403	-128.80	2	-113.04	51.04	7.53	1.26	162	2	87.4	9/GR12
CAN01404	-90.80	2	-86.57	50.48	8.59	2.54	178	2	87.4	9/GR13
CAN01405	-81.80	2	-83.80	50.22	8.35	2.57	2	2	87.4	9/GR14
CAN01504	-90.80	2	-86.57	50.48	8.59	2.54	178	2	87.4	9/GR13
CAN01505	-81.80	2	-83.80	50.22	8.35	2.57	2	2	87.4	9/GR14
CAN01605	-81.80	2	-83.80	50.22	8.35	2.57	2	2	87.4	9/GR14
CAN01606	-70.30	2	-80.64	50.02	7.88	2.52	6	2	87.4	
CHLCONT4	-105.80	2	-69.59	-23.20	2.21	0.69	68	2	87.4	9/GR16
CHLCONH6	-105.80	2	-73.52	-55.52	3.65	1.31	39	2	87.4	9/GR16
CRBBA01	-92.30	2	-76.09	24.13	1.83	0.68	141	1	87.4	9/GR18
CRBBER01	-92.30	2	-64.76	32.13	0.60	0.60	90	1	87.4	9/GR18
CRBBLZ01	-92.30	2	-88.61	17.26	0.64	0.64	90	1	87.4	9/GR18
CRBEC001	-92.30	2	-60.07	8.26	4.20	0.86	115	1	87.4	9/GR18
CRBJMCO1	-92.30	2	-79.45	17.97	0.99	0.68	151	1	87.4	9/GR18
CTRO0201	-130.80	2	-84.33	9.67	0.82	0.68	119	2	87.4	
EQAC0001	-94.80	2	-78.31	-1.52	1.48	1.15	65	1	87.4	9/GR19
EQAG0001	-94.80	2	-90.36	-0.57	0.94	0.89	99	1	87.4	9/GR19
GUY00302	-33.80	2	-59.07	4.77	1.43	0.85	91	2	87.4	
HNDIFRB2	-107.30	2	-86.23	15.16	1.14	0.85	8	1	87.4	
HTI00002	-83.30	2	-73.28	18.96	0.82	0.68	11	2	87.4	
HWA00002	-165.80	2	-109.83	36.82	6.03	1.12	137	2	87.4	9/GR1
HWA00003	-174.80	2	-116.10	37.47	5.60	0.76	132	2	87.4	9/GR2
MEX01NTE	-77.80	2	-105.80	25.99	2.88	2.07	155	2	87.4	1
MEX02NTE	-135.80	2	-107.36	26.32	3.80	1.57	149	2	87.4	1
MEX02SUR	-126.80	2	-96.39	19.88	3.19	1.87	158	2	87.4	1
PRU00004	-85.80	2	-74.19	-8.39	3.74	2.45	112	2	87.4	
PTRVIR01	-100.80	2	-93.85	36.31	8.26	3.55	171	2	87.4	1 6 9/GR20
PTRVIR02	-109.80	2	-95.47	36.38	8.10	3.45	168	2	87.4	1 6 9/GR21
TCA00001	-115.80	2	-71.79	21.53	0.60	0.60	90	2	87.4	
USAEH001	-61.30	2	-87.53	36.18	6.41	3.49	12	2	87.4	1 5 6
USAEH002	-100.80	2	-93.85	36.31	8.26	3.55	171	2	87.4	1 6 9/GR20
USAEH003	-109.80	2	-95.47	36.38	8.10	3.45	168	2	87.4	1 6 9/GR21
USAEH004	-118.80	2	-96.42	36.21	8.20	3.12	165	2	87.4	1 5 6
USAPSA02	-165.80	2	-109.83	36.82	6.03	1.12	137	2	87.4	9/GR1
USAPSA03	-174.80	2	-116.10	37.47	5.60	0.76	132	2	87.4	9/GR2
USAWH101	-147.80	2	-111.01	40.67	4.38	2.15	162	2	87.4	
USAWH102	-156.80	2	-113.01	40.71	3.74	1.79	149	2	87.4	
VCT00001	-79.30	2	-61.18	13.23	0.60	0.60	90	2	87.4	
VEN11VEN	-103.80	2	-66.79	6.90	2.50	1.77	122	2	87.4	

1	2	3	4		5		6	7	8	9
ALS00002	-166.20	3	-109.94	36.86	6.04	1.11	137	1	87.4	9/GR1
ALS00003	-175.20	3	-116.23	37.50	5.60	0.75	132	1	87.4	9/GR2
ARGINSU4	-94.20	3	-52.98	-59.81	3.40	0.68	19	1	87.4	9/GR3
ARGINSU5	-55.20	3	-44.17	-59.91	3.77	0.70	13	1	87.4	9/GR4
ARGSUR04	-94.20	3	-65.04	-43.33	3.32	1.50	40	1	87.4	9/GR3
ARGSUR05	-55.20	3	-63.68	-43.01	2.54	2.38	152	1	87.4	9/GR4
ATGSJN01	-79.70	3	-61.79	17.07	0.60	0.60	90	1	87.4	
B CE311	-64.20	3	-40.60	-6.07	3.04	2.06	174	1	87.4	8 9/GR7
B CE312	-45.20	3	-40.27	-6.06	3.44	2.09	174	1	87.4	8 9/GR9
B CE411	-64.20	3	-50.97	-15.27	3.86	1.38	49	1	87.4	8 9/GR7
B CE412	-45.20	3	-50.71	-15.30	3.57	1.56	52	1	87.4	8 9/GR9
B CE511	-64.20	3	-53.10	-2.90	2.44	2.13	104	1	87.4	8 9/GR7
B NO611	-74.20	3	-59.60	-11.62	2.85	1.69	165	2	87.4	8 9/GR8
B NO711	-74.20	3	-60.70	-1.78	3.54	1.78	126	2	87.4	8 9/GR8
B NO811	-74.20	3	-68.76	-4.71	2.37	1.65	73	2	87.4	8 9/GR8
B SU111	-81.20	3	-51.12	-25.63	2.76	1.05	50	1	87.4	8 9/GR6
B SU112	-45.20	3	-50.75	-25.62	2.47	1.48	56	1	87.4	8 9/GR9
B SU211	-81.20	3	-44.51	-16.95	3.22	1.36	60	1	87.4	8 9/GR6
B SU212	-45.20	3	-44.00	-16.87	3.20	1.96	58	1	87.4	8 9/GR9
BERBERMU	-96.20	3	-64.77	32.32	0.60	0.60	90	2	87.4	
BOLAND01	-115.20	3	-71.37	-4.69	6.49	2.57	87	1	87.4	9/GR5
BOL00001	-87.20	3	-64.61	-16.71	2.52	2.19	85	1	87.4	
BRB00001	-92.70	3	-59.85	12.93	0.60	0.60	90	2	87.4	
CAN01101	-138.20	3	-114.60	51.08	7.28	1.10	160	1	87.4	9/GR10
CAN01201	-138.20	3	-114.60	51.08	7.28	1.10	160	1	87.4	9/GR10
CAN01202	-72.70	3	-81.34	50.02	7.96	2.55	5	1	87.4	
CAN01203	-129.20	3	-113.02	51.08	7.47	1.26	162	1	87.4	9/GR12
CAN01303	-129.20	3	-113.02	51.08	7.47	1.26	162	1	87.4	9/GR12
CAN01304	-91.20	3	-86.71	50.48	8.58	2.54	178	1	87.4	9/GR13
CAN01403	-129.20	3	-113.02	51.08	7.47	1.26	162	1	87.4	9/GR12
CAN01404	-91.20	3	-86.71	50.48	8.58	2.54	178	1	87.4	9/GR13
CAN01405	-82.20	3	-84.11	50.20	8.31	2.58	1	1	87.4	9/GR14
CAN01504	-91.20	3	-86.71	50.48	8.58	2.54	178	1	87.4	9/GR13
CAN01505	-82.20	3	-84.11	50.20	8.31	2.58	1	1	87.4	9/GR14
CAN01605	-82.20	3	-84.11	50.20	8.31	2.58	1	1	87.4	9/GR14
CAN01606	-70.70	3	-80.77	50.03	7.88	2.53	6	1	87.4	
CHLCONT5	-106.20	3	-72.23	-35.57	2.60	0.68	55	1	87.4	9/GR17
CHLPAC02	-106.20	3	-80.06	-30.06	1.36	0.68	69	1	87.4	9/GR17
CLMAND01	-115.20	3	-71.37	-4.69	6.49	2.57	87	1	87.4	9/GR5
CLM00001	-103.20	3	-74.50	5.87	3.98	1.96	118	1	87.4	
CUB00001	-89.20	3	-79.81	21.62	2.24	0.68	168	1	87.4	
EQACAND1	-115.20	3	-71.37	-4.69	6.49	2.57	87	1	87.4	9/GR5
EQAGAND1	-115.20	3	-71.37	-4.69	6.49	2.57	87	1	87.4	9/GR5
GRD00002	-42.20	3	-61.58	12.29	0.60	0.60	90	1	87.4	
GRD00059	-57.20	3	-61.58	12.29	0.60	0.60	90	1	87.4	
GRLDNK01	-53.20	3	-44.89	66.56	2.70	0.82	173	1	87.4	2
HWA00002	-166.20	3	-109.94	36.86	6.04	1.11	137	1	87.4	9/GR1
HWA00003	-175.20	3	-116.23	37.50	5.60	0.75	132	1	87.4	9/GR2
MEX01NTE	-78.20	3	-105.81	26.01	2.89	2.08	155	1	87.4	1
MEX01SUR	-69.20	3	-94.84	19.82	3.05	2.09	4	1	87.4	1
MEX02NTE	-136.20	3	-107.21	26.31	3.84	1.55	148	1	87.4	1
MEX02SUR	-127.20	3	-96.39	19.88	3.18	1.87	157	1	87.4	1
PAQPAC01	-106.20	3	-109.18	-27.53	0.60	0.60	90	1	87.4	9/GR17
PRG00002	-99.20	3	-58.66	-23.32	1.45	1.04	76	1	87.4	
PRUAND02	-115.20	3	-71.37	-4.69	6.49	2.57	87	1	87.4	9/GR5
PTRVIR01	-101.20	3	-93.94	36.32	8.24	3.56	171	1	87.4	1 6 9/GR20
PTRVIR02	-110.20	3	-95.23	36.29	8.27	3.37	168	1	87.4	1 6 9/GR21
SURINAM2	-84.70	3	-55.69	4.35	1.00	0.69	86	1	87.4	
URG00001	-71.70	3	-56.22	-32.52	1.02	0.89	11	1	87.4	
USAEH001	-61.70	3	-87.57	36.17	6.42	3.49	12	1	87.4	1 5 6
USAEH002	-101.20	3	-93.94	36.32	8.24	3.56	171	1	87.4	1 6 9/GR20
USAEH003	-110.20	3	-95.23	36.29	8.27	3.37	168	1	87.4	1 6 9/GR21
USAEH004	-119.20	3	-96.45	36.21	8.20	3.12	165	1	87.4	1 5 6
USAPSA02	-166.20	3	-109.94	36.86	6.04	1.11	137	1	87.4	9/GR1
USAPSA03	-175.20	3	-116.23	37.50	5.60	0.75	132	1	87.4	9/GR2
USAWH101	-148.20	3	-111.02	40.68	4.36	2.15	162	1	87.4	
USAWH102	-157.20	3	-113.07	40.74	3.72	1.78	149	1	87.4	
VENAND03	-115.20	3	-71.37	-4.69	6.49	2.57	87	1	87.4	9/GR5

17 367.74 MHz (4)

1	2	3	4		5		6	7	8	9
ALS00002	-165.80	4	-109.83	36.82	6.03	1.12	137	2	87.4	9/GR1
ALS00003	-174.80	4	-116.10	37.47	5.60	0.76	132	2	87.4	9/GR2
ARGNORT4	-93.80	4	-63.96	-30.01	3.86	1.99	48	2	87.4	
ARGNORT5	-54.80	4	-62.85	-29.80	3.24	2.89	47	2	87.4	
B CE311	-63.80	4	-40.60	-6.07	3.04	2.06	174	2	87.4	8 9/GR7
B CE312	-44.80	4	-40.26	-6.06	3.44	2.09	174	2	87.4	8 9/GR9
B CE411	-63.80	4	-50.97	-15.26	3.86	1.38	49	2	87.4	8 9/GR7
B CE412	-44.80	4	-50.71	-15.30	3.57	1.56	52	2	87.4	8 9/GR9
B CE511	-63.80	4	-53.11	-2.98	2.42	2.15	107	2	87.4	8 9/GR7
B NO611	-73.80	4	-59.60	-11.62	2.86	1.69	165	1	87.4	8 9/GR8
B NO711	-73.80	4	-60.70	-1.78	3.54	1.78	126	1	87.4	8 9/GR8
B NOR11	-73.80	4	-68.75	-4.71	2.37	1.65	73	1	87.4	8 9/GR8
B SE911	-101.80	4	-45.99	-19.09	2.22	0.79	62	2	87.4	8
B SU111	-80.80	4	-51.10	-25.64	2.76	1.06	50	2	87.4	8 9/GR6
B SU112	-44.80	4	-50.76	-25.62	2.47	1.48	56	2	87.4	8 9/GR9
B SU211	-80.80	4	-44.51	-16.94	3.22	1.37	60	2	87.4	8 9/GR6
B SU212	-44.80	4	-43.99	-16.97	3.27	1.92	59	2	87.4	8 9/GR9
CAN01101	-137.80	4	-114.10	50.92	7.22	1.11	160	2	87.4	9/GR10
CAN01201	-137.80	4	-114.10	50.92	7.22	1.11	160	2	87.4	9/GR10
CAN01202	-72.30	4	-81.23	50.12	7.99	2.53	5	2	87.4	
CAN01203	-128.80	4	-113.04	51.04	7.53	1.26	162	2	87.4	9/GR12
CAN01303	-128.80	4	-113.04	51.04	7.53	1.26	162	2	87.4	9/GR12
CAN01304	-90.80	4	-86.57	50.48	8.59	2.54	178	2	87.4	9/GR13
CAN01403	-128.80	4	-113.04	51.04	7.53	1.26	162	2	87.4	9/GR12
CAN01404	-90.80	4	-86.57	50.48	8.59	2.54	178	2	87.4	9/GR13
CAN01405	-81.80	4	-83.80	50.22	8.35	2.57	2	2	87.4	9/GR14
CAN01504	-90.80	4	-86.57	50.48	8.59	2.54	178	2	87.4	9/GR13
CAN01505	-81.80	4	-83.80	50.22	8.35	2.57	2	2	87.4	9/GR14
CAN01605	-81.80	4	-83.80	50.22	8.35	2.57	2	2	87.4	9/GR14
CAN01606	-70.30	4	-80.64	50.02	7.88	2.52	6	2	87.4	
CHLCONT4	-105.80	4	-69.59	-23.20	2.21	0.69	68	2	87.4	9/GR16
CHLCONT6	-105.80	4	-73.52	-55.52	3.65	1.31	39	2	87.4	9/GR16
CRBBAH01	-92.30	4	-76.09	24.13	1.83	0.68	141	1	87.4	9/GR18
CRBBER01	-92.30	4	-64.76	32.13	0.60	0.60	90	1	87.4	9/GR18
CRBBLZ01	-92.30	4	-88.61	17.26	0.64	0.64	90	1	87.4	9/GR18
CRBEC001	-92.30	4	-60.07	8.26	4.20	0.86	115	1	87.4	9/GR18
CRBJMC01	-92.30	4	-79.45	17.97	0.99	0.68	151	1	87.4	9/GR18
CYM00001	-115.80	4	-80.58	19.57	0.60	0.60	90	2	87.4	
DOMIFRB2	-83.30	4	-70.51	18.79	0.98	0.69	167	2	87.4	
EQAC0001	-94.80	4	-78.31	-1.52	1.48	1.15	65	1	87.4	9/GR19
EQAG0001	-94.80	4	-90.36	-0.57	0.94	0.89	99	1	87.4	9/GR19
GUFMGG02	-52.80	4	-56.42	8.47	4.16	0.81	123	2	87.4	2 7
HWA00002	-165.80	4	-109.83	36.82	6.03	1.12	137	2	87.4	9/GR1
HWA00003	-174.80	4	-116.10	37.47	5.60	0.76	132	2	87.4	9/GR2
JMC00005	-33.80	4	-77.27	18.12	0.60	0.60	90	2	87.4	
LCAIFRB1	-79.30	4	-61.15	13.90	0.60	0.60	90	2	87.4	
MEX01NTE	-77.80	4	-105.80	25.99	2.88	2.07	155	2	87.4	1
MEX02NTE	-135.80	4	-107.36	26.32	3.80	1.57	149	2	87.4	1
MEX02SUR	-126.80	4	-96.39	19.88	3.19	1.87	158	2	87.4	1
PRU00004	-85.80	4	-74.19	-8.39	3.74	2.45	112	2	87.4	
PTRVIR01	-100.80	4	-93.85	36.31	8.26	3.55	171	2	87.4	1 6 9/GR20
PTRVIR02	-109.80	4	-95.47	36.38	8.10	3.45	168	2	87.4	1 6 9/GR21
SLVIFRB2	-107.30	4	-88.91	13.59	0.60	0.60	90	1	87.4	
USAEH001	-61.30	4	-87.53	36.18	6.41	3.49	12	2	87.4	1 5 6
USAEH002	-100.80	4	-93.85	36.31	8.26	3.55	171	2	87.4	1 6 9/GR20
USAEH003	-109.80	4	-95.47	36.38	8.10	3.45	168	2	87.4	1 6 9/GR21
USAEH004	-118.80	4	-96.42	36.21	8.20	3.12	165	2	87.4	1 5 6
USAPSA02	-165.80	4	-109.83	36.82	6.03	1.12	137	2	87.4	9/GR1
USAPSA03	-174.80	4	-116.10	37.47	5.60	0.76	132	2	87.4	9/GR2
USAWH101	-147.80	4	-111.01	40.67	4.38	2.15	162	2	87.4	
USAWH102	-156.80	4	-113.01	40.71	3.74	1.79	149	2	87.4	
VEN11VEN	-103.80	4	-66.79	6.90	2.50	1.77	122	2	87.4	

1	2	3	4		5		6	7	8	9
ALS00002	-166.20	5	-109.94	36.86	6.04	1.11	137	1	87.4	9/GR1
ALS00003	-175.20	5	-116.23	37.50	5.60	0.75	132	1	87.4	9/GR2
ARGINSU4	-94.20	5	-52.98	-59.81	3.40	0.68	19	1	87.4	9/GR3
ARGSUR04	-94.20	5	-65.04	-43.33	3.32	1.50	40	1	87.4	9/GR3
B CE311	-64.20	5	-40.60	-6.07	3.04	2.06	174	1	87.4	89/GR7
B CE312	-45.20	5	-40.27	-6.06	3.44	2.09	174	1	87.4	89/GR9
B CE411	-64.20	5	-50.97	-15.27	3.86	1.38	49	1	87.4	89/GR7
B CE412	-45.20	5	-50.71	-15.30	3.57	1.56	52	1	87.4	89/GR9
B CE511	-64.20	5	-53.10	-2.90	2.44	2.13	104	1	87.4	89/GR7
B NO611	-74.20	5	-59.60	-11.62	2.85	1.69	165	2	87.4	89/GR8
B NO711	-74.20	5	-60.70	-1.78	3.54	1.78	126	2	87.4	89/GR8
B NO811	-74.20	5	-68.76	-4.71	2.37	1.65	73	2	87.4	89/GR8
B SU111	-81.20	5	-51.12	-25.63	2.76	1.05	50	1	87.4	89/GR6
B SU112	-45.20	5	-50.75	-25.62	2.47	1.48	56	1	87.4	89/GR9
B SU211	-81.20	5	-44.51	-16.95	3.22	1.36	60	1	87.4	89/GR6
B SU212	-45.20	5	-44.00	-16.87	3.20	1.96	58	1	87.4	89/GR9
BAHIFRB1	-87.20	5	-76.06	24.16	1.81	0.70	142	1	87.4	
BERBERMU	-96.20	5	-64.77	32.32	0.60	0.60	90	2	87.4	
BERBERO2	-31.00	5	-64.77	32.32	0.60	0.60	90	1	87.4	2 3
BOLAND01	-115.20	5	-71.37	-4.69	6.49	2.57	87	1	87.4	9/GR5
CAN01101	-138.20	5	-114.60	51.08	7.28	1.10	160	1	87.4	9/GR10
CAN01201	-138.20	5	-114.60	51.08	7.28	1.10	160	1	87.4	9/GR10
CAN01202	-72.70	5	-81.34	50.02	7.96	2.55	5	1	87.4	
CAN01203	-129.20	5	-113.02	51.08	7.47	1.26	162	1	87.4	9/GR12
CAN01303	-129.20	5	-113.02	51.08	7.47	1.26	162	1	87.4	9/GR12
CAN01304	-91.20	5	-86.71	50.48	8.58	2.54	178	1	87.4	9/GR13
CAN01403	-129.20	5	-113.02	51.08	7.47	1.26	162	1	87.4	9/GR12
CAN01404	-91.20	5	-86.71	50.48	8.58	2.54	178	1	87.4	9/GR13
CAN01405	-82.20	5	-84.11	50.20	8.31	2.58	1	1	87.4	9/GR14
CAN01504	-91.20	5	-86.71	50.48	8.58	2.54	178	1	87.4	9/GR13
CAN01505	-82.20	5	-84.11	50.20	8.31	2.58	1	1	87.4	9/GR14
CAN01605	-82.20	5	-84.11	50.20	8.31	2.58	1	1	87.4	9/GR14
CAN01606	-70.70	5	-80.77	50.03	7.88	2.53	6	1	87.4	
CHLCONT5	-106.20	5	-72.23	-35.57	2.60	0.68	55	1	87.4	9/GR17
CHLPAC02	-106.20	5	-80.06	-30.06	1.36	0.68	69	1	87.4	9/GR17
CLMAND01	-115.20	5	-71.37	-4.69	6.49	2.57	87	1	87.4	9/GR5
CLM00001	-103.20	5	-74.50	5.87	3.98	1.96	118	1	87.4	
EQACAND1	-115.20	5	-71.37	-4.69	6.49	2.57	87	1	87.4	9/GR5
EQAGAND1	-115.20	5	-71.37	-4.69	6.49	2.57	87	1	87.4	9/GR5
FLKANT01	-57.20	5	-44.54	-60.13	3.54	0.68	12	1	87.4	2
FLKFALKS	-31.00	5	-59.90	-51.64	0.60	0.60	90	1	87.4	2 3
GRD00002	-42.20	5	-61.58	12.29	0.60	0.60	90	1	87.4	
HWA00002	-166.20	5	-109.94	36.86	6.04	1.11	137	1	87.4	9/GR1
HWA00003	-175.20	5	-116.23	37.50	5.60	0.75	132	1	87.4	9/GR2
MEX01NTE	-78.20	5	-105.81	26.01	2.89	2.08	155	1	87.4	1
MEX01SUR	-69.20	5	-94.84	19.82	3.05	2.09	4	1	87.4	1
MEX02NTE	-136.20	5	-107.21	26.31	3.84	1.55	148	1	87.4	1
MEX02SUR	-127.20	5	-96.39	19.88	3.18	1.87	157	1	87.4	1
PAQPAC01	-106.20	5	-109.18	-27.53	0.60	0.60	90	1	87.4	9/GR17
PRG00002	-99.20	5	-58.66	-23.32	1.45	1.04	76	1	87.4	
PRUAND02	-115.20	5	-71.37	-4.69	6.49	2.57	87	1	87.4	9/GR5
PTRVIR01	-101.20	5	-93.94	36.32	8.24	3.56	171	1	87.4	169/GR20
PTRVIR02	-110.20	5	-95.23	36.29	8.27	3.37	168	1	87.4	169/GR21
SPMFRAN3	-53.20	5	-67.24	47.51	3.16	0.79	7	1	87.4	2 7
TRD00001	-84.70	5	-61.23	10.70	0.60	0.60	90	1	87.4	
URG00001	-71.70	5	-56.22	-32.52	1.02	0.89	11	1	87.4	
USAEH001	-61.70	5	-87.57	36.17	6.42	3.49	12	1	87.4	156
USAEH002	-101.20	5	-93.94	36.32	8.24	3.56	171	1	87.4	169/GR20
USAEH003	-110.20	5	-95.23	36.29	8.27	3.37	168	1	87.4	169/GR21
USAEH004	-119.20	5	-96.45	36.21	8.20	3.12	165	1	87.4	156
USAPSA02	-166.20	5	-109.94	36.86	6.04	1.11	137	1	87.4	9/GR1
USAPSA03	-175.20	5	-116.23	37.50	5.60	0.75	132	1	87.4	9/GR2
USAWH101	-148.20	5	-111.02	40.68	4.36	2.15	162	1	87.4	
USAWH102	-157.20	5	-113.07	40.74	3.72	1.78	149	1	87.4	
VENAND03	-115.20	5	-71.37	-4.69	6.49	2.57	87	1	87.4	9/GR5
VRG00001	-79.70	5	-64.37	18.48	0.60	0.60	90	1	87.4	4

17 396.90 MHz (6)

1	2	3	4		5		6	7	8	9
ALS00002	-165.80	6	-109.83	36.82	6.03	1.12	137	2	87.4	9/GR1
ALS00003	-174.80	6	-116.10	37.47	5.60	0.76	132	2	87.4	9/GR2
ARGNORT4	-93.80	6	-63.96	-30.01	3.86	1.99	48	2	87.4	
ARGNORT5	-54.80	6	-62.85	-29.80	3.24	2.89	47	2	87.4	
ATNBEAM1	-52.80	6	-66.44	14.87	1.83	0.68	39	2	87.4	
B CE311	-63.80	6	-40.60	-6.07	3.04	2.06	174	2	87.4	8 9/GR7
B CE312	-44.80	6	-40.26	-6.06	3.44	2.09	174	2	87.4	8 9/GR9
B CE411	-63.80	6	-50.97	-15.26	3.86	1.38	49	2	87.4	8 9/GR7
B CE412	-44.80	6	-50.71	-15.30	3.57	1.56	52	2	87.4	8 9/GR9
B CE511	-63.80	6	-53.11	-2.98	2.42	2.15	107	2	87.4	8 9/GR7
B NO611	-73.80	6	-59.60	-11.62	2.86	1.69	165	1	87.4	8 9/GR8
B NO711	-73.80	6	-60.70	-1.78	3.54	1.78	126	1	87.4	8 9/GR8
B NO811	-73.80	6	-68.75	-4.71	2.37	1.65	73	1	87.4	8 9/GR8
B SE911	-101.80	6	-45.99	-19.09	2.22	0.79	62	2	87.4	8
B SU111	-80.80	6	-51.10	-25.64	2.76	1.06	50	2	87.4	8 9/GR6
B SU112	-44.80	6	-50.76	-25.62	2.47	1.48	56	2	87.4	8 9/GR9
B SU211	-80.80	6	-44.51	-16.94	3.22	1.37	60	2	87.4	8 9/GR6
B SU212	-44.80	6	-43.99	-16.97	3.27	1.92	59	2	87.4	8 9/GR9
CAN01101	-137.80	6	-114.10	50.92	7.22	1.11	160	2	87.4	9/GR10
CAN01201	-137.80	6	-114.10	50.92	7.22	1.11	160	2	87.4	9/GR10
CAN01202	-72.30	6	-81.23	50.12	7.99	2.53	5	2	87.4	
CAN01203	-128.80	6	-113.04	51.04	7.53	1.26	162	2	87.4	9/GR12
CAN01303	-128.80	6	-113.04	51.04	7.53	1.26	162	2	87.4	9/GR12
CAN01304	-90.80	6	-86.57	50.48	8.59	2.54	178	2	87.4	9/GR13
CAN01403	-128.80	6	-113.04	51.04	7.53	1.26	162	2	87.4	9/GR12
CAN01404	-90.80	6	-86.57	50.48	8.59	2.54	178	2	87.4	9/GR13
CAN01405	-81.80	6	-83.80	50.22	8.35	2.57	2	2	87.4	9/GR14
CAN01504	-90.80	6	-86.57	50.48	8.59	2.54	178	2	87.4	9/GR13
CAN01505	-81.80	6	-83.80	50.22	8.35	2.57	2	2	87.4	9/GR14
CAN01605	-81.80	6	-83.80	50.22	8.35	2.57	2	2	87.4	9/GR14
CAN01606	-70.30	6	-80.64	50.02	7.88	2.52	6	2	87.4	
CHLCONT4	-105.80	6	-69.59	-23.20	2.21	0.69	68	2	87.4	9/GR16
CHLCONT6	-105.80	6	-73.52	-55.52	3.65	1.31	39	2	87.4	9/GR16
CRBBAH01	-92.30	6	-76.09	24.13	1.83	0.68	141	1	87.4	9/GR18
CRBBER01	-92.30	6	-64.76	32.13	0.60	0.60	90	1	87.4	9/GR18
CRBBLZ01	-92.30	6	-88.61	17.26	0.64	0.64	90	1	87.4	9/GR18
CRBEC001	-92.30	6	-60.07	8.26	4.20	0.86	115	1	87.4	9/GR18
CRBJMC01	-92.30	6	-79.45	17.97	0.99	0.68	151	1	87.4	9/GR18
CTR00201	-130.80	6	-84.33	9.67	0.82	0.68	119	2	87.4	
EQAC0001	-94.80	6	-78.31	-1.52	1.48	1.15	65	1	87.4	9/GR19
EQAG0001	-94.80	6	-90.36	-0.57	0.94	0.89	99	1	87.4	9/GR19
GUY00302	-33.80	6	-59.07	4.77	1.43	0.85	91	2	87.4	
HNDIFRB2	-107.30	6	-86.23	15.16	1.14	0.85	8	1	87.4	
HTI00002	-83.30	6	-73.28	18.96	0.82	0.68	11	2	87.4	
HWA00002	-165.80	6	-109.83	36.82	6.03	1.12	137	2	87.4	9/GR1
HWA00003	-174.80	6	-116.10	37.47	5.60	0.76	132	2	87.4	9/GR2
MEX01NTE	-77.80	6	-105.80	25.99	2.88	2.07	155	2	87.4	1
MEX02NTE	-135.80	6	-107.36	26.32	3.80	1.57	149	2	87.4	1
MEX02SUR	-126.80	6	-96.39	19.88	3.19	1.87	158	2	87.4	1
PRU00004	-85.80	6	-74.19	-8.39	3.74	2.45	112	2	87.4	
PTRVIR01	-100.80	6	-93.85	36.31	8.26	3.55	171	2	87.4	1 6 9/GR20
PTRVIR02	-109.80	6	-95.47	36.38	8.10	3.45	168	2	87.4	1 6 9/GR21
TCA00001	-115.80	6	-71.79	21.53	0.60	0.60	90	2	87.4	
USAEH001	-61.30	6	-87.53	36.18	6.41	3.49	12	2	87.4	1 5 6
USAEH002	-100.80	6	-93.85	36.31	8.26	3.55	171	2	87.4	1 6 9/GR20
USAEH003	-109.80	6	-95.47	36.38	8.10	3.45	168	2	87.4	1 6 9/GR21
USAEH004	-118.80	6	-96.42	36.21	8.20	3.12	165	2	87.4	1 5 6
USAPSA02	-165.80	6	-109.83	36.82	6.03	1.12	137	2	87.4	9/GR1
USAPSA03	-174.80	6	-116.10	37.47	5.60	0.76	132	2	87.4	9/GR2
USAWH101	-147.80	6	-111.01	40.67	4.38	2.15	162	2	87.4	
USAWH102	-156.80	6	-113.01	40.71	3.74	1.79	149	2	87.4	
VCT00001	-79.30	6	-61.18	13.23	0.60	0.60	90	2	87.4	
VEN11VEN	-103.80	6	-66.79	6.90	2.50	1.77	122	2	87.4	

1	2	3	4		5		6	7	8	9
ALS00002	-166.20	7	-109.94	36.86	6.04	1.11	137	1	87.4	9/GR1
ALS00003	-175.20	7	-116.23	37.50	5.60	0.75	132	1	87.4	9/GR2
ARGINSU4	-94.20	7	-52.98	-59.81	3.40	0.68	19	1	87.4	9/GR3
ARGINSU5	-55.20	7	-44.17	-59.91	3.77	0.70	13	1	87.4	9/GR4
ARGSUR04	-94.20	7	-65.04	-43.33	3.32	1.50	40	1	87.4	9/GR3
ARGSUR05	-55.20	7	-63.68	-43.01	2.54	2.38	152	1	87.4	9/GR4
ATGSJN01	-79.70	7	-61.79	17.07	0.60	0.60	90	1	87.4	
B CE311	-64.20	7	-40.60	-6.07	3.04	2.06	174	1	87.4	8 9/GR7
B CE312	-45.20	7	-40.27	-6.06	3.44	2.09	174	1	87.4	8 9/GR9
B CE411	-64.20	7	-50.97	-15.27	3.86	1.38	49	1	87.4	8 9/GR7
B CE412	-45.20	7	-50.71	-15.30	3.57	1.56	52	1	87.4	8 9/GR9
B CE511	-64.20	7	-53.10	-2.90	2.44	2.13	104	1	87.4	8 9/GR7
B NO611	-74.20	7	-59.60	-11.62	2.85	1.69	165	2	87.4	8 9/GR8
B NO711	-74.20	7	-60.70	-1.78	3.54	1.78	126	2	87.4	8 9/GR8
B NO811	-74.20	7	-68.76	-4.71	2.37	1.65	73	2	87.4	8 9/GR8
B SU111	-81.20	7	-51.12	-25.63	2.76	1.05	50	1	87.4	8 9/GR6
B SU112	-45.20	7	-50.75	-25.62	2.47	1.48	56	1	87.4	8 9/GR9
B SU211	-81.20	7	-44.51	-16.95	3.22	1.36	60	1	87.4	8 9/GR6
B SU212	-45.20	7	-44.00	-16.87	3.20	1.96	58	1	87.4	8 9/GR9
BERBERMU	-96.20	7	-64.77	32.32	0.60	0.60	90	2	87.4	
BOLAND01	-115.20	7	-71.37	-4.69	6.49	2.57	87	1	87.4	9/GR5
BOL00001	-87.20	7	-64.61	-16.71	2.52	2.19	85	1	87.4	
BRB00001	-92.70	7	-59.85	12.93	0.60	0.60	90	2	87.4	
CAN01101	-138.20	7	-114.60	51.08	7.28	1.10	160	1	87.4	9/GR10
CAN01201	-138.20	7	-114.60	51.08	7.28	1.10	160	1	87.4	9/GR10
CAN01202	-72.70	7	-81.34	50.02	7.96	2.55	5	1	87.4	
CAN01203	-129.20	7	-113.02	51.08	7.47	1.26	162	1	87.4	9/GR12
CAN01303	-129.20	7	-113.02	51.08	7.47	1.26	162	1	87.4	9/GR12
CAN01304	-91.20	7	-86.71	50.48	8.58	2.54	178	1	87.4	9/GR13
CAN01403	-129.20	7	-113.02	51.08	7.47	1.26	162	1	87.4	9/GR12
CAN01404	-91.20	7	-86.71	50.48	8.58	2.54	178	1	87.4	9/GR13
CAN01405	-82.20	7	-84.11	50.20	8.31	2.58	1	1	87.4	9/GR14
CAN01504	-91.20	7	-86.71	50.48	8.58	2.54	178	1	87.4	9/GR13
CAN01505	-82.20	7	-84.11	50.20	8.31	2.58	1	1	87.4	9/GR14
CAN01605	-82.20	7	-84.11	50.20	8.31	2.58	1	1	87.4	9/GR14
CAN01606	-70.70	7	-80.77	50.03	7.88	2.53	6	1	87.4	
CHLCONT5	-106.20	7	-72.23	-35.57	2.60	0.68	55	1	87.4	9/GR17
CHLPAC02	-106.20	7	-80.06	-30.06	1.36	0.68	69	1	87.4	9/GR17
CLMAND01	-115.20	7	-71.37	-4.69	6.49	2.57	87	1	87.4	9/GR5
CLM00001	-103.20	7	-74.50	5.87	3.98	1.96	118	1	87.4	
CUB00001	-89.20	7	-79.81	21.62	2.24	0.68	168	1	87.4	
EQACAND1	-115.20	7	-71.37	-4.69	6.49	2.57	87	1	87.4	9/GR5
EQAGAND1	-115.20	7	-71.37	-4.69	6.49	2.57	87	1	87.4	9/GR5
GRD00002	-42.20	7	-61.58	12.29	0.60	0.60	90	1	87.4	
GRD00059	-57.20	7	-61.58	12.29	0.60	0.60	90	1	87.4	
GRLDNK01	-53.20	7	-44.89	66.56	2.70	0.82	173	1	87.4	2
HWA00002	-166.20	7	-109.94	36.86	6.04	1.11	137	1	87.4	9/GR1
HWA00003	-175.20	7	-116.23	37.50	5.60	0.75	132	1	87.4	9/GR2
MEX01NTE	-78.20	7	-105.81	26.01	2.89	2.08	155	1	87.4	1
MEX01SUR	-69.20	7	-94.84	19.82	3.05	2.09	4	1	87.4	1
MEX02NTE	-136.20	7	-107.21	26.31	3.84	1.55	148	1	87.4	1
MEX02SUR	-127.20	7	-96.39	19.88	3.18	1.87	157	1	87.4	1
PAQPAC01	-106.20	7	-109.18	-27.53	0.60	0.60	90	1	87.4	9/GR17
PRG00002	-99.20	7	-58.66	-23.32	1.45	1.04	76	1	87.4	
PRUAND02	-115.20	7	-71.37	-4.69	6.49	2.57	87	1	87.4	9/GR5
PTRVIR01	-101.20	7	-93.94	36.32	8.24	3.56	171	1	87.4	1 6 9/GR20
PTRVIR02	-110.20	7	-95.23	36.29	8.27	3.37	168	1	87.4	1 6 9/GR21
SURINAM2	-84.70	7	-55.69	4.35	1.00	0.69	86	1	87.4	
URG00001	-71.70	7	-56.22	-32.52	1.02	0.89	11	1	87.4	
USAEH001	-61.70	7	-87.57	36.17	6.42	3.49	12	1	87.4	1 5 6
USAEH002	-101.20	7	-93.94	36.32	8.24	3.56	171	1	87.4	1 6 9/GR20
USAEH003	-110.20	7	-95.23	36.29	8.27	3.37	168	1	87.4	1 6 9/GR21
USAEH004	-119.20	7	-96.45	36.21	8.20	3.12	165	1	87.4	1 5 6
USAPSA02	-166.20	7	-109.94	36.86	6.04	1.11	137	1	87.4	9/GR1
USAPSA03	-175.20	7	-116.23	37.50	5.60	0.75	132	1	87.4	9/GR2
USAWH101	-148.20	7	-111.02	40.68	4.36	2.15	162	1	87.4	
USAWH102	-157.20	7	-113.07	40.74	3.72	1.78	149	1	87.4	
VENAND03	-115.20	7	-71.37	-4.69	6.49	2.57	87	1	87.4	9/GR5

17 426.06 MHz (8)

1	2	3	4	5	6	7	8	9		
ALS00002	-165.80	8	-109.83	36.82	6.03	1.12	137	2	87.4	9/GR1
ALS00003	-174.80	8	-116.10	37.47	5.60	0.76	132	2	87.4	9/GR2
ARGNORT4	-93.80	8	-63.96	-30.01	3.86	1.99	48	2	87.4	
ARGNORT5	-54.80	8	-62.85	-29.80	3.24	2.89	47	2	87.4	
B CE311	-63.80	8	-40.60	-6.07	3.04	2.06	174	2	87.4	8 9/GR7
B CE312	-44.80	8	-40.26	-6.06	3.44	2.09	174	2	87.4	8 9/GR9
B CE411	-63.80	8	-50.97	-15.26	3.86	1.38	49	2	87.4	8 9/GR7
B CE412	-44.80	8	-50.71	-15.30	3.57	1.56	52	2	87.4	8 9/GR9
B CE511	-63.80	8	-53.11	-2.98	2.42	2.15	107	2	87.4	8 9/GR7
B NO611	-73.80	8	-59.60	-11.62	2.86	1.69	165	1	87.4	8 9/GR8
B NO711	-73.80	8	-60.70	-1.78	3.54	1.78	126	1	87.4	8 9/GR8
B NOR11	-73.80	8	-68.75	-4.71	2.37	1.65	73	1	87.4	8 9/GR8
B SE911	-101.80	8	-45.99	-19.09	2.22	0.79	62	2	87.4	8
B SU111	-80.80	8	-51.10	-25.64	2.76	1.06	50	2	87.4	8 9/GR6
B SU112	-44.80	8	-50.76	-25.62	2.47	1.48	56	2	87.4	8 9/GR9
B SU211	-80.80	8	-44.51	-16.94	3.22	1.37	60	2	87.4	8 9/GR6
B SU212	-44.80	8	-43.99	-16.97	3.27	1.92	59	2	87.4	8 9/GR9
CAN01101	-137.80	8	-114.10	50.92	7.22	1.11	160	2	87.4	9/GR10
CAN01201	-137.80	8	-114.10	50.92	7.22	1.11	160	2	87.4	9/GR10
CAN01202	-72.30	8	-81.23	50.12	7.99	2.53	5	2	87.4	
CAN01203	-128.80	8	-113.04	51.04	7.53	1.26	162	2	87.4	9/GR12
CAN01303	-128.80	8	-113.04	51.04	7.53	1.26	162	2	87.4	9/GR12
CAN01304	-90.80	8	-86.57	50.48	8.59	2.54	178	2	87.4	9/GR13
CAN01403	-128.80	8	-113.04	51.04	7.53	1.26	162	2	87.4	9/GR12
CAN01404	-90.80	8	-86.57	50.48	8.59	2.54	178	2	87.4	9/GR13
CAN01405	-81.80	8	-83.80	50.22	8.35	2.57	2	2	87.4	9/GR14
CAN01504	-90.80	8	-86.57	50.48	8.59	2.54	178	2	87.4	9/GR13
CAN01505	-81.80	8	-83.80	50.22	8.35	2.57	2	2	87.4	9/GR14
CAN01605	-81.80	8	-83.80	50.22	8.35	2.57	2	2	87.4	9/GR14
CAN01606	-70.30	8	-80.64	50.02	7.88	2.52	6	2	87.4	
CHLCONT4	-105.80	8	-69.59	-23.20	2.21	0.69	68	2	87.4	9/GR16
CHLCONT6	-105.80	8	-73.52	-55.52	3.65	1.31	39	2	87.4	9/GR16
CRBBAH01	-92.30	8	-76.09	24.13	1.83	0.68	141	1	87.4	9/GR18
CRBBER01	-92.30	8	-64.76	32.13	0.60	0.60	90	1	87.4	9/GR18
CRBBLZ01	-92.30	8	-88.61	17.26	0.64	0.64	90	1	87.4	9/GR18
CRBEC001	-92.30	8	-60.07	8.26	4.20	0.86	115	1	87.4	9/GR18
CRBJMC01	-92.30	8	-79.45	17.97	0.99	0.68	151	1	87.4	9/GR18
CYM00001	-115.80	8	-80.58	19.57	0.60	0.60	90	2	87.4	
DOMIFRB2	-83.30	8	-70.51	18.79	0.98	0.69	167	2	87.4	
EQAC0001	-94.80	8	-78.31	-1.52	1.48	1.15	65	1	87.4	9/GR19
EQAG0001	-94.80	8	-90.36	-0.57	0.94	0.89	99	1	87.4	9/GR19
GUFMGG02	-52.80	8	-56.42	8.47	4.16	0.81	123	2	87.4	2 7
HWA00002	-165.80	8	-109.83	36.82	6.03	1.12	137	2	87.4	9/GR1
HWA00003	-174.80	8	-116.10	37.47	5.60	0.76	132	2	87.4	9/GR2
JMC00005	-33.80	8	-77.27	18.12	0.60	0.60	90	2	87.4	
LCAIFRB1	-79.30	8	-61.15	13.90	0.60	0.60	90	2	87.4	
MEX01NTE	-77.80	8	-105.80	25.99	2.88	2.07	155	2	87.4	1
MEX02NTE	-135.80	8	-107.36	26.32	3.80	1.57	149	2	87.4	1
MEX02SUR	-126.80	8	-96.39	19.88	3.19	1.87	158	2	87.4	1
PRU00004	-85.80	8	-74.19	-8.39	3.74	2.45	112	2	87.4	
PTRVIR01	-100.80	8	-93.85	36.31	8.26	3.55	171	2	87.4	1 6 9/GR20
PTRVIR02	-109.80	8	-93.85	36.38	8.10	3.45	168	2	87.4	1 6 9/GR21
SLVIFRB2	-107.30	8	-88.91	13.59	0.60	0.60	90	1	87.4	
USAEH001	-61.30	8	-87.53	36.18	6.41	3.49	12	2	87.4	1 5 6
USAEH002	-100.80	8	-93.85	36.31	8.26	3.55	71	2	87.4	1 6 9/GR20
USAEH003	-109.80	8	-95.47	36.38	8.10	3.45	168	2	87.4	1 6 9/GR21
USAEH004	-118.80	8	-96.42	36.21	8.20	3.12	165	2	87.4	1 5 6
USAPSA02	-165.80	8	-109.83	36.82	6.03	1.12	137	2	87.4	9/GR1
USAPSA03	-174.80	8	-116.10	37.47	5.60	0.76	132	2	87.4	9/GR2
USAWH101	-147.80	8	-111.01	40.67	4.38	2.15	162	2	87.4	
USAWH102	-156.80	8	-113.01	40.71	3.74	1.79	149	2	87.4	
VEN11VEN	-103.80	8	-66.79	6.90	2.50	1.77	122	2	87.4	



1	2	3	4	5	6	7	8	9		
ALS00002	-166.20	9	-109.94	36.86	6.04	1.11	137	1	87.4	9/GR1
ALS00003	-175.20	9	-116.23	37.50	5.60	0.75	132	1	87.4	9/GR2
ARGINSU4	-94.20	9	-52.98	-59.81	3.40	0.68	19	1	87.4	9/GR3
ARGSUR04	-94.20	9	-65.04	-43.33	3.32	1.50	40	1	87.4	9/GR3
B CE311	-64.20	9	-40.60	-6.07	3.04	2.06	174	1	87.4	8/9/GR7
B CE312	-45.20	9	-40.27	-6.06	3.44	2.09	174	1	87.4	8/9/GR9
B CE411	-64.20	9	-50.97	-15.27	3.86	1.38	49	1	87.4	8/9/GR7
B CE412	-45.20	9	-50.71	-15.30	3.57	1.56	52	1	87.4	8/9/GR9
B CE511	-64.20	9	-53.10	-2.90	2.44	2.13	104	1	87.4	8/9/GR7
B NO611	-74.20	9	-59.60	-11.62	2.85	1.69	165	2	87.4	8/9/GR8
B NO711	-74.20	9	-60.70	-1.78	3.54	1.78	126	2	87.4	8/9/GR8
B NO811	-74.20	9	-68.76	-4.71	2.37	1.65	73	2	87.4	8/9/GR8
B SU111	-81.20	9	-51.12	-25.63	2.76	1.05	50	1	87.4	8/9/GR6
B SU112	-45.20	9	-50.75	-25.62	2.47	1.48	56	1	87.4	8/9/GR9
B SU211	-81.20	9	-44.51	-16.95	3.22	1.36	60	1	87.4	8/9/GR6
B SU212	-45.20	9	-44.00	-16.87	3.20	1.96	58	1	87.4	8/9/GR9
BAHIFRB1	-87.20	9	-76.06	24.16	1.81	0.70	142	1	87.4	
BERBERMU	-96.20	9	-64.77	32.32	0.60	0.60	90	2	87.4	
BERBER02	-31.00	9	-64.77	32.32	0.60	0.60	90	1	87.4	2 3
BOLAND01	-115.20	9	-71.37	-4.69	6.49	2.57	87	1	87.4	9/GR5
CAN01101	-138.20	9	-114.60	51.08	7.28	1.10	160	1	87.4	9/GR10
CAN01201	-138.20	9	-114.60	51.08	7.28	1.10	160	1	87.4	9/GR10
CAN01202	-72.70	9	-81.34	50.02	7.96	2.55	5	1	87.4	
CAN01203	-129.20	9	-113.02	51.08	7.47	1.26	162	1	87.4	9/GR12
CAN01303	-129.20	9	-113.02	51.08	7.47	1.26	162	1	87.4	9/GR12
CAN01304	-91.20	9	-86.71	50.48	8.58	2.54	178	1	87.4	9/GR13
CAN01403	-129.20	9	-113.02	51.08	7.47	1.26	162	1	87.4	9/GR12
CAN01404	-91.20	9	-86.71	50.48	8.58	2.54	178	1	87.4	9/GR13
CAN01405	-82.20	9	-84.11	50.20	8.31	2.58	1	1	87.4	9/GR14
CAN01504	-91.20	9	-86.71	50.48	8.58	2.54	178	1	87.4	9/GR13
CAN01505	-82.20	9	-84.11	50.20	8.31	2.58	1	1	87.4	9/GR14
CAN01605	-82.20	9	-84.11	50.20	8.31	2.58	1	1	87.4	9/GR14
CAN01606	-70.70	9	-80.77	50.03	7.88	2.53	6	1	87.4	
CHLCONT5	-106.20	9	-72.23	-35.57	2.60	0.68	55	1	87.4	9/GR17
CHLPAC02	-106.20	9	-80.06	-30.06	1.36	0.68	69	1	87.4	9/GR17
CLMAND01	-115.20	9	-71.37	-4.69	6.49	2.57	87	1	87.4	9/GR5
CLM00001	-103.20	9	-74.50	5.87	3.98	1.96	118	1	87.4	
EQACAND1	-115.20	9	-71.37	-4.69	6.49	2.57	87	1	87.4	9/GR5
EQACAND1	-115.20	9	-71.37	-4.69	6.49	2.57	87	1	87.4	9/GR5
FLKANT01	-57.20	9	-44.54	-60.13	3.54	0.68	12	1	87.4	2
FLKFALKS	-31.00	9	-59.90	-51.64	0.60	0.60	90	1	87.4	2 3
GRD00002	-42.20	9	-61.58	12.29	0.60	0.60	90	1	87.4	
HWA00002	-166.20	9	-109.94	36.86	6.04	1.11	137	1	87.4	9/GR1
HWA00003	-175.20	9	-116.23	37.50	5.60	0.75	132	1	87.4	9/GR2
MEX01NTE	-78.20	9	-105.81	26.01	2.89	2.08	155	1	87.4	1
MEX01SUR	-69.20	9	-94.84	19.82	3.05	2.09	4	1	87.4	1
MEX02NTE	-136.20	9	-107.21	26.31	3.84	1.55	148	1	87.4	1
MEX02SUR	-127.20	9	-96.39	19.88	3.18	1.87	157	1	87.4	1
PAQPAC01	-106.20	9	-109.18	-27.53	0.60	0.60	90	1	87.4	9/GR17
PRG00002	-99.20	9	-58.66	-23.32	1.45	1.04	76	1	87.4	
PRUAND02	-115.20	9	-71.37	-4.69	6.49	2.57	87	1	87.4	9/GR5
PTRVIR01	-101.20	9	-93.94	36.32	8.24	3.56	171	1	87.4	1 6 9/GR20
PTRVIR02	-110.20	9	-95.23	36.29	8.27	3.37	168	1	87.4	1 6 9/GR21
SPMFRAN3	-53.20	9	-67.24	47.51	3.16	0.79	7	1	87.4	2 7
TRD00001	-84.70	9	-61.23	10.70	0.60	0.60	90	1	87.4	
URG00001	-71.70	9	-56.22	-32.52	1.02	0.89	11	1	87.4	
USAEH001	-61.70	9	-87.57	36.17	6.42	3.49	12	1	87.4	1 5 6
USAEH002	-101.20	9	-93.94	36.32	8.24	3.56	171	1	87.4	1 6 9/GR20
USAEH003	-110.20	9	-95.23	36.29	8.27	3.37	168	1	87.4	1 6 9/GR21
USAEH004	-119.20	9	-96.45	36.21	8.20	3.12	165	1	87.4	1 5 6
USAPSA02	-166.20	9	-109.94	36.86	6.04	1.11	137	1	87.4	9/GR1
USAPSA03	-175.20	9	-116.23	37.50	5.60	0.75	132	1	87.4	9/GR2
USAWH01	-148.20	9	-111.02	40.68	4.36	2.15	162	1	87.4	
USAWH102	-157.20	9	-113.07	40.74	3.72	1.78	149	1	87.4	
VENAND03	-115.20	9	-71.37	-4.69	6.49	2.57	87	1	87.4	9/GR5
VRG00001	-79.70	9	-64.37	18.48	0.60	0.60	90	1	87.4	4

17 455.22 MHz (10)

1	2	3	4	5	6	7	8	9		
ALS00002	-165.80	10	-109.83	36.82	6.03	1.12	137	2	87.4	9/GR1
ALS00003	-174.80	10	-116.10	37.47	5.60	0.76	132	2	87.4	9/GR2
ARGNORT4	-93.80	10	-63.96	-30.01	3.86	1.99	48	2	87.4	
ARGNORT5	-54.80	10	-62.85	-29.80	3.24	2.89	47	2	87.4	
ATNBEM1	-52.80	10	-66.44	14.87	1.83	0.68	39	2	87.4	
B CE311	-63.80	10	-40.60	-6.07	3.04	2.06	174	2	87.4	8 9/GR7
B CE312	-44.80	10	-40.26	-6.06	3.44	2.09	174	2	87.4	8 9/GR9
B CE411	-63.80	10	-50.97	-15.26	3.86	1.38	49	2	87.4	8 9/GR7
B CE412	-44.80	10	-50.71	-15.30	3.57	1.56	52	2	87.4	8 9/GR9
B CE511	-63.80	10	-53.11	-2.98	2.42	2.15	107	2	87.4	8 9/GR7
B NO611	-73.80	10	-59.60	-11.62	2.86	1.69	165	1	87.4	8 9/GR8
B NO711	-73.80	10	-60.70	-1.78	3.54	1.78	126	1	87.4	8 9/GR8
B NO811	-73.80	10	-68.75	-4.71	2.37	1.65	73	1	87.4	8 9/GR8
B SE911	-101.80	10	-45.99	-19.09	2.22	0.79	62	2	87.4	8
B SU111	-80.80	10	-51.10	-25.64	2.76	1.06	50	2	87.4	8 9/GR6
B SU112	-44.80	10	-50.76	-25.62	2.47	1.48	56	2	87.4	8 9/GR9
B SU211	-80.80	10	-44.51	-16.94	3.22	1.37	60	2	87.4	8 9/GR6
B SU212	-44.80	10	-43.99	-16.97	3.27	1.92	59	2	87.4	8 9/GR9
CAN01101	-137.80	10	-114.10	50.92	7.22	1.11	160	2	87.4	9/GR10
CAN01201	-137.80	10	-114.10	50.92	7.22	1.11	160	2	87.4	9/GR10
CAN01202	-72.30	10	-81.23	50.12	7.99	2.53	5	2	87.4	
CAN01203	-128.80	10	-113.04	51.04	7.53	1.26	162	2	87.4	9/GR12
CAN01303	-128.80	10	-113.04	51.04	7.53	1.26	162	2	87.4	9/GR12
CAN01304	-90.80	10	-86.57	50.48	8.59	2.54	178	2	87.4	9/GR13
CAN01403	-128.80	10	-113.04	51.04	7.53	1.26	162	2	87.4	9/GR12
CAN01404	-90.80	10	-86.57	50.48	8.59	2.54	178	2	87.4	9/GR13
CAN01405	-81.80	10	-83.80	50.22	8.35	2.57	2	2	87.4	9/GR14
CAN01504	-90.80	10	-86.57	50.48	8.59	2.54	178	2	87.4	9/GR13
CAN01505	-81.80	10	-83.80	50.22	8.35	2.57	2	2	87.4	9/GR14
CAN01605	-81.80	10	-83.80	50.22	8.35	2.57	2	2	87.4	9/GR14
CAN01606	-70.30	10	-80.64	50.02	7.88	2.52	6	2	87.4	
CHLCONT4	-105.80	10	-69.59	-23.20	2.21	0.69	68	2	87.4	9/GR16
CHLCONH6	-105.80	10	-73.52	-55.52	3.65	1.31	39	2	87.4	9/GR16
CRBBA071	-92.30	10	-76.09	24.13	1.83	0.68	141	1	87.4	9/GR18
CRBBER01	-92.30	10	-64.76	32.13	0.60	0.60	90	1	87.4	9/GR18
CRBBLZ01	-92.30	10	-88.61	17.26	0.64	0.64	90	1	87.4	9/GR18
CRBEC001	-92.30	10	-60.07	8.26	4.20	0.86	115	1	87.4	9/GR18
CRBJMCO1	-92.30	10	-79.45	17.97	0.99	0.68	151	1	87.4	9/GR18
CTRO0201	-130.80	10	-84.33	9.67	0.82	0.68	119	2	87.4	
EQAC0001	-94.80	10	-78.31	-1.52	1.48	1.15	65	1	87.4	9/GR19
EQAG0001	-94.80	10	-90.36	-0.57	0.94	0.89	99	1	87.4	9/GR19
GUY00302	-33.80	10	-59.07	4.77	1.43	0.85	91	2	87.4	
HNDIFRB2	-107.30	10	-86.23	15.16	1.14	0.85	8	1	87.4	
HTI00002	-83.30	10	-73.28	18.96	0.82	0.68	11	2	87.4	
HWA00002	-165.80	10	-109.83	36.82	6.03	1.12	137	2	87.4	9/GR1
HWA00003	-174.80	10	-116.10	37.47	5.60	0.76	132	2	87.4	9/GR2
MEX01NTE	-77.80	10	-105.80	25.99	2.88	2.07	155	2	87.4	1
MEX02NTE	-135.80	10	-107.36	26.32	3.80	1.57	149	2	87.4	1
MEX02SUR	-126.80	10	-96.39	19.88	3.19	1.87	158	2	87.4	1
PRU00004	-85.80	10	-74.19	-8.39	3.74	2.45	112	2	87.4	
PTRVIR01	-100.80	10	-93.85	36.31	8.26	3.55	171	2	87.4	1 6 9/GR20
PTRVIR02	-109.80	10	-95.47	36.38	8.10	3.45	168	2	87.4	1 6 9/GR21
TCA00001	-115.80	10	-71.79	21.53	0.60	0.60	90	2	87.4	
USAEH001	-61.30	10	-87.53	36.18	6.41	3.49	12	2	87.4	1 5 6
USAEH002	-100.80	10	-93.85	36.31	8.26	3.55	171	2	87.4	1 6 9/GR20
USAEH003	-109.80	10	-95.47	36.38	8.10	3.45	168	2	87.4	1 6 9/GR21
USAEH004	-118.80	10	-96.42	36.21	8.20	3.12	165	2	87.4	1 5 6
USAPSA02	-165.80	10	-109.83	36.82	6.03	1.12	137	2	87.4	9/GR1
USAPSA03	-174.80	10	-116.10	37.47	5.60	0.76	132	2	87.4	9/GR2
USAWH101	-147.80	10	-111.01	40.67	4.38	2.15	162	2	87.4	
USAWH102	-156.80	10	-113.01	40.71	3.74	1.79	149	2	87.4	
VCT00001	-79.30	10	-61.18	13.23	0.60	0.60	90	2	87.4	
VEN11VEN	-103.80	10	-66.79	6.90	2.50	1.77	122	2	87.4	

1	2	3	4		5		6	7	8	9
ALS00002	-166.20	11	-109.94	36.86	6.04	1.11	137	1	87.4	9/GR1
ALS00003	-175.20	11	-116.23	37.50	5.60	0.75	132	1	87.4	9/GR2
ARGINSU4	-94.20	11	-52.98	-59.81	3.40	0.68	19	1	87.4	9/GR3
ARGINSU5	-55.20	11	-44.17	-59.91	3.77	0.70	13	1	87.4	9/GR4
ARGSUR04	-94.20	11	-65.04	-43.33	3.32	1.50	40	1	87.4	9/GR3
ARGSUR05	-55.20	11	-63.68	-43.01	2.54	2.38	152	1	87.4	9/GR4
ATGSJN01	-79.70	11	-61.79	17.07	0.60	0.60	90	1	87.4	
B CE311	-64.20	11	-40.60	-6.07	3.04	2.06	174	1	87.4	8 9/GR7
B CE312	-45.20	11	-40.27	-6.06	3.44	2.09	174	1	87.4	8 9/GR9
B CE411	-64.20	11	-50.97	-15.27	3.86	1.38	49	1	87.4	8 9/GR7
B CE412	-45.20	11	-50.71	-15.30	3.57	1.56	52	1	87.4	8 9/GR9
B CE511	-64.20	11	-53.10	-2.90	2.44	2.13	104	1	87.4	8 9/GR7
B NO611	-74.20	11	-59.60	-11.62	2.85	1.69	165	2	87.4	8 9/GR8
B NO711	-74.20	11	-60.70	-1.78	3.54	1.78	126	2	87.4	8 9/GR8
B NO811	-74.20	11	-68.76	-4.71	2.37	1.65	73	2	87.4	8 9/GR8
B SU111	-81.20	11	-51.12	-25.63	2.76	1.05	50	1	87.4	8 9/GR6
B SU112	-45.20	11	-50.75	-25.62	2.47	1.48	56	1	87.4	8 9/GR9
B SU211	-81.20	11	-44.51	-16.95	3.22	1.36	60	1	87.4	8 9/GR6
B SU212	-45.20	11	-44.00	-16.87	3.20	1.96	58	1	87.4	8 9/GR9
BERBERMU	-96.20	11	-64.77	32.32	0.60	0.60	90	2	87.4	
BOLAND01	-115.20	11	-71.37	-4.69	6.49	2.57	87	1	87.4	9/GR5
BOL00001	-87.20	11	-64.61	-16.71	2.52	2.19	85	1	87.4	
BRB00001	-92.70	11	-59.85	12.93	0.60	0.60	90	2	87.4	
CAN01101	-138.20	11	-114.60	51.08	7.28	1.10	160	1	87.4	9/GR10
CAN01201	-138.20	11	-114.60	51.08	7.28	1.10	160	1	87.4	9/GR10
CAN01202	-72.70	11	-81.34	50.02	7.96	2.55	5	1	87.4	
CAN01203	-129.20	11	-113.02	51.08	7.47	1.26	162	1	87.4	9/GR12
CAN01303	-129.20	11	-113.02	51.08	7.47	1.26	162	1	87.4	9/GR12
CAN01304	-91.20	11	-86.71	50.48	8.58	2.54	178	1	87.4	9/GR13
CAN01403	-129.20	11	-113.02	51.08	7.47	1.26	162	1	87.4	9/GR12
CAN01404	-91.20	11	-86.71	50.48	8.58	2.54	178	1	87.4	9/GR13
CAN01405	-82.20	11	-84.11	50.20	8.31	2.58	1	1	87.4	9/GR14
CAN01504	-91.20	11	-86.71	50.48	8.58	2.54	178	1	87.4	9/GR13
CAN01505	-82.20	11	-84.11	50.20	8.31	2.58	1	1	87.4	9/GR14
CAN01605	-82.20	11	-84.11	50.20	8.31	2.58	1	1	87.4	9/GR14
CAN01606	-70.70	11	-80.77	50.03	7.88	2.53	6	1	87.4	
CHLCONT5	-106.20	11	-72.23	-35.57	2.60	0.68	55	1	87.4	9/GR17
CHLPAC02	-106.20	11	-80.06	-30.06	1.36	0.68	69	1	87.4	9/GR17
CLMAND01	-115.20	11	-71.37	-4.69	6.49	2.57	87	1	87.4	9/GR5
CLM00001	-103.20	11	-74.50	5.87	3.98	1.96	118	1	87.4	
CUB00001	-89.20	11	-79.81	21.62	2.24	0.68	168	1	87.4	
EQACAND1	-115.20	11	-71.37	-4.69	6.49	2.57	87	1	87.4	9/GR5
EQAGAND1	-115.20	11	-71.37	-4.69	6.49	2.57	87	1	87.4	9/GR5
GRD00002	-42.20	11	-61.58	12.29	0.60	0.60	90	1	87.4	
GRD00059	-57.20	11	-61.58	12.29	0.60	0.60	90	1	87.4	
GRLDNK01	-53.20	11	-44.89	66.56	2.70	0.82	173	1	87.4	2
GUY0201	-84.70	11	-59.19	4.78	1.44	0.85	95	1	87.4	
HWA00002	-166.20	11	-109.94	36.86	6.04	1.11	137	1	87.4	9/GR1
HWA00003	-175.20	11	-116.23	37.50	5.60	0.75	132	1	87.4	9/GR2
MEX01NTE	-78.20	11	-105.81	26.01	2.89	2.08	155	1	87.4	1
MEX01SUR	-69.20	11	-94.84	19.82	3.05	2.09	4	1	87.4	1
MEX02NTE	-136.20	11	-107.21	26.31	3.84	1.55	148	1	87.4	1
MEX02SUR	-127.20	11	-96.39	19.88	3.18	1.87	157	1	87.4	1
PAQAC01	-106.20	11	-109.18	-27.53	0.60	0.60	90	1	87.4	9/GR17
PRG00002	-99.20	11	-58.66	-23.32	1.45	1.04	76	1	87.4	
PRUAND02	-115.20	11	-71.37	-4.69	6.49	2.57	87	1	87.4	9/GR5
PTRVIR01	-101.20	11	-93.94	36.32	8.24	3.56	171	1	87.4	1 6 9/GR20
PTRVIR02	-110.20	11	-95.23	36.29	8.27	3.37	168	1	87.4	1 6 9/GR21
URG00001	-71.70	11	-56.22	-32.52	1.02	0.89	11	1	87.4	
USAEH001	-61.70	11	-87.57	36.17	6.42	3.49	12	1	87.4	1 5 6
USAEH002	-101.20	11	-93.94	36.32	8.24	3.56	171	1	87.4	1 6 9/GR20
USAEH003	-110.20	11	-95.23	36.29	8.27	3.37	168	1	87.4	1 6 9/GR21
USAEH004	-119.20	11	-96.45	36.21	8.20	3.12	165	1	87.4	1 5 6
USAPSA02	-166.20	11	-109.94	36.86	6.04	1.11	137	1	87.4	9/GR1
USAPSA03	-175.20	11	-116.23	37.50	5.60	0.75	132	1	87.4	9/GR2
USAWH101	-148.20	11	-111.02	40.68	4.36	2.15	162	1	87.4	
USAWH102	-157.20	11	-113.07	40.74	3.72	1.78	149	1	87.4	
VENAND03	-115.20	11	-71.37	-4.69	6.49	2.57	87	1	87.4	9/GR5

17 484.38 MHz (12)

1	2	3	4	5	6	7	8	9		
ALS00002	-165.80	12	-109.83	36.82	6.03	1.12	137	2	87.4	9/GR1
ALS00003	-174.80	12	-116.10	37.47	5.60	0.76	132	2	87.4	9/GR2
ARGNORT4	-93.80	12	-63.96	-30.01	3.86	1.99	48	2	87.4	
ARGNORT5	-54.80	12	-62.85	-29.80	3.24	2.89	47	2	87.4	
B CE311	-63.80	12	-40.60	-6.07	3.04	2.06	174	2	87.4	8 9/GR7
B CE312	-44.80	12	-40.26	-6.06	3.44	2.09	174	2	87.4	8 9/GR9
B CE411	-63.80	12	-50.97	-15.26	3.86	1.38	49	2	87.4	8 9/GR7
B CE412	-44.80	12	-50.71	-15.30	3.57	1.56	52	2	87.4	8 9/GR9
B CE511	-63.80	12	-53.11	-2.98	2.42	2.15	107	2	87.4	8 9/GR7
B NO611	-73.80	12	-59.60	-11.62	2.86	1.69	165	1	87.4	8 9/GR8
B NO711	-73.80	12	-60.70	-1.78	3.54	1.78	126	1	87.4	8 9/GR8
B NO811	-73.80	12	-68.75	-4.71	2.37	1.65	73	1	87.4	8 9/GR8
B SE911	-101.80	12	-45.99	-19.09	2.22	0.79	62	2	87.4	8
B SU111	-80.80	12	-51.10	-25.64	2.76	1.06	50	2	87.4	8 9/GR6
B SU112	-44.80	12	-50.76	-25.62	2.47	1.48	56	2	87.4	8 9/GR9
B SU211	-80.80	12	-44.51	-16.94	3.22	1.37	60	2	87.4	8 9/GR6
B SU212	-44.80	12	-43.99	-16.97	3.27	1.92	59	2	87.4	8 9/GR9
CAN01101	-137.80	12	-114.10	50.92	7.22	1.11	160	2	87.4	9/GR10
CAN01201	-137.80	12	-114.10	50.92	7.22	1.11	160	2	87.4	9/GR10
CAN01202	-72.30	12	-81.23	50.12	7.99	2.53	5	2	87.4	
CAN01203	-128.80	12	-113.04	51.04	7.53	1.26	162	2	87.4	9/GR12
CAN01303	-128.80	12	-113.04	51.04	7.53	1.26	162	2	87.4	9/GR12
CAN01304	-90.80	12	-86.57	50.48	8.58	2.54	178	2	87.4	9/GR13
CAN01403	-128.80	12	-113.04	51.04	7.53	1.26	162	2	87.4	9/GR12
CAN01404	-90.80	12	-86.57	50.48	8.59	2.54	178	2	87.4	9/GR13
CAN01405	-81.80	12	-83.80	50.22	8.35	2.57	2	2	87.4	9/GR14
CAN01504	-90.80	12	-86.57	50.48	8.59	2.54	178	2	87.4	9/GR13
CAN01505	-81.80	12	-83.80	50.22	8.35	2.57	2	2	87.4	9/GR14
CAN01605	-81.80	12	-83.80	50.22	8.35	2.57	2	2	87.4	9/GR14
CAN01606	-70.30	12	-80.64	50.02	7.88	2.52	6	2	87.4	
CHLCONT4	-105.80	12	-69.59	-23.20	2.21	0.69	68	2	87.4	9/GR16
CHLCONT6	-105.80	12	-73.52	-55.52	3.65	1.31	39	2	87.4	9/GR16
CRBBAH01	-92.30	12	-76.09	24.13	1.83	0.68	141	1	87.4	9/GR18
CRBBER01	-92.30	12	-64.76	32.13	0.60	0.60	90	1	87.4	9/GR18
CRBBLZ01	-92.30	12	-88.61	17.26	0.64	0.64	90	1	87.4	9/GR18
CRBEC001	-92.30	12	-60.07	8.26	4.20	0.86	115	1	87.4	9/GR18
CRBJMC01	-92.30	12	-79.45	17.97	0.99	0.68	151	1	87.4	9/GR18
CYM00001	-115.80	12	-80.58	19.57	0.60	0.60	90	2	87.4	
DOMIFRB2	-83.30	12	-70.51	18.79	0.98	0.69	167	2	87.4	
EQAC0001	-94.80	12	-78.31	-1.52	1.48	1.15	65	1	87.4	9/GR19
EQAG0001	-94.80	12	-90.36	-0.57	0.94	0.89	99	1	87.4	9/GR19
GUFMGG02	-52.80	12	-56.42	8.47	4.16	0.81	123	2	87.4	2 7
HWA00002	-165.80	12	-109.83	36.82	6.03	1.12	137	2	87.4	9/GR1
HWA00003	-174.80	12	-116.10	37.47	5.60	0.76	132	2	87.4	9/GR2
JMC00005	-33.80	12	-77.27	18.12	0.60	0.60	90	2	87.4	
LCAIFRB1	-79.30	12	-61.15	13.90	0.60	0.60	90	2	87.4	
MEX01NTE	-77.80	12	-105.80	25.99	2.88	2.07	155	2	87.4	1
MEX02NTE	-135.80	12	-107.36	26.32	3.80	1.57	149	2	87.4	1
MEX02SUR	-126.80	12	-96.39	19.88	3.19	1.87	158	2	87.4	1
PRU00004	-85.80	12	-74.19	-8.39	3.74	2.45	112	2	87.4	
PTRVIR01	-100.80	12	-93.85	36.31	8.26	3.55	171	2	87.4	1 6 9/GR20
PTRVIR02	-109.80	12	-95.47	36.38	8.10	3.45	168	2	87.4	1 6 9/GR21
SLVIFRB2	-107.30	12	-88.91	13.59	0.60	0.60	90	1	87.4	
USAEH001	-61.30	12	-87.53	36.18	6.41	3.49	12	2	87.4	1 5 6
USAEH002	-100.80	12	-93.85	36.31	8.26	3.55	171	2	87.4	1 6 9/GR20
USAEH003	-109.80	12	-95.47	36.38	8.10	3.45	168	2	87.4	1 6 9/GR21
USAEH004	-118.80	12	-96.42	36.21	8.20	3.12	165	2	87.4	1 5 6
USAPSA02	-165.80	12	-109.83	36.82	6.03	1.12	137	2	87.4	9/GR1
USAPSA03	-174.80	12	-116.10	37.47	5.60	0.76	132	2	87.4	9/GR2
USAWH101	-147.80	12	-111.01	40.67	4.38	2.15	162	2	87.4	
USAWH102	-156.80	12	-113.01	40.71	3.74	1.79	149	2	87.4	
VEN11VEN	-103.80	12	-66.79	6.90	2.50	1.77	122	2	87.4	

1	2	3	4		5		6	7	8	9
ALS00002	-166.20	13	-109.94	36.86	6.04	1.11	137	1	87.4	9/GR1
ALS00003	-175.20	13	-116.23	37.50	5.60	0.75	132	1	87.4	9/GR2
ARGINSU4	-94.20	13	-52.98	-59.81	3.40	0.68	19	1	87.4	9/GR3
ARGSUR04	-94.20	13	-65.04	-43.33	3.32	1.50	40	1	87.4	9/GR3
B CE311	-64.20	13	-40.60	-6.07	3.04	2.06	174	1	87.4	8/9/GR7
B CE312	-45.20	13	-40.27	-6.06	3.44	2.09	174	1	87.4	8/9/GR9
B CE411	-64.20	13	-50.97	-15.27	3.86	1.38	49	1	87.4	8/9/GR7
B CE412	-45.20	13	-50.71	-15.30	3.57	1.56	52	1	87.4	8/9/GR9
B CE511	-64.20	13	-53.10	-2.90	2.44	2.13	104	1	87.4	8/9/GR7
B NO611	-74.20	13	-59.60	-11.62	2.85	1.69	165	2	87.4	8/9/GR8
B NO711	-74.20	13	-60.70	-1.78	3.54	1.78	126	2	87.4	8/9/GR8
B NO811	-74.20	13	-68.76	-4.71	2.37	1.65	73	2	87.4	8/9/GR8
B SU111	-81.20	13	-51.12	-25.63	2.76	1.05	50	1	87.4	8/9/GR6
B SU112	-45.20	13	-50.75	-25.62	2.47	1.48	56	1	87.4	8/9/GR9
B SU211	-81.20	13	-44.51	-16.95	3.22	1.36	60	1	87.4	8/9/GR6
B SU212	-45.20	13	-44.00	-16.87	3.20	1.96	58	1	87.4	8/9/GR9
BAHIFRB1	-87.20	13	-76.06	24.16	1.81	0.70	142	1	87.4	
BERBERMU	-96.20	13	-64.77	32.32	0.60	0.60	90	2	87.4	
BERBERO2	-31.00	13	-64.77	32.32	0.60	0.60	90	1	87.4	2 3
BOLAND01	-115.20	13	-71.37	-4.69	6.49	2.57	87	1	87.4	9/GR5
CAN01101	-138.20	13	-114.60	51.08	7.28	1.10	160	1	87.4	9/GR10
CAN01201	-138.20	13	-114.60	51.08	7.28	1.10	160	1	87.4	9/GR10
CAN01202	-72.70	13	-81.34	50.02	7.96	2.55	5	1	87.4	
CAN01203	-129.20	13	-113.02	51.08	7.47	1.26	162	1	87.4	9/GR12
CAN01303	-129.20	13	-113.02	51.08	7.47	1.26	162	1	87.4	9/GR12
CAN01304	-91.20	13	-86.71	50.48	8.58	2.54	178	1	87.4	9/GR13
CAN01403	-129.20	13	-113.02	51.08	7.47	1.26	162	1	87.4	9/GR12
CAN01404	-91.20	13	-86.71	50.48	8.58	2.54	178	1	87.4	9/GR13
CAN01405	-82.20	13	-84.11	50.20	8.31	2.58	1	1	87.4	9/GR14
CAN01504	-91.20	13	-86.71	50.48	8.58	2.54	178	1	87.4	9/GR13
CAN01505	-82.20	13	-84.11	50.20	8.31	2.58	1	1	87.4	9/GR14
CAN01605	-82.20	13	-84.11	50.20	8.31	2.58	1	1	87.4	9/GR14
CAN01606	-70.70	13	-80.77	50.03	7.88	2.53	6	1	87.4	
CHLCONT5	-106.20	13	-72.23	-35.57	2.60	0.68	55	1	87.4	9/GR17
CHLPAC02	-106.20	13	-80.06	-30.06	1.36	0.68	69	1	87.4	9/GR17
CLMAND01	-115.20	13	-71.37	-4.69	6.49	2.57	87	1	87.4	9/GR5
CLM00001	-103.20	13	-74.50	5.87	3.98	1.96	118	1	87.4	
EQACAND1	-115.20	13	-71.37	-4.69	6.49	2.57	87	1	87.4	9/GR5
EQAGAND1	-115.20	13	-71.37	-4.69	6.49	2.57	87	1	87.4	9/GR5
FLKANT01	-57.20	13	-44.54	-60.13	3.54	0.68	12	1	87.4	2
FLKFALKS	-31.00	13	-59.90	-51.64	0.60	0.60	90	1	87.4	2 3
GRD00002	-42.20	13	-61.58	12.29	0.60	0.60	90	1	87.4	
HWA00002	-166.20	13	-109.94	36.86	6.04	1.11	137	1	87.4	9/GR1
HWA00003	-175.20	13	-116.23	37.50	5.60	0.75	132	1	87.4	9/GR2
MEX01NTE	-78.20	13	-105.81	26.01	2.89	2.08	155	1	87.4	1
MEX01SUR	-69.20	13	-94.84	19.82	3.05	2.09	4	1	87.4	1
MEX02NTE	-136.20	13	-107.21	26.31	3.84	1.55	148	1	87.4	1
MEX02SUR	-127.20	13	-96.39	19.88	3.18	1.87	157	1	87.4	1
PAQPAC01	-106.20	13	-109.18	-27.53	0.60	0.60	90	1	87.4	9/GR17
PRG00002	-99.20	13	-58.66	-23.32	1.45	1.04	76	1	87.4	
PRUAND02	-115.20	13	-71.37	-4.69	6.49	2.57	87	1	87.4	9/GR5
PTRVIR01	-101.20	13	-93.94	36.32	8.24	3.56	171	1	87.4	1 6 9/GR20
PTRVIR02	-110.20	13	-95.23	36.29	8.27	3.37	168	1	87.4	1 6 9/GR21
SPMFRAN3	-53.20	13	-67.24	47.51	3.16	0.79	7	1	87.4	2 7
TRD00001	-84.70	13	-61.23	10.70	0.60	0.60	90	1	87.4	
URG00001	-71.70	13	-56.22	-32.52	1.02	0.89	11	1	87.4	
USAEH001	-61.70	13	-87.57	36.17	6.42	3.49	12	1	87.4	1 5 6
USAEH002	-101.20	13	-93.94	36.32	8.24	3.56	171	1	87.4	1 6 9/GR20
USAEH003	-110.20	13	-95.23	36.29	8.27	3.37	168	1	87.4	1 6 9/GR21
USAEH004	-119.20	13	-96.45	36.21	8.20	3.12	165	1	87.4	1 5 6
USAPSA02	-166.20	13	-109.94	36.86	6.04	1.11	137	1	87.4	9/GR1
USAPSA03	-175.20	13	-116.23	37.50	5.60	0.75	132	1	87.4	9/GR2
USAWH101	-148.20	13	-111.02	40.68	4.36	2.15	162	1	87.4	
USAWH102	-157.20	13	-113.07	40.74	3.72	1.78	149	1	87.4	
VENAND03	-115.20	13	-71.37	-4.69	6.49	2.57	87	1	87.4	9/GR5
VRG00001	-79.70	13	-64.37	18.48	0.60	0.60	90	1	87.4	4

17 513.54 MHz (14)

1	2	3	4		5		6	7	8	9
ALS00002	-165.80	14	-109.83	36.82	6.03	1.12	137	2	87.4	9/GR1
ALS00003	-174.80	14	-116.10	37.47	5.60	0.76	132	2	87.4	9/GR2
ARGNORT4	-93.80	14	-63.96	-30.01	3.86	1.99	48	2	87.4	
ARGNORT5	-54.80	14	-62.85	-29.80	3.24	2.89	47	2	87.4	
ATNBEM1	-52.80	14	-66.44	14.87	1.83	0.68	39	2	87.4	
B CE311	-63.80	14	-40.60	-6.07	3.04	2.06	174	2	87.4	8 9/GR7
B CE312	-44.80	14	-40.26	-6.06	3.44	2.09	174	2	87.4	8 9/GR9
B CE411	-63.80	14	-50.97	-15.26	3.86	1.38	49	2	87.4	8 9/GR7
B CE412	-44.80	14	-50.71	-15.30	3.57	1.56	52	2	87.4	8 9/GR9
B CE511	-63.80	14	-53.11	-2.98	2.42	2.15	107	2	87.4	8 9/GR7
B NO611	-73.80	14	-59.60	-11.62	2.86	1.69	165	1	87.4	8 9/GR8
B NO711	-73.80	14	-60.70	-1.78	3.54	1.78	126	1	87.4	8 9/GR8
B NO811	-73.80	14	-68.75	-4.71	2.37	1.65	73	1	87.4	8 9/GR8
B SE911	-101.80	14	-45.99	-19.09	2.22	0.79	62	2	87.4	8
B SU111	-80.80	14	-51.10	-25.64	2.76	1.06	50	2	87.4	8 9/GR6
B SU112	-44.80	14	-50.76	-25.62	2.47	1.48	56	2	87.4	8 9/GR9
B SU211	-80.80	14	-44.51	-16.94	3.22	1.37	60	2	87.4	8 9/GR6
B SU212	-44.80	14	-43.99	-16.97	3.27	1.92	59	2	87.4	8 9/GR9
CAN01101	-137.80	14	-114.10	50.92	7.22	1.11	160	2	87.4	9/GR10
CAN01201	-137.80	14	-114.10	50.92	7.22	1.11	160	2	87.4	9/GR10
CAN01202	-72.30	14	-81.23	50.12	7.99	2.53	5	2	87.4	
CAN01203	-128.80	14	-113.04	51.04	7.53	1.26	162	2	87.4	9/GR12
CAN01303	-128.80	14	-113.04	51.04	7.53	1.26	162	2	87.4	9/GR12
CAN01304	-90.80	14	-86.57	50.48	8.59	2.54	178	2	87.4	9/GR13
CAN01403	-128.80	14	-113.04	51.04	7.53	1.26	162	2	87.4	9/GR12
CAN01404	-90.80	14	-86.57	50.48	8.59	2.54	178	2	87.4	9/GR13
CAN01405	-81.80	14	-83.80	50.22	8.35	2.57	2	2	87.4	9/GR14
CAN01504	-90.80	14	-86.57	50.48	8.59	2.54	178	2	87.4	9/GR13
CAN01505	-81.80	14	-83.80	50.22	8.35	2.57	2	2	87.4	9/GR14
CAN01605	-81.80	14	-83.80	50.22	8.35	2.57	2	2	87.4	9/GR14
CAN01606	-70.30	14	-80.64	50.02	7.88	2.52	6	2	87.4	
CHLCON4	-105.80	14	-69.59	-23.20	2.21	0.69	68	2	87.4	9/GR16
CHLCON7	-105.80	14	-73.52	-55.52	3.65	1.31	39	2	87.4	9/GR16
CRBBAH01	-92.30	14	-76.09	24.13	1.83	0.68	141	1	87.4	9/GR18
CRBBER01	-92.30	14	-64.76	32.13	0.60	0.60	90	1	87.4	9/GR18
CRBBLZ01	-92.30	14	-88.61	17.26	0.64	0.64	90	1	87.4	9/GR18
CRBEC001	-92.30	14	-60.07	8.26	4.20	0.86	115	1	87.4	9/GR18
CRBJMC01	-92.30	14	-79.45	17.97	0.99	0.68	151	1	87.4	9/GR18
CTRO0201	-130.80	14	-84.33	9.67	0.82	0.68	119	2	87.4	
EQAC0001	-94.80	14	-78.31	-1.52	1.48	1.15	65	1	87.4	9/GR19
EQAG0001	-94.80	14	-90.36	-0.57	0.94	0.89	99	1	87.4	9/GR19
GUY00302	-33.80	14	-59.07	4.77	1.43	0.85	91	2	87.4	
HNDIFR2	-107.30	14	-86.23	15.16	1.14	0.85	8	1	87.4	
HTI00002	-83.30	14	-73.28	18.96	0.82	0.68	11	2	87.4	
HWA00002	-165.80	14	-109.83	36.82	6.03	1.12	137	2	87.4	9/GR1
HWA00003	-174.80	14	-116.10	37.47	5.60	0.76	132	2	87.4	9/GR2
MEX01NTE	-77.80	14	-105.80	25.99	2.88	2.07	155	2	87.4	1
MEX02NTE	-135.80	14	-107.36	26.32	3.80	1.57	149	2	87.4	1
MEX02SUR	-126.80	14	-96.39	19.88	3.19	1.87	158	2	87.4	1
PRU00004	-85.80	14	-74.19	-8.39	3.74	2.45	112	2	87.4	
PTRVIR01	-100.80	14	-93.85	36.31	8.26	3.55	171	2	87.4	1 6 9/GR20
PTRVIR02	-109.80	14	-95.47	36.38	8.10	3.45	168	2	87.4	1 6 9/GR21
TCA00001	-115.80	14	-71.79	21.53	0.60	0.60	90	2	87.4	
USAEH001	-61.30	14	-87.53	36.18	6.41	3.49	12	2	87.4	1 5 6
USAEH002	-100.80	14	-93.85	36.31	8.26	3.55	171	2	87.4	1 6 9/GR20
USAEH003	-109.80	14	-95.47	36.38	8.10	3.45	168	2	87.4	1 6 9/GR21
USAEH004	-118.80	14	-96.42	36.21	8.20	3.12	165	2	87.4	1 5 6
USAPSA02	-165.80	14	-109.83	36.82	6.03	1.12	137	2	87.4	9/GR1
USAPSA03	-174.80	14	-116.10	37.47	5.60	0.76	132	2	87.4	9/GR2
USAWH101	-147.80	14	-111.01	40.67	4.38	2.15	162	2	87.4	
USAWH102	-156.80	14	-113.01	40.71	3.74	1.79	149	2	87.4	
VCT00001	-79.30	14	-61.18	13.23	0.60	0.60	90	2	87.4	
VEN11VEN	-103.80	14	-66.79	6.90	2.50	1.77	122	2	87.4	

1	2	3	4	5	6	7	8	9		
ALS00002	-166.20	15	-109.94	36.86	6.04	1.11	137	1	87.4	9/GR1
ALS00003	-175.20	15	-116.23	37.50	5.60	0.75	132	1	87.4	9/GR2
ARGINSU4	-94.20	15	-52.98	-59.81	3.40	0.68	19	1	87.4	9/GR3
ARGINSU5	-55.20	15	-44.17	-59.91	3.77	0.70	13	1	87.4	9/GR4
ARGSUR04	-94.20	15	-65.04	-43.33	3.32	1.50	40	1	87.4	9/GR3
ARGSUR05	-55.20	15	-63.68	-43.01	2.54	2.38	152	1	87.4	9/GR4
ATGSJN01	-79.70	15	-61.79	17.07	0.60	0.60	90	1	87.4	
B CE311	-64.20	15	-40.60	-6.07	3.04	2.06	174	1	87.4	8 9/GR7
B CE312	-45.20	15	-40.27	-6.06	3.44	2.09	174	1	87.4	8 9/GR9
B CE411	-64.20	15	-50.97	-15.27	3.86	1.38	49	1	87.4	8 9/GR7
B CE412	-45.20	15	-50.71	-15.30	3.57	1.56	52	1	87.4	8 9/GR9
B CE511	-64.20	15	-53.10	-2.90	2.44	2.13	104	1	87.4	8 9/GR7
B NO611	-74.20	15	-59.60	-11.62	2.85	1.69	165	2	87.4	8 9/GR8
B NO711	-74.20	15	-60.70	-1.78	3.54	1.78	126	2	87.4	8 9/GR8
B NO811	-74.20	15	-68.76	-4.71	2.37	1.65	73	2	87.4	8 9/GR8
B SU111	-81.20	15	-51.12	-25.63	2.76	1.05	50	1	87.4	8 9/GR6
B SU112	-45.20	15	-50.75	-25.62	2.47	1.48	56	1	87.4	8 9/GR9
B SU211	-81.20	15	-44.51	-16.95	3.22	1.36	60	1	87.4	8 9/GR6
B SU212	-45.20	15	-44.00	-16.87	3.20	1.96	58	1	87.4	8 9/GR9
BERBERMU	-96.20	15	-64.77	32.32	0.60	0.60	90	2	87.4	
BOLAND01	-115.20	15	-71.37	-4.69	6.49	2.57	87	1	87.4	9/GR5
BOL00001	-87.20	15	-64.61	-16.71	2.52	2.19	85	1	87.4	
BRB00001	-92.70	15	-59.85	12.93	0.60	0.60	90	2	87.4	
CAN01101	-138.20	15	-114.60	51.08	7.28	1.10	160	1	87.4	9/GR10
CAN01201	-138.20	15	-114.60	51.08	7.28	1.10	160	1	87.4	9/GR10
CAN01202	-72.70	15	-81.34	50.02	7.96	2.55	5	1	87.4	
CAN01203	-129.20	15	-113.02	51.08	7.47	1.26	162	1	87.4	9/GR12
CAN01303	-129.20	15	-113.02	51.08	7.47	1.26	162	1	87.4	9/GR12
CAN01304	-91.20	15	-86.71	50.48	8.58	2.54	178	1	87.4	9/GR13
CAN01403	-129.20	15	-113.02	51.08	7.47	1.26	162	1	87.4	9/GR12
CAN01404	-91.20	15	-86.71	50.48	8.58	2.54	178	1	87.4	9/GR13
CAN01405	-82.20	15	-84.11	50.20	8.31	2.58	1	1	87.4	9/GR14
CAN01504	-91.20	15	-86.71	50.48	8.58	2.54	178	1	87.4	9/GR13
CAN01505	-82.20	15	-84.11	50.20	8.31	2.58	1	1	87.4	9/GR14
CAN01605	-82.20	15	-84.11	50.20	8.31	2.58	1	1	87.4	9/GR14
CAN01606	-70.70	15	-80.77	50.03	7.88	2.53	6	1	87.4	
CHLCONT5	-106.20	15	-72.23	-35.57	2.60	0.68	55	1	87.4	9/GR17
CHLPAC02	-106.20	15	-80.06	-30.06	1.36	0.68	69	1	87.4	9/GR17
CLMAND01	-115.20	15	-71.37	-4.69	6.49	2.57	87	1	87.4	9/GR5
CLM00001	-103.20	15	-74.50	5.87	3.98	1.96	118	1	87.4	
CUB00001	-89.20	15	-79.81	21.62	2.24	0.68	168	1	87.4	
EQACAND1	-115.20	15	-71.37	-4.69	6.49	2.57	87	1	87.4	9/GR5
EQAGAND1	-115.20	15	-71.37	-4.69	6.49	2.57	87	1	87.4	9/GR5
GRD00002	-42.20	15	-61.58	12.29	0.60	0.60	90	1	87.4	
GRD00059	-57.20	15	-61.58	12.29	0.60	0.60	90	1	87.4	
GRLDNK01	-53.20	15	-44.89	66.56	2.70	0.82	173	1	87.4	2
GUY0201	-84.70	15	-59.19	4.78	1.44	0.85	95	1	87.4	
HWA00002	-166.20	15	-109.94	36.86	6.04	1.11	137	1	87.4	9/GR1
HWA00003	-175.20	15	-116.23	37.50	5.60	0.75	132	1	87.4	9/GR2
MEX01NTE	-78.20	15	-105.81	26.01	2.89	2.08	155	1	87.4	1
MEX01SUR	-69.20	15	-94.84	19.82	3.05	2.09	4	1	87.4	1
MEX02NTE	-136.20	15	-107.21	26.31	3.84	1.55	148	1	87.4	1
MEX02SUR	-127.20	15	-96.39	19.88	3.18	1.87	157	1	87.4	1
PAQAC01	-106.20	15	-109.18	-27.53	0.60	0.60	90	1	87.4	9/GR17
PRG00002	-99.20	15	-58.66	-23.32	1.45	1.04	76	1	87.4	
PRUAND02	-115.20	15	-71.37	-4.69	6.49	2.57	87	1	87.4	9/GR5
PTRVIR01	-101.20	15	-93.94	36.32	8.24	3.56	171	1	87.4	1 6 9/GR20
PTRVIR02	-110.20	15	-95.23	36.29	8.27	3.37	168	1	87.4	1 6 9/GR21
URG00001	-71.70	15	-56.22	-32.52	1.02	0.89	11	1	87.4	
USAEH001	-61.70	15	-87.57	36.17	6.42	3.49	12	1	87.4	1 5 6
USAEH002	-101.20	15	-93.94	36.32	8.24	3.56	171	1	87.4	1 6 9/GR20
USAEH003	-110.20	15	-95.23	36.29	8.27	3.37	168	1	87.4	1 6 9/GR21
USAEH004	-119.20	15	-96.45	36.21	8.20	3.12	165	1	87.4	1 5 6
USAPSA02	-166.20	15	-109.94	36.86	6.04	1.11	137	1	87.4	9/GR1
USAPSA03	-175.20	15	-116.23	37.50	5.60	0.75	132	1	87.4	9/GR2
USAWH101	-148.20	15	-111.02	40.68	4.36	2.15	162	1	87.4	
USAWH102	-157.20	15	-113.07	40.74	3.72	1.78	149	1	87.4	
VENAND03	-115.20	15	-71.37	-4.69	6.49	2.57	87	1	87.4	9/GR5

17 542.70 MHz (16)

1	2	3	4	5	6	7	8	9		
ALS00002	-165.80	16	-109.83	36.82	6.03	1.12	137	2	87.4	9/GR1
ALS00003	-174.80	16	-116.10	37.47	5.60	0.76	132	2	87.4	9/GR2
ARGNORT4	-93.80	16	-63.96	-30.01	3.86	1.99	48	2	87.4	
ARGNORT5	-54.80	16	-62.85	-29.80	3.24	2.89	47	2	87.4	
B CE311	-63.80	16	-40.60	-6.07	3.04	2.06	174	2	87.4	8 9/GR7
B CE312	-44.80	16	-40.26	-6.06	3.44	2.09	174	2	87.4	
B CE411	-63.80	16	-50.97	-15.26	3.86	1.38	49	2	87.4	8 9/GR7
B CE412	-44.80	16	-50.71	-15.30	3.57	1.56	52	2	87.4	8 9/GR9
B CE511	-63.80	16	-53.11	-2.98	2.42	2.15	107	2	87.4	8 9/GR7
B NO611	-73.80	16	-59.60	-11.62	2.86	1.69	165	1	87.4	8 9/GR8
B NO711	-73.80	16	-60.70	-1.78	3.54	1.78	126	1	87.4	8 9/GR8
B NOR11	-73.80	16	-68.75	-4.71	2.37	1.65	73	1	87.4	8 9/GR8
B SE911	-101.80	16	-45.99	-19.09	2.22	0.79	62	2	87.4	8
B SU111	-80.80	16	-51.10	-25.64	2.76	1.06	50	2	87.4	8 9/GR6
B SU112	-44.80	16	-50.76	-25.62	2.47	1.48	56	2	87.4	8 9/GR9
B SU211	-80.80	16	-44.51	-16.94	3.22	1.37	60	2	87.4	8 9/GR6
B SU212	-44.80	16	-43.99	-16.97	3.27	1.92	59	2	87.4	8 9/GR9
CAN01101	-137.80	16	-114.10	50.92	7.22	1.11	160	2	87.4	9/GR10
CAN01201	-137.80	16	-114.10	50.92	7.22	1.11	160	2	87.4	9/GR10
CAN01202	-72.30	16	-81.23	50.12	7.99	2.53	5	2	87.4	
CAN01203	-128.80	16	-113.04	51.04	7.53	1.26	162	2	87.4	9/GR12
CAN01303	-128.80	16	-113.04	51.04	7.53	1.26	162	2	87.4	9/GR12
CAN01304	-90.80	16	-86.57	50.48	8.59	2.54	178	2	87.4	9/GR13
CAN01403	-128.80	16	-113.04	51.04	7.53	1.26	162	2	87.4	9/GR12
CAN01404	-90.80	16	-86.57	50.48	8.59	2.54	178	2	87.4	9/GR13
CAN01405	-81.80	16	-83.80	50.22	8.35	2.57	2	2	87.4	9/GR14
CAN01504	-90.80	16	-86.57	50.48	8.59	2.54	178	2	87.4	9/GR13
CAN01505	-81.80	16	-83.80	50.22	8.35	2.57	2	2	87.4	9/GR14
CAN01605	-81.80	16	-83.80	50.22	8.35	2.57	2	2	87.4	9/GR14
CAN01606	-70.30	16	-80.64	50.02	7.88	2.52	6	2	87.4	
CHLCONT4	-105.80	16	-69.59	-23.20	2.21	0.69	68	2	87.4	9/GR16
CHLCONT6	-105.80	16	-73.52	-55.52	3.65	1.31	39	2	87.4	9/GR16
CRBBAH01	-92.30	16	-76.09	24.13	1.83	0.68	141	1	87.4	9/GR18
CRBBER01	-92.30	16	-64.76	32.13	0.60	0.60	90	1	87.4	9/GR18
CRBBLZ01	-92.30	16	-88.61	17.26	0.64	0.64	90	1	87.4	9/GR18
CRBEC001	-92.30	16	-60.07	8.26	4.20	0.86	115	1	87.4	9/GR18
CRBJMC01	-92.30	16	-79.45	17.97	0.99	0.68	151	1	87.4	9/GR18
CYM00001	-115.80	16	-80.58	19.57	0.60	0.60	90	2	87.4	
DOMIFRB2	-83.30	16	-70.51	18.79	0.98	0.69	167	2	87.4	
EQAC0001	-94.80	16	-78.31	-1.52	1.48	1.15	65	1	87.4	9/GR19
EQAG0001	-94.80	16	-90.36	-0.57	0.94	0.89	99	1	87.4	9/GR19
GUFMGG02	-52.80	16	-56.42	8.47	4.16	0.81	123	2	87.4	2 7
HWA00002	-165.80	16	-109.83	36.82	6.03	1.12	137	2	87.4	9/GR1
HWA00003	-174.80	16	-116.10	37.47	5.60	0.76	132	2	87.4	9/GR2
JMC00005	-33.80	16	-77.27	18.12	0.60	0.60	90	2	87.4	
LCAIFRB1	-79.30	16	-61.15	13.90	0.60	0.60	90	2	87.4	
MEX01NTE	-77.80	16	-105.80	25.99	2.88	2.07	155	2	87.4	1
MEX02NTE	-135.80	16	-107.36	26.32	3.80	1.57	149	2	87.4	1
MEX02SUR	-126.80	16	-96.39	19.88	3.19	1.87	158	2	87.4	1
PRU00004	-85.80	16	-74.19	-8.39	3.74	2.45	112	2	87.4	
PTRVIR01	-100.80	16	-93.85	36.31	8.26	3.55	171	2	87.4	1 6 9/GR20
PTRVIR02	-109.80	16	-109.80	36.38	8.10	3.45	168	2	87.4	1 6 9/GR21
SLVIFRB2	-107.30	16	-88.91	13.59	0.60	0.60	90	1	87.4	
USAEH001	-61.30	16	-87.53	36.18	6.41	3.49	12	2	87.4	1 5 6
USAEH002	-100.80	16	-93.85	36.31	8.26	3.55	171	2	87.4	1 6 9/GR20
USAEH003	-109.80	16	-95.47	36.38	8.10	3.45	168	2	87.4	1 6 9/GR21
USAEH004	-118.80	16	-96.42	36.21	8.20	3.12	165	2	87.4	1 5 6
USAPSA02	-165.80	16	-109.83	36.82	6.03	1.12	137	2	87.4	9/GR1
USAPSA03	-174.80	16	-116.10	37.47	5.60	0.76	132	2	87.4	9/GR2
USAWH101	-147.80	16	-111.01	40.67	4.38	2.15	162	2	87.4	
USAWH102	-156.80	16	-113.01	40.71	3.74	1.79	149	2	87.4	
VEN11VEN	-103.80	16	-66.79	6.90	2.50	1.77	122	2	87.4	



1	2	3	4	5	6	7	8	9		
ALS00002	-166.20	17	-109.94	36.86	6.04	1.11	137	1	87.4	9/GR1
ALS00003	-175.20	17	-116.23	37.50	5.60	0.75	132	1	87.4	9/GR2
ARGINSU4	-94.20	17	-52.98	-59.81	3.40	0.68	19	1	87.4	9/GR3
ARGINSU5	-55.20	17	-44.17	-59.91	3.77	0.70	13	1	87.4	9/GR4
ARGSUR04	-94.20	17	-65.04	-43.33	3.32	1.50	40	1	87.4	9/GR3
ARGSUR05	-55.20	17	-63.68	-43.01	2.54	2.38	152	1	87.4	9/GR4
B CE311	-64.20	17	-40.60	-6.07	3.04	2.06	174	1	87.4	9/GR3
B CE312	-45.20	17	-40.27	-6.06	3.44	2.09	174	1	87.4	9/GR4
B CE411	-64.20	17	-50.97	-15.27	3.86	1.38	49	1	87.4	8 9/GR7
B CE412	-45.20	17	-50.71	-15.30	3.57	1.56	52	1	87.4	8 9/GR9
B CE511	-64.20	17	-53.10	-2.90	2.44	2.13	104	1	87.4	8 9/GR7
B NO611	-74.20	17	-59.60	-11.62	2.85	1.69	165	2	87.4	8 9/GR8
B NO711	-74.20	17	-60.70	-1.78	3.54	1.78	126	2	87.4	8 9/GR8
B NO811	-74.20	17	-68.76	-4.71	2.37	1.65	73	2	87.4	8 9/GR8
B SU111	-81.20	17	-51.12	-25.63	2.76	1.05	50	1	87.4	8 9/GR6
B SU112	-45.20	17	-50.75	-25.62	2.47	1.48	56	1	87.4	8 9/GR9
B SU211	-81.20	17	-44.51	-16.95	3.22	1.36	60	1	87.4	8 9/GR6
B SU212	-45.20	17	-44.00	-16.87	3.20	1.96	58	1	87.4	8 9/GR9
BERBERMU	-96.20	17	-64.77	32.32	0.60	0.60	90	2	87.4	
BERBER02	-31.00	17	-64.77	32.32	0.60	0.60	90	1	87.4	2 3
BOLAND01	-115.20	17	-71.37	-4.69	6.49	2.57	87	1	87.4	9/GR5
CAN01101	-138.20	17	-125.63	57.24	3.45	1.27	157	1	87.4	9/GR10
CAN01201	-138.20	17	-112.04	55.95	3.35	0.97	151	1	87.4	9/GR10
CAN01202	-72.70	17	-107.70	55.63	2.74	1.12	32	1	87.4	
CAN01203	-129.20	17	-111.48	55.61	3.08	1.15	151	1	87.4	9/GR12
CAN01303	-129.20	17	-102.42	57.12	3.54	0.91	154	1	87.4	9/GR12
CAN01304	-91.20	17	-99.12	57.36	1.98	1.72	2	1	87.4	9/GR13
CAN01403	-129.20	17	-89.75	52.02	4.68	0.78	148	1	87.4	9/GR12
CAN01404	-91.20	17	-84.82	52.42	3.10	2.05	152	1	87.4	9/GR13
CAN01405	-82.20	17	-84.00	52.39	2.84	2.29	172	1	87.4	9/GR14
CAN01504	-91.20	17	-72.66	53.77	3.57	1.67	156	1	87.4	9/GR13
CAN01505	-82.20	17	-71.77	53.79	3.30	1.89	162	1	87.4	9/GR14
CAN01605	-82.20	17	-61.50	49.55	2.65	1.40	143	1	87.4	9/GR14
CAN01606	-70.70	17	-61.30	49.55	2.40	1.65	148	1	87.4	
CHLCONT5	-106.20	17	-72.23	-35.57	2.60	0.68	55	1	87.4	9/GR17
CHLPA02	-106.20	17	-80.06	-30.06	1.36	0.68	69	1	87.4	9/GR17
CLMAND01	-115.20	17	-71.37	-4.69	6.49	2.57	87	1	87.4	9/GR5
CLM00001	-103.20	17	-74.50	5.87	3.98	1.96	118	1	87.4	
EQACAND1	-115.20	17	-71.37	-4.69	6.49	2.57	87	1	87.4	9/GR5
EQAGAND1	-115.20	17	-71.37	-4.69	6.49	2.57	87	1	87.4	9/GR5
FLKFALKS	-31.00	17	-59.90	-51.64	0.60	0.60	90	1	87.4	2 3
HWA00002	-166.20	17	-165.79	23.42	4.20	0.68	160	1	87.4	9/GR1
HWA00003	-175.20	17	-166.10	23.42	4.25	0.68	159	1	87.4	9/GR2
JMC00002	-92.70	17	-77.30	18.12	0.62	0.62	90	2	87.4	
KNA00001	-79.70	17	-62.46	17.44	0.60	0.60	90	1	87.4	
MEX01NTE	-78.20	17	-105.81	26.01	2.89	2.08	155	1	87.4	1
MEX01SUR	-69.20	17	-94.84	19.82	3.05	2.09	4	1	87.4	1
MEX02NTE	-136.20	17	-107.21	26.31	3.84	1.55	148	1	87.4	1
MEX02SUR	-127.20	17	-96.39	19.88	3.18	1.87	157	1	87.4	1
PAQPAC01	-106.20	17	-109.18	-27.53	0.60	0.60	90	1	87.4	9/GR17
PRG00002	-99.20	17	-58.66	-23.32	1.45	1.04	76	1	87.4	
PRUAND02	-115.20	17	-71.37	-4.69	6.49	2.57	87	1	87.4	9/GR5
PTRVIR01	-101.20	17	-93.94	36.32	8.24	3.56	171	1	87.4	1 6 9/GR20
PTRVIR02	-110.20	17	-95.23	36.29	8.27	3.37	168	1	87.4	1 6 9/GR21
SPMFRAN3	-53.20	17	-67.24	47.51	3.16	0.79	7	1	87.4	2 7
SURINAM2	-84.70	17	-55.69	4.35	1.00	0.69	86	1	87.4	
URG00001	-71.70	17	-56.22	-32.52	1.02	0.89	11	1	87.4	
USAEH001	-61.70	17	-87.57	36.17	6.42	3.49	12	1	87.4	1 5 6
USAEH002	-101.20	17	-93.94	36.32	8.24	3.56	171	1	87.4	1 6 9/GR20
USAEH003	-110.20	17	-95.23	36.29	8.27	3.37	168	1	87.4	1 6 9/GR21
USAEH004	-119.20	17	-96.45	36.21	8.20	3.12	165	1	87.4	1 5 6
USAPSA02	-166.20	17	-109.94	36.86	6.04	1.11	137	1	87.4	9/GR1
USAPSA03	-175.20	17	-116.23	37.50	5.60	0.75	132	1	87.4	9/GR2
USAWH101	-148.20	17	-111.02	40.68	4.36	2.15	162	1	87.4	
USAWH102	-157.20	17	-113.07	40.74	3.72	1.78	149	1	87.4	
VENAND03	-115.20	17	-71.37	-4.69	6.49	2.57	87	1	87.4	9/GR5

17 571.86 MHz (18)

1	2	3	4	5	6	7	8	9		
ALS00002	-165.80	18	-109.83	36.82	6.03	1.12	137	2	87.4	9/GR1
ALS00003	-174.80	18	-116.10	37.47	5.60	0.76	132	2	87.4	9/GR2
ARGNORT4	-93.80	18	-63.96	-30.01	3.86	1.99	48	2	87.4	
ARGNORT5	-54.80	18	-62.85	-29.80	3.24	2.89	47	2	87.4	
ATNBEM1	-52.80	18	-66.44	14.87	1.83	0.68	39	2	87.4	
B CE311	-63.80	18	-40.60	-6.07	3.04	2.06	174	2	87.4	8 9/GR7
B CE312	-44.80	18	-40.26	-6.06	3.44	2.09	174	2	87.4	8 9/GR9
B CE411	-63.80	18	-50.97	-15.26	3.86	1.38	49	2	87.4	8 9/GR7
B CE412	-44.80	18	-50.71	-15.30	3.57	1.56	52	2	87.4	8 9/GR9
B CE511	-63.80	18	-53.11	-2.98	2.42	2.15	107	2	87.4	8 9/GR7
B NO611	-73.80	18	-59.60	-11.62	2.86	1.69	165	1	87.4	8 9/GR8
B NO711	-73.80	18	-60.70	-1.78	3.54	1.78	126	1	87.4	8 9/GR8
B NO811	-73.80	18	-68.75	-4.71	2.37	1.65	73	1	87.4	8 9/GR8
B SE911	-101.80	18	-45.99	-19.09	2.22	0.79	62	2	87.4	8
B SU111	-80.80	18	-51.10	-25.64	2.76	1.06	50	2	87.4	8 9/GR6
B SU112	-44.80	18	-50.76	-25.62	2.47	1.48	56	2	87.4	8 9/GR9
B SU211	-80.80	18	-44.51	-16.94	3.22	1.37	60	2	87.4	8 9/GR6
B SU212	-44.80	18	-43.99	-16.97	3.27	1.92	59	2	87.4	8 9/GR9
BLZ00001	-115.80	18	-88.68	17.27	0.62	0.62	90	2	87.4	
CAN01101	-137.80	18	-125.60	57.24	3.45	1.27	157	2	87.4	9/GR10
CAN01201	-137.80	18	-111.92	55.89	3.33	0.98	151	2	87.4	9/GR10
CAN01202	-72.30	18	-107.64	55.62	2.75	1.11	32	2	87.4	
CAN01203	-128.80	18	-111.43	55.56	3.07	1.15	151	2	87.4	9/GR12
CAN01303	-128.80	18	-102.39	57.12	3.54	0.92	154	2	87.4	9/GR12
CAN01304	-90.80	18	-99.00	57.33	1.96	1.73	1	2	87.4	9/GR13
CAN01403	-128.80	18	-89.70	52.02	4.67	0.79	148	2	87.4	9/GR12
CAN01404	-90.80	18	-84.78	52.41	3.09	2.06	153	2	87.4	9/GR13
CAN01405	-81.80	18	-84.02	52.34	2.82	2.30	172	2	87.4	9/GR14
CAN01504	-90.80	18	-72.68	53.78	3.57	1.67	157	2	87.4	9/GR13
CAN01505	-81.80	18	-71.76	53.76	3.30	1.89	162	2	87.4	9/GR14
CAN01605	-81.80	18	-61.54	49.50	2.66	1.39	144	2	87.4	9/GR14
CAN01606	-70.30	18	-61.32	49.51	2.41	1.65	148	2	87.4	
CHLCONT4	-105.80	18	-69.59	-23.20	2.21	0.69	68	2	87.4	9/GR16
CHLCONT6	-105.80	18	-73.52	-55.52	3.65	1.31	39	2	87.4	9/GR16
CRBBAH01	-92.30	18	-76.09	24.13	1.83	0.68	141	1	87.4	9/GR18
CRBBER01	-92.30	18	-64.76	32.13	0.60	0.60	90	1	87.4	9/GR18
CRBBLZ01	-92.30	18	-88.61	17.26	0.64	0.64	90	1	87.4	9/GR18
CRBEC001	-92.30	18	-60.07	8.26	4.20	0.86	115	1	87.4	9/GR18
CRBJMC01	-92.30	18	-79.45	17.97	0.99	0.68	151	1	87.4	9/GR18
CTR00201	-130.80	18	-84.33	9.67	0.82	0.68	119	2	87.4	
DMAIFRB1	-79.30	18	-61.30	15.35	0.60	0.60	90	2	87.4	
EQAC0001	-94.80	18	-78.31	-1.52	1.48	1.15	65	1	87.4	9/GR19
EQAG0001	-94.80	18	-90.36	-0.57	0.94	0.89	99	1	87.4	9/GR19
HWAA0002	-165.80	18	-165.79	23.32	4.20	0.68	160	2	87.4	9/GR1
HWAA0003	-174.80	18	-166.10	23.42	4.25	0.68	159	2	87.4	9/GR2
MEX01NTE	-77.80	18	-105.80	25.99	2.88	2.07	155	2	87.4	1
MEX02NTE	-135.80	18	-107.36	26.32	3.80	1.57	149	2	87.4	1
MEX02SUR	-126.80	18	-96.39	19.88	3.19	1.87	158	2	87.4	1
NCG00003	-107.30	18	-84.99	12.90	1.05	1.01	176	1	87.4	
PRU00004	-85.80	18	-74.19	-8.39	3.74	2.45	112	2	87.4	
PTRVIR01	-100.80	18	-93.85	36.31	8.26	3.55	171	2	87.4	1 6 9/GR20
PTRVIR02	-109.80	18	-95.47	36.38	8.10	3.45	168	2	87.4	1 6 9/GR21
USAEH001	-61.30	18	-87.53	36.18	6.41	3.49	12	2	87.4	1 5 6
USAEH002	-100.80	18	-93.85	36.31	8.26	3.55	171	2	87.4	1 6 9/GR20
USAEH003	-109.80	18	-95.47	36.38	8.10	3.45	168	2	87.4	1 6 9/GR21
USAEH004	-118.80	18	-96.42	36.21	8.20	3.12	165	2	87.4	1 5 6
USAPSA02	-165.80	18	-109.83	36.82	6.03	1.12	137	2	87.4	9/GR1
USAPSA03	-174.80	18	-116.10	37.47	5.60	0.76	132	2	87.4	9/GR2
USAWH01	-147.80	18	-111.01	40.67	4.38	2.15	162	2	87.4	
USAWH02	-156.80	18	-113.01	40.71	3.74	1.79	149	2	87.4	
VEN11VEN	-103.80	18	-66.79	6.90	2.50	1.77	122	2	87.4	

1	2	3	4		5		6	7	8	9
ALS00002	-166.20	19	-109.94	36.86	6.04	1.11	137	1	87.4	9/GR1
ALS00003	-175.20	19	-116.23	37.50	5.60	0.75	132	1	87.4	9/GR2
ARGINSU4	-94.20	19	-52.98	-59.81	3.40	0.68	19	1	87.4	9/GR3
ARGINSU5	-55.20	19	-44.17	-59.91	3.77	0.70	13	1	87.4	9/GR4
ARGSUR04	-94.20	19	-65.04	-43.33	3.32	1.50	40	1	87.4	9/GR3
ARGSUR05	-55.20	19	-63.68	-43.01	2.54	2.38	152	1	87.4	9/GR4
B CE311	-64.20	19	-40.60	-6.07	3.04	2.06	174	1	87.4	8 9/GR7
B CE312	-45.20	19	-40.27	-6.06	3.44	2.09	174	1	87.4	8 9/GR9
B CE411	-64.20	19	-50.97	-15.27	3.86	1.38	49	1	87.4	8 9/GR7
B CE412	-45.20	19	-50.71	-15.30	3.57	1.56	52	1	87.4	8 9/GR9
B CE511	-64.20	19	-53.10	-2.90	2.44	2.13	104	1	87.4	8 9/GR7
B NO611	-74.20	19	-59.60	-11.62	2.85	1.69	165	2	87.4	8 9/GR8
B NO711	-74.20	19	-60.70	-1.78	3.54	1.78	126	2	87.4	8 9/GR8
B NO811	-74.20	19	-68.76	-4.71	2.37	1.65	73	2	87.4	8 9/GR8
B SU111	-81.20	19	-51.12	-25.63	2.76	1.05	50	1	87.4	8 9/GR6
B SU112	-45.20	19	-50.75	-25.62	2.47	1.48	56	1	87.4	8 9/GR9
B SU211	-81.20	19	-44.51	-16.95	3.22	1.36	60	1	87.4	8 9/GR6
B SU212	-45.20	19	-44.00	-16.87	3.20	1.96	58	1	87.4	8 9/GR9
BERBERMU	-96.20	19	-64.77	32.32	0.60	0.60	90	2	87.4	
BOLAND01	-115.20	19	-71.37	-4.69	6.49	2.57	87	1	87.4	9/GR5
BOL00001	-87.20	19	-64.61	-16.71	2.52	2.19	85	1	87.4	
BRB00001	-92.70	19	-59.85	12.93	0.60	0.60	90	2	87.4	
CAN01101	-138.20	19	-125.63	57.24	3.45	1.27	157	1	87.4	9/GR10
CAN01201	-138.20	19	-112.04	55.95	3.35	0.97	151	1	87.4	9/GR10
CAN01202	-72.70	19	-107.70	55.63	2.74	1.12	32	1	87.4	
CAN01203	-129.20	19	-111.48	55.61	3.08	1.15	151	1	87.4	9/GR12
CAN01303	-129.20	19	-102.42	57.12	3.54	0.91	154	1	87.4	9/GR12
CAN01304	-91.20	19	-99.12	57.36	1.98	1.72	2	1	87.4	9/GR13
CAN01403	-129.20	19	-89.75	52.02	4.68	0.78	148	1	87.4	9/GR12
CAN01404	-91.20	19	-84.82	52.42	3.10	2.05	152	1	87.4	9/GR13
CAN01405	-82.20	19	-84.00	52.39	2.84	2.29	172	1	87.4	9/GR14
CAN01504	-91.20	19	-72.66	53.77	3.57	1.67	156	1	87.4	9/GR13
CAN01505	-82.20	19	-71.77	53.79	3.30	1.89	162	1	87.4	9/GR14
CAN01605	-82.20	19	-61.50	49.55	2.65	1.40	143	1	87.4	9/GR14
CAN01606	-70.70	19	-61.30	49.55	2.40	1.65	148	1	87.4	
CHLCONT5	-106.20	19	-72.23	-35.57	2.60	0.68	55	1	87.4	9/GR17
CHLPC02	-106.20	19	-80.06	-30.06	1.36	0.68	69	1	87.4	9/GR17
CLMAND01	-115.20	19	-71.37	-4.69	6.49	2.57	87	1	87.4	9/GR5
CLM00001	-103.20	19	-74.50	5.87	3.98	1.96	118	1	87.4	
CUB00001	-89.20	19	-79.81	21.62	2.24	0.68	168	1	87.4	
EQACAND1	-115.20	19	-71.37	-4.69	6.49	2.57	87	1	87.4	9/GR5
EQAGAND1	-115.20	19	-71.37	-4.69	6.49	2.57	87	1	87.4	9/GR5
GRD00059	-57.20	19	-61.58	12.29	0.60	0.60	90	1	87.4	
GRLDNK01	-53.20	19	-44.89	66.56	2.70	0.82	173	1	87.4	2
GUY00201	-84.70	19	-59.19	4.78	1.44	0.85	95	1	87.4	
HWA00002	-166.20	19	-165.79	23.42	4.20	0.68	160	1	87.4	9/GR1
HWA00003	-175.20	19	-166.10	23.42	4.25	0.68	159	1	87.4	9/GR2
MEX01NTE	-78.20	19	-105.81	26.01	2.89	2.08	155	1	87.4	1
MEX01SUR	-69.20	19	-94.84	19.82	3.05	2.09	4	1	87.4	1
MEX02NTE	-136.20	19	-107.21	26.31	3.84	1.55	148	1	87.4	1
MEX02SUR	-127.20	19	-96.39	19.88	3.18	1.87	157	1	87.4	1
MSR00001	-79.70	19	-61.73	16.75	0.60	0.60	90	1	87.4	4
PAQPAC01	-106.20	19	-109.18	-27.53	0.60	0.60	90	1	87.4	9/GR17
PRG00002	-99.20	19	-58.66	-23.32	1.45	1.04	76	1	87.4	
PRUAND02	-115.20	19	-71.37	-4.69	6.49	2.57	87	1	87.4	9/GR5
PTRVIR01	-101.20	19	-93.94	36.32	8.24	3.56	171	1	87.4	1 6 9/GR20
PTRVIR02	-110.20	19	-95.23	36.29	8.27	3.37	168	1	87.4	1 6 9/GR21
URG00001	-71.70	19	-56.22	-32.52	1.02	0.89	11	1	87.4	
USAEH001	-61.70	19	-87.57	36.17	6.42	3.49	12	1	87.4	1 5 6
USAEH002	-101.20	19	-93.94	36.32	8.24	3.56	171	1	87.4	1 6 9/GR20
USAEH003	-110.20	19	-95.23	36.29	8.27	3.37	168	1	87.4	1 6 9/GR21
USAEH004	-119.20	19	-96.45	36.31	8.20	3.12	165	1	87.4	1 5 6
USAPSA02	-166.20	19	-109.94	36.86	6.04	1.11	137	1	87.4	9/GR1
USAPSA03	-175.20	19	-116.23	37.50	5.60	0.75	132	1	87.4	9/GR2
USAWH01	-148.20	19	-111.02	40.68	4.36	2.15	162	1	87.4	
USAWH02	-157.20	19	-113.07	40.74	3.72	1.78	149	1	87.4	
VENAND03	-115.20	19	-71.37	-4.69	6.49	2.57	87	1	87.4	9/GR5

## 17 601.02 MHz (20)

1	2	3	4		5		6	7	8	9
ALS00002	-165.80	20	-109.83	36.82	6.03	1.12	137	2	87.4	9/GR1
ALS00003	-174.80	20	-116.10	37.47	5.60	0.76	132	2	87.4	9/GR2
ARGNORT4	-93.80	20	-63.96	-30.01	3.86	1.99	48	2	87.4	
ARGNORT5	-54.80	20	-62.85	-29.80	3.24	2.89	47	2	87.4	
B CE311	-63.80	20	-40.60	-6.07	3.04	2.06	174	2	87.4	8 9/GR7
B CE312	-44.80	20	-40.26	-6.06	3.44	2.09	174	2	87.4	8 9/GR9
B CE411	-63.80	20	-50.97	-15.26	3.86	1.38	49	2	87.4	8 9/GR7
B CE412	-44.80	20	-50.71	-15.30	3.57	1.56	52	2	87.4	8 9/GR9
B CE511	-63.80	20	-53.11	-2.98	2.42	2.15	107	2	87.4	8 9/GR7
B NO611	-73.80	20	-59.60	-11.62	2.86	1.69	165	1	87.4	8 9/GR8
B NO711	-73.80	20	-60.70	-1.78	3.54	1.78	126	1	87.4	8 9/GR8
B NO811	-73.80	20	-68.75	-4.71	2.37	1.65	73	1	87.4	8 9/GR8
B SE911	-101.80	20	-45.99	-19.09	2.22	0.79	62	2	87.4	8
B SU111	-80.80	20	-51.10	-25.64	2.76	1.06	50	2	87.4	8 9/GR6
B SU112	-44.80	20	-50.76	-25.62	2.47	1.48	56	2	87.4	8 9/GR9
B SU211	-80.80	20	-44.51	-16.94	3.22	1.37	60	2	87.4	8 9/GR6
B SU212	-44.80	20	-43.99	-16.97	3.27	1.92	59	2	87.4	8 9/GR9
CAN01101	-137.80	20	-125.60	57.24	3.45	1.27	157	2	87.4	9/GR10
CAN01201	-137.80	20	-111.92	55.89	3.33	0.98	151	2	87.4	9/GR10
CAN01202	-72.30	20	-107.64	55.62	2.75	1.11	32	2	87.4	
CAN01203	-128.80	20	-111.43	55.56	3.07	1.15	151	2	87.4	9/GR12
CAN01303	-128.80	20	-102.39	57.12	3.54	0.92	154	2	87.4	9/GR12
CAN01304	-90.80	20	-99.00	57.33	1.96	1.73	1	2	87.4	9/GR13
CAN01403	-128.80	20	-89.70	52.02	4.67	0.79	148	2	87.4	9/GR12
CAN01404	-90.80	20	-84.78	52.41	3.09	2.06	153	2	87.4	9/GR13
CAN01405	-81.80	20	-84.02	52.34	2.82	2.30	172	2	87.4	9/GR14
CAN01504	-90.80	20	-72.68	53.78	3.57	1.67	157	2	87.4	9/GR13
CAN01505	-81.80	20	-71.76	53.76	3.30	1.89	162	2	87.4	9/GR14
CAN01605	-81.80	20	-61.54	49.50	2.66	1.39	144	2	87.4	9/GR14
CAN01606	-70.30	20	-61.32	49.51	2.41	1.65	148	2	87.4	
CHLCONT4	-105.80	20	-69.59	-23.20	2.21	0.69	68	2	87.4	9/GR16
CHLCONT6	-105.80	20	-73.52	-55.52	3.65	1.31	39	2	87.4	9/GR16
CRBBAH01	-92.30	20	-76.09	24.13	1.83	0.68	141	1	87.4	9/GR18
CRBBER01	-92.30	20	-64.76	32.13	0.60	0.60	90	1	87.4	9/GR18
CRBBLZ01	-92.30	20	-88.61	17.26	0.64	0.64	90	1	87.4	9/GR18
CRBEC001	-92.30	20	-60.07	8.26	4.20	0.86	115	1	87.4	9/GR18
CRBJMC01	-92.30	20	-79.45	17.97	0.99	0.68	151	1	87.4	9/GR18
EQAC0001	-94.80	20	-78.31	-1.52	1.48	1.15	65	1	87.4	9/GR19
EQAG0001	-94.80	20	-90.36	-0.57	0.94	0.89	99	1	87.4	9/GR19
GRD00003	-79.30	20	-61.62	12.34	0.60	0.60	90	2	87.4	
GTMIFRB2	-107.30	20	-90.50	15.64	1.03	0.74	84	1	87.4	
GUFMGG02	-52.80	20	-56.42	8.47	4.16	0.81	123	2	87.4	2 7
HWA00002	-165.80	20	-165.79	23.32	4.20	0.68	160	2	87.4	9/GR1
HWA00003	-174.80	20	-166.10	23.42	4.25	0.68	159	2	87.4	9/GR2
MEX01NTE	-77.80	20	-105.80	25.99	2.88	2.07	155	2	87.4	1
MEX02NTE	-135.80	20	-107.36	26.32	3.80	1.57	149	2	87.4	1
MEX02SUR	-126.80	20	-96.39	19.88	3.19	1.87	158	2	87.4	1
PNRIFRB2	-121.00	20	-80.15	8.46	1.01	0.73	170	1	87.4	
PRU00004	-85.80	20	-74.19	-8.39	3.74	2.45	112	2	87.4	
PTRVIR01	-100.80	20	-93.85	36.31	8.26	3.55	171	2	87.4	1 6 9/GR20
PTRVIR02	-109.80	20	-95.47	36.38	8.10	3.45	168	2	87.4	1 6 9/GR21
USAEH001	-61.30	20	-87.53	36.18	6.41	3.49	12	2	87.4	1 5 6
USAEH002	-100.80	20	-93.85	36.31	8.26	3.55	171	2	87.4	1 6 9/GR20
USAEH003	-109.80	20	-95.47	36.38	8.10	3.45	168	2	87.4	1 6 9/GR21
USAEH004	-118.80	20	-96.42	36.21	8.20	3.12	165	2	87.4	1 5 6
USAPSA02	-165.80	20	-109.83	36.82	6.03	1.12	137	2	87.4	9/GR1
USAPSA03	-174.80	20	-116.10	37.47	5.60	0.76	132	2	87.4	9/GR2
USAWH101	-147.80	20	-111.01	40.67	4.38	2.15	162	2	87.4	
USAWH102	-156.80	20	-113.01	40.71	3.74	1.79	149	2	87.4	
VEN02VEN	-103.80	20	-66.79	6.90	2.50	1.77	122	2	87.4	9/GR22
VEN11VEN	-103.80	20	-66.79	6.90	2.50	1.77	122	2	87.4	9/GR22

1	2	3	4	5	6	7	8	9		
ALS00002	-166.20	21	-109.94	36.86	6.04	1.11	137	1	87.4	9/GR1
ALS00003	-175.20	21	-116.23	37.50	5.60	0.75	132	1	87.4	9/GR2
ARGINSU4	-94.20	21	-52.98	-59.81	3.40	0.68	19	1	87.4	9/GR3
ARGINSU5	-55.20	21	-44.17	-59.91	3.77	0.70	13	1	87.4	9/GR4
ARGSUR04	-94.20	21	-65.04	-43.33	3.32	1.50	40	1	87.4	9/GR3
ARGSUR05	-55.20	21	-63.68	-43.01	2.54	2.38	152	1	87.4	9/GR4
B CE311	-64.20	21	-40.60	-6.07	3.04	2.06	174	1	87.4	8 9/GR7
B CE312	-45.20	21	-40.27	-6.06	3.44	2.09	174	1	87.4	8 9/GR9
B CE411	-64.20	21	-50.97	-15.27	3.86	1.38	49	1	87.4	8 9/GR7
B CE412	-45.20	21	-50.71	-15.30	3.57	1.56	52	1	87.4	8 9/GR9
B CE511	-64.20	21	-53.10	-2.90	2.44	2.13	104	1	87.4	8 9/GR7
B NO611	-74.20	21	-59.60	-11.62	2.85	1.69	165	2	87.4	8 9/GR8
B NO711	-74.20	21	-60.70	-1.78	3.54	1.78	126	2	87.4	8 9/GR8
B NO811	-74.20	21	-68.76	-4.71	2.37	1.65	73	2	87.4	8 9/GR8
B SU111	-81.20	21	-51.12	-25.63	2.76	1.05	50	1	87.4	8 9/GR6
B SU112	-45.20	21	-50.75	-25.62	2.47	1.48	56	1	87.4	8 9/GR9
B SU211	-81.20	21	-44.51	-16.95	3.22	1.36	60	1	87.4	8 9/GR6
B SU212	-45.20	21	-44.00	-16.87	3.20	1.96	58	1	87.4	8 9/GR9
BERBERMU	-96.20	21	-64.77	32.32	0.60	0.60	90	2	87.4	
BOLAND01	-115.20	21	-71.37	-4.69	6.49	2.57	87	1	87.4	9/GR5
CAN01101	-138.20	21	-125.63	57.24	3.45	1.27	157	1	87.4	9/GR10
CAN01201	-138.20	21	-112.04	55.95	3.35	0.97	151	1	87.4	9/GR10
CAN01202	-72.70	21	-107.70	55.63	2.74	1.12	32	1	87.4	
CAN01203	-129.20	21	-111.48	55.61	3.08	1.15	151	1	87.4	9/GR12
CAN01303	-129.20	21	-102.42	57.12	3.54	0.91	154	1	87.4	9/GR12
CAN01304	-91.20	21	-99.12	57.36	1.98	1.72	2	1	87.4	9/GR13
CAN01403	-129.20	21	-89.75	52.02	4.68	0.78	148	1	87.4	9/GR12
CAN01404	-91.20	21	-84.82	52.42	3.10	2.05	152	1	87.4	9/GR13
CAN01405	-82.20	21	-84.00	52.39	2.84	2.29	172	1	87.4	9/GR14
CAN01504	-91.20	21	-72.66	53.77	3.57	1.67	156	1	87.4	9/GR13
CAN01505	-82.20	21	-71.77	53.79	3.30	1.89	162	1	87.4	9/GR14
CAN01605	-82.20	21	-61.50	49.55	2.65	1.40	143	1	87.4	9/GR14
CAN01606	-70.70	21	-61.30	49.55	2.40	1.65	148	1	87.4	
CHLC0NT5	-106.20	21	-72.23	-35.57	2.60	0.68	55	1	87.4	9/GR17
CHLPAC02	-106.20	21	-80.06	-30.06	1.36	0.68	69	1	87.4	9/GR17
CLMAND01	-115.20	21	-71.37	-4.69	6.49	2.57	87	1	87.4	9/GR5
CLM00001	-103.20	21	-74.50	5.87	3.98	1.96	118	1	87.4	
EQACAND1	-115.20	21	-71.37	-4.69	6.49	2.57	87	1	87.4	9/GR5
EQAGAND1	-115.20	21	-71.37	-4.69	6.49	2.57	87	1	87.4	9/GR5
HWA00002	-166.20	21	-165.79	23.42	4.20	0.68	160	1	87.4	9/GR1
HWA00003	-175.20	21	-166.10	23.42	4.25	0.68	159	1	87.4	9/GR2
JMC00002	-92.70	21	-77.30	18.12	0.62	0.62	90	2	87.4	
KNA00001	-79.70	21	-62.46	17.44	0.60	0.60	90	1	87.4	
MEX01NTE	-78.20	21	-105.81	26.01	2.89	2.08	155	1	87.4	1
MEX01SUR	-69.20	21	-94.84	19.82	3.05	2.09	4	1	87.4	1
MEX02NTE	-136.20	21	-107.21	26.31	3.84	1.55	148	1	87.4	1
MEX02SUR	-127.20	21	-96.39	19.88	3.18	1.87	157	1	87.4	1
PAQPAC01	-106.20	21	-109.18	-27.53	0.60	0.60	90	1	87.4	9/GR17
PRG00002	-99.20	21	-58.66	-23.32	1.45	1.04	76	1	87.4	
PRUAND02	-115.20	21	-71.37	-4.69	6.49	2.57	87	1	87.4	9/GR5
PTRVIR01	-101.20	21	-93.94	36.32	8.24	3.56	171	1	87.4	1 6 9/GR20
PTRVIR02	-110.20	21	-95.23	36.29	8.27	3.37	168	1	87.4	1 6 9/GR21
SPMFRAN3	-53.20	21	-67.24	47.51	3.16	0.79	7	1	87.4	2 7
SURINAM2	-84.70	21	-55.69	4.35	1.00	0.69	86	1	87.4	
URG00001	-71.70	21	-56.22	-32.52	1.02	0.89	11	1	87.4	
USAEH001	-61.70	21	-87.57	36.17	6.42	3.49	12	1	87.4	1 5 6
USAEH002	-101.20	21	-93.94	36.32	8.24	3.56	171	1	87.4	1 6 9/GR20
USAEH003	-110.20	21	-95.23	36.29	8.27	3.37	168	1	87.4	1 6 9/GR21
USAEH004	-119.20	21	-96.45	36.21	8.20	3.12	165	1	87.4	1 5 6
USAPSA02	-166.20	21	-109.94	36.86	6.04	1.11	137	1	87.4	9/GR1
USAPSA03	-175.20	21	-116.23	37.50	5.60	0.75	132	1	87.4	9/GR2
USAWH101	-148.20	21	-111.02	40.68	4.36	2.15	162	1	87.4	
USAWH102	-157.20	21	-113.07	40.74	3.72	1.78	149	1	87.4	
VENAND03	-115.20	21	-71.37	-4.69	6.49	2.57	87	1	87.4	9/GR5

17 630.18 MHz (22)

1	2	3	4	5	6	7	8	9		
ALS00002	-165.80	22	-109.83	36.82	6.03	1.12	137	2	87.4	9/GR1
ALS00003	-174.80	22	-116.10	37.47	5.60	0.76	132	2	87.4	9/GR2
ARGNORT4	-93.80	22	-63.96	-30.01	3.86	1.99	48	2	87.4	
ARGNORT5	-54.80	22	-62.85	-29.80	3.24	2.89	47	2	87.4	
ATNBEM1	-52.80	22	-66.44	14.87	1.83	0.68	39	2	87.4	
B CE311	-63.80	22	-40.60	-6.07	3.04	2.06	174	2	87.4	8 9/GR7
B CE312	-44.80	22	-40.26	-6.06	3.44	2.09	174	2	87.4	8 9/GR9
B CE411	-63.80	22	-50.97	-15.26	3.86	1.38	49	2	87.4	8 9/GR7
B CE412	-44.80	22	-50.71	-15.30	3.57	1.56	52	2	87.4	8 9/GR9
B CE511	-63.80	22	-53.11	-2.98	2.42	2.15	107	2	87.4	8 9/GR7
B NO611	-73.80	22	-59.60	-11.62	2.86	1.69	165	1	87.4	8 9/GR8
B NO711	-73.80	22	-60.70	-1.78	3.54	1.78	126	1	87.4	8 9/GR8
B NO811	-73.80	22	-68.75	-4.71	2.37	1.65	73	1	87.4	8 9/GR8
B SE911	-101.80	22	-45.99	-19.09	2.22	0.79	62	2	87.4	8
B SU111	-80.80	22	-51.10	-25.64	2.76	1.06	50	2	87.4	8 9/GR6
B SU112	-44.80	22	-50.76	-25.62	2.47	1.48	56	2	87.4	8 9/GR9
B SU211	-80.80	22	-44.51	-16.94	3.22	1.37	60	2	87.4	8 9/GR6
B SU212	-44.80	22	-43.99	-16.97	3.27	1.92	59	2	87.4	8 9/GR9
BLZ0001	-115.80	22	-88.68	17.27	0.62	0.62	90	2	87.4	
CAN01101	-137.80	22	-125.60	57.24	3.45	1.27	157	2	87.4	9/GR10
CAN01201	-137.80	22	-111.92	55.89	3.33	0.98	151	2	87.4	9/GR10
CAN01202	-72.30	22	-107.64	55.62	2.75	1.11	32	2	87.4	
CAN01203	-128.80	22	-111.43	55.56	3.07	1.15	151	2	87.4	9/GR12
CAN01303	-128.80	22	-102.39	57.12	3.54	0.92	154	2	87.4	9/GR12
CAN01304	-90.80	22	-99.00	57.33	1.96	1.73	1	2	87.4	9/GR13
CAN01403	-128.80	22	-89.70	52.02	4.67	0.79	148	2	87.4	9/GR12
CAN01404	-90.80	22	-84.78	52.41	3.09	2.06	153	2	87.4	9/GR13
CAN01405	-81.80	22	-84.02	52.34	2.82	2.30	172	2	87.4	9/GR14
CAN01504	-90.80	22	-72.68	53.78	3.57	1.67	157	2	87.4	9/GR13
CAN01505	-81.80	22	-71.76	53.76	3.30	1.89	162	2	87.4	9/GR14
CAN01605	-81.80	22	-61.54	49.50	2.66	1.39	144	2	87.4	9/GR14
CAN01606	-70.30	22	-61.32	49.51	2.41	1.65	148	2	87.4	
CHLCONT4	-105.80	22	-69.59	-23.20	2.21	0.69	68	2	87.4	9/GR16
CHLCONT7	-105.80	22	-73.52	-55.52	3.65	1.31	39	2	87.4	9/GR16
CRBBAH01	-92.30	22	-76.09	24.13	1.83	0.68	141	1	87.4	9/GR18
CRBBER01	-92.30	22	-64.76	32.13	0.60	0.60	90	1	87.4	9/GR18
CRBBLZ01	-92.30	22	-88.61	17.26	0.64	0.64	90	1	87.4	9/GR18
CRBEC001	-92.30	22	-60.07	8.26	4.20	0.86	115	1	87.4	9/GR18
CRBJMCO1	-92.30	22	-79.45	17.97	0.99	0.68	151	1	87.4	9/GR18
CTR00201	-130.80	22	-84.33	9.67	0.82	0.68	119	2	87.4	
DMAIFRB1	-79.30	22	-61.30	15.35	0.60	0.60	90	2	87.4	
EQAC0001	-94.80	22	-78.31	-1.52	1.48	1.15	65	1	87.4	9/GR19
EQAG0001	-94.80	22	-90.36	-0.57	0.94	0.89	99	1	87.4	9/GR19
HWAA0002	-165.80	22	-165.79	23.32	4.20	0.68	160	2	87.4	9/GR1
HWAA0003	-174.80	22	-166.10	23.42	4.25	0.68	159	2	87.4	9/GR2
MEX01NTE	-77.80	22	-105.80	25.99	2.88	2.07	155	2	87.4	1
MEX02NTE	-135.80	22	-107.36	26.32	3.80	1.57	149	2	87.4	1
MEX02SUR	-126.80	22	-96.39	19.88	3.19	1.87	158	2	87.4	1
NCG00003	-107.30	22	-84.99	12.90	1.05	1.01	176	1	87.4	
PRU00004	-85.80	22	-74.19	-8.39	3.74	2.45	112	2	87.4	
PTRVIR01	-100.80	22	-93.85	36.31	8.26	3.55	171	2	87.4	1 6 9/GR20
PTRVIR02	-109.80	22	-95.47	36.38	8.10	3.45	168	2	87.4	1 6 9/GR21
USAEH001	-61.30	22	-87.53	36.18	6.41	3.49	12	2	87.4	1 5 6
USAEH002	-100.80	22	-93.85	36.31	8.26	3.55	171	2	87.4	1 6 9/GR20
USAEH003	-109.80	22	-95.47	36.38	8.10	3.45	168	2	87.4	1 6 9/GR21
USAEH004	-118.80	22	-96.42	36.21	8.20	3.12	165	2	87.4	1 5 6
USAPSA02	-165.80	22	-109.83	36.82	6.03	1.12	137	2	87.4	9/GR1
USAPSA03	-174.80	22	-116.10	37.47	5.60	0.76	132	2	87.4	9/GR2
USAWH01	-147.80	22	-111.01	40.67	4.38	2.15	162	2	87.4	
USAWH102	-156.80	22	-113.01	40.71	3.74	1.79	149	2	87.4	
VEN11VEN	-103.80	22	-66.79	6.90	2.50	1.77	122	2	87.4	

1	2	3	4	5	6	7	8	9		
ALS00002	-166.20	23	-109.94	36.86	6.04	1.11	137	1	87.4	9/GR1
ALS00003	-175.20	23	-116.23	37.50	5.60	0.75	132	1	87.4	9/GR2
ARGINSU4	-94.20	23	-52.98	-59.81	3.40	0.68	19	1	87.4	9/GR3
ARGINSU5	-55.20	23	-44.17	-59.91	3.77	0.70	13	1	87.4	9/GR4
ARGSUR04	-94.20	23	-65.04	-43.33	3.32	1.50	40	1	87.4	9/GR3
ARGSUR05	-55.20	23	-63.68	-43.01	2.54	2.38	152	1	87.4	9/GR4
B CE311	-64.20	23	-40.60	-6.07	3.04	2.06	174	1	87.4	8 9/GR7
B CE312	-45.20	23	-40.27	-6.06	3.44	2.09	174	1	87.4	8 9/GR9
B CE411	-64.20	23	-50.97	-15.27	3.86	1.38	49	1	87.4	8 9/GR7
B CE412	-45.20	23	-50.71	-15.30	3.57	1.56	52	1	87.4	8 9/GR9
B CE511	-64.20	23	-53.10	-2.90	2.44	2.13	104	1	87.4	8 9/GR7
B NO611	-74.20	23	-59.60	-11.62	2.85	1.69	165	2	87.4	8 9/GR8
B NO711	-74.20	23	-60.70	-1.78	3.54	1.78	126	2	87.4	8 9/GR8
B NO811	-74.20	23	-68.76	-4.71	2.37	1.65	73	2	87.4	8 9/GR8
B SU111	-81.20	23	-51.12	-25.63	2.76	1.05	50	1	87.4	8 9/GR6
B SU112	-45.20	23	-50.75	-25.62	2.47	1.48	56	1	87.4	8 9/GR9
B SU211	-81.20	23	-44.51	-16.95	3.22	1.36	60	1	87.4	8 9/GR6
B SU212	-45.20	23	-44.00	-16.87	3.20	1.96	58	1	87.4	8 9/GR9
BERBERMU	-96.20	23	-64.77	32.32	0.60	0.60	90	2	87.4	
BOLAND01	-115.20	23	-71.37	-4.69	6.49	2.57	87	1	87.4	9/GR5
BOL00001	-87.20	23	-64.61	-16.71	2.52	2.19	85	1	87.4	
BRB00001	-92.70	23	-59.85	12.93	0.60	0.60	90	2	87.4	
CAN01101	-138.20	23	-125.63	57.24	3.45	1.27	157	1	87.4	9/GR10
CAN01201	-138.20	23	-112.04	55.95	3.35	0.97	151	1	87.4	9/GR10
CAN01202	-72.70	23	-107.70	55.63	2.74	1.12	32	1	87.4	
CAN01203	-129.20	23	-111.48	55.61	3.08	1.15	151	1	87.4	9/GR12
CAN01303	-129.20	23	-102.42	57.12	3.54	0.91	154	1	87.4	9/GR12
CAN01304	-91.20	23	-99.12	57.36	1.98	1.72	2	1	87.4	9/GR13
CAN01403	-129.20	23	-89.75	52.02	4.68	0.78	148	1	87.4	9/GR12
CAN01404	-91.20	23	-84.82	52.42	3.10	2.05	152	1	87.4	9/GR13
CAN01405	-82.20	23	-84.00	52.39	2.84	2.29	172	1	87.4	9/GR14
CAN01504	-91.20	23	-72.66	53.77	3.57	1.67	156	1	87.4	9/GR13
CAN01505	-82.20	23	-71.77	53.79	3.30	1.89	162	1	87.4	9/GR14
CAN01605	-82.20	23	-61.50	49.55	2.65	1.40	143	1	87.4	9/GR14
CAN01606	-70.70	23	-61.30	49.55	2.40	1.65	148	1	87.4	
CHLCONT5	-106.20	23	-72.23	-35.57	2.60	0.68	55	1	87.4	9/GR17
CHLPAC02	-106.20	23	-80.06	-30.06	1.36	0.68	69	1	87.4	9/GR17
CLMAND01	-115.20	23	-71.37	-4.69	6.49	2.57	87	1	87.4	9/GR5
CLM00001	-103.20	23	-74.50	5.87	3.98	1.96	118	1	87.4	
CUB00001	-89.20	23	-79.81	21.62	2.24	0.68	168	1	87.4	
EQACAND1	-115.20	23	-71.37	-4.69	6.49	2.57	87	1	87.4	9/GR5
EQAGAND1	-115.20	23	-71.37	-4.69	6.49	2.57	87	1	87.4	9/GR5
GRD00059	-57.20	23	-61.58	12.29	0.60	0.60	90	1	87.4	
GRLDNK01	-53.20	23	-44.89	66.56	2.70	0.82	173	1	87.4	2
GUY00201	-84.70	23	-59.19	4.78	1.44	0.85	95	1	87.4	
HWA00002	-166.20	23	-165.79	23.42	4.20	0.68	160	1	87.4	9/GR1
HWA00003	-175.20	23	-166.10	23.42	4.25	0.68	159	1	87.4	9/GR2
MEX01NTE	-78.20	23	-105.81	26.01	2.89	2.08	155	1	87.4	1
MEX01SUR	-69.20	23	-94.84	19.82	3.05	2.09	4	1	87.4	1
MEX02NTE	-136.20	23	-107.21	26.31	3.84	1.55	148	1	87.4	1
MEX02SUR	-127.20	23	-96.39	19.88	3.18	1.87	157	1	87.4	1
MSR00001	-79.70	23	-61.73	16.75	0.60	0.60	90	1	87.4	4
PAQPAC01	-106.20	23	-109.18	-27.53	0.60	0.60	90	1	87.4	9/GR17
PRG00002	-99.20	23	-58.66	-23.32	1.45	1.04	76	1	87.4	
PRUAND02	-115.20	23	-71.37	-4.69	6.49	2.57	87	1	87.4	9/GR5
PTRVIR01	-101.20	23	-93.94	36.32	8.24	3.56	171	1	87.4	1 6 9/GR20
PTRVIR02	-110.20	23	-95.23	36.29	8.27	3.37	168	1	87.4	1 6 9/GR21
URG00001	-71.70	23	-56.22	-32.52	1.02	0.89	11	1	87.4	
USAEH001	-61.70	23	-87.57	36.17	6.42	3.49	12	1	87.4	1 5 6
USAEH002	-101.20	23	-93.94	36.32	8.24	3.56	171	1	87.4	1 6 9/GR20
USAEH003	-110.20	23	-95.23	36.29	8.27	3.37	168	1	87.4	1 6 9/GR21
USAEH004	-119.20	23	-96.45	36.21	8.20	3.12	165	1	87.4	1 5 6
USAPSA02	-166.20	23	-109.94	36.86	6.04	1.11	137	1	87.4	9/GR1
USAPSA03	-175.20	23	-116.23	37.50	5.60	0.75	132	1	87.4	9/GR2
USAWH01	-148.20	23	-111.02	40.68	4.36	2.15	162	1	87.4	
USAWH02	-157.20	23	-113.07	40.74	3.72	1.78	149	1	87.4	
VENAND03	-115.20	23	-71.37	-4.69	6.49	2.57	87	1	87.4	9/GR5

17 659.34 MHz (24)

1	2	3	4	5	6	7	8	9		
ALS00002	-165.80	24	-109.83	36.82	6.03	1.12	137	2	87.4	9/GR1
ALS00003	-174.80	24	-116.10	37.47	5.60	0.76	132	2	87.4	9/GR2
ARGNORT4	-93.80	24	-63.96	-30.01	3.86	1.99	48	2	87.4	
ARGNORT5	-54.80	24	-62.85	-29.80	3.24	2.89	47	2	87.4	
B CE311	-63.80	24	-40.60	-6.07	3.04	2.06	174	2	87.4	8 9/GR7
B CE312	-44.80	24	-40.26	-6.06	3.44	2.09	174	2	87.4	8 9/GR9
B CE411	-63.80	24	-50.97	-15.26	3.86	1.38	49	2	87.4	8 9/GR7
B CE412	-44.80	24	-50.71	-15.30	3.57	1.56	52	2	87.4	8 9/GR9
B CE511	-63.80	24	-53.11	-2.98	2.42	2.15	107	2	87.4	8 9/GR7
B NO611	-73.80	24	-59.60	-11.62	2.86	1.69	165	1	87.4	8 9/GR8
B NO711	-73.80	24	-60.70	-1.78	3.54	1.78	126	1	87.4	8 9/GR8
B NO811	-73.80	24	-68.75	-4.71	2.37	1.65	73	1	87.4	8 9/GR8
B SE911	-101.80	24	-45.99	-19.09	2.22	0.79	62	2	87.4	8
B SU111	-80.80	24	-51.10	-25.64	2.76	1.06	50	2	87.4	8 9/GR6
B SU112	-44.80	24	-50.76	-25.62	2.47	1.48	56	2	87.4	8 9/GR9
B SU211	-80.80	24	-44.51	-16.94	3.22	1.37	60	2	87.4	8 9/GR6
B SU212	-44.80	24	-43.99	-16.97	3.27	1.92	59	2	87.4	8 9/GR9
CAN01101	-137.80	24	-125.60	57.24	3.45	1.27	157	2	87.4	9/GR10
CAN01201	-137.80	24	-111.92	55.89	3.33	0.98	151	2	87.4	9/GR10
CAN01202	-72.30	24	-107.64	55.62	2.75	1.11	32	2	87.4	
CAN01203	-128.80	24	-111.43	55.56	3.07	1.15	151	2	87.4	9/GR12
CAN01303	-128.80	24	-102.39	57.12	3.54	0.92	154	2	87.4	9/GR12
CAN01304	-90.80	24	-99.00	57.33	1.96	1.73	1	2	87.4	9/GR13
CAN01403	-128.80	24	-89.70	52.02	4.67	0.79	148	2	87.4	9/GR12
CAN01404	-90.80	24	-84.78	52.41	3.09	2.06	153	2	87.4	9/GR13
CAN01405	-81.80	24	-84.02	52.34	2.82	2.30	172	2	87.4	9/GR14
CAN01504	-90.80	24	-72.68	53.78	3.57	1.67	157	2	87.4	9/GR13
CAN01505	-81.80	24	-71.76	53.76	3.30	1.89	162	2	87.4	9/GR14
CAN01605	-81.80	24	-61.54	49.50	2.66	1.39	144	2	87.4	9/GR14
CAN01606	-70.30	24	-61.32	49.51	2.41	1.65	148	2	87.4	
CHLCONT4	-105.80	24	-69.59	-23.20	2.21	0.69	68	2	87.4	9/GR16
CHLCONT6	-105.80	24	-73.52	-55.52	3.65	1.31	39	2	87.4	9/GR16
CRBBAH01	-92.30	24	-76.09	24.13	1.83	0.68	141	1	87.4	9/GR18
CRBBER01	-92.30	24	-64.76	32.13	0.60	0.60	90	1	87.4	9/GR18
CRBBLZ01	-92.30	24	-88.61	17.26	0.64	0.64	90	1	87.4	9/GR18
CRBEC001	-92.30	24	-60.07	8.26	4.20	0.86	115	1	87.4	9/GR18
CRBJMC01	-92.30	24	-79.45	17.97	0.99	0.68	151	1	87.4	9/GR18
EQAC0001	-94.80	24	-78.31	-1.52	1.48	1.15	65	1	87.4	9/GR19
EQAG0001	-94.80	24	-90.36	-0.57	0.94	0.89	99	1	87.4	9/GR19
GRD00003	-79.30	24	-61.62	12.34	0.60	0.60	90	2	87.4	
GTMIFRB2	-107.30	24	-90.50	15.64	1.03	0.74	84	1	87.4	
GUFMGG02	-52.80	24	-56.42	8.47	4.16	0.81	123	2	87.4	2 7
HWA00002	-165.80	24	-165.79	23.32	4.20	0.68	160	2	87.4	9/GR1
HWA00003	-174.80	24	-166.10	23.42	4.25	0.68	159	2	87.4	9/GR1
MEX01NTE	-77.80	24	-105.80	25.99	2.88	2.07	155	2	87.4	1
MEX02NTE	-135.80	24	-107.36	26.32	3.80	1.57	149	2	87.4	1
MEX02SUR	-126.80	24	-96.39	19.88	3.19	1.87	158	2	87.4	1
PNRIFRB2	-121.00	24	-80.15	8.46	1.01	0.73	170	1	87.4	
PRU00004	-85.80	24	-74.19	-8.39	3.74	2.45	112	2	87.4	
PTRVIR01	-100.80	24	-93.85	36.31	8.26	3.55	171	2	87.4	1 6 9/GR20
PTRVIR02	-109.80	24	-95.47	36.38	8.10	3.45	168	2	87.4	1 6 9/GR21
USAEH001	-61.30	24	-87.53	36.18	6.41	3.49	12	2	87.4	1 5 6
USAEH002	-100.80	24	-93.85	36.31	8.26	3.55	171	2	87.4	1 6 9/GR20
USAEH003	-109.80	24	-95.47	36.38	8.10	3.45	168	2	87.4	1 6 9/GR21
USAEH004	-118.80	24	-96.42	36.21	8.20	3.12	165	2	87.4	1 5 6
USAPSA02	-165.80	24	-109.83	36.82	6.03	1.12	137	2	87.4	9/GR1
USAPSA03	-174.80	24	-116.10	37.47	5.60	0.76	132	2	87.4	9/GR2
USAWH101	-147.80	24	-111.01	40.67	4.38	2.15	162	2	87.4	
USAWH102	-156.80	24	-113.01	40.71	3.74	1.79	149	2	87.4	
VEN02VEN	-103.80	24	-66.79	6.90	2.50	1.77	122	2	87.4	9/GR22
VEN11VEN	-103.80	24	-66.79	6.90	2.50	1.77	122	2	87.4	9/GR22



1	2	3	4	5	6	7	8	9		
ALS00002	-166.20	25	-109.94	36.86	6.04	1.11	137	1	87.4	9/GR1
ALS00003	-175.20	25	-116.23	37.50	5.60	0.75	132	1	87.4	9/GR2
ARGINSU4	-94.20	25	-52.98	-59.81	3.40	0.68	19	1	87.4	9/GR3
ARGINSU5	-55.20	25	-44.17	-59.91	3.77	0.70	13	1	87.4	9/GR4
ARGSUR04	-94.20	25	-65.04	-43.33	3.32	1.50	40	1	87.4	9/GR3
ARGSUR05	-55.20	25	-63.68	-43.01	2.54	2.38	152	1	87.4	9/GR4
B CE311	-64.20	25	-40.60	-6.07	3.04	2.06	174	1	87.4	8 9/GR7
B CE312	-45.20	25	-40.27	-6.06	3.44	2.09	174	1	87.4	8 9/GR7
B CE411	-64.20	25	-50.97	-15.27	3.86	1.38	49	1	87.4	8 9/GR7
B CE412	-45.20	25	-50.71	-15.30	3.57	1.56	52	1	87.4	8 9/GR9
B CE511	-64.20	25	-53.10	-2.90	2.44	2.13	104	1	87.4	8 9/GR7
B NO611	-74.20	25	-59.60	-11.62	2.85	1.69	165	2	87.4	8 9/GR8
B NO711	-74.20	25	-60.70	-1.78	3.54	1.78	126	2	87.4	8 9/GR8
B NO811	-74.20	25	-68.76	-4.71	2.37	1.65	73	2	87.4	8 9/GR8
B SU111	-81.20	25	-51.12	-25.63	2.76	1.05	50	1	87.4	8 9/GR6
B SU112	-45.20	25	-50.75	-25.62	2.47	1.48	56	1	87.4	8 9/GR9
B SU211	-81.20	25	-44.51	-16.95	3.22	1.36	60	1	87.4	8 9/GR6
B SU212	-45.20	25	-44.00	-16.87	3.20	1.96	58	1	87.4	8 9/GR9
BERBERMU	-96.20	25	-64.77	32.32	0.60	0.60	90	2	87.4	
BOLAND01	-115.20	25	-71.37	-4.69	6.49	2.57	87	1	87.4	9/GR5
CAN01101	-138.20	25	-125.63	57.24	3.45	1.27	157	1	87.4	9/GR10
CAN01201	-138.20	25	-112.04	55.95	3.35	0.97	151	1	87.4	9/GR10
CAN01202	-72.70	25	-107.70	55.63	2.74	1.12	32	1	87.4	
CAN01203	-129.20	25	-111.48	55.61	3.08	1.15	151	1	87.4	9/GR12
CAN01303	-129.20	25	-102.42	57.12	3.54	0.91	154	1	87.4	9/GR12
CAN01304	-91.20	25	-99.12	57.36	1.98	1.72	2	1	87.4	9/GR13
CAN01403	-129.20	25	-89.75	52.02	4.68	0.78	148	1	87.4	9/GR12
CAN01404	-91.20	25	-84.82	52.42	3.10	2.05	152	1	87.4	9/GR13
CAN01405	-82.20	25	-84.00	52.39	2.84	2.29	172	1	87.4	9/GR14
CAN01504	-91.20	25	-72.66	53.77	3.57	1.67	156	1	87.4	9/GR13
CAN01505	-82.20	25	-71.77	53.79	3.30	1.89	162	1	87.4	9/GR14
CAN01605	-82.20	25	-61.50	49.55	2.65	1.40	143	1	87.4	9/GR14
CAN01606	-70.70	25	-61.30	49.55	2.40	1.65	148	1	87.4	
CHLCONT5	-106.20	25	-72.23	-35.57	2.60	0.68	55	1	87.4	9/GR17
CHLPAC02	-106.20	25	-80.06	-30.06	1.36	0.68	69	1	87.4	9/GR17
CLMAND01	-115.20	25	-71.37	-4.69	6.49	2.57	87	1	87.4	9/GR5
CLM00001	-103.20	25	-74.50	5.87	3.98	1.96	118	1	87.4	
EQACAND1	-115.20	25	-71.37	-4.69	6.49	2.57	87	1	87.4	9/GR5
EQAGAND1	-115.20	25	-71.37	-4.69	6.49	2.57	87	1	87.4	9/GR5
HWA00002	-166.20	25	-165.79	23.42	4.20	0.68	160	1	87.4	9/GR1
HWA00003	-175.20	25	-166.10	23.42	4.25	0.68	159	1	87.4	9/GR2
JMC00002	-92.70	25	-77.30	18.12	0.62	0.62	90	2	87.4	
KNA00001	-79.70	25	-62.46	17.44	0.60	0.60	90	1	87.4	
MEX01NTE	-78.20	25	-105.81	26.01	2.89	2.08	155	1	87.4	1
MEX01SUR	-69.20	25	-94.84	19.82	3.05	2.09	4	1	87.4	1
MEX02NTE	-136.20	25	-107.21	26.31	3.84	1.55	148	1	87.4	1
MEX02SUR	-127.20	25	-96.39	19.88	3.18	1.87	157	1	87.4	1
PAQPAC01	-106.20	25	-109.18	-27.53	0.60	0.60	90	1	87.4	9/GR17
PRG00002	-99.20	25	-58.66	-23.32	1.45	1.04	76	1	87.4	
PRUAND02	-115.20	25	-71.37	-4.69	6.49	2.57	87	1	87.4	9/GR5
PTRVIR01	-101.20	25	-93.94	36.32	8.24	3.56	171	1	87.4	1 6 9/GR20
PTRVIR02	-110.20	25	-95.23	36.29	8.27	3.37	168	1	87.4	1 6 9/GR21
SPMFRAN3	-53.20	25	-67.24	47.51	3.16	0.79	7	1	87.4	2 7
SURINAM2	-84.70	25	-55.69	4.35	1.00	0.69	86	1	87.4	
URG00001	-71.70	25	-56.22	-32.52	1.02	0.89	11	1	87.4	
USAEH001	-61.70	25	-87.57	36.17	6.42	3.49	12	1	87.4	1 5 6
USAEH002	-101.20	25	-93.94	36.32	8.24	3.56	171	1	87.4	1 6 9/GR20
USAEH003	-110.20	25	-95.23	36.29	8.27	3.37	168	1	87.4	1 6 9/GR21
USAEH004	-119.20	25	-96.45	36.21	8.20	3.12	165	1	87.4	1 5 6
USAPSA02	-166.20	25	-109.94	36.86	6.04	1.11	137	1	87.4	9/GR1
USAPSA03	-175.20	25	-116.23	37.50	5.60	0.75	132	1	87.4	9/GR2
USAWH101	-148.20	25	-111.02	40.68	4.36	2.15	162	1	87.4	
USAWH102	-157.20	25	-113.07	40.74	3.72	1.78	149	1	87.4	
VENAND03	-115.20	25	-71.37	-4.69	6.49	2.57	87	1	87.4	9/GR5

17 688.50 MHz (26)

1	2	3	4	5	6	7	8	9		
ALS00002	-165.80	26	-109.83	36.82	6.03	1.12	137	2	87.4	9/GR1
ALS00003	-174.80	26	-116.10	37.47	5.60	0.76	132	2	87.4	9/GR2
ARGNORT4	-93.80	26	-63.96	-30.01	3.86	1.99	48	2	87.4	
ARGNORT5	-54.80	26	-62.85	-29.80	3.24	2.89	47	2	87.4	
ATNBEM1	-52.80	26	-66.44	14.87	1.83	0.68	39	2	87.4	
B CE311	-63.80	26	-40.60	-6.07	3.04	2.06	174	2	87.4	8 9/GR7
B CE312	-44.80	26	-40.26	-6.06	3.44	2.09	174	2	87.4	8 9/GR9
B CE411	-63.80	26	-50.97	-15.26	3.86	1.38	49	2	87.4	8 9/GR7
B CE412	-44.80	26	-50.71	-15.30	3.57	1.56	52	2	87.4	8 9/GR9
B CE511	-63.80	26	-53.11	-2.98	2.42	2.15	107	2	87.4	8 9/GR7
B NO611	-73.80	26	-59.60	-11.62	2.86	1.69	165	1	87.4	8 9/GR8
B NO711	-73.80	26	-60.70	-1.78	3.54	1.78	126	1	87.4	8 9/GR8
B NO811	-73.80	26	-68.75	-4.71	2.37	1.65	73	1	87.4	8 9/GR8
B SE911	-101.80	26	-45.99	-19.09	2.22	0.79	62	2	87.4	8
B SU111	-80.80	26	-51.10	-25.64	2.76	1.06	50	2	87.4	8 9/GR6
B SU112	-44.80	26	-50.76	-25.62	2.47	1.48	56	2	87.4	8 9/GR9
B SU211	-80.80	26	-44.51	-16.94	3.22	1.37	60	2	87.4	8 9/GR6
B SU212	-44.80	26	-43.99	-16.97	3.27	1.92	59	2	87.4	8 9/GR9
BLZ0001	-115.80	26	-88.68	17.27	0.62	0.62	90	2	87.4	
CAN01101	-137.80	26	-125.60	57.24	3.45	1.27	157	2	87.4	9/GR10
CAN01201	-137.80	26	-111.92	55.89	3.33	0.98	151	2	87.4	9/GR10
CAN01202	-72.30	26	-107.64	55.62	2.75	1.11	32	2	87.4	
CAN01203	-128.80	26	-111.43	55.56	3.07	1.15	151	2	87.4	9/GR12
CAN01303	-128.80	26	-102.39	57.12	3.54	0.92	154	2	87.4	9/GR12
CAN01304	-90.80	26	-99.00	57.33	1.96	1.73	1	2	87.4	9/GR13
CAN01403	-128.80	26	-89.70	52.02	4.67	0.79	148	2	87.4	9/GR12
CAN01404	-90.80	26	-84.78	52.41	3.09	2.06	153	2	87.4	9/GR13
CAN01405	-81.80	26	-84.02	52.34	2.82	2.30	172	2	87.4	9/GR14
CAN01504	-90.80	26	-72.68	53.78	3.57	1.67	157	2	87.4	9/GR13
CAN01505	-81.80	26	-71.76	53.76	3.30	1.89	162	2	87.4	9/GR14
CAN01605	-81.80	26	-61.54	49.50	2.66	1.39	144	2	87.4	9/GR14
CAN01606	-70.30	26	-61.32	49.51	2.41	1.65	148	2	87.4	
CHLCONT4	-105.80	26	-69.59	-23.20	2.21	0.69	68	2	87.4	9/GR16
CHLCONT7	-105.80	26	-73.52	-55.52	3.65	1.31	39	2	87.4	9/GR16
CRBBAH01	-92.30	26	-76.09	24.13	1.83	0.68	141	1	87.4	9/GR18
CRBBER01	-92.30	26	-64.76	32.13	0.60	0.60	90	1	87.4	9/GR18
CRBBLZ01	-92.30	26	-88.61	17.26	0.64	0.64	90	1	87.4	9/GR18
CRBEC001	-92.30	26	-60.07	8.26	4.20	0.86	115	1	87.4	9/GR18
CRBJMC01	-92.30	26	-79.45	17.97	0.99	0.68	151	1	87.4	9/GR18
CTR00201	-130.80	26	-84.33	9.67	0.82	0.68	119	2	87.4	
DMAIFRB1	-79.30	26	-61.30	15.35	0.60	0.60	90	2	87.4	
EQAC0001	-94.80	26	-78.31	-1.52	1.48	1.15	65	1	87.4	9/GR19
EQAG0001	-94.80	26	-90.36	-0.57	0.94	0.89	99	1	87.4	9/GR19
HWAA0002	-165.80	26	-165.79	23.32	4.20	0.68	160	2	87.4	9/GR1
HWAA0003	-174.80	26	-166.10	23.42	4.25	0.68	159	2	87.4	9/GR2
MEX01NTE	-77.80	26	-105.80	25.99	2.88	2.07	155	2	87.4	1
MEX02NTE	-135.80	26	-107.36	26.32	3.80	1.57	149	2	87.4	1
MEX02SUR	-126.80	26	-96.39	19.88	3.19	1.87	158	2	87.4	1
NCG00003	-107.30	26	-84.99	12.90	1.05	1.01	176	1	87.4	
PRU00004	-85.80	26	-74.19	-8.39	3.74	2.45	112	2	87.4	
PTRVIR01	-100.80	26	-93.85	36.31	8.26	3.55	171	2	87.4	1 6 9/GR20
PTRVIR02	-109.80	26	-95.47	36.38	8.10	3.45	168	2	87.4	1 6 9/GR21
USAEH001	-61.30	26	-87.53	36.18	6.41	3.49	12	2	87.4	1 5 6
USAEH002	-100.80	26	-93.85	36.31	8.26	3.55	171	2	87.4	1 6 9/GR20
USAEH003	-109.80	26	-95.47	36.38	8.10	3.45	168	2	87.4	1 6 9/GR21
USAEH004	-118.80	26	-96.42	36.21	8.20	3.12	165	2	87.4	1 5 6
USAPSA02	-165.80	26	-109.83	36.82	6.03	1.12	137	2	87.4	9/GR1
USAPSA03	-174.80	26	-116.10	37.47	5.60	0.76	132	2	87.4	9/GR2
USAWH01	-147.80	26	-111.01	40.67	4.38	2.15	162	2	87.4	
USAWH102	-156.80	26	-113.01	40.71	3.74	1.79	149	2	87.4	
VEN11VEN	-103.80	26	-66.79	6.90	2.50	1.77	122	2	87.4	

1	2	3	4	5	6	7	8	9		
ALS00002	-166.20	27	-109.94	36.86	6.04	1.11	137	1	87.4	9/GR1
ALS00003	-175.20	27	-116.23	37.50	5.60	0.75	132	1	87.4	9/GR2
ARGINSU4	-94.20	27	-52.98	-59.81	3.40	0.68	19	1	87.4	9/GR3
ARGINSU5	-55.20	27	-44.17	-59.91	3.77	0.70	13	1	87.4	9/GR4
ARGSUR04	-94.20	27	-65.04	-43.33	3.32	1.50	40	1	87.4	9/GR3
ARGSUR05	-55.20	27	-63.68	-43.01	2.54	2.38	152	1	87.4	9/GR4
B CE311	-64.20	27	-40.60	-6.07	3.04	2.06	174	1	87.4	8 9/GR7
B CE312	-45.20	27	-40.27	-6.06	3.44	2.09	174	1	87.4	8 9/GR9
B CE411	-64.20	27	-50.97	-15.27	3.86	1.38	49	1	87.4	8 9/GR7
B CE412	-45.20	27	-50.71	-15.30	3.57	1.56	52	1	87.4	8 9/GR9
B CE511	-64.20	27	-53.10	-2.90	2.44	2.13	104	1	87.4	8 9/GR7
B NO611	-74.20	27	-59.60	-11.62	2.85	1.69	165	2	87.4	8 9/GR8
B NO711	-74.20	27	-60.70	-1.78	3.54	1.78	126	2	87.4	8 9/GR8
B NO811	-74.20	27	-68.76	-4.71	2.37	1.65	73	2	87.4	8 9/GR8
B SU111	-81.20	27	-51.12	-25.63	2.76	1.05	50	1	87.4	8 9/GR6
B SU112	-45.20	27	-50.75	-25.62	2.47	1.48	56	1	87.4	8 9/GR9
B SU211	-81.20	27	-44.51	-16.95	3.22	1.36	60	1	87.4	8 9/GR6
B SU212	-45.20	27	-44.00	-16.87	3.20	1.96	58	1	87.4	8 9/GR9
BERBERMU	-96.20	27	-64.77	32.32	0.60	0.60	90	2	87.4	
BOLAND01	-115.20	27	-71.37	-4.69	6.49	2.57	87	1	87.4	9/GR5
BOL00001	-87.20	27	-64.61	-16.71	2.52	2.19	85	1	87.4	
BRB00001	-92.70	27	-59.85	12.93	0.60	0.60	90	2	87.4	
CAN01101	-138.20	27	-125.63	57.24	3.45	1.27	157	1	87.4	9/GR10
CAN01201	-138.20	27	-112.04	55.95	3.35	0.97	151	1	87.4	9/GR10
CAN01202	-72.70	27	-107.70	55.63	2.74	1.12	32	1	87.4	
CAN01203	-129.20	27	-111.48	55.61	3.08	1.15	151	1	87.4	9/GR12
CAN01303	-129.20	27	-102.42	57.12	3.54	0.91	154	1	87.4	9/GR12
CAN01304	-91.20	27	-99.12	57.36	1.98	1.72	2	1	87.4	9/GR13
CAN01403	-129.20	27	-89.75	52.02	4.68	0.78	148	1	87.4	9/GR12
CAN01404	-91.20	27	-84.82	52.42	3.10	2.05	152	1	87.4	9/GR13
CAN01405	-82.20	27	-84.00	52.39	2.84	2.29	172	1	87.4	9/GR14
CAN01504	-91.20	27	-72.66	53.77	3.57	1.67	156	1	87.4	9/GR13
CAN01505	-82.20	27	-71.77	53.79	3.30	1.89	162	1	87.4	9/GR14
CAN01605	-82.20	27	-61.50	49.55	2.65	1.40	143	1	87.4	9/GR14
CAN01606	-70.70	27	-61.30	49.55	2.40	1.65	148	1	87.4	
CHLCONT5	-106.20	27	-72.23	-35.57	2.60	0.68	55	1	87.4	9/GR17
CHLPAC02	-106.20	27	-80.06	-30.06	1.36	0.68	69	1	87.4	9/GR17
CLMAND01	-115.20	27	-71.37	-4.69	6.49	2.57	87	1	87.4	9/GR5
CLM00001	-103.20	27	-74.50	5.87	3.98	1.96	118	1	87.4	
CUB00001	-89.20	27	-79.81	21.62	2.24	0.68	168	1	87.4	
EQACAND1	-115.20	27	-71.37	-4.69	6.49	2.57	87	1	87.4	9/GR5
EQAGAND1	-115.20	27	-71.37	-4.69	6.49	2.57	87	1	87.4	9/GR5
GRD00059	-57.20	27	-61.58	12.29	0.60	0.60	90	1	87.4	
GRLDNK01	-53.20	27	-44.89	66.56	2.70	0.82	173	1	87.4	2
GUY00201	-84.70	27	-59.19	4.78	1.44	0.85	95	1	87.4	
HWA00002	-166.20	27	-165.79	23.42	4.20	0.68	160	1	87.4	9/GR1
HWA00003	-175.20	27	-166.10	23.42	4.25	0.68	159	1	87.4	9/GR2
MEX01NTE	-78.20	27	-105.81	26.01	2.89	2.08	155	1	87.4	1
MEX01SUR	-69.20	27	-94.84	19.82	3.05	2.09	4	1	87.4	1
MEX02NTE	-136.20	27	-107.21	26.31	3.84	1.55	148	1	87.4	1
MEX02SUR	-127.20	27	-96.39	19.88	3.18	1.87	157	1	87.4	1
MSR00001	-79.70	27	-61.73	16.75	0.60	0.60	90	1	87.4	4
PAQPAC01	-106.20	27	-109.18	-27.53	0.60	0.60	90	1	87.4	9/GR17
PRG00002	-99.20	27	-58.66	-23.32	1.45	1.04	76	1	87.4	
PRUAND02	-115.20	27	-71.37	-4.69	6.49	2.57	87	1	87.4	9/GR5
PTRVIR01	-101.20	27	-93.94	36.32	8.24	3.56	171	1	87.4	1 6 9/GR20
PTRVIR02	-110.20	27	-95.23	36.29	8.27	3.37	168	1	87.4	1 6 9/GR21
URG00001	-71.70	27	-56.22	-32.52	1.02	0.89	11	1	87.4	
USAEH001	-61.70	27	-87.57	36.17	6.42	3.49	12	1	87.4	1 5 6
USAEH002	-101.20	27	-93.94	36.32	8.24	3.56	171	1	87.4	1 6 9/GR20
USAEH003	-110.20	27	-95.23	36.29	8.27	3.37	168	1	87.4	1 6 9/GR21
USAEH004	-119.20	27	-96.45	36.21	8.20	3.12	165	1	87.4	1 5 6
USAPSA02	-166.20	27	-109.94	36.86	6.04	1.11	137	1	87.4	9/GR1
USAPSA03	-175.20	27	-116.23	37.50	5.60	0.75	132	1	87.4	9/GR2
USAWH01	-148.20	27	-111.02	40.68	4.36	2.15	162	1	87.4	
USAWH02	-157.20	27	-113.07	40.74	3.72	1.78	149	1	87.4	
VENAND03	-115.20	27	-71.37	-4.69	6.49	2.57	87	1	87.4	9/GR5

17 717.66 MHz (28)

1	2	3	4	5	6	7	8	9		
ALS00002	-165.80	28	-109.83	36.82	6.03	1.12	137	2	87.4	9/GR1
ALS00003	-174.80	28	-116.10	37.47	5.60	0.76	132	2	87.4	9/GR2
ARGNORT4	-93.80	28	-63.96	-30.01	3.86	1.99	48	2	87.4	
ARGNORT5	-54.80	28	-62.85	-29.80	3.24	2.89	47	2	87.4	
B CE311	-63.80	28	-40.60	-6.07	3.04	2.06	174	2	87.4	8 9/GR7
B CE312	-44.80	28	-40.26	-6.06	3.44	2.09	174	2	87.4	8 9/GR9
B CE411	-63.80	28	-50.97	-15.26	3.86	1.38	49	2	87.4	8 9/GR7
B CE412	-44.80	28	-50.71	-15.30	3.57	1.56	52	2	87.4	8 9/GR9
B CE511	-63.80	28	-53.11	-2.98	2.42	2.15	107	2	87.4	8 9/GR7
B NO611	-73.80	28	-59.60	-11.62	2.86	1.69	165	1	87.4	8 9/GR8
B NO711	-73.80	28	-60.70	-1.78	3.54	1.78	126	1	87.4	8 9/GR8
B NO811	-73.80	28	-68.75	-4.71	2.37	1.65	73	1	87.4	8 9/GR8
B SE911	-101.80	28	-45.99	-19.09	2.22	0.79	62	2	87.4	8
B SU111	-80.80	28	-51.10	-25.64	2.76	1.06	50	2	87.4	8 9/GR6
B SU112	-44.80	28	-50.76	-25.62	2.47	1.48	56	2	87.4	8 9/GR9
B SU211	-80.80	28	-44.51	-16.94	3.22	1.37	60	2	87.4	8 9/GR6
B SU212	-44.80	28	-43.99	-16.97	3.27	1.92	59	2	87.4	8 9/GR9
CAN01101	-137.80	28	-125.60	57.24	3.45	1.27	157	2	87.4	9/GR10
CAN01201	-137.80	28	-111.92	55.89	3.33	0.98	151	2	87.4	9/GR10
CAN01202	-72.30	28	-107.64	55.62	2.75	1.11	32	2	87.4	
CAN01203	-128.80	28	-111.43	55.56	3.07	1.15	151	2	87.4	9/GR12
CAN01303	-128.80	28	-102.39	57.12	3.54	0.92	154	2	87.4	9/GR12
CAN01304	-90.80	28	-99.00	57.33	1.96	1.73	1	2	87.4	9/GR13
CAN01403	-128.80	28	-89.70	52.02	4.67	0.79	148	2	87.4	9/GR12
CAN01404	-90.80	28	-84.78	52.41	3.09	2.06	153	2	87.4	9/GR13
CAN01405	-81.80	28	-84.02	52.34	2.82	2.30	172	2	87.4	9/GR13
CAN01504	-90.80	28	-72.68	53.78	3.57	1.67	157	2	87.4	9/GR13
CAN01505	-81.80	28	-71.76	53.76	3.30	1.89	162	2	87.4	9/GR14
CAN01605	-81.80	28	-61.54	49.50	2.66	1.39	144	2	87.4	9/GR14
CAN01606	-70.30	28	-61.32	49.51	2.41	1.65	148	2	87.4	
CHLCONT4	-105.80	28	-69.59	-23.20	2.21	0.69	68	2	87.4	9/GR16
CHLCONT6	-105.80	28	-73.52	-55.52	3.65	1.31	39	2	87.4	9/GR16
CRBBAH01	-92.30	28	-76.09	24.13	1.83	0.68	141	1	87.4	9/GR18
CRBBER01	-92.30	28	-64.76	32.13	0.60	0.60	90	1	87.4	9/GR18
CRBBLZ01	-92.30	28	-88.61	17.26	0.64	0.64	90	1	87.4	9/GR18
CRBEC001	-92.30	28	-60.07	8.26	4.20	0.86	115	1	87.4	9/GR18
CRBJMC01	-92.30	28	-79.45	17.97	0.99	0.68	151	1	87.4	9/GR18
EQAC0001	-94.80	28	-78.31	-1.52	1.48	1.15	65	1	87.4	9/GR19
EQAG0001	-94.80	28	-90.36	-0.57	0.94	0.89	99	1	87.4	9/GR19
GRD00003	-79.30	28	-61.62	12.34	0.60	0.60	90	2	87.4	
GTMIFRB2	-107.30	28	-90.50	15.64	1.03	0.74	84	1	87.4	
GUFMGG02	-52.80	28	-56.42	8.47	4.16	0.81	123	2	87.4	2 7
HWA00002	-165.80	28	-165.79	23.32	4.20	0.68	160	2	87.4	9/GR1
HWA00003	-174.80	28	-166.10	23.42	4.25	0.68	159	2	87.4	9/GR2
MEX01NTE	-77.80	28	-105.80	25.99	2.88	2.07	155	2	87.4	1
MEX02NTE	-135.80	28	-107.36	26.32	3.80	1.57	149	2	87.4	1
MEX02SUR	-126.80	28	-96.39	19.88	3.19	1.87	158	2	87.4	1
PNRIFRB2	-121.00	28	-80.15	8.46	1.01	0.73	170	1	87.4	
PRU00004	-85.80	28	-74.19	-8.39	3.74	2.45	112	2	87.4	
PTRVIR01	-100.80	28	-93.85	36.31	8.26	3.55	171	2	87.4	1 6 9/GR20
PTRVIR02	-109.80	28	-95.47	36.38	8.10	3.45	168	2	87.4	1 6 9/GR21
USAEH001	-61.30	28	-87.53	36.18	6.41	3.49	12	2	87.4	1 5 6
USAEH002	-100.80	28	-93.85	36.31	8.26	3.55	171	2	87.4	1 6 9/GR20
USAEH003	-109.80	28	-95.47	36.38	8.10	3.45	168	2	87.4	1 6 9/GR21
USAEH004	-118.80	28	-96.42	36.21	8.20	3.12	165	2	87.4	1 5 6
USAPSA02	-165.80	28	-109.83	36.82	6.03	1.12	137	2	87.4	9/GR1
USAPSA03	-174.80	28	-116.10	37.47	5.60	0.76	132	2	87.4	9/GR2
USAWH101	-147.80	28	-111.01	40.67	4.38	2.15	162	2	87.4	
USAWH102	-156.80	28	-113.01	40.71	3.74	1.79	149	2	87.4	
VEN02VEN	-103.80	28	-66.79	6.90	2.50	1.77	122	2	87.4	9/GR22
VEN11VEN	-103.80	28	-66.79	6.90	2.50	1.77	122	2	87.4	9/GR22

1	2	3	4	5	6	7	8	9		
ALS00002	-166.20	29	-109.94	36.86	6.04	1.11	137	1	87.4	9/GR1
ALS00003	-175.20	29	-116.23	37.50	5.60	0.75	132	1	87.4	9/GR2
ARGINSU4	-94.20	29	-52.98	-59.81	3.40	0.68	19	1	87.4	9/GR3
ARGINSU5	-55.20	29	-44.17	-59.91	3.77	0.70	13	1	87.4	9/GR4
ARGSUR04	-94.20	29	-65.04	-43.33	3.32	1.50	40	1	87.4	9/GR3
ARGSUR05	-55.20	29	-63.68	-43.01	2.54	2.38	152	1	87.4	9/GR4
B CE311	-64.20	29	-40.60	-6.07	3.04	2.06	174	1	87.4	8 9/GR7
B CE312	-45.20	29	-40.27	-6.06	3.44	2.09	174	1	87.4	8 9/GR9
B CE411	-64.20	29	-50.97	-15.27	3.86	1.38	49	1	87.4	8 9/GR7
B CE412	-45.20	29	-50.71	-15.30	3.57	1.56	52	1	87.4	8 9/GR9
B CE511	-64.20	29	-53.10	-2.90	2.44	2.13	104	1	87.4	8 9/GR7
B NO611	-74.20	29	-59.60	-11.62	2.85	1.69	165	2	87.4	8 9/GR8
B NO711	-74.20	29	-60.70	-1.78	3.54	1.78	126	2	87.4	8 9/GR8
B NO811	-74.20	29	-68.76	-4.71	2.37	1.65	73	2	87.4	8 9/GR8
B SU111	-81.20	29	-51.12	-25.63	2.76	1.05	50	1	87.4	8 9/GR6
B SU112	-45.20	29	-50.75	-25.62	2.47	1.48	56	1	87.4	8 9/GR9
B SU211	-81.20	29	-44.51	-16.95	3.22	1.36	60	1	87.4	8 9/GR6
B SU212	-45.20	29	-44.00	-16.87	3.20	1.96	58	1	87.4	8 9/GR9
BERBERMU	-96.20	29	-64.77	32.32	0.60	0.60	90	2	87.4	
BOLAND01	-115.20	29	-71.37	-4.69	6.49	2.57	87	1	87.4	9/GR5
CAN01101	-138.20	29	-125.63	57.24	3.45	1.27	157	1	87.4	9/GR10
CAN01201	-138.20	29	-112.04	55.95	3.35	0.97	151	1	87.4	9/GR10
CAN01202	-72.70	29	-107.70	55.63	2.74	1.12	32	1	87.4	
CAN01203	-129.20	29	-111.48	55.61	3.08	1.15	151	1	87.4	9/GR12
CAN01303	-129.20	29	-102.42	57.12	3.54	0.91	154	1	87.4	9/GR12
CAN01304	-91.20	29	-99.12	57.36	1.98	1.72	2	1	87.4	9/GR13
CAN01403	-129.20	29	-89.75	52.02	4.68	0.78	148	1	87.4	9/GR12
CAN01404	-91.20	29	-84.82	52.42	3.10	2.05	152	1	87.4	9/GR13
CAN01405	-82.20	29	-84.00	52.39	2.84	2.29	172	1	87.4	9/GR14
CAN01504	-91.20	29	-72.66	53.77	3.57	1.67	156	1	87.4	9/GR13
CAN01505	-82.20	29	-71.77	53.79	3.30	1.89	162	1	87.4	9/GR14
CAN01605	-82.20	29	-61.50	49.55	2.65	1.40	143	1	87.4	9/GR14
CAN01606	-70.70	29	-61.30	49.55	2.40	1.65	148	1	87.4	
CHLCONT5	-106.20	29	-72.23	-35.57	2.60	0.68	55	1	87.4	9/GR17
CHLPAC02	-106.20	29	-80.06	-30.06	1.36	0.68	69	1	87.4	9/GR17
CLMAND01	-115.20	29	-71.37	-4.69	6.49	2.57	87	1	87.4	9/GR5
CLM00001	-103.20	29	-74.50	5.87	3.98	1.96	118	1	87.4	
EQACAND1	-115.20	29	-71.37	-4.69	6.49	2.57	87	1	87.4	9/GR5
EQAGAND1	-115.20	29	-71.37	-4.69	6.49	2.57	87	1	87.4	9/GR5
HWA00002	-166.20	29	-165.79	23.42	4.20	0.68	160	1	87.4	9/GR1
HWA00003	-175.20	29	-166.10	23.42	4.25	0.68	159	1	87.4	9/GR2
JMC00002	-92.70	29	-77.30	18.12	0.62	0.62	90	2	87.4	
KNA00001	-79.70	29	-62.46	17.44	0.60	0.60	90	1	87.4	
MEX01NTE	-78.20	29	-105.81	26.01	2.89	2.08	155	1	87.4	1
MEX01SUR	-69.20	29	-94.84	19.82	3.05	2.09	4	1	87.4	1
MEX02NTE	-136.20	29	-107.21	26.31	3.84	1.55	148	1	87.4	1
MEX02SUR	-127.20	29	-96.39	19.88	3.18	1.87	157	1	87.4	1
PAQPAC01	-106.20	29	-109.18	-27.53	0.60	0.60	90	1	87.4	9/GR17
PRG00002	-99.20	29	-58.66	-23.32	1.45	1.04	76	1	87.4	
PRUAND02	-115.20	29	-71.37	-4.69	6.49	2.57	87	1	87.4	9/GR5
PTRVIR01	-101.20	29	-93.94	36.32	8.24	3.56	171	1	87.4	1 6 9/GR20
PTRVIR02	-110.20	29	-95.23	36.29	8.27	3.37	168	1	87.4	1 6 9/GR21
SPMFRAN3	-53.20	29	-67.24	47.51	3.16	0.79	7	1	87.4	2 7
SURINAM2	-84.70	29	-55.69	4.35	1.00	0.69	86	1	87.4	
URG00001	-71.70	29	-56.22	-32.52	1.02	0.89	11	1	87.4	
USAEH001	-61.70	29	-87.57	36.17	6.42	3.49	12	1	87.4	1 5 6
USAEH002	-101.20	29	-93.94	36.32	8.24	3.56	171	1	87.4	1 6 9/GR20
USAEH003	-110.20	29	-95.23	36.29	8.27	3.37	168	1	87.4	1 6 9/GR21
USAEH004	-119.20	29	-96.45	36.21	8.20	3.12	165	1	87.4	1 5 6
USAPSA02	-166.20	29	-109.94	36.86	6.04	1.11	137	1	87.4	9/GR1
USAPSA03	-175.20	29	-116.23	37.50	5.60	0.75	132	1	87.4	9/GR2
USAWH101	-148.20	29	-111.02	40.68	4.36	2.15	162	1	87.4	
USAWH102	-157.20	29	-113.07	40.74	3.72	1.78	149	1	87.4	
VENAND03	-115.20	29	-71.37	-4.69	6.49	2.57	87	1	87.4	9/GR5

17 746.82 MHz (30)

1	2	3	4		5		6	7	8	9
ALS00002	-165.80	30	-109.83	36.82	6.03	1.12	137	2	87.4	9/GR1
ALS00003	-174.80	30	-116.10	37.47	5.60	0.76	132	2	87.4	9/GR2
ARGNORT4	-93.80	30	-63.96	-30.01	3.86	1.99	48	2	87.4	
ARGNORT5	-54.80	30	-62.85	-29.80	3.24	2.89	47	2	87.4	
ATNBTEAM1	-52.80	30	-66.44	14.87	1.83	0.68	39	2	87.4	
B CE311	-63.80	30	-40.60	-6.07	3.04	2.06	174	2	87.4	8 9/GR7
B CE312	-44.80	30	-40.26	-6.06	3.44	2.09	174	2	87.4	8 9/GR9
B CE411	-63.80	30	-50.97	-15.26	3.86	1.38	49	2	87.4	8 9/GR7
B CE412	-44.80	30	-50.71	-15.30	3.57	1.56	52	2	87.4	8 9/GR9
B CE511	-63.80	30	-53.11	-2.98	2.42	2.15	107	2	87.4	8 9/GR7
B NO611	-73.80	30	-59.60	-11.62	2.86	1.69	165	1	87.4	8 9/GR8
B NO711	-73.80	30	-60.70	-1.78	3.54	1.78	126	1	87.4	8 9/GR8
B NO811	-73.80	30	-68.75	-4.71	2.37	1.65	73	1	87.4	8 9/GR8
B SE911	-101.80	30	-45.99	-19.09	2.22	0.79	62	2	87.4	8
B SU111	-80.80	30	-51.10	-25.64	2.76	1.06	50	2	87.4	8 9/GR6
B SU112	-44.80	30	-50.76	-25.62	2.47	1.48	56	2	87.4	8 9/GR9
B SU211	-80.80	30	-44.51	-16.94	3.22	1.37	60	2	87.4	8 9/GR6
B SU212	-44.80	30	-43.99	-16.97	3.27	1.92	59	2	87.4	8 9/GR9
BLZ00001	-115.80	30	-88.68	17.27	0.62	0.62	90	2	87.4	
CAN01101	-137.80	30	-125.60	57.24	3.45	1.27	157	2	87.4	9/GR10
CAN01201	-137.80	30	-111.92	55.89	3.33	0.98	151	2	87.4	9/GR10
CAN01202	-72.30	30	-107.64	55.62	2.75	1.11	32	2	87.4	
CAN01203	-128.80	30	-111.43	55.56	3.07	1.15	151	2	87.4	9/GR12
CAN01303	-128.80	30	-102.39	57.12	3.54	0.92	154	2	87.4	9/GR12
CAN01304	-90.80	30	-99.00	57.33	1.96	1.73	1	2	87.4	9/GR13
CAN01403	-128.80	30	-89.70	52.02	4.67	0.79	148	2	87.4	9/GR12
CAN01404	-90.80	30	-84.78	52.41	3.09	2.06	153	2	87.4	9/GR13
CAN01405	-81.80	30	-84.02	52.34	2.82	2.30	172	2	87.4	9/GR14
CAN01504	-90.80	30	-72.68	53.78	3.57	1.67	157	2	87.4	9/GR13
CAN01505	-81.80	30	-71.76	53.76	3.30	1.89	162	2	87.4	9/GR14
CAN01605	-81.80	30	-61.54	49.50	2.66	1.39	144	2	87.4	9/GR14
CAN01606	-70.30	30	-61.32	49.51	2.41	1.65	148	2	87.4	
CHLCONT4	-105.80	30	-69.59	-23.20	2.21	0.69	68	2	87.4	9/GR16
CHLCONT6	-105.80	30	-73.52	-55.52	3.65	1.31	39	2	87.4	9/GR16
CRBBAH01	-92.30	30	-76.09	24.13	1.83	0.68	141	1	87.4	9/GR18
CRBBER01	-92.30	30	-64.76	32.13	0.60	0.60	90	1	87.4	9/GR18
CRBBLZ01	-92.30	30	-88.61	17.26	0.64	0.64	90	1	87.4	9/GR18
CRBEC001	-92.30	30	-60.07	8.26	4.20	0.86	115	1	87.4	9/GR18
CRBJMC01	-92.30	30	-79.45	17.97	0.99	0.68	151	1	87.4	9/GR18
CTR00201	-130.80	30	-84.33	9.67	0.82	0.68	119	2	87.4	
DMAIFRB1	-79.30	30	-61.30	15.35	0.60	0.60	90	2	87.4	
EQAC0001	-94.80	30	-78.31	-1.52	1.48	1.15	65	1	87.4	9/GR19
EQAG0001	-94.80	30	-90.36	-0.57	0.94	0.89	99	1	87.4	9/GR19
HWAA0002	-165.80	30	-165.79	23.32	4.20	0.68	160	2	87.4	9/GR1
HWAA0003	-174.80	30	-166.10	23.42	4.25	0.68	159	2	87.4	9/GR2
MEX01NTE	-77.80	30	-105.80	25.99	2.88	2.07	155	2	87.4	1
MEX02NTE	-135.80	30	-107.36	26.32	3.80	1.57	149	2	87.4	1
MEX02SUR	-126.80	30	-96.39	19.88	3.19	1.87	158	2	87.4	1
NGCG0003	-107.30	30	-84.99	12.90	1.05	1.01	176	1	87.4	
PRU00004	-85.80	30	-74.19	-8.39	3.74	2.45	112	2	87.4	
PTRVIR01	-100.80	30	-93.85	36.31	8.26	3.55	171	2	87.4	1 6 9/GR20
PTRVIR02	-109.80	30	-95.47	36.38	8.10	3.45	168	2	87.4	1 6 9/GR21
USAEH001	-61.30	30	-87.53	36.18	6.41	3.49	12	2	87.4	1 5 6
USAEH002	-100.80	30	-93.85	36.31	8.26	3.55	171	2	87.4	1 6 9/GR20
USAEH003	-109.80	30	-95.47	36.38	8.10	3.45	168	2	87.4	1 6 9/GR21
USAEH004	-118.80	30	-96.42	36.21	8.20	3.12	165	2	87.4	1 5 6
USAPSA02	-165.80	30	-109.83	36.82	6.03	1.12	137	2	87.4	9/GR1
USAPSA03	-174.80	30	-116.10	37.47	5.60	0.76	132	2	87.4	9/GR2
USAWH01	-147.80	30	-111.01	40.67	4.38	2.15	162	2	87.4	
USAWH02	-156.80	30	-113.01	40.71	3.74	1.79	149	2	87.4	
VEN11VEN	-103.80	30	-66.79	6.90	2.50	1.77	122	2	87.4	

1	2	3	4		5		6	7	8	9
ALS00002	-166.20	31	-109.94	36.86	6.04	1.11	137	1	87.4	9/GR1
ALS00003	-175.20	31	-116.23	37.50	5.60	0.75	132	1	87.4	9/GR2
ARGINSU4	-94.20	31	-52.98	-59.81	3.40	0.68	19	1	87.4	9/GR3
ARGINSU5	-55.20	31	-44.17	-59.91	3.77	0.70	13	1	87.4	9/GR4
ARGSUR04	-94.20	31	-65.04	-43.33	3.32	1.50	40	1	87.4	9/GR3
ARGSUR05	-55.20	31	-63.68	-43.01	2.54	2.38	152	1	87.4	9/GR4
B CE311	-64.20	31	-40.60	-6.07	3.04	2.06	174	1	87.4	8 9/GR7
B CE312	-45.20	31	-40.27	-6.06	3.44	2.09	174	1	87.4	8 9/GR9
B CE411	-64.20	31	-50.97	-15.27	3.86	1.38	49	1	87.4	8 9/GR7
B CE412	-45.20	31	-50.71	-15.30	3.57	1.56	52	1	87.4	8 9/GR9
B CE511	-64.20	31	-53.10	-2.90	2.44	2.13	104	1	87.4	8 9/GR7
B NO611	-74.20	31	-59.60	-11.62	2.85	1.69	165	2	87.4	8 9/GR8
B NO711	-74.20	31	-60.70	-1.78	3.54	1.78	126	2	87.4	8 9/GR8
B NO811	-74.20	31	-68.76	-4.71	2.37	1.65	73	2	87.4	8 9/GR8
B SU111	-81.20	31	-51.12	-25.63	2.76	1.05	50	1	87.4	8 9/GR6
B SU112	-45.20	31	-50.75	-25.62	2.47	1.48	56	1	87.4	8 9/GR9
B SU211	-81.20	31	-44.51	-16.95	3.22	1.36	60	1	87.4	8 9/GR6
B SU212	-45.20	31	-44.00	-16.87	3.20	1.96	58	1	87.4	8 9/GR9
BERBERMU	-96.20	31	-64.77	32.32	0.60	0.60	90	2	87.4	
BOLAND01	-115.20	31	-71.37	-4.69	6.49	2.57	87	1	87.4	9/GR5
BOL00001	-87.20	31	-64.61	-16.71	2.52	2.19	85	1	87.4	
BRB00001	-92.70	31	-59.85	12.93	0.60	0.60	90	2	87.4	
CAN01101	-138.20	31	-125.63	57.24	3.45	1.27	157	1	87.4	9/GR10
CAN01201	-138.20	31	-112.04	55.95	3.35	0.97	151	1	87.4	9/GR10
CAN01202	-72.70	31	-107.70	55.63	2.74	1.12	32	1	87.4	
CAN01203	-129.20	31	-111.48	55.61	3.08	1.15	151	1	87.4	9/GR12
CAN01303	-129.20	31	-102.42	57.12	3.54	0.91	154	1	87.4	9/GR12
CAN01304	-91.20	31	-99.12	57.36	1.98	1.72	2	1	87.4	9/GR13
CAN01403	-129.20	31	-89.75	52.02	4.68	0.78	148	1	87.4	9/GR12
CAN01404	-91.20	31	-84.82	52.42	3.10	2.05	152	1	87.4	9/GR13
CAN01405	-82.20	31	-84.00	52.39	2.84	2.29	172	1	87.4	9/GR14
CAN01504	-91.20	31	-72.66	53.77	3.57	1.67	156	1	87.4	9/GR13
CAN01505	-82.20	31	-71.77	53.79	3.30	1.89	162	1	87.4	9/GR14
CAN01605	-82.20	31	-61.50	49.55	2.65	1.40	143	1	87.4	9/GR14
CAN01606	-70.70	31	-61.30	49.55	2.40	1.65	148	1	87.4	
CHLCONT5	-106.20	31	-72.23	-35.57	2.60	0.68	55	1	87.4	9/GR17
CHLPAC02	-106.20	31	-80.06	-30.06	1.36	0.68	69	1	87.4	9/GR17
CLMAND01	-115.20	31	-71.37	-4.69	6.49	2.57	87	1	87.4	9/GR5
CLM00001	-103.20	31	-74.50	5.87	3.98	1.96	118	1	87.4	
CUB00001	-89.20	31	-79.81	21.62	2.24	0.68	168	1	87.4	
EQACAND1	-115.20	31	-71.37	-4.69	6.49	2.57	87	1	87.4	9/GR5
EQAGAND1	-115.20	31	-71.37	-4.69	6.49	2.57	87	1	87.4	9/GR5
GRD00059	-57.20	31	-61.58	12.29	0.60	0.60	90	1	87.4	
GRLDNK01	-53.20	31	-44.89	66.56	2.70	0.82	173	1	87.4	2
GUY00201	-84.70	31	-59.19	4.78	1.44	0.85	95	1	87.4	
HWA00002	-166.20	31	-165.79	23.42	4.20	0.68	160	1	87.4	9/GR1
HWA00003	-175.20	31	-166.10	23.42	4.25	0.68	159	1	87.4	9/GR2
MEX01NTE	-78.20	31	-105.81	26.01	2.89	2.08	155	1	87.4	1
MEX01SUR	-69.20	31	-94.84	19.82	3.05	2.09	4	1	87.4	1
MEX02NTE	-136.20	31	-107.21	26.31	3.84	1.55	148	1	87.4	1
MEX02SUR	-127.20	31	-96.39	19.88	3.18	1.87	157	1	87.4	1
MSR00001	-79.70	31	-61.73	16.75	0.60	0.60	90	1	87.4	4
PAQPAC01	-106.20	31	-109.18	-27.53	0.60	0.60	90	1	87.4	9/GR17
PRG00002	-99.20	31	-58.66	-23.32	1.45	1.04	76	1	87.4	
PRUAND02	-115.20	31	-71.37	-4.69	6.49	2.57	87	1	87.4	9/GR5
PTRVIR01	-101.20	31	-93.94	36.32	8.24	3.56	171	1	87.4	1 6 9/GR20
PTRVIR02	-110.20	31	-95.23	36.29	8.27	3.37	168	1	87.4	1 6 9/GR21
URG00001	-71.70	31	-56.22	-32.52	1.02	0.89	11	1	87.4	
USAEH001	-61.70	31	-87.57	36.17	6.42	3.49	12	1	87.4	1 5 6
USAEH002	-101.20	31	-93.94	36.32	8.24	3.56	171	1	87.4	1 6 9/GR20
USAEH003	-110.20	31	-95.23	36.29	8.27	3.37	168	1	87.4	1 6 9/GR21
USAEH004	-119.20	31	-96.45	36.21	8.20	3.12	165	1	87.4	1 5 6
USAPSA02	-166.20	31	-109.94	36.86	6.04	1.11	137	1	87.4	9/GR1
USAPSA03	-175.20	31	-116.23	37.50	5.60	0.75	132	1	87.4	9/GR2
USAWH01	-148.20	31	-111.02	40.68	4.36	2.15	162	1	87.4	
USAWH02	-157.20	31	-113.07	40.74	3.72	1.78	149	1	87.4	
VENAND03	-115.20	31	-71.37	-4.69	6.49	2.57	87	1	87.4	9/GR5

17 775.98 MHz (32)

1	2	3	4	5	6	7	8	9		
ALS00002	-165.80	32	-109.83	36.82	6.03	1.12	137	2	87.4	9/GR1
ALS00003	-174.80	32	-116.10	37.47	5.60	0.76	132	2	87.4	9/GR2
ARGNORT4	-93.80	32	-63.96	-30.01	3.86	1.99	48	2	87.4	
ARGNORT5	-54.80	32	-62.85	-29.80	3.24	2.89	47	2	87.4	
B CE311	-63.80	32	-40.60	-6.07	3.04	2.06	174	2	87.4	8 9/GR7
B CE312	-44.80	32	-40.26	-6.06	3.44	2.09	174	2	87.4	8 9/GR9
B CE411	-63.80	32	-50.97	-15.26	3.86	1.38	49	2	87.4	8 9/GR7
B CE412	-44.80	32	-50.71	-15.30	3.57	1.56	52	2	87.4	8 9/GR9
B CE511	-63.80	32	-53.11	-2.98	2.42	2.15	107	2	87.4	8 9/GR7
B NO611	-73.80	32	-59.60	-11.62	2.86	1.69	165	1	87.4	8 9/GR8
B NO711	-73.80	32	-60.70	-1.78	3.54	1.78	126	1	87.4	8 9/GR8
B NOR11	-73.80	32	-68.75	-4.71	2.37	1.65	73	1	87.4	8 9/GR8
B SE911	-101.80	32	-45.99	-19.09	2.22	0.79	62	2	87.4	8
B SU111	-80.80	32	-51.10	-25.64	2.76	1.06	50	2	87.4	8 9/GR6
B SU112	-44.80	32	-50.76	-25.62	2.47	1.48	56	2	87.4	8 9/GR9
B SU211	-80.80	32	-44.51	-16.94	3.22	1.37	60	2	87.4	8 9/GR6
B SU212	-44.80	32	-43.99	-16.97	3.27	1.92	59	2	87.4	8 9/GR9
CAN01101	-137.80	32	-125.60	57.24	3.45	1.27	157	2	87.4	9/GR10
CAN01201	-137.80	32	-111.92	55.89	3.33	0.98	151	2	87.4	9/GR10
CAN01202	-72.30	32	-107.64	55.62	2.75	1.11	32	2	87.4	
CAN01203	-128.80	32	-111.43	55.56	3.07	1.15	151	2	87.4	9/GR12
CAN01303	-128.80	32	-102.39	57.12	3.54	0.92	154	2	87.4	9/GR12
CAN01304	-90.80	32	-99.00	57.33	1.96	1.73	1	2	87.4	9/GR13
CAN01403	-128.80	32	-89.70	52.02	4.67	0.79	148	2	87.4	9/GR12
CAN01404	-90.80	32	-84.78	52.41	3.09	2.06	153	2	87.4	9/GR13
CAN01405	-81.80	32	-84.02	52.34	2.82	2.30	172	2	87.4	9/GR14
CAN01504	-90.80	32	-72.68	53.78	3.57	1.67	157	2	87.4	9/GR13
CAN01505	-81.80	32	-71.76	53.76	3.30	1.89	162	2	87.4	9/GR14
CAN01605	-81.80	32	-61.54	49.50	2.66	1.39	144	2	87.4	9/GR14
CAN01606	-70.30	32	-61.32	49.51	2.41	1.65	148	2	87.4	
CHLCONT4	-105.80	32	-69.59	-23.20	2.21	0.69	68	2	87.4	9/GR16
CHLCONT6	-105.80	32	-73.52	-55.52	3.65	1.31	39	2	87.4	9/GR16
CRBBAAH01	-92.30	32	-76.09	24.13	1.83	0.68	141	1	87.4	9/GR18
CRBBER01	-92.30	32	-64.76	32.13	0.60	0.60	90	1	87.4	9/GR18
CRBBBLZ01	-92.30	32	-88.61	17.26	0.64	0.64	90	1	87.4	9/GR18
CRBCEC001	-92.30	32	-60.07	8.26	4.20	0.86	115	1	87.4	9/GR18
CRBJMC01	-92.30	32	-79.45	17.97	0.99	0.68	151	1	87.4	9/GR18
EQAC0001	-94.80	32	-78.31	-1.52	1.48	1.15	65	1	87.4	9/GR19
EQAG0001	-94.80	32	-90.36	-0.57	0.94	0.89	99	1	87.4	9/GR19
GRD00003	-79.30	32	-61.62	12.34	0.60	0.60	90	2	87.4	
GTMIFRB2	-107.30	32	-90.50	15.64	1.03	0.74	84	1	87.4	
GUFMGG02	-52.80	32	-56.42	8.47	4.16	0.81	123	2	87.4	2 7
HWA00002	-165.80	32	-165.79	23.32	4.20	0.68	160	2	87.4	9/GR1
HWA00003	-174.80	32	-166.10	23.42	4.25	0.68	159	2	87.4	9/GR2
MEX01NTE	-77.80	32	-105.80	25.99	2.88	2.07	155	2	87.4	1
MEX02NTE	-135.80	32	-107.36	26.32	3.80	1.57	149	2	87.4	1
MEX02SUR	-126.80	32	-96.39	19.88	3.19	1.87	158	2	87.4	1
PNRIFRB2	-121.00	32	-80.15	8.46	1.01	0.73	170	1	87.4	
PRU00004	-85.80	32	-74.19	-8.39	3.74	2.45	112	2	87.4	
PTRVIR01	-100.80	32	-93.85	36.31	8.26	3.55	171	2	87.4	1 6 9/GR20
PTRVIR02	-109.80	32	-95.47	36.38	8.10	3.45	168	2	87.4	1 6 9/GR21
USAEH001	-61.30	32	-87.53	36.18	6.41	3.49	12	2	87.4	1 5 6
USAEH002	-100.80	32	-93.85	36.31	8.26	3.55	171	2	87.4	1 6 9/GR20
USAEH003	-109.80	32	-95.47	36.38	8.10	3.45	168	2	87.4	1 6 9/GR21
USAEH004	-118.80	32	-96.42	36.21	8.20	3.12	165	2	87.4	1 5 6
USAPSA02	-165.80	32	-109.83	36.82	6.03	1.12	137	2	87.4	9/GR1
USAPSA03	-174.80	32	-116.10	37.47	5.60	0.76	132	2	87.4	9/GR2
USAWH101	-147.80	32	-111.01	40.67	4.38	2.15	162	2	87.4	
USAWH102	-156.80	32	-113.01	40.71	3.74	1.79	149	2	87.4	
VEN02VEN	-103.80	32	-66.79	6.90	2.50	1.77	122	2	87.4	9/GR22
VEN11VEN	-103.80	32	-66.79	6.90	2.50	1.77	122	2	87.4	9/GR22



ARTICLE 9A (REV.WRC-19)

**Plan for feeder links for the broadcasting-satellite service in the fixed-satellite service in the frequency bands 14.5-14.8 GHz and 17.3-18.1 GHz in Regions 1 and 3**

9A.1 COLUMN HEADINGS OF THE PLAN

Col. 1 *Notifying administration symbol.*

Col. 2 *Beam identification* (Column 2, normally, contains the symbol designating the administration or the geographical area taken from Table B1 of the Preface to the International Frequency Information Circular (BR IFIC), followed by the symbol designating the service area).

Col. 3 *Nominal orbital position*, in degrees and hundredths of a degree from the Greenwich meridian (negative values indicate longitudes which are west of the Greenwich meridian; positive values indicate longitudes which are east of the Greenwich meridian).

Col. 4 *Nominal intersection of the beam axis with the Earth* (boresight or aim point in the case of a non-elliptical beam), longitude and latitude, in degrees and hundredths of a degree.

Col. 5 *Space station receiving antenna characteristics* (elliptical beams). This Column contains three numerical values corresponding to the major axis, the minor axis and the major axis orientation respectively of the elliptical cross-section half-power beam, in degrees and hundredths of a degree. Orientation of the ellipse determined as follows: in a plane normal to the beam axis, the direction of a major axis of the ellipse is specified as the angle measured anticlockwise from a line parallel to the equatorial plane to the major axis of the ellipse, to the nearest degree.

Col. 6 *Space station receiving antenna pattern code.*

The codes used for the antenna pattern of the receiving space station (feeder link) antenna are defined as follows:

R13RSS	Figure B (Curves A, B and C) and § 3.7.3 in Annex 3
R123FR	Figure C and § 3.7.3 in Annex 3
MODRSS	Figure B (Curves A', B' and C) and § 3.7.3 in Annex 3 (Recommendation ITU-R BO.1296)

In cases where the “Space station receiving antenna pattern code” field is blank, the necessary antenna pattern data are provided by shaped beam data submitted by the administration. These data are stored in Column 7. A particular shaped beam is identified by the combination of Column 1, Column 7 and Column 14. In such cases the maximum cross-polar gain is given in Column 8, Cross-polar gain field.

In cases where the “Space station receiving antenna pattern code” field contains a code which starts with “CB\_” characters, it is a composite beam. Any composite beam consists of two or more elliptical beams. Each composite beam is described in the special composite beam file having the same name plus a GXT extension (e.g. the description of the CB\_COMP\_BM1 composite beam is stored in the CB\_COMP\_BM1.GXT file).

- Col. 7 *Space station receiving antenna shaped (non-elliptical, non-composite) beam identification.*
- Col. 8 *Maximum space station receiving antenna co-polar and cross-polar (in the case of shaped beam) isotropic gain (dBi).*
- Col. 9 *Earth station transmitting antenna pattern code and maximum gain (dBi).*

The codes used for transmitting earth station (feeder-link) antenna patterns are defined as follows:

R13TES	Figure A (Curves A and B) and § 3.5.3 in Annex 3
MODTES	Figure A (Curves A' and B') and § 3.5.3 in Annex 3 (Recommendation ITU-R BO.1295)

- Col. 10 *Polarization (CL – circular left, CR – circular right, LE – linear referenced to the equatorial plane) and polarization angle in degrees and hundredths of a degree (in the case of linear polarization only).*
- Col. 11 *e.i.r.p.* in the direction of maximum radiation (dBW).
- Col. 12 *Permitted increase in earth station e.i.r.p.* (dB) for the purpose of power control (see § 3.11 of Annex 3). (WRC-15)
- Col. 13 *Designation of emission.*
- Col. 14 *Identity of the space station.*
- Col. 15 *Group code* (an identification code which indicates that all assignments with the same group identification code will be treated as a group).

Group code: if an assignment is part of the group:

- a) the equivalent protection margin to be used for the application of Article 4 shall be calculated on the following basis:
  - for the calculation of interference to assignments that are part of a group, only the interference contributions from assignments that are not part of the same group are to be included, *and*

---

<sup>32</sup> (SUP - WRC-15)

- for the calculation of interference from assignments belonging to a group to assignments that are not part of that same group, only the worst interference contribution from that group shall be used on a test point to test point basis.
- b) If an administration notifies the same frequency in more than one beam of a group for use at the same time, the aggregate *C/I* ratio produced by all emissions from that group shall not exceed the *C/I* ratio calculated on the basis of § a) above.

Col. 16 *Assignment status.*

The assignment status codes used for beams are defined as follows:

p	Assignment in the Regions 1 and 3 feeder-link Plan which has not been brought into use and/or the date of bringing into use has not been confirmed to the Bureau. For this category of assignments, WRC-2000 protection ratios are applied (27 dB co-channel and 22 dB adjacent channel).
PE	Assignment in the Regions 1 and 3 feeder-link Plan, which is in conformity with Appendix 30A, has been notified, brought into use and the date of bringing into use has been confirmed to the Bureau before 12 May 2000. For this category of assignments, WRC-97 protection ratios are applied (30 dB co-channel and 22 dB adjacent channel).

Col. 17 *Remarks.*

9A.2 TEXT FOR NOTES IN THE REMARKS COLUMN OF THE  
REGIONS 1 AND 3 FEEDER-LINK PLAN (WRC-19)

1 (Not used.)

2 (Not used.)

3 (Not used.)

4 (Not used.)

5 This assignment shall be brought into use only when the limits given in § 5 of Annex 1 are not exceeded, or with the agreement of the administrations identified in Table 1A, whose networks or beams listed in this Table may be affected with respect to assignments which are in conformity with the Region 2 feeder-link Plan on 12 May 2000 (see also Note to § 9A.2).

6 This assignment shall not claim protection from interference caused by the assignments which pertain to networks or beams identified in Table 1B which are in conformity with the Region 2 feeder-link Plan on 12 May 2000 (see also Note to § 9A.2).

7 This assignment shall not claim protection from interference caused by the assignments which pertain to networks or beams identified in Table 1B which are recorded in the Master Register with a favourable finding prior to 12 May 2000 (see also Note to § 9A.2).

The methodology and criteria for this analysis shall be those contained in § 1 of Annex 4, modified to take into consideration the system noise temperature of the received space station to be 600 K and to apply a  $\Delta T/T$  criterion of 6%.

8 Provisional beam. These assignments have been included in the Regions 1 and 3 feeder-link Plan by WRC-97. These assignments are for exclusive use by Palestine, subject to the Israeli-Palestinian Interim Agreement of 28 September 1995, Resolution 741 of the Council notwithstanding and Resolution 99 (Minneapolis, 1998) of the Plenipotentiary Conference.

9 (Not used.)

10 (SUP - WRC-12)

NOTE – In cases where assignments from the WRC-97 Plans without Remarks were included in the WRC-2000 Regions 1 and 3 feeder-link Plan without change, or with conversion of modulation from analogue to digital, or a change from normal roll-off to fast roll-off antenna characteristics, the coordination status afforded by the WRC-97 Plans shall be preserved.

In cases where assignments from the WRC-97 Plans with Remarks were included in the WRC-2000 Regions 1 and 3 feeder-link Plan without change, or with conversion of modulation from analogue to digital, or a change from normal roll-off to fast roll-off antenna pattern, the compatibility will be reassessed using the revised criteria and methodology of WRC-2000 and the Remarks of the WRC-97 Plans assignment will either be maintained or reduced on the basis of the results of this analysis.

In other cases, the methodology described in Notes 5 to 7 shall be applied.

TABLE 1A (WRC-07)  
**Affected administrations and corresponding networks/beams identified based on Note 5 in § 9A.2 of Article 9A**

Beam name	Channels	Affected administrations*	Affected networks/beams*
CPV30100	2, 4, 8, 10, 12	GUY JMC	GUY00302, JMC00005
CPV30100	6	JMC	JMC00005
G 02700	2, 4, 8, 10, 12	GUY JMC	GUY00302, JMC00005
G 02700	6	JMC	JMC00005
LBR24400	1	GUY	GUY00302
LBR24400	3, 9, 13	JMC	JMC00005
LBR24400	5, 7, 11	GUY JMC	GUY00302, JMC00005

\* Administrations and corresponding networks or beams whose assignment(s) may receive interference from the beam shown in the left-hand column.

TABLE 1B (WRC-15)  
**Affecting administrations and corresponding networks/beams identified based on Notes 6 and 7 in § 9A.2 of Article 9A**

Beam name	Channels	Note	Affecting administrations*	Affecting networks/beams*
CPV30100	2, 4, 8, 10, 12	6	GUY JMC	GUY00302, JMC00005
CPV30100	6	6	JMC	JMC00005
E 100	1, 3, 5, 7, 9, 11, 13	6	G	BERBER02
G 02700	2, 4, 8, 10, 12	6	GUY JMC	GUY00302, JMC00005
G 02700	6	6	JMC	JMC00005
LBR24400	1	6	GUY	GUY00302
LBR24400	3, 9, 13	6	JMC	JMC00005
LBR24400	5, 7, 11	6	GUY JMC	GUY00302, JMC00005

\* Administrations and corresponding networks or beams whose assignment(s) may cause interference to the beam shown in the left-hand column.

TABLE 2A

**Table showing correspondence between channel numbers and assigned frequencies<sup>1</sup> for the feeder links in the frequency band 14.5-14.8 GHz**

Channel No.	Assigned feeder-link frequency (MHz)
1	14 525.30
2	14 544.48
3	14 563.66
4	14 582.84
5	14 602.02
6	14 621.20
7	14 640.38
8	14 659.56
9	14 678.74
10	14 697.92
11	14 717.10
12	14 736.28
13	14 755.46
14	14 774.64

<sup>1</sup> Assigned frequency = 14 506.12 + 19.18  $n$ , where  $n$  is the channel number.

TABLE 2B

**Table showing correspondence between channel numbers and assigned frequencies<sup>1</sup> for the feeder links in the frequency band 17.3-18.1 GHz**

Channel No.	Assigned feeder-link frequency (MHz)	Channel No.	Assigned feeder-link frequency (MHz)
1	17 327.48	21	17 711.08
2	17 346.66	22	17 730.26
3	17 365.84	23	17 749.44
4	17 385.02	24	17 768.62
5	17 404.20	25	17 787.80
6	17 423.38	26	17 806.98
7	17 442.56	27	17 826.16
8	17 461.74	28	17 845.34
9	17 480.92	29	17 864.52
10	17 500.10	30	17 883.70
11	17 519.28	31	17 902.88
12	17 538.46	32	17 922.06
13	17 557.64	33	17 941.24
14	17 576.82	34	17 960.42
15	17 596.00	35	17 979.60
16	17 615.18	36	17 998.78
17	17 634.36	37	18 017.96
18	17 653.54	38	18 037.14
19	17 672.72	39	18 056.32
20	17 691.90	40	18 075.50

<sup>1</sup> Assigned frequency = 17 308.3 + 19.18  $n$ , where  $n$  is the channel number.

TABLE 3A1 (WRC-19)  
Basic characteristics of the Regions 1 and 3 feeder-link Plan in the frequency band 14.5-14.8 GHz (sorted by administration)

1	2	3	4		5			6		7	8		9	10		11	12	13	14	15	16	17
			Admin. symbol	Beam identification	Orbital position	Boresight	Major axis	Minor axis	Orientation		Space station antenna characteristics	Shaped beam		Co-polar	Cross-polar							
AFS	AFS02/01	4.80	24.50	-28.00	3.13	1.68	27.00	MODRSS	37.24			MODTES	57.00	CL	82.0			27W0G7W		4L	P	
AFS	AFS02/02	4.80	24.50	-28.00	3.13	1.68	27.00	MODRSS	37.24			MODTES	57.00	CR	82.0			27W0G7W		4L	P	
CHN	CHN19001	122.00	114.17	23.32	0.91	0.60	2.88	MODRSS	47.08			MODTES	57.00	CL	84.0			27W0G7W		4C	P	
CHN	CHN19002	122.00	114.17	23.32	0.91	0.60	2.88	MODRSS	47.08			MODTES	57.00	CR	84.0			27W0G7W		4C	P	
CNE	CNE30001	-13.00	12.70	6.20	2.54	1.68	87.00	MODRSS	38.15			MODTES	57.00	CL	84.0			27W0G7W		4I	P	
CNE	CNE30002	-13.00	12.70	6.20	2.54	1.68	87.00	MODRSS	38.15			MODTES	57.00	CR	84.0			27W0G7W		4I	P	
ETH	ETH02001	36.00	40.49	9.20	2.83	2.26	174.44	MODRSS	36.40			MODTES	57.00	CL	82.0			27W0G7W		4P	P	
ETH	ETH02002	36.00	40.49	9.20	2.83	2.26	174.44	MODRSS	36.40			MODTES	57.00	CR	82.0			27W0G7W		4P	P	
GHA	GHA10801	-25.00	-1.20	7.90	1.48	1.06	102.00	MODRSS	42.49			MODTES	57.00	CR	83.0			27W0G7W		4F	P	
GHA	GHA10802	-25.00	-1.20	7.90	1.48	1.06	102.00	MODRSS	42.49			MODTES	57.00	CL	83.0			27W0G7W		4F	P	
IND	INDA_101	55.80	76.16	14.72				CB_FSS_INDIA	45.66			MODTES	57.00	CR	82.0			27W0G7W		4U	P	
IND	INDA_102	55.80	76.16	14.72				CB_FSS_INDIA	45.66			MODTES	57.00	CL	82.0			27W0G7W		4U	P	
IRN	IRN19001	34.00	54.20	32.40	3.82	1.82	149.00	MODRSS	36.03			MODTES	57.00	CR	82.0			27W0G7W		4S	P	
IRN	IRN19002	34.00	54.20	32.40	3.82	1.82	149.00	MODRSS	36.03			MODTES	57.00	CL	82.0			27W0G7W		4S	P	
IRQ	IRQ25601	50.00	43.86	32.86	1.82	1.34	162.65	MODRSS	40.58			MODTES	57.00	CL	82.0			27W0G7W		4M	P	
IRQ	IRQ25602	50.00	43.86	32.86	1.82	1.34	162.65	MODRSS	40.58			MODTES	57.00	CR	82.0			27W0G7W		4M	P	
KOR	KOR1201D	116.00	127.50	36.00	1.24	1.02	168.00	R13RSS	43.40			R13TES	57.30	CL	82.0			27W0G7W	KOREASAT-1	03	PE	
KOR	KOR11201	116.00	127.50	36.00	1.24	1.02	168.00	R13RSS	43.40			R13TES	57.30	CL	82.0			27W0G7W	KOREASAT-1	03	PE	
MOZ	MOZ030701	-1.00	34.00	-18.00	3.57	1.38	55.00	MODRSS	37.52			MODTES	57.00	CL	82.0			27W0G7W		4K	P	
MOZ	MOZ030702	-1.00	34.00	-18.00	3.57	1.38	55.00	MODRSS	37.52			MODTES	57.00	CR	82.0			27W0G7W		4K	P	
NIG	NIG11901	-19.20	7.80	9.40	2.16	2.02	45.00	MODRSS	38.05			MODTES	57.00	CR	82.0			27W0G7W		4G	P	
NIG	NIG11902	-19.20	7.80	9.40	2.16	2.02	45.00	MODRSS	38.05			MODTES	57.00	CL	82.0			27W0G7W		4G	P	
NMB	NMB02501	-18.80	17.50	-21.60	2.66	1.90	48.00	MODRSS	37.41			MODTES	57.00	CL	82.0			27W0G7W		4H	P	
NMB	NMB02502	-18.80	17.50	-21.60	2.66	1.90	48.00	MODRSS	37.41			MODTES	57.00	CR	82.0			27W0G7W		4H	P	
NPL	NPL12201	50.00	83.70	28.30	1.72	0.60	163.00	MODRSS	44.31			MODTES	57.00	CR	82.0			27W0G7W		4N	P	

1	2	3	4		5			6		7	8		9		10		11	12	13	14	15	16	17
			Admin. symbol	Beam identification	Orbital position	Boresight		Space station antenna characteristics			Space station antenna code	Shaped beam	Space station antenna gain		Earth station antenna								
Long.	Lat.	Major axis				Minor axis	Orbit	Co-polar	Cross-polar	Code			Gain	Type	Angle	e.i.r.p.							
NPL	NPL1232	50.00	83.70	28.30	1.72	0.60	163.00	MODRSS			44.31	MODTES	57.00	CL	82.0		27M0G7W			4N	P		
PAK	PAK12701	38.20	69.60	29.50	2.30	2.16	14.00	MODRSS			37.49	MODTES	57.00	CR	82.0		27M0G7W			4R	P		
PAK	PAK12702	38.20	69.60	29.50	2.30	2.16	14.00	MODRSS			37.49	MODTES	57.00	CL	82.0		27M0G7W			4R	P		
PNG	PNG13101	134.00	148.07	-6.65	3.13	2.30	168.32	MODRSS			38.87	MODTES	57.00	CR	89.0		27M0G7W			4B	P		
PNG	PNG13102	134.00	148.07	-6.65	3.13	2.30	168.32	MODRSS			38.87	MODTES	57.00	CL	89.0		27M0G7W			4B	P		
SDN	SDN_101	-7.00	30.13	13.52				CB_FSS_SDNA			37.20	MODTES	57.00	CL	86.0		27M0G7W			4J	P		
SDN	SDN_102	-7.00	30.13	13.52				CB_FSS_SDNA			37.20	MODTES	57.00	CR	86.0		27M0G7W			4J	P		
SEN	SENZ2201	-37.00	-14.40	13.80	1.46	1.04	139.00	MODRSS			42.63	MODTES	57.00	CL	82.0		27M0G7W			4D	P		
SEN	SENZ2202	-37.00	-14.40	13.80	1.46	1.04	139.00	MODRSS			42.63	MODTES	57.00	CR	82.0		27M0G7W			4D	P		
SEY	SEY00001	42.50	51.86	-7.23	2.43	1.04	27.51	MODRSS			40.44	MODTES	57.00	CL	84.0		27M0G7W			4T	P		
SEY	SEY00002	42.50	51.86	-7.23	2.43	1.04	27.51	MODRSS			40.44	MODTES	57.00	CR	84.0		27M0G7W			4T	P		
SOM	SOM31201	37.80	45.17	6.61	3.37	1.68	62.04	MODRSS			36.92	MODTES	57.00	CL	83.0		27M0G7W			4Q	P		
SOM	SOM31202	37.80	45.17	6.61	3.37	1.68	62.04	MODRSS			36.92	MODTES	57.00	CR	83.0		27M0G7W			4Q	P		
TGO	TGOZ2601	-30.00	0.68	8.57	1.13	0.60	108.43	MODRSS			46.14	MODTES	57.00	CL	82.0		27M0G7W			4E	P		
TGO	TGOZ2602	-30.00	0.68	8.57	1.13	0.60	108.43	MODRSS			46.14	MODTES	57.00	CR	82.0		27M0G7W			4E	P		
USA	USAC_101	140.00	177.50	16.35				CB_FSS_USAC			44.06	MODTES	57.00	CL	87.0		27M0G7W			4A	P		
USA	USAC_102	140.00	177.50	16.35				CB_FSS_USAC			44.06	MODTES	57.00	CR	87.0		27M0G7W			4A	P		
YEM	YEM_101	11.00	48.29	14.53				CB_FSS_YEMA			47.78	MODTES	57.00	CR	82.0		27M0G7W			4O	P		
YEM	YEM_102	11.00	48.29	14.53				CB_FSS_YEMA			47.78	MODTES	57.00	CL	82.0		27M0G7W			4O	P		



TABLE 3A2 (WRC-19)  
Basic characteristics of the Regions 1 and 3 feeder-link Plan in the frequency band 17.3-18.1 GHz (sorted by administration)

1	2	3	4		5			6	7	8		9		10	11	12	13	14	15	16	17
			Boresight		Space station antenna characteristics					Space station antenna gain	Co-polar	Cross-polar	Code								
Admin. symbol	Beam identification	Orbital position	Long.	Lat.	Major axis	Minor axis	Orientation	Space station antenna code	Shaped beam	Co-polar	Cross-polar	Code	Gain	Type	Angle	c.r.p.	Designation of the space station	Group code	Status	Remarks	
AFG	AFG24381	5000	67.00	34.30	1.88	1.19	18.00	MODRSS		48.93		MODTES	57.00	CL		84.0	Z7N0G7W	71	P		
AFG	AFG24382	5000	67.00	34.30	1.88	1.19	18.00	MODRSS		40.93		MODTES	57.00	CR		84.0	Z7N0G7W	71	P		
AGL	AGL29600	-24.80	16.43	-12.37	2.66	1.75	77.43	MODRSS		37.77		MODTES	57.00	CR		84.0	Z7N0G7W		P		
ALB	ALB29600	62.00	19.50	41.37	0.60	0.60	69.35	MODRSS		48.88		MODTES	57.00	CL		82.6	Z7N0G7W		P		
ALG	ALG25152	-24.80	1.50	27.60	3.85	2.94	135.00	MODRSS		34.14		MODTES	57.00	CL		84.0	Z7N0G7W		P		
AND	AND34100	-37.00	1.60	42.50	0.60	0.60	0.00	MODRSS		48.88		MODTES	57.00	CL		83.0	Z7N0G7W		P		
ARM	ARM06400	22.80	44.99	39.95	0.73	0.60	148.17	MODRSS		48.02		MODTES	57.00	CR		84.0	Z7N0G7W		P		
ARS	ARS00075	17.00	44.60	23.40	4.21	2.48	145.00	MODRSS		34.26		MODTES	57.00	CL		84.0	Z7N0G7W	54	P		
ARS	ARS34000	17.00	44.60	23.40	4.21	2.48	145.00	MODRSS		34.28		MODTES	57.00	CL		84.0	Z7N0G7W	54	P		
AUS	AUS00400	152.00	93.00	-24.20	7.19	5.20	140.00	MODRSS		28.71		MODTES	57.00	CL		87.0	Z7N0G7W	30	P		
AUS	AUS00401	152.00	96.83	-12.19	0.60	0.60	0.00	MODRSS		48.88		MODTES	57.00	CL		87.0	Z7N0G7W	30	P		
AUS	AUS00402	152.00	105.69	-10.45	0.60	0.60	0.00	MODRSS		48.88		MODTES	57.00	CL		87.0	Z7N0G7W	30	P		
AUS	AUS00403	152.00	110.52	-66.28	0.60	0.60	0.00	MODRSS		48.88		MODTES	57.00	CL		87.0	Z7N0G7W	30	P		
AUS	AUS00404	152.00	58.94	-54.50	0.60	0.60	0.00	MODRSS		48.88		MODTES	57.00	CL		87.0	Z7N0G7W	30	P		
AUS	AUS00405	152.00	159.06	-31.52	0.60	0.60	0.00	MODRSS		48.88		MODTES	57.00	CL		87.0	Z7N0G7W	30	P		
AUS	AUS00406	152.00	167.93	-29.02	0.60	0.60	0.00	MODRSS		48.88		MODTES	57.00	CL		87.0	Z7N0G7W	30	P		
AUS	AUS0040A	152.00	35.36	-23.95	6.88	4.83	141.15	R123FR		29.23		MODTES	57.00	CL		87.0	Z7N0G7W	30	P		
AUS	AUS00900	152.00	135.00	-24.20	7.19	5.20	140.00	MODRSS		28.71		MODTES	57.00	CR		87.0	Z7N0G7W	41	P		
AUS	AUS00901	152.00	96.83	-12.19	0.60	0.60	0.00	MODRSS		48.88		MODTES	57.00	CR		87.0	Z7N0G7W	41	P		
AUS	AUS00902	152.00	105.69	-10.45	0.60	0.60	0.00	MODRSS		48.88		MODTES	57.00	CR		87.0	Z7N0G7W	41	P		
AUS	AUS00903	152.00	110.52	-66.28	0.60	0.60	0.00	MODRSS		48.88		MODTES	57.00	CR		87.0	Z7N0G7W	41	P		
AUS	AUS00904	152.00	159.06	-31.52	0.60	0.60	0.00	MODRSS		48.88		MODTES	57.00	CR		87.0	Z7N0G7W	41	P		
AUS	AUS00905	152.00	167.93	-29.02	0.60	0.60	0.00	MODRSS		48.88		MODTES	57.00	CR		87.0	Z7N0G7W	41	P		
AUS	AUS00906	152.00	110.52	-66.28	0.60	0.60	0.00	MODRSS		48.88		MODTES	57.00	CR		87.0	Z7N0G7W	41	P		
AUS	AUS00907	152.00	135.00	-24.20	7.19	5.20	140.00	MODRSS		28.71		MODTES	57.00	CR		87.0	Z7N0G7W	42	P		
AUS	AUS00908	152.00	96.83	-12.19	0.60	0.60	0.00	MODRSS		48.88		MODTES	57.00	CR		87.0	Z7N0G7W	42	P		
AUS	AUS00909	152.00	105.69	-10.45	0.60	0.60	0.00	MODRSS		48.88		MODTES	57.00	CR		87.0	Z7N0G7W	42	P		
AUS	AUS00910	152.00	110.52	-66.28	0.60	0.60	0.00	MODRSS		48.88		MODTES	57.00	CR		87.0	Z7N0G7W	42	P		
AUS	AUS00911	152.00	159.06	-31.52	0.60	0.60	0.00	MODRSS		48.88		MODTES	57.00	CR		87.0	Z7N0G7W	42	P		
AUS	AUS00912	152.00	167.93	-29.02	0.60	0.60	0.00	MODRSS		48.88		MODTES	57.00	CR		87.0	Z7N0G7W	42	P		
AUS	AUS00913	152.00	110.52	-66.28	0.60	0.60	0.00	MODRSS		48.88		MODTES	57.00	CR		87.0	Z7N0G7W	42	P		
AUS	AUS00914	152.00	135.00	-24.20	7.19	5.20	140.00	MODRSS		28.71		MODTES	57.00	CR		87.0	Z7N0G7W	42	P		
AUS	AUS00915	152.00	96.83	-12.19	0.60	0.60	0.00	MODRSS		48.88		MODTES	57.00	CR		87.0	Z7N0G7W	42	P		
AUS	AUS00916	152.00	105.69	-10.45	0.60	0.60	0.00	MODRSS		48.88		MODTES	57.00	CR		87.0	Z7N0G7W	42	P		
AUS	AUS00917	152.00	110.52	-66.28	0.60	0.60	0.00	MODRSS		48.88		MODTES	57.00	CR		87.0	Z7N0G7W	42	P		
AUS	AUS00918	152.00	159.06	-31.52	0.60	0.60	0.00	MODRSS		48.88		MODTES	57.00	CR		87.0	Z7N0G7W	42	P		
AUS	AUS00919	152.00	167.93	-29.02	0.60	0.60	0.00	MODRSS		48.88		MODTES	57.00	CR		87.0	Z7N0G7W	42	P		

1	2	3	4		5			6	7	8		9	10		11	12	13	14	15	16	17
			Admin. symbol	Beam identification	Orbital position	Bore-sight	Space station antenna characteristics			Major axis	Minor axis		Orientation	Space station antenna code							
AUS	AUS00700	164.00	93.00	-23.90	7.26	4.48	132.00	MODRSS		29.32		MODTES	57.00	CR	87.0		27N0G7W	31	P		
AUS	AUS00701	164.00	96.83	-12.19	0.60	0.60	0.00	MODRSS		48.88		MODTES	57.00	CR	87.0		27N0G7W	31	P		
AUS	AUS00702	164.00	105.69	-10.45	0.60	0.00	0.00	MODRSS		48.88		MODTES	57.00	CR	87.0		27N0G7W	31	P		
AUS	AUS00703	164.00	110.32	-86.28	0.60	0.60	0.00	MODRSS		48.88		MODTES	57.00	CR	87.0		27N0G7W	31	P		
AUS	AUS00704	164.00	68.94	-54.50	0.60	0.60	0.00	MODRSS		48.88		MODTES	57.00	CR	87.0		27N0G7W	31	P		
AUS	AUS00705	164.00	159.06	-31.52	0.60	0.00	0.00	MODRSS		48.88		MODTES	57.00	CR	87.0		27N0G7W	31	P		
AUS	AUS00706	164.00	67.93	-29.02	0.60	0.60	0.00	MODRSS		48.88		MODTES	57.00	CR	87.0		27N0G7W	31	P		
AUS	AUS0070A	164.00	36.92	-24.16	6.82	4.20	134.19	R123FR		29.87		MODTES	57.00	CR	87.0		27N0G7W	31	P		
AUS	AUS00800	164.00	136.00	-23.90	7.26	4.48	132.00	MODRSS		29.32		MODTES	57.00	CL	87.0		27N0G7W	44	P		
AUS	AUS00801	164.00	96.83	-12.19	0.60	0.60	0.00	MODRSS		48.88		MODTES	57.00	CL	87.0		27N0G7W	44	P		
AUS	AUS00802	164.00	105.69	-10.45	0.60	0.00	0.00	MODRSS		48.88		MODTES	57.00	CL	87.0		27N0G7W	44	P		
AUS	AUS00803	164.00	110.32	-86.28	0.60	0.60	0.00	MODRSS		48.88		MODTES	57.00	CL	87.0		27N0G7W	44	P		
AUS	AUS00804	164.00	68.94	-54.50	0.60	0.60	0.00	MODRSS		48.88		MODTES	57.00	CL	87.0		27N0G7W	44	P		
AUS	AUS00805	164.00	159.06	-31.52	0.60	0.00	0.00	MODRSS		48.88		MODTES	57.00	CL	87.0		27N0G7W	44	P		
AUS	AUS00806	164.00	67.93	-29.02	0.60	0.60	0.00	MODRSS		48.88		MODTES	57.00	CL	87.0		27N0G7W	44	P		
AUS	AUS00900	164.00	136.00	-23.90	7.26	4.48	132.00	MODRSS		29.32		MODTES	57.00	CR	87.0		27N0G7W	32	P		
AUS	AUS00901	164.00	96.83	-12.19	0.60	0.60	0.00	MODRSS		48.88		MODTES	57.00	CR	87.0		27N0G7W	32	P		
AUS	AUS00902	164.00	105.69	-10.45	0.60	0.00	0.00	MODRSS		48.88		MODTES	57.00	CR	87.0		27N0G7W	32	P		
AUS	AUS00903	164.00	110.32	-86.28	0.60	0.60	0.00	MODRSS		48.88		MODTES	57.00	CR	87.0		27N0G7W	32	P		
AUS	AUS00904	164.00	68.94	-54.50	0.60	0.60	0.00	MODRSS		48.88		MODTES	57.00	CR	87.0		27N0G7W	32	P		
AUS	AUS00905	164.00	159.06	-31.52	0.60	0.00	0.00	MODRSS		48.88		MODTES	57.00	CR	87.0		27N0G7W	32	P		
AUS	AUS00906	164.00	67.93	-29.02	0.60	0.60	0.00	MODRSS		29.87		MODTES	57.00	CR	87.0		27N0G7W	32	P		
AUS	AUS0090A	164.00	36.92	-24.16	6.82	4.20	134.19	R123FR		29.87		MODTES	57.00	CR	87.0		27N0G7W	32	P		
AUS	AUS04000	152.00	35.36	-23.95	6.88	4.83	141.15	R123FR		29.23		MODTES	57.00	CL	87.0		27N0G7W	40	P		
AUS	AUS04001	152.00	96.83	-12.19	0.60	0.60	0.00	MODRSS		48.88		MODTES	57.00	CL	87.0		27N0G7W	40	P		
AUS	AUS04002	152.00	105.69	-10.45	0.60	0.60	0.00	MODRSS		48.88		MODTES	57.00	CL	87.0		27N0G7W	40	P		
AUS	AUS04003	152.00	110.32	-86.28	0.60	0.60	0.00	MODRSS		48.88		MODTES	57.00	CL	87.0		27N0G7W	40	P		
AUS	AUS04004	152.00	68.94	-54.50	0.60	0.60	0.00	MODRSS		48.88		MODTES	57.00	CL	87.0		27N0G7W	40	P		
AUS	AUS04005	152.00	159.06	-31.52	0.60	0.60	0.00	MODRSS		48.88		MODTES	57.00	CL	87.0		27N0G7W	40	P		
AUS	AUS04006	152.00	67.93	-29.02	0.60	0.60	0.00	MODRSS		48.88		MODTES	57.00	CL	87.0		27N0G7W	40	P		
AUS	AUS00000	164.00	136.62	-24.16	6.82	4.20	134.19	R123FR		29.87		MODTES	57.00	CL	87.0		27N0G7W	43	P		
AUS	AUS00001	164.00	96.83	-12.19	0.60	0.60	0.00	MODRSS		48.88		MODTES	57.00	CL	87.0		27N0G7W	43	P		
AUS	AUS00002	164.00	105.69	-10.45	0.60	0.60	0.00	MODRSS		48.88		MODTES	57.00	CL	87.0		27N0G7W	43	P		
AUS	AUS00003	164.00	110.32	-86.28	0.60	0.60	0.00	MODRSS		48.88		MODTES	57.00	CL	87.0		27N0G7W	43	P		
AUS	AUS00004	164.00	68.94	-54.50	0.60	0.60	0.00	MODRSS		48.88		MODTES	57.00	CL	87.0		27N0G7W	43	P		
AUS	AUS00005	164.00	159.06	-31.52	0.60	0.60	0.00	MODRSS		48.88		MODTES	57.00	CL	87.0		27N0G7W	43	P		
AUS	AUS00006	164.00	67.93	-29.02	0.60	0.60	0.00	MODRSS		48.88		MODTES	57.00	CL	87.0		27N0G7W	43	P		

1	2	3	4		5			6	7	8		9			10	11	12	13	14	15	16	17
			Beam identification	Obital position	Long	Lat	Space station antenna characteristics			Space station antenna code	Shaped beam	Co-polar	Cross-polar	Code								
AUT	AUT01600	-18.80	10.31	49.47	1.82	0.92	15178	MODRSS		42.19	MODIES	57.00	CR	84.0			27M0G7W			P		
AZE	AZE06840	23.20	47.47	40.14	0.98	0.60	158.14	MODRSS		46.98	MODIES	57.00	CL	84.0			27M0G7W			P		
B01	B010700	11.00	29.90	-3.10	0.71	0.60	80.00	MODRSS		48.15	MODIES	57.00	CL	84.0			27M0G7W			P		
BEL	BEL01900	38.20	5.12	51.96	1.00	1.00	0.00	MODRSS		44.44	MODIES	57.00	CR	86.5			27M0G7W			P		
BEN	BEN23300	-19.20	2.20	9.50	1.44	0.68	97.00	MODRSS		44.54	MODIES	57.00	CL	84.0			27M0G7W			P		
BFA	BFA10700	-30.00	-1.50	12.20	1.45	1.14	29.00	MODRSS		42.26	MODIES	57.00	CL	84.0			27M0G7W			P		
BGD	BGD22000	74.00	90.30	23.60	1.46	0.84	135.00	MODRSS		43.56	MODIES	57.00	CR	84.0			27M0G7W			P		
BHR	BHR23500	34.00	50.50	26.10	0.80	0.60	0.00	MODRSS		48.88	MODIES	57.00	CR	86.0			27M0G7W			P		
BH	BH14800	56.00	18.22	43.97	0.60	0.60	90.00	MODRSS		48.88	MODIES	57.00	CR	84.0			27M0G7W			P		
BLR	BLR06200	37.80	28.04	53.18	1.17	0.60	9.68	MODRSS		45.96	MODIES	57.00	CL	84.0			27M0G7W			P		
BOT	B0729700	-0.80	23.30	-22.20	2.13	1.90	36.00	MODRSS		39.40	MODIES	57.00	CL	84.0			27M0G7W			P		
BRM	BRM29800	104.00	96.97	18.68	3.33	1.66	91.63	MODRSS		37.02	MODIES	57.00	CR	84.0			27M0G7W			P		
BRU	BRU3300A	74.00	114.70	4.40	0.60	0.60	0.00	MODRSS		48.88	MODIES	57.00	CR	84.0			27M0G7W			P		
BTN	BTN03100	86.00	90.44	27.05	0.72	0.60	175.47	MODRSS		48.11	MODIES	57.00	CR	84.0			27M0G7W			P		
BUL	BUL02000	-1.20	25.00	43.00	1.04	0.60	165.00	MODRSS		46.50	MODIES	57.00	CL	83.0			27M0G7W			P		
CAF	CAF25800	-13.20	21.00	6.30	2.25	1.68	31.00	MODRSS		38.67	MODIES	57.00	CR	84.0			27M0G7W			P		
CBG	CBG28900	86.00	104.89	12.79	1.12	0.94	32.89	MODRSS		44.22	MODIES	57.00	CR	84.0			27M0G7W			P		
CHN	CHN15400	62.00	101.90	33.50	5.10	2.80	143.00	MODRSS		32.90	MODIES	57.00	CR	84.0			27M0G7W			P	45	
CHN	CHN15500	62.00	101.90	33.50	5.10	2.80	143.00	MODRSS		32.90	MODIES	57.00	CL	84.0			27M0G7W			P	46	
CHN	CHN15800	134.00	113.21	34.27	6.40	3.16	107.4	MODRSS		31.39	MODIES	57.00	CL	84.0			27M0G7W			P	46	
CHN	CHN15900	134.00	113.21	34.27	6.40	3.16	107.4	MODRSS		31.39	MODIES	57.00	CR	84.0			27M0G7W			P	46	
CHN	CHN16000	92.20	108.10	33.70	5.00	4.00	148.00	MODRSS		31.44	MODIES	57.00	CR	84.0			27M0G7W			P	47	
CHN	CHN16100	92.20	108.10	33.70	5.00	4.00	148.00	MODRSS		31.44	MODIES	57.00	CL	84.0			27M0G7W			P	47	
CHN	CHN20000	122.00	113.55	22.20	0.60	0.60	0.00	MODRSS		48.88	MODIES	57.00	CL	84.0			27M0G7W			P		
CLN	CLN21900	50.00	80.60	7.70	1.18	0.60	106.00	MODRSS		45.95	MODIES	57.00	CL	84.0			27M0G7W			P		
COG	COG_100	-19.20	21.85	-3.40				CB,RSS,CODA		38.36	MODIES	57.00	CL	84.0			27M0G7W			P		
COG	COG23500	-13.20	14.60	-0.70	2.02	1.18	59.00	MODRSS		40.67	MODIES	57.00	CR	84.0			27M0G7W			P		
COM	COM20700	29.00	44.10	-12.10	0.76	0.60	149.00	MODRSS		47.86	MODIES	57.00	CR	84.0			27M0G7W			P		
CPV	CPV30100	-33.50	-24.12	16.09	0.77	0.63	94.46	MODRSS		47.56	MODIES	57.00	CL	84.0			27M0G7W			P	5,6	
CTI	CTI23700	-24.80	-5.86	7.39	1.46	1.29	126.59	MODRSS		41.73	MODIES	57.00	CR	84.0			27M0G7W			P		
CVA	CVA08300	-1.20	13.02	42.09	0.75	0.66	20.53	MODRSS		47.48	MODIES	57.00	CR	84.0			27M0G7W			P		
CVA	CVA08900	-1.20	13.02	42.09	0.75	0.66	20.53	MODRSS		47.48	MODIES	57.00	CR	84.0			27M0G7W			P		
CYP	CYP06800	-1.20	33.45	35.12	0.60	0.60	90.00	MODRSS		48.88	MODIES	57.00	CL	84.0			27M0G7W			P		
CZE	CZE14401	-12.80	16.77	46.78	1.71	0.89	149.15	MODRSS		42.64	MODIES	57.00	CR	84.0			27M0G7W			P		
CZE	CZE14402	-12.80	16.77	46.78	1.71	0.89	149.15	MODRSS		42.64	MODIES	57.00	CL	84.0			27M0G7W			P		
CZE	CZE14403	-12.80	16.77	46.78	1.71	0.89	149.15	MODRSS		42.64	MODIES	57.00	CL	84.0			27M0G7W			P	37	
D	D_08700	-18.80	10.31	49.47	1.82	0.92	15178	MODRSS		42.19	MODIES	57.00	CR	84.0			27M0G7W			P		

1	2	3	4		5			6	7	8		9			10	11	12	13	14	15	16	17
			Boresight		Space station antenna characteristics					Space station antenna code	Shaped beam	Space station antenna gain	Earth station antenna									
Admin. symbol	Beam identification	Orbital position	Long.	Lat.	Major axis	Minor axis	Orientation	Space station antenna code	Shaped beam	Co-polar	Cross-polar	Code	Gain	Type	Angle	e.i.r.p.	Power control	Designation of the space station	Group code	Status	Remarks	
	DJL	DJL06900	16.80	42.68	11.68	0.60	90.00	MDRRSS		48.88		MODES	57.00	CL		84.0		27M0G7W		P		
	DNK	DNK_100	-25.20	5.28	61.63			CB_RSS_DNK_A		48.88		MODES	57.00	CL		79.5		27M0G7W		P		
	DNK	DNK09000	-33.50	14.34	61.72	1.83	0.60	151.50	MDRRSS	44.05		MODES	57.00	CR		84.0		27M0G7W		P		
	DNK	DNK09100	-33.50	-14.94	63.79	1.52	0.60	168.57	MDRRSS	44.86		MODES	57.00	CR		84.0		27M0G7W		P		
	E	E_100	-30.00	-9.40	34.15			CB_RSS_E_A		44.79		MODES	57.00	CR		84.0		27M0G7W	01	P	6	
	E	HIS272D4	-30.00	-3.10	39.90				ECO	43.00	18.70	R13TES	57.00	CR		82.5		27M0G7W-	HISPASAT-1	01	PE	
	E	HIS272D6	-30.00	-3.10	39.90				ECO	43.00	18.70	R13TES	58.50	CR		83.5		27M0G7W-	HISPASAT-1	01	PE	
	E	HIS272D8	-30.00	-3.10	39.90				ECO	43.00	18.70	MODES	55.00	CR		82.5		33M0G7W-	HISPASAT-1	01	PE	
	E	HIS272D6	-30.00	-3.10	39.90				ECO	43.00	18.70	MODES	55.00	CR		82.5		33M0G7W-	HISPASAT-1	01	PE	
	E	HIS272D6	-30.00	-3.10	39.90				ECO	43.00	18.70	MODES	55.00	CR		82.5		33M0G7W-	HISPASAT-1	01	PE	
	E	HIS272D6	-30.00	-3.10	39.90				ECO	43.00	18.70	MODES	55.00	CR		82.5		33M0G7W-	HISPASAT-1	01	PE	
	E	HIS272D6	-30.00	-3.10	39.90				ECO	43.00	18.70	MODES	55.00	CR		82.5		33M0G7W-	HISPASAT-1	01	PE	
	E	HIS272D6	-30.00	-3.10	39.90				ECO	43.00	18.70	MODES	55.00	CR		82.5		33M0G7W-	HISPASAT-1	01	PE	
	E	HIS272D6	-30.00	-3.10	39.90				ECO	43.00	18.70	MODES	55.00	CR		82.5		33M0G7W-	HISPASAT-1	01	PE	
	E	HIS272D6	-30.00	-3.10	39.90				ECO	43.00	18.70	MODES	55.00	CR		82.5		33M0G7W-	HISPASAT-1	01	PE	
	E	HIS272D6	-30.00	-3.10	39.90				ECO	43.00	18.70	MODES	55.00	CR		82.5		33M0G7W-	HISPASAT-1	01	PE	
	E	HIS272D6	-30.00	-3.10	39.90				ECO	43.00	18.70	MODES	55.00	CR		82.5		33M0G7W-	HISPASAT-1	01	PE	
	E	HIS272D6	-30.00	-3.10	39.90				ECO	43.00	18.70	MODES	55.00	CR		82.5		33M0G7W-	HISPASAT-1	01	PE	
	E	HIS272D6	-30.00	-3.10	39.90				ECO	43.00	18.70	MODES	55.00	CR		82.5		33M0G7W-	HISPASAT-1	01	PE	
	E	HIS272D6	-30.00	-3.10	39.90				ECO	43.00	18.70	MODES	55.00	CR		82.5		33M0G7W-	HISPASAT-1	01	PE	
	E	HIS272D6	-30.00	-3.10	39.90				ECO	43.00	18.70	MODES	55.00	CR		82.5		33M0G7W-	HISPASAT-1	01	PE	
	E	HIS272D6	-30.00	-3.10	39.90				ECO	43.00	18.70	MODES	55.00	CR		82.5		33M0G7W-	HISPASAT-1	01	PE	
	E	HIS272D6	-30.00	-3.10	39.90				ECO	43.00	18.70	MODES	55.00	CR		82.5		33M0G7W-	HISPASAT-1	01	PE	
	E	HIS272D6	-30.00	-3.10	39.90				ECO	43.00	18.70	MODES	55.00	CR		82.5		33M0G7W-	HISPASAT-1	01	PE	
	E	HIS272D6	-30.00	-3.10	39.90				ECO	43.00	18.70	MODES	55.00	CR		82.5		33M0G7W-	HISPASAT-1	01	PE	
	E	HIS272D6	-30.00	-3.10	39.90				ECO	43.00	18.70	MODES	55.00	CR		82.5		33M0G7W-	HISPASAT-1	01	PE	
	E	HIS272D6	-30.00	-3.10	39.90				ECO	43.00	18.70	MODES	55.00	CR		82.5		33M0G7W-	HISPASAT-1	01	PE	
	E	HIS272D6	-30.00	-3.10	39.90				ECO	43.00	18.70	MODES	55.00	CR		82.5		33M0G7W-	HISPASAT-1	01	PE	
	E	HIS272D6	-30.00	-3.10	39.90				ECO	43.00	18.70	MODES	55.00	CR		82.5		33M0G7W-	HISPASAT-1	01	PE	
	E	HIS272D6	-30.00	-3.10	39.90				ECO	43.00	18.70	MODES	55.00	CR		82.5		33M0G7W-	HISPASAT-1	01	PE	
	E	HIS272D6	-30.00	-3.10	39.90				ECO	43.00	18.70	MODES	55.00	CR		82.5		33M0G7W-	HISPASAT-1	01	PE	
	E	HIS272D6	-30.00	-3.10	39.90				ECO	43.00	18.70	MODES	55.00	CR		82.5		33M0G7W-	HISPASAT-1	01	PE	
	E	HIS272D6	-30.00	-3.10	39.90				ECO	43.00	18.70	MODES	55.00	CR		82.5		33M0G7W-	HISPASAT-1	01	PE	
	E	HIS272D6	-30.00	-3.10	39.90				ECO	43.00	18.70	MODES	55.00	CR		82.5		33M0G7W-	HISPASAT-1	01	PE	
	E	HIS272D6	-30.00	-3.10	39.90				ECO	43.00	18.70	MODES	55.00	CR		82.5		33M0G7W-	HISPASAT-1	01	PE	
	E	HIS272D6	-30.00	-3.10	39.90				ECO	43.00	18.70	MODES	55.00	CR		82.5		33M0G7W-	HISPASAT-1	01	PE	
	E	HIS272D6	-30.00	-3.10	39.90				ECO	43.00	18.70	MODES	55.00	CR		82.5		33M0G7W-	HISPASAT-1	01	PE	
	E	HIS272D6	-30.00	-3.10	39.90				ECO	43.00	18.70	MODES	55.00	CR		82.5		33M0G7W-	HISPASAT-1	01	PE	
	E	HIS272D6	-30.00	-3.10	39.90				ECO	43.00	18.70	MODES	55.00	CR		82.5		33M0G7W-	HISPASAT-1	01	PE	
	E	HIS272D6	-30.00	-3.10	39.90				ECO	43.00	18.70	MODES	55.00	CR		82.5		33M0G7W-	HISPASAT-1	01	PE	
	E	HIS272D6	-30.00	-3.10	39.90				ECO	43.00	18.70	MODES	55.00	CR		82.5		33M0G7W-	HISPASAT-1	01	PE	
	E	HIS272D6	-30.00	-3.10	39.90				ECO	43.00	18.70	MODES	55.00	CR		82.5		33M0G7W-	HISPASAT-1	01	PE	
	E	HIS272D6	-30.00	-3.10	39.90				ECO	43.00	18.70	MODES	55.00	CR		82.5		33M0G7W-	HISPASAT-1	01	PE	
	E	HIS272D6	-30.00	-3.10	39.90				ECO	43.00	18.70	MODES	55.00	CR		82.5		33M0G7W-	HISPASAT-1	01	PE	
	E	HIS272D6	-30.00	-3.10	39.90				ECO	43.00	18.70	MODES	55.00	CR		82.5		33M0G7W-	HISPASAT-1	01	PE	
	E	HIS272D6	-30.00	-3.10	39.90				ECO	43.00	18.70	MODES	55.00	CR		82.5		33M0G7W-	HISPASAT-1	01	PE	
	E	HIS272D6	-30.00	-3.10	39.90				ECO	43.00	18.70	MODES	55.00	CR		82.5		33M0G7W-	HISPASAT-1	01	PE	
	E	HIS272D6	-30.00	-3.10	39.90				ECO	43.00	18.70	MODES	55.00	CR		82.5		33M0G7W-	HISPASAT-1	01	PE	
	E	HIS272D6	-30.00	-3.10	39.90				ECO	43.00	18.70	MODES	55.00	CR		82.5		33M0G7W-	HISPASAT-1	01	PE	
	E	HIS272D6	-30.00	-3.10	39.90				ECO	43.00	18.70	MODES	55.00	CR		82.5		33M0G7W-	HISPASAT-1	01	PE	
	E	HIS272D6	-30.00	-3.10	39.90				ECO	43.00	18.70	MODES	55.00	CR		82.5		33M0G7W-	HISPASAT-1	01	PE	
	E	HIS272D6	-30.00	-3.10	39.90				ECO	43.00	18.70	MODES	55.00	CR		82.5		33M0G7W-	HISPASAT-1	01	PE	
	E	HIS272D6	-30.00	-3.10	39.90				ECO	43.00	18.70	MODES	55.00	CR		82.5		33M0G7W-	HISPASAT-1	01	PE	
	E	HIS272D6	-30.00	-3.10	39.90				ECO	43.00	18.70	MODES	55.00	CR		82.5		33M0G7W-	HISPASAT-1	01	PE	
	E	HIS272D6	-30.00	-3.10	39.90				ECO	43.00	18.70	MODES	55.00	CR		82.5		33M0G7W-	HISPASAT-1	01	PE	
	E	HIS272D6	-30.00	-3.10	39.90				ECO	43.00	18.70	MODES	55.00	CR		82.5		33M0G7W-	HISPASAT-1	01	PE	
	E	HIS272D6	-30.00	-3.10	39.90				ECO	43.00	18.70	MODES	55.00	CR		82.5		33M0G7W-	HISPASAT-1	01	PE	
	E	HIS272D6	-30.00	-3.10	39.90				ECO	43.00	18.70	MODES	55.00	CR		82.5		33M0G7W-	HISPASAT-1	01	PE	
	E	HIS272D6	-30.00	-3.10	39.90				ECO	43.00	18.70	MODES	55.00	CR		82.5		33M0G7W-	HISPASAT-1	01	PE	
	E	HIS272D6	-30.00	-3.10	39.90				ECO	43.00	18.70	MODES	55.00	CR		82.5		33M0G7W-	HISPASAT-1	01	PE	
	E	HIS272D6	-30.00	-3.10	39.90				ECO	43.00	18.70	MODES	55.00	CR		82.5		33M0G7W-	HISPASAT-1	01	PE	
	E	HIS272D6	-30.00	-3.10	39.90				ECO	43.00	18.70	MODES	55.00	CR		82.5		33M0G7				

1	2	3	4		5			6	7	8		9			10	11	12	13	14	15	16	17
			Beam identification	Obital position	Long	Lat	Space station antenna characteristics			Space station antenna code	Shaped beam	Co-polar	Cross-polar	Code								
HRV	HRV14603	-12.80	46.77	46.78	1.71	0.89	149.15	MDRBS		42.64	MDTES	57.00	CL	84.0	27M0G7W					37	P	
I	I08200	9.00	12.87	40.74	1.99	1.35	144.20	MDRBS		40.14	MDTES	57.00	CR	84.0	27M0G7W						P	
IND	IND03700	68.00	93.00	25.50	1.46	1.13	40.00	MDRBS		42.27	MDTES	57.00	CL	84.0	27M0G7W						P	
IND	IND04701	68.00	93.30	11.10	1.92	0.60	96.00	MDRBS		43.83	MDTES	57.00	CR	84.0	27M0G7W						7E	P
IND	IND04702	68.00	93.30	11.10	1.92	0.60	96.00	MDRBS		43.83	MDTES	57.00	CL	84.0	27M0G7W						7E	P
IND	INDA_101	55.80	76.16	14.72			CB_RSS_INDA	CB_RSS_INDA		45.66	MDTES	57.00	CR	84.0	27M0G7W						7G	P
IND	INDA_102	55.80	76.16	14.72			CB_RSS_INDA	CB_RSS_INDA		45.66	MDTES	57.00	CL	84.0	27M0G7W						7G	P
IND	INDB_101	55.80	83.67	23.73			CB_RSS_INDB	CB_RSS_INDB		43.13	MDTES	57.00	CR	84.0	27M0G7W						7H	P
IND	INDB_102	55.80	83.67	23.73			CB_RSS_INDB	CB_RSS_INDB		43.13	MDTES	57.00	CL	84.0	27M0G7W						7H	P
IND	INDD_100	68.00	74.37	29.16			CB_RSS_INDD	CB_RSS_INDD		41.79	MDTES	57.00	CR	84.0	27M0G7W						7H	P
INS	INS2800	80.20	113.00	-1.40	6.73	3.33	160.00	MDRBS		30.94	MDTES	57.00	CR	84.0	27M0G7W						P	
INS	INS03501	104.00	115.20	-1.70	9.14	3.43	170.00	MDRBS	29.48	MDTES	57.00	CL	84.0	27M0G7W						7D	P	
INS	INS03502	104.00	115.20	-1.70	9.14	3.43	170.00	MDRBS	29.48	MDTES	57.00	CR	84.0	27M0G7W						7D	P	
IRL	IRL21100	-37.20	-8.25	53.22	0.72	0.60	157.56	MDRBS	48.08	MDTES	57.00	CR	84.0	27M0G7W							P	
IRN	IRN10900	34.00	54.20	32.40	3.82	1.92	146.00	MDRBS	36.03	MDTES	57.00	CL	83.0	27M0G7W							P	
ISL	ISL04900	-33.50	-19.00	64.90	1.00	0.60	177.00	MDRBS	46.67	MDTES	57.00	CL	83.0	27M0G7W							P	
ISL	ISL05000	-33.50	-14.94	63.79	1.52	0.60	168.57	MDRBS	44.86	MDTES	57.00	CR	84.0	27M0G7W							P	
ISR	ISR11000	-4.00	34.95	31.50	0.73	0.60	110.02	MDRBS	48.03	MDTES	57.00	CR	84.0	27M0G7W							P	
J	J000BS-3N	109.85	134.50	31.50	3.32	3.30	68.00	MDRBS	33.80	MDTES	57.00	CR	87.0	27M0G7W	BS-3N	02	PE					
J	J10985	109.85	134.50	31.50	3.32	3.30	68.00	MDRBS	33.80	MDTES	57.00	CR	87.0	34M5G7W						02	P	
J	J11100	110.00	134.50	31.50	3.32	3.30	68.00	MDRBS	33.80	MDTES	57.00	CR	87.0	34M5G7W						02	P	
J	J1110E	110.00	134.50	31.50	3.32	3.30	68.00	MDRBS	33.80	MDTES	57.00	CR	87.0	27M0G7W	BS-3M	02	PE					
JOR	JOR22400	11.00	37.45	34.02	1.47	0.91	73.16	MDRBS	43.19	MDTES	57.00	CL	85.0	27M0G7W							P	
KAZ	KAZ06800	56.40	65.73	46.40	4.58	1.76	177.45	MDRBS	35.38	MDTES	57.00	CL	84.0	27M0G7W							P	
KEN	KEN24900	-0.80	37.99	0.88	2.06	1.30	98.68	MDRBS	40.17	MDTES	57.00	CR	84.0	27M0G7W							P	
KEN	KGZ07000	50.00	73.91	41.32	1.47	0.64	5.05	MDRBS	44.75	MDTES	57.00	CR	84.0	27M0G7W							P	
KIR	KIR_100	176.00	-70.31	-0.56			CB_RSS_KIRA	CB_RSS_KIRA		42.60	MDTES	57.00	CL	84.0	27M0G7W							P
KOR	KOR11201	116.00	127.50	36.00	1.24	1.02	168.00	MDRBS	43.43	MDTES	57.00	CR	85.0	27M0G7W						03	P	
KOR	KOR11202	116.00	127.50	36.00	1.24	1.02	168.00	MDRBS	43.43	MDTES	57.00	CL	85.0	27M0G7W						03	P	
KRE	KRE2800	140.00	28.45	40.32	1.63	0.68	18.89	MDRBS	44.00	MDTES	57.00	CL	87.0	27M0G7W							P	
KWT	KWT11300	11.00	47.48	29.12	0.60	0.60	90.00	MDRBS	48.88	MDTES	57.00	CR	83.0	27M0G7W							P	
LAO	LAO28400	122.20	103.71	18.17	1.87	1.03	123.99	MDRBS	42.18	MDTES	57.00	CR	84.0	33M0G7W							P	
LBN	LBN27800	11.00	37.65	34.02	1.47	0.91	73.16	MDRBS	43.19	MDTES	57.00	CR	84.0	27M0G7W							P	
LBR	LBR24400	-33.50	-9.30	6.60	1.22	0.70	133.00	MDRBS	45.13	MDTES	57.00	CR	84.0	27M0G7W							P	
LBY	LBY28201	-24.80	17.50	26.30	3.68	1.84	130.00	MDRBS	36.14	MDTES	57.00	CL	84.0	27M0G7W							P	
LIE	LIE35300	-18.80	10.31	49.47	1.82	0.92	151.78	MDRBS	42.19	MDTES	57.00	CL	84.0	27M0G7W							P	
LSO	LSO03600	4.80	27.80	-29.80	0.66	0.60	36.00	MDRBS	48.47	MDTES	57.00	CL	84.0	27M0G7W							P	

1	2	3	4		5			6	7	8		9			10	11	12	13	14	15	16	17
			Beam identification	Obital position	Long	Lat	Major axis			Minor axis	Orientation	Space station antenna code	Shaped beam	Co-polar								
LIT	LIT06100	2320	24.52	56.11				CB_RSS_LITUA			47.92	MODIES	57.00	CR	84.0		27M0G7W			P		
LUX	LUX11400	2820	5.21	49.20	0.60	0.60	90.00	MODRRS			48.88	MODIES	57.00	CL	84.0		27M0G7W		09	P		
LVA	LVA06100	2320	24.52	56.11				CB_RSS_LVA			47.92	MODIES	57.00	CR	84.0		27M0G7W			P		
MAU	MAU_100	2900	59.61	-15.98				CB_RSS_MAU			41.42	MODIES	57.00	CL	84.0		27M0G7W			P		
MCO	MCO11600	3420	7.40	43.70	0.60	0.60	0.00	MODRRS			48.88	MODIES	57.00	CR	81.0		27M0G7W			P		
MDA	MDA06300	5000	28.45	46.59	0.60	0.60	90.00	MODRRS			48.88	MODIES	57.00	CR	84.0		27M0G7W			P		
MGG	MGG23600	2900	46.20	-18.60	2.57	0.80	67.00	MODRRS			41.32	MODIES	57.00	CL	84.0		27M0G7W			P		
MHL	MHL00800	14600	67.64	9.83	2.07	0.90	157.42	MODRRS			41.75	MODIES	57.00	CR	84.0		27M0G7W			P		
MKD	MKD14800	2280	21.53	41.50	0.60	0.60	90.00	MODRRS			48.88	MODIES	57.00	CL	84.0		27M0G7W			P		
MLA	M.LA_100	9150	108.07	3.92				CB_RSS_MLA			41.75	MODIES	57.00	CR	84.0		27M0G7W			P		
MLD	M.LD3600	5000	73.10	6.10	0.60	0.60	0.00	MODRRS			48.88	MODIES	57.00	CR	84.0		27M0G7W			P		
MLI	M.LI_100	-1920	-4.80	16.10				CB_RSS_MLI			41.11	MODIES	57.00	CR	87.0		27M0G7W			P		
M.LT	M.LT14700	2280	14.40	35.90	0.60	0.60	0.00	MODRRS			48.88	MODIES	57.00	CR	84.0		27M0G7W			P		
MNG	MNG24800	7400	101.95	46.79	3.32	1.04	169.27	MODRRS			39.07	MODIES	59.92	CL	86.9		27M0G7W			P		
MRC	MRC20900	-2520	-8.90	28.90	3.36	1.35	50.00	MODRRS			36.57	MODIES	57.00	CR	80.0		27M0G7W			P		
MTN	MTN_100	-36.80	-11.24	20.91				CB_RSS_MTN			37.55	MODIES	57.00	CR	86.0		27M0G7W			P		
MWI	MWI60800	4.80	33.79	-13.25	1.56	0.70	92.69	MODRRS			44.10	MODIES	57.00	CR	84.0		27M0G7W			P		
NGR	NGR11500	-3720	7.63	16.57	2.20	1.80	100.58	MODRRS			38.47	MODIES	57.00	CL	84.0		27M0G7W			P		
NOR	NOR12000	-0.80	16.70	61.58	1.84	0.95	177.31	MODRRS			42.02	MODIES	57.00	CR	84.0		27M0G7W		06	P		
NOR	NOR12100	-0.80	16.70	61.58	1.84	0.95	177.31	MODRRS			42.02	MODIES	57.00	CL	84.0		27M0G7W		06	P		
NRU	NRU30900	13400	67.00	-0.50	0.60	0.60	0.00	MODRRS			48.88	MODIES	57.00	CL	84.0		27M0G7W			P		
NZL	NZL_100	158.00	-174.35	-24.30				CB_RSS_NZLA			41.62	MODIES	57.00	CL	85.0		27M0G7W			P		
OWA	OWA12300	1720	55.60	21.00	1.88	1.02	100.00	MODRRS			36.60	MODIES	57.00	CL	84.0		27M0G7W			P		
PHL	PHL2800	9800	21.30	11.10	3.46	1.76	99.00	MODRRS			36.60	MODIES	57.00	CL	84.0		27M0G7W			P		
PLW	PLW00000	14000	32.88	5.51	1.30	0.60	55.41	MODRRS			45.53	MODIES	57.00	CR	84.0		27M0G7W			P		
POL	POL13200	5000	19.71	52.18	1.22	0.63	16.12	MODRRS			45.59	MODIES	57.00	CR	84.0		27M0G7W			P		
POR	POR_100	-3720	-15.92	37.65				CB_RSS_PORA			47.17	MODIES	57.00	CR	84.0		27M0G7W			P		
PSE	YYYY00001	-13.20	34.99	31.36	0.60	0.60	90.00	MODRRS			48.88	MODIES	57.00	CL	80.5		27M0G7W			P	8	
QAT	QAT24700	2000	51.69	25.35	0.60	0.60	90.00	MODRRS			48.88	MODIES	57.00	CL	84.0		27M0G7W			P		
ROU	ROU13800	5000	25.12	45.75	1.17	0.73	9.52	MODRRS			45.15	MODIES	57.00	CL	84.0		27M0G7W			P		
RRW	RRW31000	1100	30.00	-2.10	0.66	0.60	42.00	MODRRS			48.47	MODIES	57.00	CR	81.0		27M0G7W			P		
RUS	RSTREA11	36.00	38.00	53.00					COF		38.40	MODIES	57.00	CR	84.0		27M0G7W		05	PE		
RUS	RSTREA12	36.00	38.00	53.00					COF		38.40	MODIES	57.00	CL	84.0		27M0G7W		05	PE		
RUS	RSTRED11	36.00	38.00	53.00					COF		38.40	MODIES	57.00	CR	84.0		27M0G7W		05	PE		
RUS	RSTRED12	36.00	38.00	53.00					COF		38.40	MODIES	57.00	CL	84.0		27M0G7W		05	PE		
RUS	RSTRES01	36.00	38.00	53.00					COF		38.40	MODIES	57.00	CR	84.0		27M0G7W		05	PE		
RUS	RSTRES02	36.00	38.00	53.00					COF		38.40	MODIES	57.00	CL	84.0		27M0G7W		05	PE		

1	2	3	4		5			6	7	8		9		10		11	12	13	14	15	16	17
			Admin. symbol	Beam identification	Orbital position	Bore-sight	Space station antenna characteristics			Space station antenna code	Shaped beam	Space station antenna gain	Co-polar	Cross-polar	Earth station antenna							
			Long	Lat.	Major axis	Minor axis	Orientation			Co-polar	Cross-polar	Code	Gain	Type	Angle	e.i.r.p.	Power control	Designation of the space station	Group code	Status	Remarks	
RUS	RSTRSD21	56.00	65.00	63.00					COP	38.40	8.40	MODIES	57.00	CR	84.0		27M0G7W	RST-2	14	P		
RUS	RSTRSD22	56.00	65.00	63.00					COP	38.40	8.40	MODIES	57.00	CL	84.0		27M0G7W	RST-2	14	P		
RUS	RSTRSD31	86.00	97.00	62.00					COP	38.40	8.40	MODIES	57.00	CR	84.0		27M0G7W	RST-3	33	P		
RUS	RSTRSD32	86.00	97.00	62.00					COP	38.40	8.40	MODIES	57.00	CL	84.0		27M0G7W	RST-3	33	P		
RUS	RSTRSD51	140.00	68.00	56.00					COP	38.40	8.40	MODIES	57.00	CR	84.0		27M0G7W	RST-5	35	P		
RUS	RSTRSD52	140.00	68.00	56.00					COP	38.40	8.40	MODIES	57.00	CL	84.0		27M0G7W	RST-5	35	P		
RUS	RUS00401	110.00	118.22	51.52					COP	38.40	8.40	MODIES	57.00	CR	84.0		27M0G7W	RUS-4	34	P		
RUS	RUS00402	110.00	118.22	51.52					COP	38.40	8.40	MODIES	57.00	CL	84.0		27M0G7W	RUS-4	34	P		
S	S 13800	5.00	17.00	61.50	2.00	1.00	10.00	MODRSS	41.44			MODIES	57.00	CL	84.0		27M0G7W		04	P		
S	S 13900	5.00	17.00	61.50	2.00	1.00	10.00	MODRSS	41.44			MODIES	57.00	CL	84.0		27M0G7W		04	P		
SEY	SEY00000	42.50	51.96	-7.23	2.43	1.04	27.51	MODRSS	40.44			MODIES	57.00	CR	84.0		27M0G7W			P		
SLM	SLM00000	128.00	69.27	-8.40	1.35	1.08	118.59	MODRSS	42.81			MODIES	57.00	CL	84.0		27M0G7W			P		
SNO	SNO50700	-178.00	-171.70	-13.67	0.60	0.60	90.00	MODRSS	48.88			MODIES	57.00	CL	84.0		27M0G7W			P		
SNG	SNG31100	-36.80	12.80	43.90	0.60	0.60	0.00	MODRSS	48.88			MODIES	57.00	CL	83.0		27M0G7W			P		
SNG	SNG15100	88.00	103.86	1.42	0.92	0.72	175.12	MODRSS	46.25			MODIES	57.00	CL	84.0		27M0G7W			P		
SRB	SRB14800	-7.00	20.50	43.98	0.91	0.60	145.16	MODRSS	47.07			MODIES	57.00	CL	84.0		27M0G7W			P		
SRL	SRL25900	-33.50	-11.80	8.60	0.78	0.68	114.00	MODRSS	47.20			MODIES	57.00	CR	84.0		27M0G7W			P		
STP	STP24100	-7.00	7.00	0.80	0.60	0.60	0.00	MODRSS	48.88			MODIES	57.00	CL	84.0		27M0G7W			P		
SUI	SUI14000	-18.80	10.31	49.47	1.82	0.92	151.78	MODRSS	42.19			MODIES	57.00	CL	84.0		27M0G7W			P		
SVK	SVK14401	-12.80	16.77	46.78	1.71	0.89	149.15	MODRSS	42.64			MODIES	57.00	CR	84.0		27M0G7W			P		
SVK	SVK14402	-12.80	16.77	46.78	1.71	0.89	149.15	MODRSS	42.64			MODIES	57.00	CL	84.0		27M0G7W			P		
SVK	SVK14403	-12.80	16.77	46.78	1.71	0.89	149.15	MODRSS	42.64			MODIES	57.00	CL	84.0		27M0G7W			P		
SVN	SVN14800	33.80	45.01	46.18	0.60	0.60	90.00	MODRSS	48.88			MODIES	57.00	CR	82.0		27M0G7W			P		
SNZ	SNZ13300	4.80	31.93	-26.44	0.60	0.60	90.00	MODRSS	48.88			MODIES	57.00	CR	82.0		27M0G7W			P		
SVR	SVR23900	11.00	37.65	34.02	1.47	0.91	73.16	MODRSS	43.19			MODIES	57.00	CL	84.0		27M0G7W			P		
SVR	SVR33900	11.00	37.60	34.20	1.32	0.88	74.00	MODRSS	43.80			MODIES	57.00	CL	84.0		27M0G7W			P		
TCD	TCD14300	17.00	18.93	15.52	3.21	2.05	83.26	MODRSS	36.26			MODIES	57.00	CR	84.0		27M0G7W			P		
THA	THA14200	98.00	100.75	12.88	2.80	1.92	93.77	MODRSS	37.38			MODIES	57.00	CR	84.0		27M0G7W			P		
TJK	TJK06900	38.00	71.14	38.41	1.21	0.73	155.31	MODRSS	45.00			MODIES	57.00	CL	82.0		27M0G7W			P		
TMM	TMM06900	50.00	69.24	38.83	2.26	1.02	166.64	MODRSS	40.81			MODIES	57.00	CL	85.7		27M0G7W			P		
TLS	TLS00000	128.00	126.03	-8.72	0.66	0.60	13.92	MODRSS	48.50			MODIES	57.00	CR	84.0		27M0G7W			P		
TON	TON21500	170.75	-175.23	-18.19	1.59	0.60	71.33	MODRSS	44.64			MODIES	57.00	CR	84.0		27M0G7W			P		
TUN	TUN15900	-25.20	9.90	33.80	1.86	0.72	135.00	MODRSS	43.13			MODIES	57.00	CR	84.0		27M0G7W			P		
TUN	TUN27200	-25.20	2.50	32.00	3.59	1.75	175.00	MODRSS	36.47			MODIES	57.00	CR	84.0		27M0G7W			P		
TUR	TUR14300	42.00	35.14	38.99	3.99	1.10	0.03	MODRSS	39.00			MODIES	57.00	CL	84.0		27M0G7W			P		
TUV	TUV00000	176.00	177.81	-7.11	0.94	0.60	137.58	MODRSS	46.93			MODIES	57.00	CR	84.0		27M0G7W			P		
TZA	TZA22500	11.00	34.60	-6.20	2.41	1.72	129.00	MODRSS	38.27			MODIES	57.00	CR	84.0		27M0G7W			P		

1	2	3	4		5			6	7	8		9		10		11	12	13	14	15	16	17
			Admin. symbol	Beam identification	Orbital position	Bore-sight	Space station antenna characteristics			Space station antenna code	Shaped beam	Co-polar	Cross-polar	Earth station antenna	Type							
			Long.	Lat.	Major axis	Minor axis	Orientation			Code	Gain	Type	Angle	e.i.r.p.								
UAE	UAE27400	52.50	53.98	24.37	4.23	0.84	6.62	MODRSS		44.31	57.00	CR		84.0				27M0G7W			P	
USA	UGA05100	17.00	32.20	1.04	1.50	1.02	68.73	MODRSS		42.62	57.00	CR		84.0				27M0G7W			P	
UKR	UKR06300	38.20	31.82	48.19	2.32	0.95	177.32	MODRSS		41.01	57.00	CR		84.0				27M0G7W			P	
USA	GJM03101	122.00	95.46	13.21				CB_RSS_GJMA		43.61	57.00	CR		87.0				27M0G7W		7C	P	
USA	GJM03102	122.00	95.56	13.21				CB_RSS_GJMA		43.61	57.00	CL		87.0				27M0G7W		7C	P	
USA	MRA3200	121.80	155.46	13.21				CB_RSS_MRAA		43.61	57.00	CR		91.0				27M0G7W			P	
USA	PLM3200	170.00	-145.55	19.50				CB_RSS_PLMA		39.35	57.00	CL		87.0				27M0G7W			P	
USA	USAA_101	170.00	-145.55	19.50				CB_RSS_USAA		39.35	57.00	CR		87.0				27M0G7W		7A	P	
USA	USAA_102	170.00	-145.55	19.50				CB_RSS_USAA		39.35	57.00	CL		87.0				27M0G7W		7A	P	
UZB	UZB07100	33.80	63.80	41.21	2.96	0.89	159.91	MODRSS		40.84	57.00	CR		82.0				27M0G7W			P	
VTN	VTN2200	107.00	109.94	14.21	3.43	1.76	109.43	MODRSS		36.64	57.00	CR		84.0				27M0G7W			P	
VUT	VUT12801	140.00	168.00	-16.40	1.52	0.68	87.00	MODRSS		44.30	57.00	CL		84.0				27M0G7W		7B	P	
VUT	VUT12802	140.00	168.00	-16.40	1.52	0.68	87.00	MODRSS		44.30	57.00	CR		84.0				27M0G7W		7B	P	
ZMB	ZMB31400	-0.80	27.50	-13.10	2.38	1.48	39.00	MODRSS		38.98	57.00	CR		84.0				27M0G7W			P	
ZWE	ZWE13900	-0.80	29.60	-18.80	1.46	1.36	37.00	MODRSS		41.47	57.00	CL		85.0				27M0G7W			P	



COLUMN HEADINGS OF TABLES 3B1 AND 3B2

- Col. 1 *Nominal orbital position*, in degrees and hundredths of a degree from the Greenwich meridian (negative values indicate longitudes which are west of the Greenwich meridian; positive values indicate longitudes which are east of the Greenwich meridian).
- Col. 2 *Notifying administration symbol*.
- Col. 3 *Beam identification* (Column 2, normally, contains the symbol designating the administration or the geographical area taken from Table B1 of the Preface to the International Frequency Information Circular (BR IFIC), followed by the symbol designating the service area).
- Col. 4 Polarization (CL – circular left, CR – circular right).
- Col. 5 *Channel number/indication of minimum equivalent protection margin (EPM) for a given assignment derived from the set of values for all test points belonging to the given beam.*

TABLE 3B1

**Minimum equivalent protection margin in the Regions 1 and 3 feeder-link Plan in the frequency band 14.5-14.8 GHz (sorted by orbital position)**

1 Orbital position	2 Admin. symbol	3 Beam Identification	4 Polarization type	5													
				Channel number													
				2	3	4	5	6	7	8	9	10	11	12	13	14	
				Minimum equivalent protection margin													
-37.00	SEN	SEN22201	CL				40.8		39.6		39.6		39.6		39.6		40.7
-37.00	SEN	SEN22202	CR					39.6		39.6		39.6		39.6		40.7	
-30.00	TGO	TGO22601	CL				15.0		14.1		14.1		14.1		14.1		
-30.00	TGO	TGO22602	CR					14.1		14.1		14.1		14.1		15.0	
-25.00	GHA	GHA10801	CR				14.9		14.1		14.1		14.1		14.1		
-25.00	GHA	GHA10802	CL					14.1		14.1		14.1		14.1		14.9	
-19.20	NIG	NIG11901	CR				6.4		4.2		4.2		4.2		4.2		
-19.20	NIG	NIG11902	CL					4.2		4.2		4.2		4.2		6.4	
-18.80	NMB	NMB02501	CL				6.9		4.5		4.5		4.5		4.5		
-18.80	NMB	NMB02502	CR					4.5		4.5		4.5		4.5		6.9	
-13.00	CME	CME30001	CL				17.2		16.3		16.3		16.3		16.3		
-13.00	CME	CME30002	CR					16.3		16.3		16.3		16.3		17.2	
-7.00	SDN	SDN_101	CL				27.1		26.1		26.1		26.1		26.1		
-7.00	SDN	SDN_102	CR					26.1		26.1		26.1		26.1		27.1	
-1.00	MOZ	MOZ30701	CL				16.6		15.7		15.7		15.7		15.7		
-1.00	MOZ	MOZ30702	CR					15.7		15.7		15.7		15.7		16.6	
4.80	AFS	AFS02101	CL				11.9		11.0		11.0		11.0		11.0		
4.80	AFS	AFS02102	CR					11.0		11.0		11.0		11.0		11.9	
11.00	YEM	YEM_101	CR				47.8		47.3		47.3		47.3		47.3		
11.00	YEM	YEM_102	CL					47.3		47.3		47.3		47.3		47.8	

1	2	3	4	5													
				Channel number													
				2	3	4	5	6	7	8	9	10	11	12	13	14	
				Minimum equivalent protection margin													
34.00	IRN	IRN10901	CR		15.2		13.9		13.9		13.9		13.9		13.9		
34.00	IRN	IRN10902	CL			14.3		13.9		13.9		13.9		13.9		14.8	
36.00	ETH	ETH09201	CL				2.3		1.4		1.4		1.4		1.4		
36.00	ETH	ETH09202	CR					1.4		1.4		1.4		1.4		2.3	
37.80	SOM	SOM31201	CL				0.0		-0.3		-0.3		-0.3		-0.3		
37.80	SOM	SOM31202	CR					-0.3		-0.3		-0.3		-0.3		1.6	
38.20	PAK	PAK12701	CR		14.2		3.2		0.9		0.9		0.9		0.9		
38.20	PAK	PAK12702	CL			4.2		0.9		0.9		0.9		0.9		3.3	
42.50	SEY	SEY00001	CL				36.3		35.3		35.3		35.3		35.3		
42.50	SEY	SEY00002	CR					35.3		35.3		35.3		35.3		36.4	
50.00	IRQ	IRQ25601	CL				-0.1		-0.1		-0.1		-0.1		-0.1		
50.00	IRQ	IRQ25602	CR					-0.1		-0.1		-0.1		-0.1		2.4	
50.00	NPL	NPL12201	CR		38.2		3.9		1.2		1.2		1.2		1.2		
50.00	NPL	NPL12202	CL			4.6		1.2		1.2		1.2		1.2		3.9	
55.80	IND	INDA_101	CR		25.7		24.7		24.7		24.7		24.7		24.7		
55.80	IND	INDA_102	CL			24.7		24.7		24.7		24.7		24.7		25.6	
116.00	KOR	KO11201D	CL	7.5		7.5		7.5		7.5		7.5		7.5			
116.00	KOR	KOR11201	CL	7.5		7.5		7.5		7.5		7.5		7.5			
122.00	CHN	CHN19001	CL		47.7		47.7		47.7		47.7		47.7		50.7		
122.00	CHN	CHN19002	CR			42.0		42.0		42.0		42.0		42.0		999.9	
134.00	PNG	PNG13101	CR		26.1		25.2		25.2		25.2		25.2		25.2		
134.00	PNG	PNG13102	CL			25.2		25.2		25.2		25.2		25.2		26.1	
140.00	USA	USAC_101	CL		19.4		18.6		18.6		18.6		18.6		18.6		
140.00	USA	USAC_102	CR			18.6		18.6		18.6		18.6		18.6		19.4	





















## ARTICLE 10

**Interference**

10.1 The Member States shall endeavour to agree on the action required to reduce harmful interference which might be caused by the application of these provisions and the associated Plans.

## ARTICLE 11

**Period of validity of the provisions and associated Plans**

11.1 The provisions and associated Plans have been prepared in order to meet the requirements for feeder-links for the broadcasting-satellite service in the bands concerned for a period extending until at least 1 January 1994.

11.2 In any event, the provisions and associated Plans shall remain in force until their revision by a competent administrative radio conference convened in accordance with the relevant provisions of the Convention in force.

## ANNEX 1 (REV.WRC-19)

**Limits for determining whether a service of an administration is considered to be affected by a proposed modification to the Region 2 feeder-link Plan or by a proposed new or modified assignment in the Regions 1 and 3 feeder-link List or when it is necessary under this Appendix to seek the agreement of any other administration** (Rev.WRC-03)

**1** (SUP - WRC-2000)

**2** (SUP - WRC-2000)

**3** **Limits to the change in the overall equivalent protection margin with respect to frequency assignments in conformity with the Region 2 feeder-link Plan**<sup>33</sup> (WRC-2000)

With respect to the modification to the Region 2 feeder-link Plan and when it is necessary under this Appendix to seek the agreement of any other administration of Region 2, except in cases covered by Resolution 42 (Rev.WRC-19), an administration is considered as being affected if the overall

---

<sup>33</sup> With respect to § 3 the limit specified relates to the overall equivalent protection margin calculated in accordance with § 1.12 of Annex 3.

equivalent protection margin<sup>34</sup> corresponding to a test point of its entry in that Plan, including the cumulative effect of any previous modification to that Plan or any previous agreement, falls more than 0.25 dB below 0 dB, or, if already negative, more than 0.25 dB below the value resulting from:

- the feeder-link Plan as established by the 1983 Conference; *or*
- a modification of the assignment in accordance with this Appendix; *or*
- a new entry in the feeder-link Plan under Article 4; *or*
- any agreement reached in accordance with this Appendix except for Resolution 42 (Rev.WRC-19). (WRC-19)

**4 Limits to the interference into frequency assignments in conformity with the Regions 1 and 3 feeder-link Plan or with the Regions 1 and 3 feeder-link List or proposed new or modified assignments in the Regions 1 and 3 feeder-link List** (WRC-03)

Under assumed free-space propagation conditions, the power flux-density of a proposed new or modified assignment in the feeder-link List shall not exceed the value of  $-76 \text{ dB(W/(m}^2 \cdot 27 \text{ MHz))}$  at any point in the geostationary-satellite orbit, and the relative off-axis e.i.r.p. of the associated feeder-link antenna shall be in compliance with Fig. A (WRC-97 curves) of Annex 3. (WRC-03)

With respect to § 4.1.1 *a) or b)* of Article 4, an administration in Region 1 or 3 is considered by the Bureau as being affected if the minimum orbital spacing between the wanted and interfering space stations, under worst-case station-keeping conditions, is less than  $9^\circ$ . (WRC-03)

However, an administration is not considered as being affected if, under assumed free-space propagation conditions, the effect of the proposed new or modified assignments in the feeder-link List is that the feeder-link equivalent protection margin<sup>35</sup> corresponding to a test point of its assignment in the feeder-link Plan or the feeder-link List or for which the procedure of Article 4 has been initiated, including the cumulative effect of any previous modification to the feeder-link List or any previous agreement, does not fall more than 0.45 dB below 0 dB, or, if already negative, more than 0.45 dB below the value resulting from:

- the Regions 1 and 3 feeder-link Plan and List as established by WRC-2000; *or*
- a proposed new or modified assignment to the feeder-link List in accordance with this Appendix; *or*
- a new entry in the Regions 1 and 3 feeder-link List as a result of the successful application of Article 4 procedures. (WRC-03)

For a proposed new or modified assignment to the feeder-link List, in the interference analysis, for each test point, the antenna characteristics described in § 3.5 of Annex 3 shall apply. (WRC-03)

---

<sup>34</sup> For the definition of the overall equivalent protection margin, see § 1.11 of Annex 5 to Appendix 30.

<sup>35</sup> For the definition of the equivalent protection margin, see § 1.7 of Annex 3.

**5 Limits applicable to protect a frequency assignment in the frequency bands 17.3-18.1 GHz (Regions 1 and 3) and 17.3-17.8 GHz (Region 2) to a receiving space station in the fixed-satellite service (Earth-to-space)**

An administration in Region 1 or 3 is considered as being affected by a proposed modification in Region 2, with respect to § 4.2.2 *a*) or 4.2.2 *b*) of Article 4, or an administration in Region 2 is considered as being affected by a proposed new or modified assignment in the Regions 1 and 3 feeder-link List, with respect to § 4.1.1 *c*) of Article 4, when the power flux-density arriving at the receiving space station of a broadcasting-satellite feeder-link would cause an increase in the noise temperature of the feeder-link space station which exceeds the threshold value of  $\Delta T/T$  corresponding to 6%, where  $\Delta T/T$  is calculated in accordance with the method given in Appendix 8, except that the maximum power densities per hertz averaged over the worst 1 MHz are replaced by power densities per hertz averaged over the necessary bandwidth of the feeder-link carriers. (WRC-03)

Interim systems of Region 2 in accordance with Resolution 42 (Rev.WRC-19) shall not be taken into consideration when applying the above paragraph to proposed new or modified assignments in the Regions 1 and 3 feeder-link List. However, the above paragraph shall be applied to Region 2 interim systems with respect to Regions 1 and 3 administrations, referred to in § 5.2 *b*) of Resolution 42 (Rev.WRC-19). (WRC-19)

**6 Limits applicable to protect a frequency assignment in the frequency bands 14.5-14.8 GHz and 17.8-18.1 GHz (Region 2) to a receiving feeder-link space station in the fixed-satellite service (Earth-to-space) or a frequency assignment in the frequency bands 14.5-14.75 GHz (in countries listed in Resolution 163 (WRC-15)) and 14.5-14.8 GHz (in countries listed in Resolution 164 (WRC-15)) to a receiving space station in the fixed-satellite service (Earth-to-space) not subject to a Plan** (WRC-19)

With respect to § 4.1.1 *d*) of Article 4, an administration is considered affected by a proposed new or modified assignment in the Regions 1 and 3 feeder-link List when the power flux-density arriving at the receiving space station of a broadcasting-satellite feeder link in Region 2 or the receiving space station of the fixed-satellite service uplinks not subject to a Plan in all Regions of that administration would cause an increase in the noise temperature of the receiving uplink space station which exceeds the threshold value of  $\Delta T/T$  corresponding to 6%, where  $\Delta T/T$  is calculated in accordance with the method given in Appendix 8, except that the maximum power densities per hertz averaged over the worst 1 MHz are replaced by power densities per hertz averaged over the necessary bandwidth of the feeder-link carriers. (WRC-15)

## ANNEX 2 (REV.WRC-03)

**Basic characteristics to be furnished in notices relating to feeder-link stations in the fixed-satellite service operating in the frequency bands 14.5-14.8 GHz and 17.3-18.1 GHz**

These data are listed in Appendix 4.

## ANNEX 3

**Technical data used in establishing the provisions and associated Plans and Regions 1 and 3 feeder-link List, which should be used for their application**<sup>36</sup> (Rev.WRC-03)

**1 Definitions****1.1 Feeder link**

The term feeder link, as defined in No. 1.115, is further qualified to indicate a fixed-satellite service link in the frequency band 17.3-17.8 GHz in the Region 2 broadcasting-satellite service Plan and in the frequency bands 14.5-14.8 GHz for countries outside Europe, and 17.3-18.1 GHz in the Regions 1 and 3 Plan, from any earth station within the feeder-link service area to the associated space station in the broadcasting-satellite service.

**1.2 Feeder-link beam area**

The area delineated by the intersection of the half-power beam of the satellite receiving antenna with the surface of the Earth.

**1.3 Feeder-link service area**

The area on the surface of the Earth within the feeder-link beam area within which the administration responsible for the service has the right to locate transmitting earth stations for the purpose of providing feeder-links to broadcasting-satellite space stations.

**1.4 Nominal orbital position**

The longitude of a position in the geostationary-satellite orbit associated with a frequency assignment to a space station in a space radiocommunication service. The position is given in degrees from the Greenwich meridian.

---

<sup>36</sup> In revising this Annex at WRC-97 and at WRC-2000, no changes were made to the technical data applicable to the Region 2 feeder-link Plan. However, for all three Regions it should be noted that some of the parameters of networks proposed as modifications to the Region 2 feeder-link Plan and the Regions 1 and 3 feeder-link Lists may differ from the technical data presented herein. (WRC-2000)

**1.5 Adjacent channel**

The RF channel in the broadcasting-satellite service frequency Plan, or in the associated feeder-link frequency Plan, which is situated immediately higher or lower in frequency with respect to the reference channel.

**1.6 Second adjacent channel**

The RF channel in the broadcasting-satellite service frequency Plan, or in the associated feeder-link frequency Plan, which is situated immediately beyond either of the adjacent channels, with respect to the reference channel.

**1.7 Feeder-link equivalent protection margin for Regions 1 and 3<sup>37</sup> (WRC-2000)**

The feeder-link equivalent protection margin ( $M_u$ ) is given by the formula:

$$M_u = -10 \log \left( 10^{-M_1/10} + 10^{-M_2/10} + 10^{-M_3/10} \right) \quad \text{dB}$$

where:

$M_1$ : is the value in dB of the protection margin for the same channel, i.e.:

$$M_1 = \left[ \frac{\text{wanted power}}{\text{sum of the co-channel interfering powers}} \right] - \text{co-channel protection ratio}$$

$M_2$  and  $M_3$ : are the values in dB of the protection margin for the upper and lower adjacent channels, respectively, i.e.:

$$M_2 = \left[ \frac{\text{wanted power}}{\text{sum of the upper adjacent channel interfering powers}} \right] - \text{adjacent channel protection ratio}$$

$$M_3 = \left[ \frac{\text{wanted power}}{\text{sum of the lower adjacent channel interfering powers}} \right] - \text{adjacent channel protection ratio}$$

All powers are evaluated at the receiver input. All protection ratios are given in § 3.3.

---

<sup>37</sup> This quantity is used in the alternative formula for the overall equivalent protection margin given in § 1.12. However, in certain cases (e.g. when the channel spacing and/or bandwidth are different from the values given in § 3.5 and 3.8 of Annex 5 to Appendix 30) the Bureau will use the worst-case approach until a relevant ITU-R Recommendation is incorporated in this Annex by reference. (WRC-2000)



**1.8 Overall carrier-to-interference (C/I) ratio**

The overall C/I ratio is the ratio of the wanted carrier power to the sum of all interfering RF powers in a given channel including both feeder-links and downlinks. The overall C/I ratio due to interference from the given channel is calculated as the reciprocal of the sum of the reciprocals of the feeder-link C/I ratio and the downlink C/I ratio referred to the satellite receiver input and earth station receiver input, respectively<sup>38</sup>.

**1.9 Overall co-channel protection margin**

The overall co-channel protection margin in a given channel is the difference (dB) between the overall co-channel C/I ratio and the co-channel protection ratio.

**1.10 Overall adjacent channel protection margin**

The overall adjacent channel protection margin is the difference (dB) between the overall adjacent channel C/I ratio and the adjacent channel protection ratio.

**1.11 Overall second adjacent channel protection margin**

The overall second adjacent channel protection margin is the difference (dB) between the overall second adjacent channel C/I ratio and the second adjacent channel protection ratio.

**1.12 Overall equivalent protection margin**

The overall equivalent protection margin *M* is given in dB by the expression<sup>39</sup>:

$$M = -10 \log \left( \sum_{i=1}^n 10^{(-M_i/10)} \right)$$

where:

*n*: is generally equal to 3 for Regions 1 and 3, *n* is equal to 5 for Region 2

*M*<sub>1</sub>: overall co-channel protection margin (dB) (as defined in § 1.9)

*M*<sub>2</sub>, *M*<sub>3</sub>: overall adjacent channel protection margins for the upper and lower adjacent channels, respectively (dB) (as defined in § 1.10)

*M*<sub>4</sub>, *M*<sub>5</sub>: overall second adjacent channel protection margins for the upper and lower second adjacent channels, respectively (dB) as defined in § 1.11).<sup>40</sup>

---

<sup>38</sup> In Region 2, there are a total of five overall C/I ratios used in the analysis of the Plan, namely, co-channel, upper and lower adjacent channels and upper and lower second adjacent channels. In Regions 1 and 3, three ratios are used, namely, co-channel and upper and lower adjacent channels.

<sup>39</sup> This formula is also used to calculate the overall equivalent protection margin of the assignments notified, which are in conformity with this Appendix, brought into use, and for which the date of bringing into use has been confirmed to the Bureau before 27 October 1997.

<sup>40</sup> *M*<sub>4</sub> and *M*<sub>5</sub> are applicable only for Region 2. (WRC-2000)

The adjective “equivalent” indicates that the protection margins for all interference sources from the adjacent and second adjacent as well as co-channel interference sources have been included.

The following alternative formula for overall equivalent protection margin was used at the 1988 Conference (WARC Orb-88) in developing the original feeder-link Plan for Regions 1 and 3. It may be used as a tool to assess the relative contributions of the feeder link and downlink to the overall equivalent protection margin defined above.

$$M = -10 \log \left( 10^{-(M_u + R_{cu})/10} + 10^{-(M_d + R_{cd})/10} \right) - R_{co}$$

where:

$M_u$ : equivalent protection margin for the feeder link (as defined in § 1.7)

$M_d$ : equivalent protection margin for the downlink (as defined in § 3.4, Annex 5 to Appendix 30)

$R_{cu}$ : co-channel feeder-link protection ratio

$R_{cd}$ : co-channel downlink protection ratio

$R_{co}$ : co-channel overall protection ratio.

The values of the protection ratios used for the 1988 feeder-link Plan were as follows:

$$R_{cu} = 40 \text{ dB}$$

$$R_{cd} = 31 \text{ dB}$$

$$R_{co} = 30 \text{ dB}$$

The adjective “equivalent” indicates that the protection margins for all interference sources from the adjacent channels as well as co-channel interference sources have been included.

The corresponding values for analysing the 1997 feeder-link Plan are:

$$R_{cu} = 30 \text{ dB}$$

$$R_{cd} = 24 \text{ dB}$$

$$R_{co} = 23 \text{ dB}$$

However, the latter values are restricted to the case of channels having the standard channel spacing and necessary bandwidth given in § 3.5 and 3.8, respectively, of Annex 5 to Appendix 30.

WRC-2000 generally applied the following protection ratio values for development of the WRC-2000 Regions 1 and 3 feeder-link Plan:

$$R_{cu} = 27 \text{ dB}$$

$$R_{cd} = 21 \text{ dB}$$

(WRC-2000)

These values were used for all assignments in WRC-2000 planning except those for which WRC-2000 adopted different values (see § 3.3). The planning at WRC-2000 was based on use of the equivalent protection margin criterion. (WRC-2000)

## 2 Radio propagation factors

The propagation loss on an Earth-to-space path is equal to the free-space path loss plus the atmospheric absorption loss plus the rain attenuation exceeded for 1% of the worst month in Region 2. In Regions 1 and 3, the atmospheric absorption loss is not included.

### 2.1 Atmospheric absorption

For Region 2 (see Fig. 2)

The loss due to atmospheric absorption (i.e. clear-sky attenuation) is given by:

$$A_a = \frac{92.20}{\cos \theta} (0.020F_o + 0.008\rho F_w) \quad \text{dB} \quad \text{for } \theta < 5^\circ$$

where:

$$F_o = \left\{ 24.88 \tan \theta + 0.339 \sqrt{1416.77 \tan^2 \theta + 5.51} \right\}^{-1}$$

$$F_w = \left\{ 40.01 \tan \theta + 0.339 \sqrt{3663.79 \tan^2 \theta + 5.51} \right\}^{-1}$$

and:

$$A_a = \frac{0.0478 + 0.0118\rho}{\sin \theta} \quad \text{dB} \quad \text{for } \theta \geq 5^\circ$$

where:

$\theta$ : elevation angle (degrees)

$\rho$ : surface water vapour concentration, g/m<sup>3</sup>, with

$\rho = 10$  g/m<sup>3</sup> for rain climatic zones A to K and

$\rho = 20$  g/m<sup>3</sup> for rain climatic zones M to P.

For Regions 1 and 3 (see Figs. 1 and 3 taken from Recommendation ITU-R P.837-1)

In the Regions 1 and 3 feeder-link Plan, the atmospheric absorption loss is not included for the calculation of margins.

### 2.2 Rain attenuation

The propagation model for feeder links using circularly polarized signals is based on the value of rain attenuation for 1% of the worst month.

Figures 1, 2 and 3 give the rain climatic zones for Regions 1, 2 and 3.

Figure 4 presents a plot of rain attenuation of circularly polarized signals exceeded for 1% of the worst month at 17.5 GHz as a function of earth station latitude and elevation angle for each of the rain climatic zones in Region 2.

For calculation, the following data are needed:

- $R_{0.01}$ : point rainfall rate for the location exceeded for 0.01% of an average year (mm/h)
- $h_0$ : height above mean sea level of the earth station (km)
- $\theta$ : elevation angle (degrees)
- $f$ : frequency (GHz)
- $\zeta$ : latitude of earth station (degrees).

Mean frequencies will be used for calculations for the frequency bands, i.e. 17.7 GHz and 14.65 GHz for Regions 1 and 3, 17.5 GHz for Region 2.

The calculation procedure used for the Region 2 feeder-link Plan and for the original 1988 Regions 1 and 3 feeder-link Plan consists of the following seven steps:

*Step 1:* the mean zero-degree isotherm height  $h_F$  is:

$$h_F = 5.1 - 2.15 \log \left[ 1 + 10 \frac{(|\zeta| - 27)}{25} \right] \quad \text{km}$$

*Step 2:* the rain height  $h_R$  is:

$$h_R = C \cdot h_F \quad \text{km}$$

where:

$$\begin{aligned}
 C &= 0.6 && \text{for} && 0^\circ \leq && |\zeta| < 20^\circ \\
 C &= 0.6 + 0.02 (|\zeta| - 20) && \text{for} && 20^\circ \leq && |\zeta| < 40^\circ \\
 C &= 1 && \text{for} && |\zeta| \geq && 40^\circ
 \end{aligned}$$

*Step 3:* the slant-path length,  $L_S$ , below the rain height is:

$$L_S = \frac{2(h_R - h_0)}{\left[ \sin^2 \theta + 2 \frac{(h_R - h_0)}{R_e} \right]^{1/2} + \sin \theta} \quad \text{km}$$

where  $R_e$  is the effective radius of the Earth (8 500 km).

*Step 4:* the horizontal projection,  $L_G$ , of the slant-path is:

$$L_G = L_S \cos \theta \quad \text{km}$$

*Step 5:* the rain path reduction factor  $r_{0.01}$ , for 0.01% of the time is:

$$r_{0.01} = \frac{90}{90 + 4L_G}$$

Step 6: the specific attenuation  $\gamma_R$  is determined from:

$$\gamma_R = k (R_{0.01})^\alpha \quad \text{dB/km}$$

where  $R_{0.01}$  is given in Table 1 for each rain climatic zone. The frequency dependent coefficients  $k$  and  $\alpha$  are given in Table 2 and the rain climatic zones are given in Figs. 1, 2 and 3 for Regions 1, 2 and 3.

TABLE 1  
Rainfall intensity (R) for the rain climatic zones (exceeded for 0.01% of an average year)

Rain climatic zone	A	B	C	D	E	F	G	H	J	K	L	M	N	P	Q
Rainfall intensity (mm/h)	8	12	15	19	22	28	30	32	35	42	60	63	95	145	115

TABLE 2  
Frequency dependent coefficients

Frequency (GHz)	$k$	$\alpha$	
14.65	0.0327	1.149	For Regions 1 and 3
17.5	0.0521	1.114	For Region 2
17.7	0.0531	1.110	For Regions 1 and 3

Step 7: the attenuation exceeded for 1% of the worst month is:

$$A_{1\%} = 0.223 \gamma_R L_S r_{0.01} \quad \text{dB for Regions 1 and 3}$$

$$A_{1\%} = 0.21 \gamma_R L_S r_{0.01} \quad \text{dB for Region 2.}$$

For calculation of the permissible increase in e.i.r.p. to overcome rain fading (power control, see § 3.11.1) in the Regions 1 and 3 Plan revised by WRC-97, the same calculation procedure is used with the following changes to conform to Recommendation ITU-R P.618-5.

To calculate the rain height  $h_R$ , Steps 1 and 2 are replaced by:

$$h_R = \begin{cases} 5 - 0.075 (\zeta - 23) & \text{for } \zeta > 23^\circ & \text{Northern Hemisphere} \\ 5 & \text{for } 0^\circ \leq \zeta \leq 23^\circ & \text{Northern Hemisphere} \\ 5 & \text{for } 0^\circ \geq \zeta \geq -21^\circ & \text{Southern Hemisphere} \\ 5 + 0.1 (\zeta + 21) & \text{for } -71^\circ \leq \zeta < -21^\circ & \text{Southern Hemisphere} \\ 0 & \text{for } \zeta < -71^\circ & \text{Southern Hemisphere} \end{cases}$$

Steps 3 and 4 remain the same. However, to calculate the rain path reduction factor  $r_{0.01}$ , for 0.01% of the time, the equation of Step 5 is replaced by:

$$r_{0.01} = \frac{1}{1 + L_G/L_0}$$

where:

$$L_0 = 35 \exp(-0.015 R_{0,01})$$

and  $R_{0,01}$  is given in Table 1 for each rain climatic zone.

Step 6 remains the same except the frequency dependent coefficients  $k$  and  $\alpha$  shall be obtained from Recommendation ITU-R P.838-3. (WRC-07)

Step 7 should be replaced as follows:

$$\frac{A_p}{A_{0,01}} = 0.12 p^{-(0.546 + 0.043 \log p)}$$

where:

$$p (\%) = 0.30 p_w (\%)^{1.15} \quad (\text{Recommendation ITU-R P.841})$$

$p$  is the average annual time percentage of excess corresponding to desired worst-month time percentage of excess  $p_w$ .

### 2.3 Rain attenuation limit

In the analysis of the Plan for Region 2, a maximum rain attenuation on the feeder link of 13 dB was considered assuming that other means would be used at the implementation stage to compensate for larger rain attenuation on the feeder link.

In the analysis of the Regions 1 and 3 Plan, no rain attenuation is included in the margins.

### 2.4 Depolarization

Rain and ice can cause depolarization of radio frequency signals. The level of the co-polar component relative to the depolarized component is given by the cross-polarization discrimination (XPD) ratio. For the feeder link, the XPD ratio (dB) not exceeded for 1% of the worst month, is given by:

$$XPD = 30 \log f - 40 \log (\cos \theta) - V \log A_p \quad \text{for } 5^\circ \leq \theta \leq 60^\circ$$

where:

$$V = 20 \quad \text{for 14.5-14.8 GHz}$$

and

$$V = 23 \quad \text{for 17.3-18.1 GHz}$$

where:

$A_p$ : co-polar rain attenuation exceeded for 1% of the worst month

$f$ : frequency (GHz)

$\theta$ : elevation angle (degrees).

To calculate the depolarization value to be used for power control in the Regions 1 and 3 Plan, the following algorithm (Steps 1 to 8), which was obtained from Recommendation ITU-R P.618-5, shall be used.

## AP30A-104

To calculate long-term statistics of depolarization from rain attenuation statistics the following parameters are needed:

$A_p$ : rain attenuation (dB) exceeded for the required percentage of time,  $p$ , for the path in question, commonly called co-polar attenuation (CPA)

$\tau$ : tilt angle of the linearly-polarized electric field vector with respect to the horizontal (for circular polarization use  $\tau = 45^\circ$ )

$f$ : frequency (GHz)

$\theta$ : path elevation angle (degrees).

The method described below to calculate XPD statistics from rain attenuation statistics for the same path is valid for  $8 \text{ GHz} \leq f \leq 35 \text{ GHz}$  and  $\theta \leq 60^\circ$ .

*Step 1:* calculate the frequency-dependent term:

$$C_f = 30 \log f \quad \text{for} \quad 8 \text{ GHz} \leq f \leq 35 \text{ GHz}$$

*Step 2:* calculate the rain attenuation dependent term:

$$C_A = V(f) \log A_p$$

where:

$$V(f) = 12.8 f^{0.19} \quad \text{for} \quad 8 \text{ GHz} \leq f \leq 20 \text{ GHz}$$

$$V(f) = 22.6 \quad \text{for} \quad 20 \text{ GHz} < f \leq 35 \text{ GHz}$$

*Step 3:* calculate the polarization improvement factor:

$$C_\tau = -10 \log [1 - 0.484 (1 + \cos 4\tau)]$$

The improvement factor  $C_\tau = 0$  for  $\tau = 45^\circ$  and reaches a maximum value of 15 dB for  $\tau = 0^\circ$  or  $90^\circ$ .

*Step 4:* calculate the elevation angle dependent term:

$$C_\theta = -40 \log (\cos \theta) \quad \text{for} \quad \theta \leq 60^\circ$$

*Step 5:* calculate the canting angle dependent term:

$$C_\sigma = 0.0052 \sigma^2$$

$\sigma$  is the effective standard deviation of the raindrop canting angle distribution, expressed in degrees;  $\sigma$  takes the value  $0^\circ$ ,  $5^\circ$ ,  $10^\circ$  and  $15^\circ$  for 1%, 0.1%, 0.01% and 0.001% of the time, respectively.

*Step 6:* calculate rain XPD not exceeded for  $p\%$  of the time:

$$XPD_{rain} = C_f - C_A + C_\tau + C_\theta + C_\sigma \quad \text{dB}$$

*Step 7:* calculate the ice crystal dependent term:

$$C_{ice} = XPD_{rain} (0.3 + 0.1 \log p) / 2 \quad \text{dB}$$

*Step 8:* calculate the XPD not exceeded for  $p\%$  of the time, including the effects of ice:

$$XPD_p = XPD_{rain} - C_{ice} \quad \text{dB}$$

For values of  $\theta$  greater than  $60^\circ$ , use  $\theta = 60^\circ$  in the above equations.

FIGURE 1  
Rain-climatic zones for Regions 1 and 3 between  
longitudes 45° W and 105° E

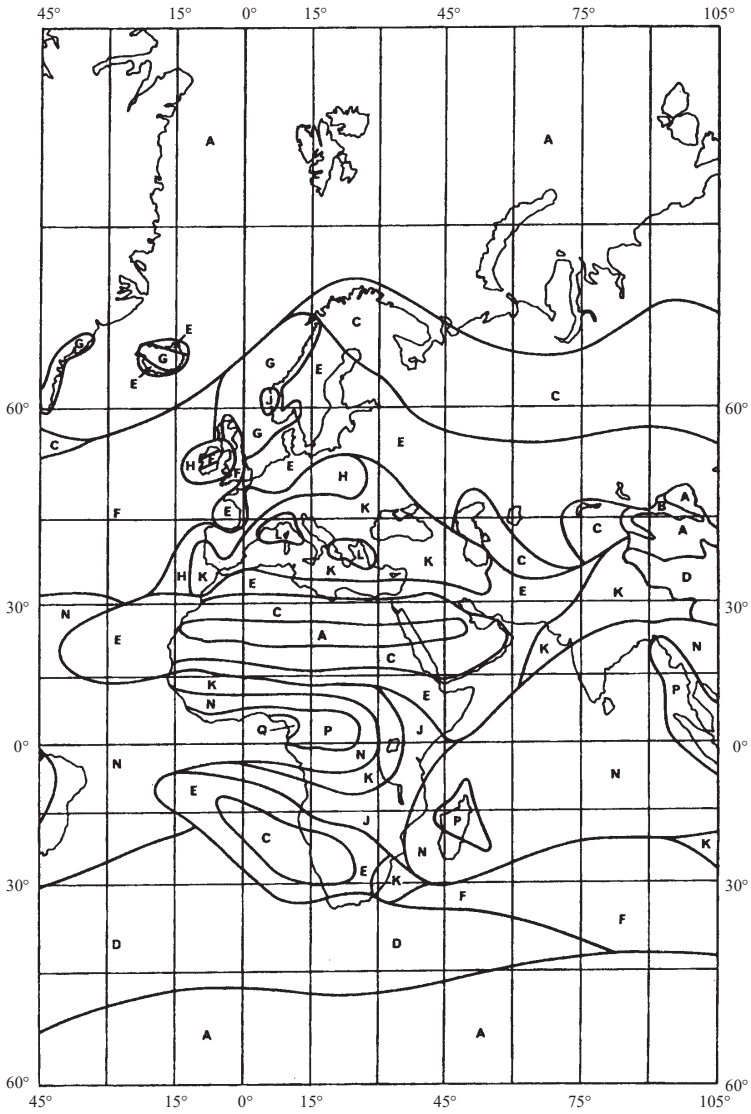

AP30AA3-01



FIGURE 2  
Rain-climatic zones (Region 2)

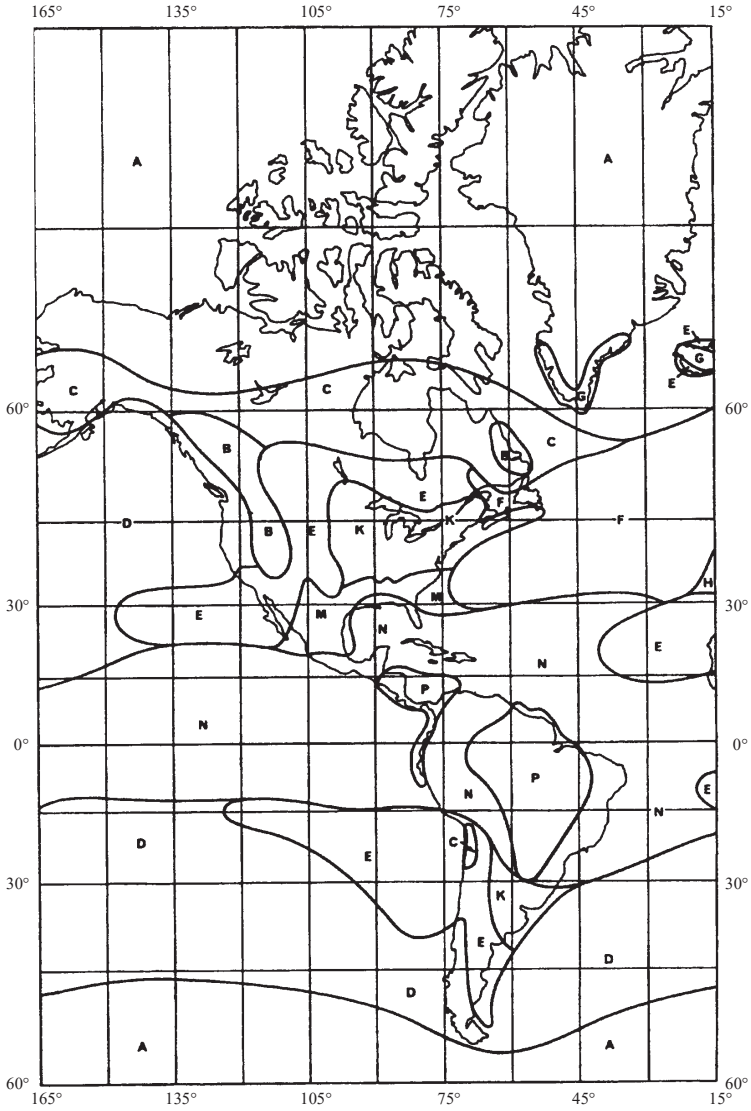

AP30AA3-02

FIGURE 3  
Rain-climatic zones for Regions 1 and 3 between  
longitudes 60° E and 150° W

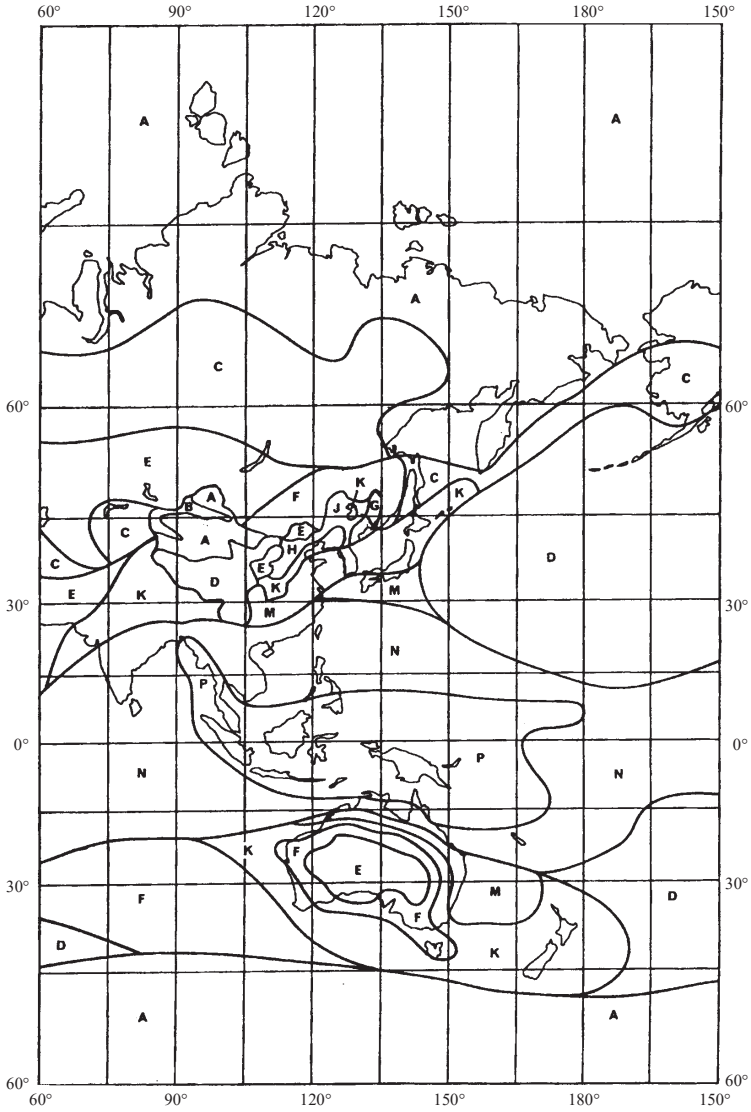
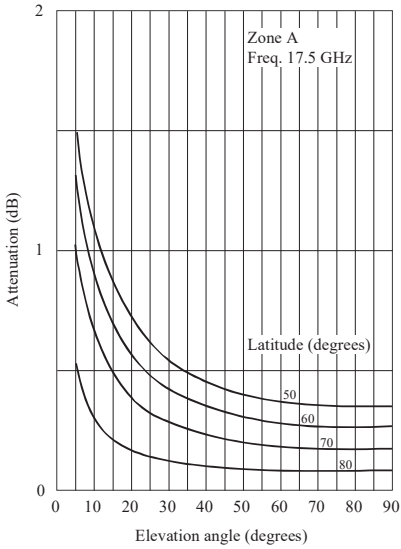
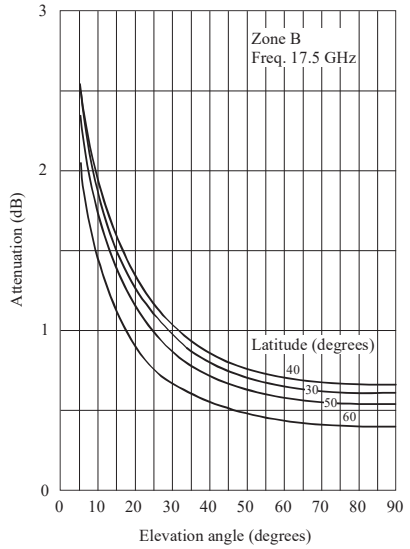

FIGURE 4

Rain attenuation values exceeded for 1% of the worst month (sea level) for Region 2 rain-climatic zones



a) Rain-climatic zone A



b) Rain-climatic zone B

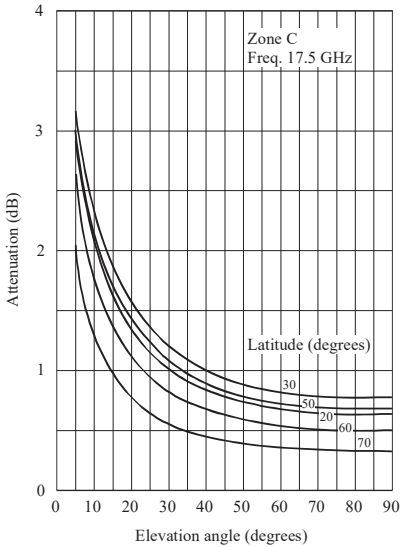

c) Rain-climatic zone C

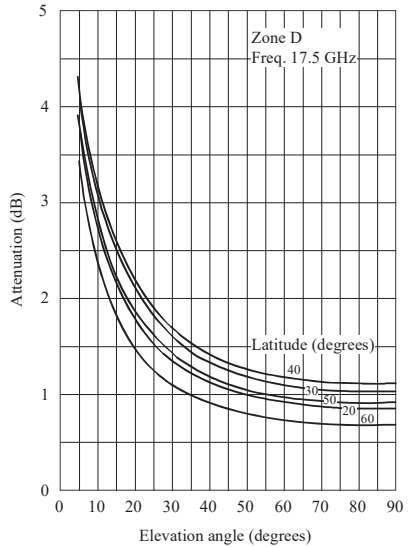

d) Rain-climatic zone D

AP30AA3-04a

FIGURE 4 (continued)

Rain attenuation values exceeded for 1% of the worst month  
(sea level) for Region 2 rain-climatic zones

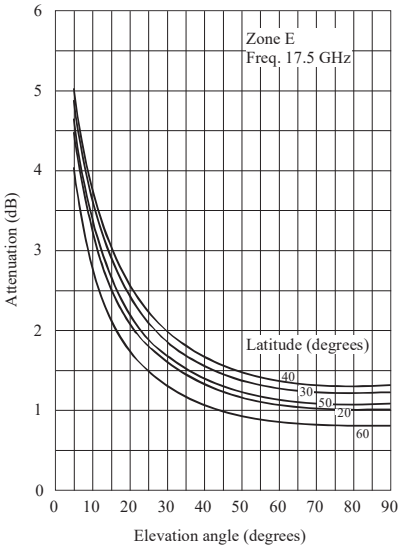

e) Rain-climatic zone E

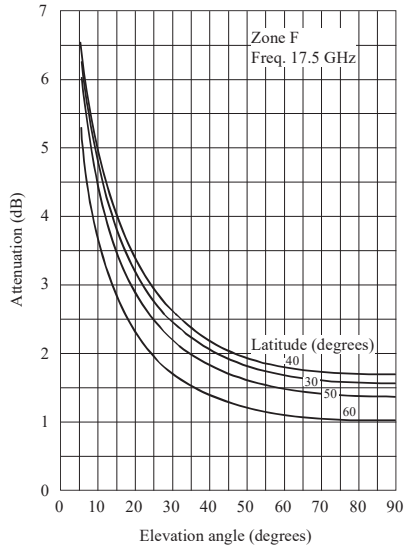

f) Rain-climatic zone F

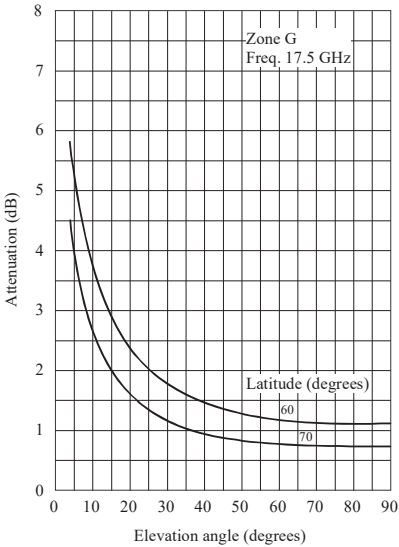

g) Rain-climatic zone G

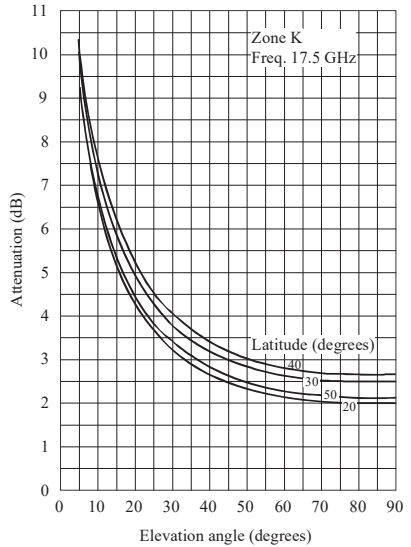

h) Rain-climatic zone K

AP30AA3-04b

FIGURE 4 (continued)

Rain attenuation values exceeded for 1% of the worst month (sea level) for Region 2 rain-climatic zones

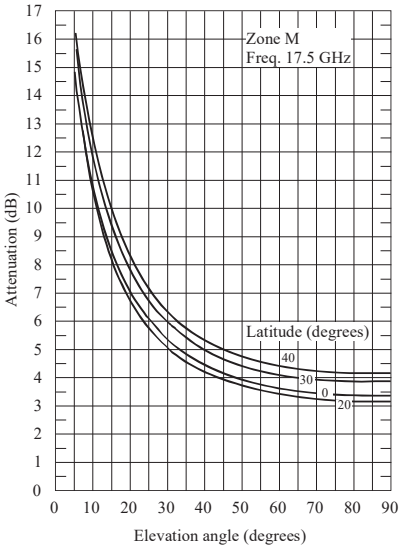

i) Rain-climatic zone M

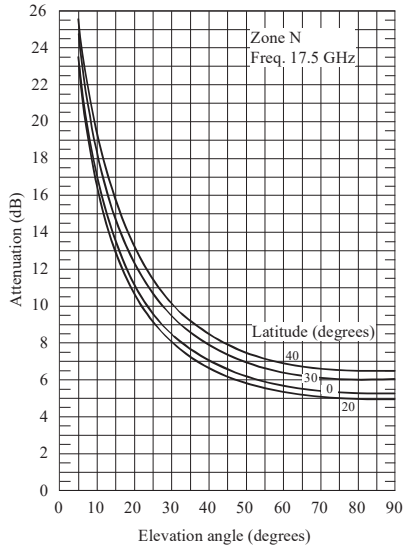

j) Rain-climatic zone N

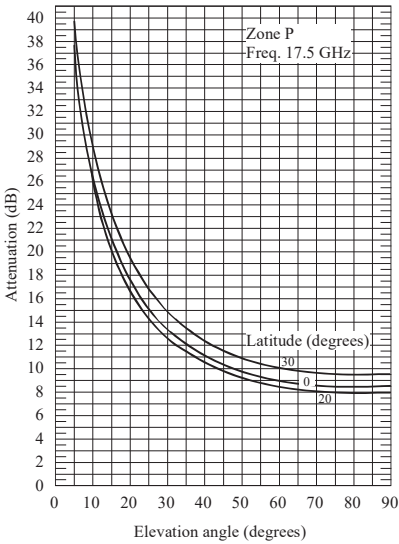

k) Rain-climatic zone P

AP30AA3-04c

## 2.5 Procedure for calculating the $C/I$ ratio at a space station receiver input

In Region 2, the calculation of the feeder-link  $C/I$  ratio (exceeded for 99% of the worst month) at a space station receiver input used to obtain the overall equivalent protection margin at a test point assumes a rain attenuation value not exceeded for 99% of the worst month on the wanted feeder-link path. For the interfering feeder-link signal path, clear sky propagation (i.e., including atmospheric absorption only) is assumed.

In Regions 1 and 3, the calculation of the feeder-link  $C/I$  ratio at a space station receiver input used to obtain the feeder-link equivalent protection margin at a test point assumes free space conditions on the wanted feeder-link path and on the interfering feeder-link path.

## 3 Basic technical characteristics for Regions 1 and 3

### 3.1 Translation frequency and guardbands

#### a) 17 GHz feeder-links

The feeder-link Plan generally uses a frequency translation of 5.6 GHz between the 17 GHz feeder-link channels and the 12 GHz downlink channels. Other values of the translation frequency may be used, provided that the corresponding channels have been assigned to the space station of the administration concerned.

With the value of frequency translation between the feeder-link frequency band (17.3-18.1 GHz in Regions 1 and 3) and the downlink frequency band (11.7-12.5 GHz in Region 1 and 11.7-12.2 GHz in Region 3), the guardbands specified in § 3.9 of Annex 5 to Appendix 30 for the downlink Plan result in corresponding guardband bandwidths of 11 MHz at the upper and 14 MHz at the lower feeder-link band edges. These feeder-link guardbands may be used to provide space operation functions in accordance with No. 1.23 in support of the operation of geostationary-satellite networks in the broadcasting-satellite service. (WRC-03)

#### b) 14 GHz feeder-links

As the maximum available bandwidth for the feeder-link band 14.5-14.8 GHz is only 300 MHz divided into fourteen 27 MHz channels, against 800 MHz (40 channels) and 500 MHz (24 channels) in the downlink Plan for Regions 1 and 3, respectively, several translation frequencies must be considered to allow any channel in the Plan to be used. Consequently, a particular feeder-link channel has been assigned to several broadcasting-satellite service Plan channels simultaneously.

Generally, the translation frequencies from the feeder-link channels are:

- 2 797.82 MHz to downlink broadcasting-satellite service channels 1 to 14;
- 2 529.30 MHz to downlink broadcasting-satellite service channels 15 to 28;
- 2 260.78 MHz to downlink broadcasting-satellite service channels 29 to 40.

The guardband bandwidths are 11.80 MHz at the lower band edge and 11.86 MHz at the upper band edge.

c) *Frequency translation rules*

Specific rules for selecting appropriate frequency translations are given in § 6.2.1.2.2 and 6.2.1.3.3 of the 1985 Conference (WARC Orb-85) Report to the 1988 Conference (WARC Orb-88). These rules permit the derivation of simple-to-use tables that define the channel translations that were avoided in revising the Regions 1 and 3 feeder-link Plan for both the 14 GHz and 17 GHz bands (see Tables 3 and 4).

TABLE 3

**14.5-14.8 GHz/11.7-12.5 GHz channel translations that should be avoided (as far as possible) according to the 1985 Conference frequency translation rules**

14 GHz feeder-link channel number	Downlink channel numbers to be avoided (as far as possible)				
1	7	8	9	19	20
2	8	9	10	20	21
3	9	10	11	21	22
4	10	11	12	22	23
5	11	12	13	23	24
6	12	13	14	24	25
7	13	14	15	25	26
8	14	15	16	26	27
9	15	16	17	27	28
10	16	17	18	28	29
11	17	18	19	29	30
12	18	19	20	30	31
13	19	20	21	31	32
14	20	21	22	32	33





### 3.2 Carrier-to-noise ratio

§ 3.3 of Annex 5 to Appendix 30 provides guidance for planning and the basis for the evaluation of the carrier-to-noise ( $C/N$ ) ratios of the feeder-link and downlink Plans.

As guidance for planning, the reduction in quality in the downlink due to thermal noise in the feeder-link is taken as equivalent to a degradation in the downlink  $C/N$  ratio of approximately 0.5 dB not exceeded for 99% of the worst month.

For downlinks, as indicated in Appendix 30, the 1977 Conference (WARC SAT-77) adopted a  $C/N$  value of 14.5 dB for 99% of the worst month at the edge of the service area. The required feeder-link  $C/N$  is 24 dB for 99% of the worst month, at the edge of the service area, to produce an overall  $C/N$  performance of 14 dB.

### 3.3 Protection ratios

For planning in Regions 1 and 3 at the 1988 Conference (WARC Orb-88), the following protection ratios were applied for the purpose of calculating the feeder-link equivalent protection margins<sup>41</sup>:

- co-channel protection ratio = 40 dB;
- adjacent channel protection ratio = 21 dB.

The method for the calculation of the feeder-link equivalent protection margin is given in § 1.7.

For revising the Regions 1 and 3 feeder-link Plan at WRC-97, the corresponding values of aggregate protection ratio that were used to calculate the feeder-link equivalent protection margins which appear in the alternative formula for overall equivalent protection margin given in § 1.12 are specified in Recommendation ITU-R BO.1297, as follows<sup>42, 43</sup>:

- co-channel protection ratio = 30 dB;
- adjacent channel protection ratio = 22 dB. (WRC-2000)

---

<sup>41</sup> These protection ratio values were used for assignments notified, which are in conformity with this Appendix, brought into use, and for which the date of bringing into use has been confirmed to the Bureau before 27 October 1997.

<sup>42</sup> These protection ratio values were used for assignments notified, which are in conformity with this Appendix, brought into use, and for which the date of bringing into use has been confirmed to the Bureau between 27 October 1997 and 12 May 2000. (WRC-2000)

<sup>43</sup> These protection ratio values were used for protection of digital and analogue assignments from analogue emissions. (WRC-2000)

However, it should be noted that the revision of the Regions 1 and 3 feeder-link Plan by WRC-97 was based on “simultaneous planning of feeder links and downlinks with calculation of overall equivalent protection margins” (as defined in § 1.11 of Annex 5 to Appendix 30 and in § 1.12) using the following values of aggregate protection ratio:

- co-channel = 23 dB;
- adjacent channel = 15 dB. (WRC-03)

It was also specified that, for the revision of the Regions 1 and 3 feeder-link Plan, no overall co-channel single entry *C/I* ratio should be lower than 28 dB. (WRC-03)

Nevertheless, for assignments notified, which are in conformity with this Appendix, brought into use, and for which the date of bringing into use has been confirmed to the Bureau before 27 October 1997, the overall equivalent protection margins were calculated using a co-channel overall protection ratio of 30 dB and lower and upper overall adjacent channel protection ratios of 14 dB.

Revision of the Regions 1 and 3 feeder-link Plan at WRC-97 and planning at WRC-2000 were generally based on a set of reference parameters such as the average e.i.r.p., the reference earth station transmitting antenna, all test points placed within the –3 dB contour, a bandwidth of 27 MHz and the predetermined value of *C/N*. The Regions 1 and 3 feeder-link Plan as established by WRC-2000 is generally based on the use of digital modulation. (WRC-2000)

WRC-2000 adopted for the protection of digital assignments from digital emissions the following protection ratio values to be applied for calculation of feeder-link equivalent protection margins of the WRC-2000 Regions 1 and 3 feeder-link Plan:

- 27 dB for co-channel signals;
- 22 dB for adjacent channel signals. (WRC-2000)

During planning at WRC-2000, these values were used for all assignments of the Regions 1 and 3 feeder-link Plan and List, except those for which WRC-2000 adopted different values to be used in the planning process<sup>44</sup>. (WRC-03)

Protection masks and associated calculation methods for interference into broadcasting-satellite systems involving digital emissions shall be in accordance with Recommendation ITU-R BO.1293-2 (Annexes 1 and 2<sup>45</sup>). (WRC-03)

---

<sup>44</sup> For analogue assignments, the protection ratios of WRC-97 (30 dB co-channel, 22 dB adjacent channel) were used. (WRC-2000)

<sup>45</sup> Annex 3 of this Recommendation may be applied only in compatibility analysis for bilateral coordination between administrations. (WRC-03)

### **3.4 Feeder-link e.i.r.p.**

The level of e.i.r.p. of each feeder link is specified in Article 9A.

The level of e.i.r.p. specified in the Plan can only be exceeded under certain conditions explained in § 3.11 of this Annex (see also Article 5, § 5.1.1).

### **3.5 Transmitting antenna**

#### **3.5.1 Antenna diameter**

The feeder-link Plan is based on an antenna diameter of 5 m for the band 17.3-18.1 GHz and 6 m for the band 14.5-14.8 GHz.

For all antenna diameters including antennas smaller than 5 m for the 17.3-18.1 GHz band and 6 m for the 14.5-14.8 GHz band, the off-axis e.i.r.p. shall not exceed the limits indicated by Curve A in Fig. A of § 3.5.3 of this Annex for assignments notified, which are in conformity with this Appendix, brought into use, and for which the date of bringing into use has been confirmed to the Bureau before 27 October 1997 and by the Curve A' of Fig. A for other assignments.

#### **3.5.2 On-axis gain**

The on-axis gain for the 5 m antenna at 17.3-18.1 GHz and for the 6 m antenna at 14.5-14.8 GHz is taken as 57 dBi.

#### **3.5.3 Off-axis e.i.r.p. of transmitting antennas**

The co-polar and cross-polar off-axis e.i.r.p. values used for the original 1988 feeder-link Plan in Regions 1 and 3 are shown by Curves A and B respectively in Fig. A<sup>46</sup>.

The corresponding off-axis e.i.r.p. values used for planning at WRC-97 are shown by Curves A' and B' in Fig. A as specified in Recommendation ITU-R BO.1295.

#### **3.5.4 Pointing accuracy**

The Plan has been developed to accommodate a loss in gain of 1 dB due to earth station antenna mispointing.

The deviation of the antenna beam from its nominal pointing direction must not exceed a limit of 0.1° in any direction. Moreover, the angular rotation of the receiving beam about its axis must not exceed a limit of ±1°; the limit on rotation is not necessary for beams of circular cross section using circular polarization.

---

<sup>46</sup> This antenna pattern is used in the revision of the Regions 1 and 3 Plan for assignments notified, which are in conformity with this Appendix, brought into use, and for which the date of bringing into use has been confirmed to the Bureau before 27 October 1997.

FIGURE A  
Earth station e.i.r.p. at off-axis antenna angles

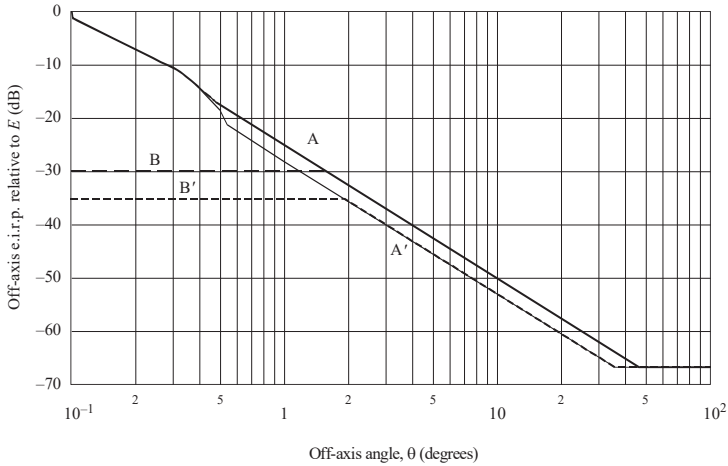

Curves A: WARC Orb-88 Regions 1 and 3 co-polar  
 A': WRC-97 co-polar  
 B: WARC Orb-88 Regions 1 and 3 cross-polar  
 B': WRC-97 cross-polar

AP30AA3-A

Co-polar component (dBW):

Curve A (WARC Orb-88)

$E$  for  $0^\circ \leq \theta \leq 0.1^\circ$   
 $E - 21 - 20 \log \theta$  for  $0.1^\circ < \theta \leq 0.32^\circ$   
 $E - 5.7 - 53.2 \theta^2$  for  $0.32^\circ < \theta \leq 0.44^\circ$   
 $E - 25 - 25 \log \theta$  for  $0.44^\circ < \theta \leq 48^\circ$   
 $E - 67$  for  $48^\circ < \theta$

Curve A' (WRC-97)

$E$  for  $0^\circ \leq \theta \leq 0.1^\circ$   
 $E - 21 - 20 \log \theta$  for  $0.1^\circ < \theta \leq 0.32^\circ$   
 $E - 5.7 - 53.2 \theta^2$  for  $0.32^\circ < \theta \leq 0.54^\circ$   
 $E - 28 - 25 \log \theta$  for  $0.54^\circ < \theta \leq 36.31^\circ$   
 $E - 67$  for  $36.31^\circ < \theta$

Cross-polar component (dBW): (WRC-03)

Curve B (WARC Orb-88)

$E - 30$  for  $0^\circ \leq \theta \leq 1.6^\circ$   
 $E - 25 - 25 \log \theta$  for  $1.6^\circ < \theta \leq 48^\circ$   
 $E - 67$  for  $48^\circ < \theta$

Curve B' (WRC-97)

$E - 35$  for  $0^\circ \leq \theta \leq 1.91^\circ$   
 $E - 28 - 25 \log \theta$  for  $1.91^\circ < \theta \leq 36.31^\circ$   
 $E - 67$  for  $36.31^\circ < \theta$

where:

$E$ : earth station e.i.r.p. on the antenna axis (dBW);

$\theta$ : off-axis angle referred to the main lobe axis (degrees).

### 3.6 Transmitter power

The maximum transmitter power delivered to the input of the antenna of the feeder-link earth station per 27 MHz television channel shall be such as to ensure that the e.i.r.p. envelope in § 3.5.3 is not exceeded except under certain conditions specified in § 3.11.

### 3.7 Satellite receiving antenna

#### 3.7.1 Cross-section of receiving antenna beam

Planning has generally been based on beams of elliptical or circular cross-section. When the assignments are implemented, or when the Plan is modified, administrations may use non-elliptical (shaped) beams as described in Annex 2.

For planning purposes at WRC-97, an antenna diameter of 5 m for the band 17.3-18.1 GHz and 6 m for the band 14.5-14.8 GHz were assumed.

The on-axis gain for the 5 m antenna at 17.3-18.1 GHz and for the 6 m antenna at 14.5-14.8 GHz is taken as 57 dBi.

If the cross-section of the receiving antenna beam is elliptical, the effective beamwidth  $\varphi_0$  is a function of the angle of rotation  $q$  between the plane containing the satellite and the major axis of the beam cross-section and the plane in which the beamwidth is required.

The relationship between the maximum gain of an antenna and the half-power beamwidth can be derived from the expression:

$$G_m = 27\,843/ab$$

where:

$a$  and  $b$  are the angles (degrees) subtended at the satellite by the major and minor axes of the elliptical cross-section of the beam. An antenna efficiency of 55% is assumed.

#### 3.7.2 Minimum beamwidth

A minimum value of  $0.6^\circ$  for the half-power beamwidth of the receiving antenna has been used for planning.

#### 3.7.3 Reference patterns

The reference patterns for the co-polar and cross-polar components of the satellite receiving antenna used for planning at the 1988 Conference (WARC Orb-88) are given by Curves A and B respectively in Fig. B<sup>47</sup>.

---

<sup>47</sup> See footnote 46.

The corresponding curves used for replanning at WRC-97 are given by Curves A' and B' in Fig. B, as specified in Recommendation ITU-R BO.1296.

FIGURE B  
 Receiving space station circularly polarized antenna co-polar and cross-polar reference patterns for elliptical beams for planning in Regions 1 and 3

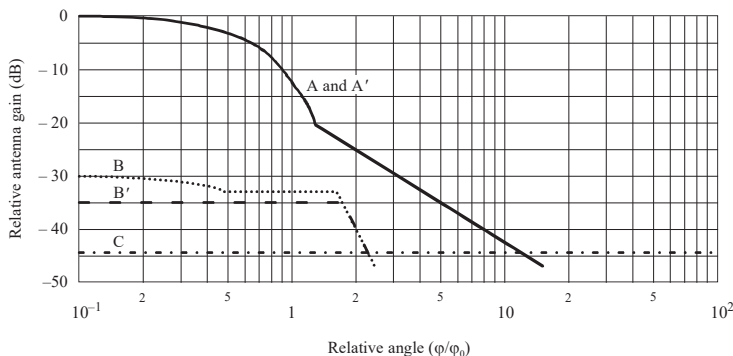

Curves A and A': WARC Orb-88 and WRC-97 co-polar  
 B: WARC Orb-88 cross-polar  
 B': WRC-97 cross-polar  
 C: Curve C (minus the on-axis gain)

AP30AA3-B

Co-polar relative gain (dB):

Curve A (WARC Orb-88) and Curve A' (WRC-97):

$$G = -12 (\varphi/\varphi_0)^2 \quad \text{for } 0 \leq \varphi/\varphi_0 < 1.3$$

$$G = -17.5 - 25 \log (\varphi/\varphi_0) \quad \text{for } 1.3 \leq \varphi/\varphi_0$$

After intersection with Curve C, as Curve C

Cross-polar relative gain (dB):

Curve B (WARC Orb-88)

$$G = -30 - 12 (\varphi/\varphi_0)^2 \quad \text{for } 0 \leq \varphi/\varphi_0 \leq 0.5$$

$$G = -33 \quad \text{for } 0.5 < \varphi/\varphi_0 \leq 1.67$$

$$G = -40 - 40 \log \left( \frac{\varphi}{\varphi_0} - 1 \right) \quad \text{for } 1.67 \leq \varphi/\varphi_0$$

After intersection with Curve C, as Curve C

Curve B' (WRC-97)

$$G = -35 \quad \text{for } 0 \leq \varphi/\varphi_0 < 1.75$$

$$G = -40 - 40 \log \left( \frac{\varphi}{\varphi_0} - 1 \right) \quad \text{for } 1.75 \leq \varphi/\varphi_0$$

After intersection with Curve C, as Curve C

Curve C: minus the on-axis gain (Curve C in the above Figure illustrates the particular case of an antenna with an on-axis gain of 44.44 dB)

where:

φ: off-axis angle (degrees)

φ₀: cross-sectional half-power beamwidth in the direction of interest (degrees).

The relationship between the maximum gain of an antenna and the half-power beamwidth can be derived from the expression in § 3.7.1.

In some cases, to reduce co-polar interference, the pattern shown in Fig. C is used; this use is indicated in the Plan by note 1. This pattern is derived from an antenna producing an elliptical beam with fast roll-off in the main lobe assuming a “beamlet” beamwidth of  $0.6^\circ$ . Three curves for different values of  $\varphi_0$  are shown as examples.

FIGURE C  
Reference patterns for co-polar and cross-polar components for satellite receiving antennas with fast roll-off in the main beam for Regions 1 and 3

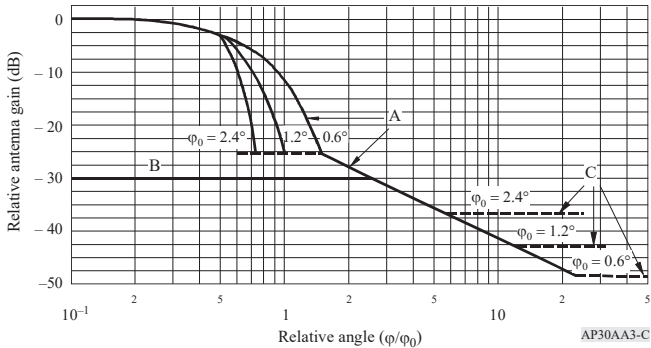

Curve A: co-polar component (dB relative to main beam gain)

$$\begin{aligned}
 & -12 (\varphi/\varphi_0)^2 && \text{for} && 0 \leq \varphi/\varphi_0 \leq 0.5 \\
 & -33.33 \varphi_0^2 \left( \frac{\varphi}{\varphi_0} - x \right)^2 && \text{for} && 0.5 < \varphi/\varphi_0 \leq \frac{0.87}{\varphi_0} + x \\
 & -25.23 && \text{for} && \frac{0.87}{\varphi_0} + x < \varphi/\varphi_0 \leq 1.45 \\
 & -(22 + 20 \log (\varphi/\varphi_0)) && \text{for} && \varphi/\varphi_0 > 1.45
 \end{aligned}$$

after intersection with Curve C, as Curve C.

Curve B: cross-polar component (dB relative to main beam gain)

$$-30 \quad \text{for} \quad 0 \leq \varphi/\varphi_0 < 2.51$$

after intersection with Curve A, as Curve A.

Curve C: minus the on-axis gain (curves A and C represent examples for three antennas having different values of  $\varphi_0$  as labelled in Fig. C. The on-axis gains of these antennas are 37, 43 and 49 dBi, respectively),

where:

$\varphi$ : off-axis angle (degrees);

$\varphi_0$ : dimension of the minimum ellipse fitted around the feeder-link service area in the direction of interest (degrees);

$$x = 0.5 \left( 1 - \frac{0.6}{\varphi_0} \right)$$

### 3.7.4 Pointing accuracy

The deviation of the receiving antenna beam from its nominal pointing direction must not exceed  $0.1^\circ$  in any direction. Moreover, the angular rotation of the receiving beam about its axis must not exceed  $\pm 1^\circ$ ; this limit is not necessary for beams of circular cross-section using circular polarization.

### 3.7.5 Composite beam (WRC-2000)

A composite beam represents a single beam (i.e. “simulated shaped beam”) and is formed by combining two or more elliptical beams at a given orbital position. In general, composite beams were used at WRC-2000 for administrations which had more than one beam at a given orbital position in the WRC-97 Regions 1 and 3 feeder-link Plan. (WRC-2000)

### 3.8 System noise temperature

The satellite system noise temperature values generally used in the Plan at the 1988 Conference (WARC Orb-88) are 1 800 K for 17 GHz and 1 500 K for 14 GHz<sup>48</sup>. For revising the Regions 1 and 3 Plan at WRC-97 these values are 900 K for 17 GHz and 750 K for 14 GHz. A value of 600 K was used for the 17 GHz band in the revision of the Regions 1 and 3 Plan at WRC-2000. WRC-2000 did not change the value for the 14 GHz band. (WRC-03)

### 3.9 Polarization

In Regions 1 and 3, circular polarization was normally used for the purpose of planning the feeder-links.

For the definitions of the terms “direct and indirect polarization”, see § 3.2.3 of Annex 5 to Appendix 30.

For the planning of the broadcasting-satellite service, circular polarization is generally used. However, for implementation of assignments in the Regions 1 and 3 Plan, linear polarization may also be used subject to successful application of the modification procedure of Article 4. Linear polarization is defined in Recommendation ITU-R BO.1212. This Recommendation should be used when analysing linearly polarized signals.

---

<sup>48</sup> These system temperature values are still used for assignments notified, which are in conformity with this Appendix, brought into use, and for which the date of bringing into use has been confirmed to the Bureau before 27 October 1997.



### 3.10 Automatic gain control

The downlink Plan was based on constant satellite output power. However, the feeder-link Plan does not take account of the effect of automatic gain control on board satellites. Up to 15 dB of automatic gain control is permitted, subject to no increase in interference to other satellite systems.

### 3.11 Power control

In Regions 1 and 3, a permitted increase which may be used to overcome rain fading for each assignment is included in the Plan.

In the calculation, in cases where satellites do not use common or adjacent channels cross-polarized to each other, the maximum permissible e.i.r.p. increase, which must not exceed 10 dB, corresponds to the amount of rain attenuation which occurs on the interfering feeder link.

#### 3.11.1 Method for determination of the increase in e.i.r.p. during rain attenuation for an assignment over the Plan value

*Condition to be observed*

The increase in e.i.r.p. of the assignment studied must not entail an impairment of more than 0.5 dB of the feeder-link equivalent protection margin of any other assignment of any other administration.

*Calculation method*

*Step 1:* compile a list of all assignments of other administrations (A, B, C, . . .) in the same orbital position and positions within  $\pm 6^\circ$  (or further if no station is found within  $6^\circ$  arc) liable to suffer interference from the assignment studied.

*Step 2:* calculate the feeder-link equivalent protection margin of assignment A in free-space conditions, taking account of all interference sources affecting A at the worst test points, namely:

- for assignment A: the point corresponding to the minimum *C/N* ratio;
- for each interference source affecting A: the point corresponding to the maximum interference power affecting A.

*Step 3:* introduce for the assignment studied the rain attenuation for 0.1% of the worst month and the corresponding rain depolarization value.

*Step 4:* recalculate the feeder-link equivalent protection margin of assignment A at the worst test points, namely:

- for assignment A: the test point used in Step 2 above;
- for the assignment studied: the test point corresponding to the maximum interference power affecting A.

At this stage, the e.i.r.p. of the assignment studied is that contained in the Plan.

*Step 5:* increase the e.i.r.p. of the assignment studied by 0.1 dB and recalculate the equivalent uplink margin of A as in Step 4 above.

*Step 6:* repeat the operation of Step 5 above until the equivalent uplink margin of assignment A is impaired by more than 0.5 dB in relation to the value found under Step 2 above, or until the e.i.r.p. increase exceeds 10 dB or the rain attenuation (see Step 3). Adopt the e.i.r.p. increase in the preceding iteration step.

*Step 7:* repeat the operations in Step 2 to Step 6 above, considering the assignments B, C, . . .

*Step 8:* adopt the smallest of the increases in e.i.r.p. found under Step 6 above for the various assignments A, B, C, . . .

### **3.11.2 Propagation model**

For the calculation of rain attenuation for 0.1% of the worst month, the model described in § 2.2 should be used. It shall be assumed that the 0.1% value is 3.3 times the 1% value (dB).

Rain depolarization shall be calculated on the basis of attenuation, using the method described in § 2.4.

**3.11.3 Variation of power with rain attenuation**

The instantaneous increase in power to overcome rain attenuation must not exceed the bounds given by the characteristics shown in Fig. 5.

FIGURE 5  
Characteristic for up-link power control

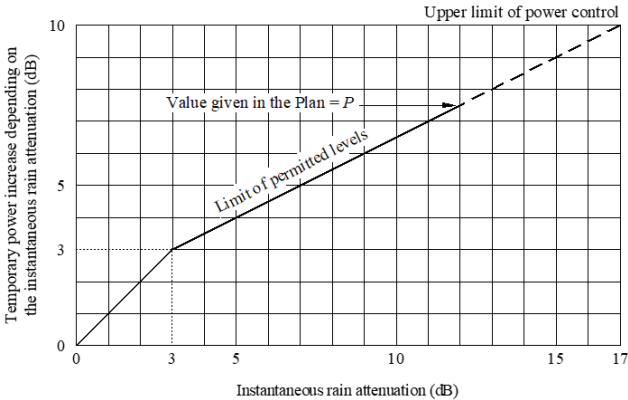

*P*: value of permitted increase given in the Plan, or calculated by the BR, which varies for each assignment. The upper limit of this value is 10 dB.

AP30AA3-05

**3.11.4 Procedures**

An administration wishing to introduce power control may use a value not exceeding that given in Article 9A or it may request, where this is possible, the use of a higher value for a given earth station location. In this latter case, it shall request the Bureau to calculate the maximum permissible value for that site. The administration shall provide the Bureau with the coordinates of the station, the proposed antenna characteristics, including the off-axis co-polar and cross-polar characteristics, and the rain climatic zone.

The Bureau shall calculate the permissible increase in power using the method described in § 3.11.1.

The Bureau shall communicate the results of the calculations to the requesting administrations as well as to those administrations whose feeder-link equivalent protection margin is reduced.

In any case, the permitted increase in e.i.r.p. above that given in the Plan shall not exceed 10 dB.

In the event of modifications to the Plan, the Bureau shall recalculate the value of power control for the assignment subject to the modification and insert the appropriate value for that assignment in the Plan. A modification to the Plan shall not require the adjustment of the values of permissible power increase of other assignments in the Plan.

**3.12** (SUP - WRC-97)**3.13 Depolarization compensation**

The Plan is developed without the use of depolarization compensation. Depolarization compensation is permitted only to the extent that interference to other satellites does not increase by more than 0.5 dB<sup>49</sup> relative to that calculated in the feeder-link Plan.

**3.14 Amplitude-modulation to phase-modulation conversion**

The degradation caused by AM to PM conversion was taken into account when calculating the carrier-to-noise ratio of the feeder link. A value of 2.0 dB was allowed.

**3.15 Orbit positions**

The Plan is generally based on the use of a regular spacing of 6°. The orbital positions are those given in the Plan. (WRC-03)

**3.16 Satellite station-keeping**

Space stations in the broadcasting-satellite service must be maintained in position with an accuracy equal to or better than  $\pm 0.1^\circ$  in the E-W direction. For such space stations, the maintenance of the tolerance  $\pm 0.1^\circ$  in the N-S direction is recommended but is not a requirement.

**3.17 Orbital separation limit for interference calculation** (WRC-2000)

WRC-2000 has adopted the use of an orbital separation limit for interference calculation in Regions 1 and 3. Beyond this limit no interference was taken into account. (WRC-2000)

Initially, the values used for the orbital separation limit were 15° for co-polar and 9° for cross-polar emissions. At a later stage, the unique value of the orbital separation limit of 9° was adopted by WRC-2000. (WRC-2000)

---

<sup>49</sup> This margin has to be shared between power control effects and depolarization compensation effects when both are involved (see § 3.11).

## 4 Basic technical characteristics for Region 2

### 4.1 Translation frequency and guard bands

The feeder-link Plan is based on the use of a single frequency translation of 5.1 GHz between the 17 GHz feeder-link channels and the 12 GHz downlink channels. Other values of the translation frequency may be used, provided that the corresponding channels have been assigned to the space station of the administration concerned.

With a single value frequency translation between the feeder-link frequency band (17.3-17.8 GHz) and the downlink frequency band (12.2-12.7 GHz), the guard bands present in the downlink Plan result in corresponding bandwidths of 12 MHz at the upper and lower feeder-link band edges. These feeder-link guard bands may be used to provide space operation functions in accordance with No. 1.23 in support of the operation of geostationary-satellite networks in the broadcasting-satellite service. (WRC-03)

### 4.2 Carrier-to-noise ratio

Section 3.3 of Annex 5 to Appendix 30 provides guidance for planning and the basis for the evaluation of the carrier-to-noise ratios of the feeder-link and downlink Plans.

As a guidance for planning, the reduction in quality in the downlink due to thermal noise in the feeder link is taken as equivalent to a degradation in the downlink carrier-to-noise ratio of approximately 0.5 dB not exceeded for 99% of the worst month.

### 4.3 Carrier-to-noise ratio

Section 3.4 of Annex 5 to Appendix 30 provides guidance for planning for the contribution of the feeder-link co-channel interference to the overall co-channel carrier-to-interference ratio. However, the feeder-link and downlink Plans are evaluated on the overall equivalent protection margin which includes the combined downlink and feeder-link contributions. Definitions given in § 1.7, 1.8, 1.9, 1.10 and 1.11 of this Annex and the protection ratios given in Section 3.4 of Annex 5 to Appendix 30 are used in the analysis of the Plans.

For the adjacent channels, the Plan is based on an orbital separation of  $0.4^\circ$  between nominally co-located satellites having cross-polarized adjacent channel assignments.

For the second adjacent channels, the Plan is based on a 10 dB improvement on the feeder-link carrier-to-interference ratio due to the satellite receive filtering.

## 4.4 Transmitting antenna

### 4.4.1 Antenna diameter

The feeder-link Plan is based on an antenna diameter of 5 m.

The minimum antenna diameter permitted in the Plan is 2.5 m. However, the feeder-link carrier-to-noise ratio and carrier-to-interference ratio resulting from the use of antennas with diameters smaller than 5 m would generally be less than those calculated in the Plan.

The use of antennas larger than 5 m, with corresponding values of on-axis e.i.r.p. higher than the planned value (indicated in § 4.4.3) but without augmented off-axis e.i.r.p., is permitted if the orbital separation between the assigned orbital location of the administration and the assigned orbital location of any other administration is greater than  $0.5^\circ$ .

Antennas with diameters larger than 5 m can also be implemented if the above orbital separation is less than  $0.5^\circ$  and if the e.i.r.p. of the desired feeder-link earth station does not exceed the planned value of e.i.r.p.

If the above orbital separation is less than  $0.5^\circ$  and if the e.i.r.p. of the desired feeder-link earth station exceeds the planned value, agreement between administrations is required.

### 4.4.2 Transmitting antenna reference patterns (WRC-03)

The co-polar and cross-polar reference patterns of transmitting antennas used for planning in Region 2 are given in Fig. 6.

### 4.4.3 Antenna efficiency

The Plan is based on an antenna efficiency of 65%. The corresponding on-axis gain for an antenna having a 5 m diameter is 57.4 dBi at 17.55 GHz, and the corresponding value of e.i.r.p. used for planning purposes is 87.4 dBW.

### 4.4.4 Pointing accuracy

The Plan has been developed to accommodate a loss in gain due to earth station antenna mis-pointing of 1 dB. Under no circumstances shall the Plan allow for a mis-pointing angle greater than  $0.1^\circ$ .

FIGURE 6  
Reference patterns for co-polar and cross-polar components  
for transmitting antennas for Region 2

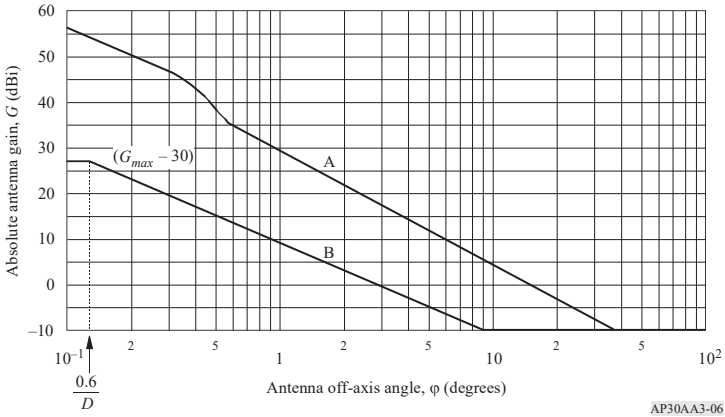

AP30AA3-06

Curve A: co-polar component (dBi)

$$G_{co} = G_{max} \quad \text{for} \quad 0^\circ \leq \phi < 0.1^\circ$$

$$G_{co} = 36 - 20 \log \phi \quad \text{for} \quad 0.1^\circ \leq \phi < 0.32^\circ$$

$$G_{co} = 51.3 - 53.2 \phi^2 \quad \text{for} \quad 0.32^\circ \leq \phi < 0.54^\circ$$

$$G_{co} = \max(29 - 25 \log \phi, -10) \quad \text{for} \quad 0.54^\circ \leq \phi \leq 180^\circ$$

$$\text{If } G_{co} > G_{max}: G_{co} = G_{max} \quad \text{(WRC-03)}$$

Curve B: cross-polar component (dBi)

$$G_{cross} = G_{max} - 30 \quad \text{for} \quad 0^\circ \leq \phi < (0.6/D)^\circ$$

$$G_{cross} = \max(9 - 20 \log \phi, -10) \quad \text{for} \quad (0.6/D)^\circ \leq \phi \leq 180^\circ$$

$$\text{If } G_{cross} > G_{max} - 30: G_{cross} = G_{max} - 30 \quad \text{(WRC-03)}$$

where:

$\phi$  : off-axis angle referred to the main-lobe axis (degrees)

$G_{max}$  : on-axis co-polar gain of the antenna (dBi)

$D$  : diameter of the antenna (m) ( $D \geq 2.5$ ).

NOTE 1 – In the angular range between  $0.1^\circ$  and  $0.54^\circ$ , the co-polar gain must not exceed the reference pattern.

NOTE 2 – In the angular range between  $0^\circ$  and  $(0.6/D)^\circ$ , the cross polar gain must not exceed the reference pattern.

NOTE 3 – At the larger off-axis angles and for 90% of all side-lobe peaks in each of the reference angular windows, the gain must not exceed the reference pattern. The reference angular windows are  $0.54^\circ$  to  $1^\circ$ ,  $1^\circ$  to  $2^\circ$ ,  $2^\circ$  to  $4^\circ$ ,  $4^\circ$  to  $7^\circ$ ,  $7^\circ$  to  $10^\circ$ ,  $10^\circ$  to  $20^\circ$ ,  $20^\circ$  to  $40^\circ$ ,  $40^\circ$  to  $70^\circ$ ,  $70^\circ$  to  $100^\circ$  and  $100^\circ$  to  $180^\circ$ . The first reference angular window for evaluating the cross-polar component should be  $(0.6/D)^\circ$  to  $1^\circ$ .

## 4.5 Transmit power

The maximum transmit power delivered to the input of the antenna of the feeder-link earth station is 1 000 W per 24 MHz television channel. This level of power can only be exceeded under certain conditions specified in § 4.10.

## 4.6 Receiving antenna

### 4.6.1 Cross-section of receiving antenna beam

Planning has been based on beams of elliptical or circular cross-section. When the assignments are implemented, or when the Plan is modified, administrations may use non-elliptical or shaped beams.

If the cross-section of the receiving antenna beam is elliptical, the effective beamwidth  $\varphi_0$  is a function of the angle of rotation  $q$  between the plane containing the satellite and the major axis of the beam cross-section and the plane in which the beamwidth is required.

The relationship between the maximum gain of an antenna and the half-power beamwidth can be derived from the expression:

$$G_m = 27843/ab$$

or

$$G_m \text{ (dB)} = 44.44 - 10 \log a - 10 \log b$$

where:

$a$  and  $b$  are the angles (degrees) subtended at the satellite by the major and minor axes of the elliptical cross-section of the beam.

An antenna efficiency of 55% is assumed.

### 4.6.2 Minimum beamwidth

A minimum value of  $0.6^\circ$  for the half-power beamwidth of the receiving antenna has been agreed on for planning.

### 4.6.3 Receiving antenna reference patterns (WRC-03)

The reference patterns for the co-polar and cross-polar components of the satellite receiving antenna used in preparing the Plan are given in Fig. 7.

Where it was necessary to reduce interference, the pattern shown in Fig. 8 was used; this use will be indicated in the Plan by an appropriate symbol. This pattern is derived from an antenna producing an elliptical beam with fast roll-off in the main lobe. Three curves for different values of  $\varphi_0$  are shown as examples.



FIGURE 7  
Reference patterns for co-polar and cross-polar components  
for satellite receiving antenna in Region 2

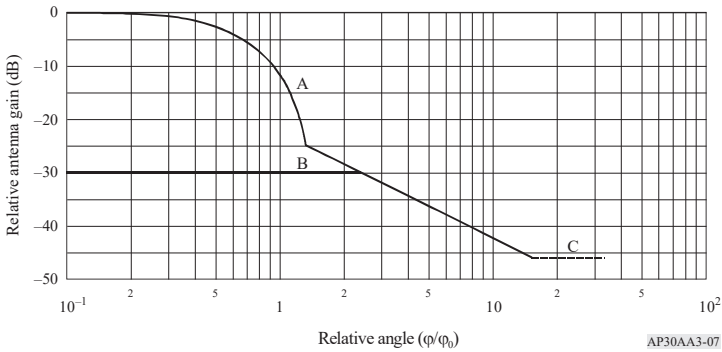

Curve A: co-polar component (dB relative to main beam gain)

$$\begin{aligned}
 & -12 (\varphi/\varphi_0)^2 && \text{for } 0 \leq (\varphi/\varphi_0) \leq 1.45 \\
 & -(22 + 20 \log (\varphi/\varphi_0)) && \text{for } (\varphi/\varphi_0) > 1.45
 \end{aligned}$$

after intersection with Curve C, as Curve C.

Curve B: cross-polar component (dB relative to main beam gain)

$$-30 \quad \text{for } 0 \leq (\varphi/\varphi_0) \leq 2.51$$

after intersection with Curve A, as Curve A.

Curve C: minus the on-axis gain (Curve C in this Figure illustrates the particular case of an antenna with an on-axis gain of 46 dBi)

FIGURE 8  
Reference patterns for co-polar and cross-polar components for satellite receiving  
antennas with fast roll-off in the main beam for Region 2

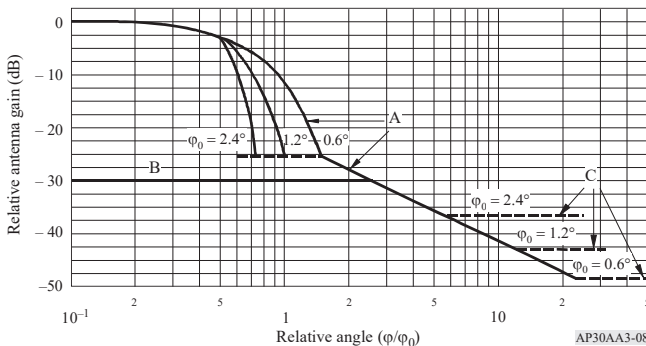

Curve A: co-polar component (dB relative to main beam gain)

$$\begin{aligned}
 & -12 (\varphi/\varphi_0)^2 && \text{for } 0 && \leq \varphi/\varphi_0 \leq 0.5 \\
 & -33.33 \varphi_0^2 (\varphi/\varphi_0 - x)^2 && \text{for } 0.5 && < \varphi/\varphi_0 \leq \frac{0.87}{\varphi_0} + x \\
 & -25.23 && \text{for } \frac{0.87}{\varphi_0} + x && < \varphi/\varphi_0 \leq 1.45 \\
 & -(22 + 20 \log (\varphi/\varphi_0)) && \text{for } && \varphi/\varphi_0 > 1.45
 \end{aligned}$$

after intersection with Curve C, as Curve C. (WRC-03)

Curve B: cross-polar component (dB relative to main beam gain)

$$-30 \quad \text{for } 0 \leq (\varphi/\varphi_0) \leq 2.51$$

after intersection with Curve A, as Curve A.

Curve C: minus the on-axis gain (Curves A and C represent examples for three antennas having different values of  $\varphi_0$  as labelled in Fig. 8. The on-axis gains of these antennas are 37, 43 and 49 dBi, respectively).

where:

$\varphi$  : off-axis angle (degrees)

$\varphi_0$  : dimension of the minimum ellipse fitted around the feeder-link service area in the direction of interest (degrees)

$$x = 0.5 \left( 1 - \frac{0.6}{\varphi_0} \right)$$

#### 4.6.4 Pointing accuracy

The deviation of the receiving antenna beam from its nominal pointing direction must not exceed 0.1° in any direction. Moreover, the angular rotation of the receiving beam about its axis must not exceed ±1°; this latter limit is not necessary for beams of circular cross-section using circular polarization.

#### 4.7 System noise temperature

The Plan is based on a value of 1 500 K for the satellite system noise temperature. WRC-03 decided that for feeder-link assignments in the Plan which have not been subsequently modified through successful application of Article 4, a value of 600 K (instead of 1 500 K) is used in application of § 5 of Annex 1 and § 1 of Annex 4. For those assignments which have been subsequently modified, the noise temperature value provided in that modification is used. (WRC-03)

#### 4.8 Polarization

4.8.1 In Region 2, for the purpose of planning the feeder links, circular polarization is used.

4.8.2 In the cases where there are polarization constraints, use of polarization other than circular is permitted only upon agreement of administrations that may be affected.

**4.9 Automatic gain control**

4.9.1 The Plan is based on the use of automatic gain control on board satellites to maintain a constant signal level at the satellite transponder output.

4.9.2 The dynamic range of automatic gain control is limited to 15 dB when satellites are located within 0.4° of each other and operate on cross-polarized adjacent channels serving common or adjacent feeder-link service areas.

4.9.3 The 15 dB limit of automatic gain control does not apply to satellites other than those specified in § 4.9.2 above.

**4.10 Power control**

The Plan has been developed without the use of power control.

The use of transmit power levels higher than those given in § 4.5 is permitted only when rain attenuation exceeds 5 dB at 17 GHz. In such cases, the transmit power may be increased by the amount that the instantaneous rain attenuation exceeds 5 dB at 17 GHz up to the limit given in Table 5.

TABLE 5

**Transmit radio frequency power (delivered to the input of the feeder-link earth station antenna) permitted in excess of 1 000 W as a function of elevation angle**

Elevation angle of feeder-link earth station antenna (degrees)	Transmit power permitted in excess of 1 000 W (dB)
0 to 40	0
40 to 50	2
50 to 60	3
60 to 90	5

**4.11 Site diversity**

Site diversity refers to the alternate use during rain of two or more transmitting earth stations which may be separated by sufficient distance to ensure uncorrelated rainfall conditions.

The use of site diversity is permitted and is considered to be an effective technique for maintaining high carrier-to-noise ratio and carrier-to-interference ratio during periods of moderate to severe rain attenuation. However, the Plan is not based on the use of site diversity.

#### **4.12 Depolarization compensation**

The Plan is developed without the use of depolarization compensation. Depolarization compensation is permitted only to the extent that interference to other satellites does not increase by more than 0.5 dB relative to that calculated in the feeder-link Plan.

#### **4.13 Minimum separation between satellites**

Figure 9 illustrates two adjacent clusters of satellites separated by  $0.9^\circ$  between the centres of the clusters. A  $\eta$  identifies a satellite of administration  $\eta$ . A cluster is formed by two or more satellites separated by  $0.4^\circ$  and located at two nominal orbital positions as specified in the Plan; one position for right-hand polarized channels and the other position for left-hand polarized channels.

##### **4.13.1 Satellites of the same cluster**

The Plan is based on an orbital separation of  $0.4^\circ$  between satellites having cross-polarized adjacent channels (i.e. satellites located at  $+0.2^\circ$  and  $-0.2^\circ$  from the centre of the cluster). However, satellites within a cluster may be located at any orbital position within the cluster, requiring only the agreement of the other administrations having satellites sharing the same cluster. Such orbital positioning of satellites within a cluster is illustrated in Fig. 9 by some of the satellites A5, A6 and A7.

The station-keeping tolerance of  $\pm 0.1^\circ$  indicated in § 3.11 of Annex 5 to Appendix 30 must be applied to satellites located at any position within the  $0.4^\circ$  wide cluster.

##### **4.13.2 Satellites of different clusters**

In the Plan, the orbital separation between the centres of adjacent clusters of satellites is at least  $0.9^\circ$ . The value of  $0.9^\circ$  is also the minimum orbital separation to provide flexibility in the implementation of feeder links indicated in § 4.4.1 without the need for an agreement (see § 4.13.1).

FIGURE 9  
Exploded view of geostationary satellite orbit

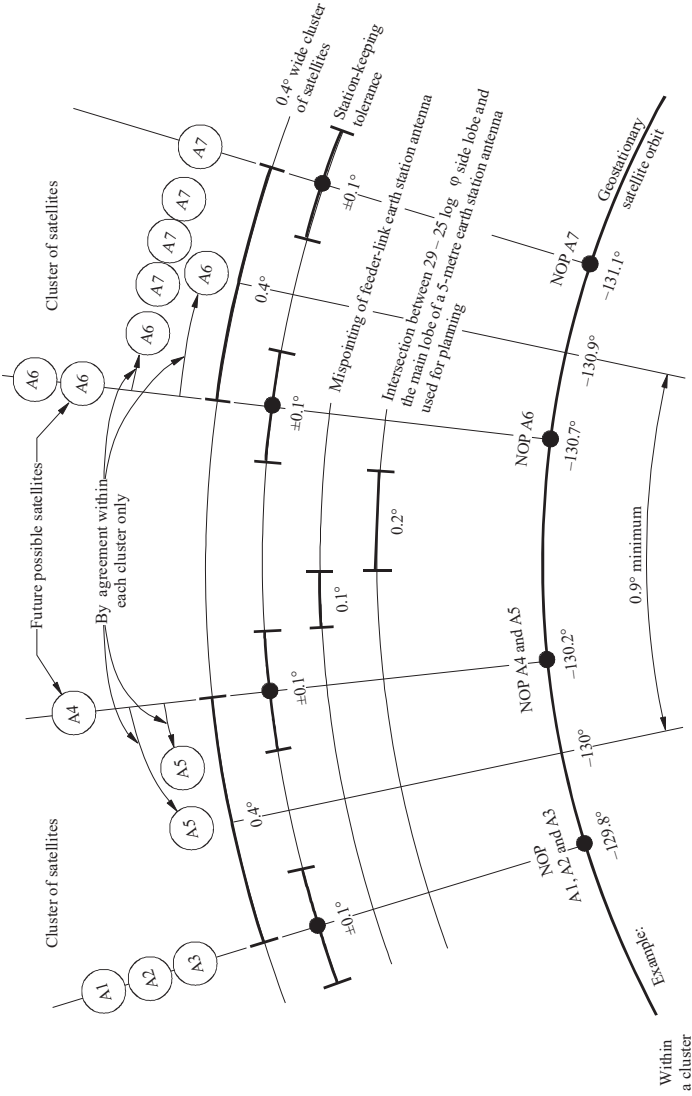

An: specific Administration  
 NOP 1: nominal orbital position, right-hand polarization  
 NOP 2: nominal orbital position, left-hand polarization

## ANNEX 4 (REV.WRC-19)

**Criteria for sharing between services**

- 1 Threshold values for determining when coordination is required between, on one hand, transmitting space stations in the fixed-satellite service or the broadcasting-satellite service and, on the other hand, a receiving space station in the feeder-link Plan or List or a proposed new or modified receiving space station in the List, in the frequency bands 17.3-18.1 GHz (Regions 1 and 3) and in the feeder-link Plan or a proposed modification to the Plan in the frequency band 17.3-17.8 GHz (Region 2)** (WRC-03)

With respect to § 7.1, Article 7, coordination of a transmitting space station in the fixed-satellite service or in the broadcasting-satellite service with a receiving space station in a broadcasting-satellite service feeder link in the Regions 1 and 3 feeder-link Plan or List, or a proposed new or modified receiving space station in the List, or in the Region 2 feeder-link Plan or proposed modification to the Plan is required when the power flux-density arriving at the receiving space station of a broadcasting-satellite service feeder link of another administration would cause an increase in the noise temperature of the feeder-link space station which exceeds a threshold value of  $\Delta T_s/T_s$  corresponding to 6%.  $\Delta T_s/T_s$  is calculated in accordance with Case II of the method given in Appendix 8. (WRC-03)

- 2 Threshold values for determining when coordination is required between transmitting feeder-link earth stations in the fixed-satellite service in Region 2 and a receiving space station in the Regions 1 and 3 feeder-link Plan or List or a proposed new or modified receiving space station in the List, in the frequency bands 14.5-14.8 GHz and 17.8-18.1 GHz** (WRC-19)

With respect to § 7.1, Article 7, coordination of a transmitting feeder-link earth station in the fixed-satellite service with a receiving space station in a broadcasting-satellite feeder link in the Regions 1 and 3 feeder-link Plan or List, or a proposed new or modified receiving space station in the List, is required when the power flux density arriving at the receiving space station of a broadcasting-satellite service feeder link of another administration would cause an increase in the noise temperature of the feeder-link space station which exceeds a threshold value of  $\Delta T/T$  corresponding to 6%, where  $\Delta T/T$  is calculated in accordance with the method given in Appendix 8. (WRC-19)

**3 Threshold values for determining when coordination is required between transmitting earth stations in the fixed-satellite service in the frequency band 14.5-14.75 GHz (in countries listed in Resolution 163 (WRC-15)) and 14.5-14.8 GHz (in countries listed in Resolution 164 (WRC-15)) not for feeder links for the broadcasting-satellite service and a receiving space station subject to a Plan in the frequency band 14.5-14.8 GHz (WRC-15)**

With respect to § 7.1, Article 7, coordination of a transmitting earth station in the fixed-satellite service with a receiving space station in a broadcasting-satellite feeder link in the Regions 1 and 3 feeder-link Plan or List, or a proposed new or modified receiving space station in the List, is required when the power flux-density arriving at the receiving space station of a broadcasting-satellite service feeder link of another administration exceeds the value of:

$-197.0 - GR_x \text{ dB(W/(m}^2 \cdot \text{Hz))}$  with regard to the assignment in the Regions 1 and 3 feeder-link Plan or

$-193.9 - GR_x \text{ dB(W/(m}^2 \cdot \text{Hz))}$ , with regard to the assignment included in the feeder-link List or for which complete Appendix 4 information has been received by the Radiocommunication Bureau in accordance with the provisions of § 4.1.3,

where  $GR_x$  is the relative receive antenna gain of the space station subject to a Plan at the location of the transmitting earth station in the fixed-satellite service not for feeder links for the broadcasting-satellite service. (WRC-15)

## APPENDIX 30B (REV.WRC-19)

**Provisions and associated Plan for the fixed-satellite service  
in the frequency bands 4 500-4 800 MHz, 6 725-7 025 MHz,  
10.70-10.95 GHz, 11.20-11.45 GHz and 12.75-13.25 GHz**

## TABLE OF CONTENTS

	<i>Page</i>
Article 1	Objective of the provisions and associated Plan ..... 2
Article 2	Definitions ..... 2
Article 3	Frequency bands..... 3
Article 4	Execution of the provisions and associated Plan..... 3
Article 5	(SUP - WRC-07)
Article 6	Procedures for the conversion of an allotment into an assignment, for the introduction of an additional system or for the modification of an assignment in the List..... 4
Article 7	Procedure for the addition of a new allotment to the Plan for a new Member State of the Union..... 11
Article 8	Procedure for notification and recording in the Master Register of assignments in the planned bands for the fixed-satellite service..... 12
Article 9	General provisions..... 15
Article 10	Plan for the fixed-satellite service in the frequency bands 4 500-4 800 MHz, 6 725-7 025 MHz, 10.70-10.95 GHz, 11.20-11.45 GHz and 12.75-13.25 GHz ..... 15
Article 11	Period of validity of the provisions and associated Plan..... 27
<b>ANNEXES</b>	
Annex 1	Parameters used in characterizing the fixed-satellite service allotment Plan... 27
Annex 2	(SUP - WRC-07)
Annex 3	Limits applicable to submissions received under Article 6 or Article 7 ..... 31
Annex 4	Criteria for determining whether an allotment or an assignment is considered to be affected ..... 32
Appendix 1 to Annex 4	Method for determination of the overall single-entry and aggregate carrier-to-interference value averaged over the necessary bandwidth of the modulated carrier ..... 34
Appendix 2 to Annex 4	Method for determination of the carrier-to-noise (C/N) values ..... 36
Annex 5	(SUP - WRC-07)
Annex 6	(SUP - WRC-07)

*Note by the Secretariat:* Reference to an Article with the number in roman is referring to an Article in this Appendix.



ARTICLE 1 (REV.WRC-07)

**Objective of the provisions and associated Plan**

1.1 The objective of the procedures prescribed in this Appendix is to guarantee in practice, for all countries, equitable access to the geostationary-satellite orbit in the frequency bands of the fixed-satellite service covered by this Appendix.

1.2 The procedures prescribed in this Appendix shall in no way prevent the implementation of assignments in conformity with the national allotments of the Plan. (WRC-07)

ARTICLE 2 (REV.WRC-07)

**Definitions**

2.1 *Conference*: World Administrative Radio Conference on the Use of the Geostationary-Satellite Orbit and the Planning of Space Services Utilizing It, First Session, Geneva, 1985; Second Session, Geneva, 1988.

2.2 *Plan*: The Plan for the fixed-satellite service in the frequency bands contained in this Appendix, consisting of national allotments. (WRC-07)

2.2bis *List of assignments (hereinafter, called the "List")*: The List associated with the Plan containing assignments resulting from the successful application of the provisions of Article 6 of Appendix **30B** or the application of Resolution **148 (WRC-07)**. (WRC-07)

2.3 *Allotment*: For the purpose of this Appendix, an allotment comprises:

- a nominal orbital position;
- a bandwidth of 800 MHz (up-link and down-link) in the frequency bands listed in Article 3 of this Appendix;
- a service area for national coverage. (WRC-07)

2.4 *Existing systems*: Those satellite systems in the frequency bands covered by this Appendix which are identified in Resolution **148 (WRC-07)**. (WRC-07)

2.5 (SUP - WRC-07)

2.6 *Additional system*: For the application of the provisions of this Appendix, an additional system is a system for which the assignments submitted by an administration are not the result of conversion of an allotment into assignments. When submitting an additional system, the national allotment in the Plan of the submitting administration shall be retained. An additional system may also be submitted on behalf of a group of named administrations, with one administration designated to act as the notifying administration in respect of that additional system. (WRC-07)

2.6bis When submitting additional system(s), administrations shall fully comply with the requirements stipulated in Article 44 of the ITU Constitution. In particular, these administrations shall limit the number of orbital positions and associated spectrum so that:

- a) the orbital/spectrum natural resources are used rationally, efficiently and economically;  
*and*
- b) the use of multiple orbital locations to cover the same service area is avoided. (WRC-07)

## ARTICLE 3

### Frequency bands

3.1 The provisions of this Appendix shall apply to the fixed-satellite service in the frequency bands between:

- 4 500 and 4 800 MHz (space-to-Earth);
- 6 725 and 7 025 MHz (Earth-to-space);
- 10.70 and 10.95 GHz (space-to-Earth);
- 11.20 and 11.45 GHz (space-to-Earth);
- 12.75 and 13.25 GHz (Earth-to-space).

## ARTICLE 4

### Execution of the provisions and associated Plan

4.1 The Member States of the Union shall adopt, for their fixed-satellite service stations operating in the frequency bands referred to in this Appendix, the characteristics consistent with those specified in the Plan and its associated provisions.

4.2 The Member States of the Union shall not change the characteristics, or bring into use assignments to fixed-satellite service stations, or stations in the other services to which these frequency bands are allocated, except as provided for in the Radio Regulations and the appropriate Articles and Annexes of this Appendix.

## ARTICLE 5 (SUP - WRC-07)

## ARTICLE 6 (REV.WRC-19)

**Procedures for the conversion of an allotment into an assignment, for  
the introduction of an additional system or for the modification of  
an assignment in the List**<sup>1, 2, 2bis</sup> (WRC-19)

6.1 When an administration intends to convert an allotment into an assignment or when an administration, or one acting on behalf of a group of named administrations<sup>3</sup>, intends to introduce an additional system or modify the characteristics of assignments in the List that have been brought into use, it shall, not earlier than eight years and preferably not later than two years before the planned date of bringing the assignment into use, send to the Bureau the information specified in Appendix 4<sup>4, 5</sup>. (WRC-19)

6.1bis Administrations, in submitting an additional use under § 6.1 of Appendix 30B, may submit the information specified in Appendix 4 for both sub-bands each of 250 MHz (10.7-10.95 GHz and 11.2-11.45 GHz for downlink and 12.75-13.0 GHz and 13.0-13.25 GHz for uplink) and notify and bring into use under Article 8 only one of the two sub-bands each of 250 MHz (10.7-10.95 GHz or 11.2-11.45 GHz for downlink and 12.75-13.0 GHz or 13.0-13.25 GHz for uplink) or submit under § 6.1 either of the two sub-bands each of 250 MHz (10.7-10.95 GHz or 11.2-11.45 GHz for downlink and 12.75-13.0 GHz or 13.0-13.25 GHz for uplink) and notify and bring into use that sub-band under Article 8. The Bureau shall process that sub-band as it has been submitted under Article 6 and shall apply Article 8 for the sub-band notified and brought into use and cancel the other sub-band from its database. (WRC-19)

6.2 If the information received by the Bureau under § 6.1 is found to be incomplete, the Bureau shall immediately seek any clarification required and information not provided from the administration concerned.

---

<sup>1</sup> If the payments are not received in accordance with the provisions of Council Decision 482, as amended, on the implementation of cost recovery for satellite network filings, the Bureau shall cancel the publication specified in § 6.7 and/or 6.23 and the corresponding entries in the List under § 6.23 and/or 6.25, as appropriate, and reinstate any allotments back into the Plan after informing the administration concerned. The Bureau shall inform all administrations of such action and that the network specified in the publication in question no longer has to be taken into consideration by the Bureau and other administrations. The Bureau shall send a reminder to the notifying administration not later than two months prior to the deadline for the payment in accordance with the above-mentioned Council Decision 482, unless the payment has already been received. See also Resolution 905 (WRC-07)\*.

\* *Note by the Secretariat:* This Resolution was abrogated by WRC-12.

<sup>2</sup> Resolution 49 (Rev.WRC-15) applies. (WRC-15)

<sup>2bis</sup> Resolution 170 (WRC-19) applies. (WRC-19)

<sup>3</sup> Whenever, under § 6.1, an administration acts on behalf of a group of named administrations, all members of that group retain the right to respond in respect of their own allotments or assignments.

<sup>4</sup> Submissions may include conversion of the 6/4 GHz or the 13/10-11 GHz portion (both uplink and downlink) of an allotment into an assignment provided that the orbital location of the assignment is the same as the unconverted portion of the allotment.

<sup>5</sup> Submissions for additional systems may include use of only space-to-Earth or only Earth-to-space links.

6.3 Upon receipt of a complete notice under § 6.1, the Bureau shall examine it with respect to its conformity with:

- a) the Table of Frequency Allocations and the other provisions<sup>6</sup> of the Radio Regulations, except those provisions relating to conformity with the fixed-satellite service Plan; *and*
- b) Annex 3 to this Appendix.

6.4 When the examination with respect to § 6.3 leads to an unfavourable finding, the relevant part of the notice shall be returned to the notifying administration with an indication of the appropriate action.

6.5 When the examination of each assignment in a notice received under § 6.1 with respect to § 6.3 leads to a favourable finding, the Bureau shall use the method of Annex 4 to determine administrations whose:

- a) allotments in the Plan; *or*
- b) assignments which appear in the List; *or*
- c) assignments which the Bureau has previously examined under this paragraph after receiving complete information in accordance with § 6.1 of this Article,

are considered as being affected by any assignment in that notice.

6.6 The Bureau shall then identify those administrations whose territories have been included in the service area of the assignment under examination. The notifying administration shall seek the agreement of any administration whose territory is partially or wholly included in the intended service area of the assignment.

6.7 The Bureau shall publish, in a Special Section of its International Frequency Information Circular (BR IFIC), the complete information received under § 6.1 and examined under § 6.5, together with:

- a) the names of the administrations identified under § 6.5 and the corresponding allotments in the Plan, assignments in the List and assignments for which the Bureau has previously received complete information in accordance with § 6.1 and which it has examined under § 6.5 of this Article;
- b) the names of the administrations identified under § 6.6.

6.8 Following the examination under § 6.5 and 6.6, the Bureau shall immediately send a telegram or fax to the administration that has submitted the notice under § 6.1, drawing attention to the requirement to seek and obtain the agreement of those administrations identified in the Special Section of the BR IFIC published under § 6.7.

6.9 The Bureau shall also send a telegram or fax to each administration listed in the Special Section of the BR IFIC published under § 6.7, drawing its attention to the information it contains.

6.10 Comments from administrations identified as affected under § 6.5 in the Special Section of the BR IFIC published under § 6.7 shall be sent to the Bureau and to the administration that has submitted the notice under § 6.1, either directly or through the Bureau, within a period of four months following the date of the publication in the BR IFIC. When an administration has not replied within this four-month period, it is deemed that this administration has not agreed to the proposed assignment, unless the provisions of § 6.13 to 6.15 are applied.

---

<sup>6</sup> The “other provisions” shall be identified and included in the Rules of Procedure.

## AP30B-6

The above-mentioned four-month period shall be extended for an administration that has requested the assistance of the Bureau by up to thirty days following the date on which the Bureau communicated the result of its action.

6.11 Thirty days prior to the expiry of the same four month period, the Bureau shall dispatch a reminder telegram or fax to each administration listed in the Special Section published under § 6.7 which has not made its comments under § 6.10, bringing the matter to its attention.

6.12 An administration which considers that it should have been identified as affected in the publication referred to under § 6.7 above shall, within four months of the date of publication of the relevant BR IFIC, request the Bureau to include its name in the publication while providing the reasons therefor. The Bureau shall study this information on the basis of Annex 4 and shall inform both the affected administration and the administration that submitted the notice of its conclusions. Should the Bureau agree to the administration's request, it shall publish an addendum to the publication under § 6.7.

6.13 After the same time period as specified in § 6.10, the notifying administration may request the Bureau to assist in respect of an administration which has not replied within this time period.

6.14 The Bureau, acting on a request for assistance under § 6.13, shall send a reminder to the administration which has not replied, together with the results of its previously published compatibility analysis, containing the change in the values referred to in paragraph 2.3 of Annex 4 to Appendix **30B**, requesting a decision. (WRC-15)

6.14*bis* Fifteen days before the expiry of the 30-day period referred to in § 6.15, the Bureau shall send a reminder to the above-mentioned administration drawing its attention to the consequence of no reply.

6.15 If no decision is communicated to the Bureau within thirty days after the date of dispatch of the reminder under § 6.14, it shall be deemed that the administration which has not given a decision has agreed to the proposed assignment.

6.15*bis* The course of action described in §§ 6.13 to 6.15 do not apply to the agreement requested under § 6.6. (WRC-19)

6.15*ter* The agreement of the administrations affected may also be obtained in accordance with this Article for a specified period. When this specific period of agreement expires for an assignment in the List, the assignment in question shall be maintained in the List until the end of the period referred to in § 6.1 above. After that date this assignment in the List shall lapse unless the agreement of the administrations affected is renewed. (WRC-19)

6.16 An administration may at any time during or after the above-mentioned four-month period inform the Bureau about its objection to being included in the service area of any assignment, even if this assignment has been entered in the List. The Bureau shall then inform the administration responsible for the assignment and exclude the territory and test points<sup>6*bis*</sup> that are within the territory of the objecting administration from the service area. The Bureau shall update the reference situation without reviewing the previous examinations. (WRC-19)

---

<sup>6*bis*</sup> The administration responsible for the assignment may request to relocate the downlink test points from the excluded territory to a new location within the remaining part of its service area. (WRC-19)

6.17 If agreements have been reached with administrations published in accordance with § 6.7, the administration proposing the new or modified assignment may request the Bureau to have the assignment entered into the List, indicating the final characteristics of the assignment together with the names of the administrations with which agreement has been reached. For this purpose, it shall send to the Bureau the information specified in Appendix 4. In submitting this notice, the administration may request the Bureau to examine the notice under §§ 6.19, 6.21 and 6.22 (entry into the List) and then under Article 8 of this Appendix (notification)<sup>6ter</sup>. (WRC-19)

6.17bis An administration that has submitted the notice for an additional use under § 6.1 may request the Bureau to enter into the List only one sub-band of 250 MHz (10.7-10.95 GHz or 11.2-11.45 GHz for downlink and 12.75-13.0 GHz or 13.0-13.25 GHz for uplink). (WRC-19)

6.18 If the information received by the Bureau under § 6.17 is found to be incomplete, the Bureau shall immediately seek any clarification required and information not provided from the administration concerned.

6.19 Upon receipt of a complete notice under § 6.17, the Bureau shall examine each assignment in the notice:

- a) with respect to the requirement for the notifying administration to seek the agreement of those administrations whose territories are included in the service area; (WRC-19);
- b) with respect to its conformity with respect to the Table of Frequency Allocations and the other provisions<sup>7</sup> of the Radio Regulations, except those provisions relating to conformity with the fixed-satellite service Plan; *and*
- c) with respect to its conformity with Annex 3 to this Appendix.

6.20 When the examination with respect to § 6.19 of an assignment received under § 6.17 leads to an unfavourable finding, the notice shall be returned to the notifying administration with an indication that subsequent resubmission under § 6.17 will be considered with a new date of receipt.

6.21 When the examination with respect to § 6.19 of an assignment received under § 6.17 leads to a favourable finding, the Bureau shall use the method of Annex 4 to examine if there is any administration and the corresponding:

- a) allotment in the Plan;
- b) assignment which appears in the List at the date of receipt of the examined notice submitted under § 6.1;

---

<sup>6ter</sup> A single notice containing the information specified in Appendix 4 under Article 8 of Appendix 30B (notification) shall be submitted. When examining the notice under §§ 6.19, 6.21 and 6.22 of Article 6 of Appendix 30B, the Bureau shall use the values of the maximum power density per frequency group contained in the submitted notice as well as predefined values for the assigned frequency (10.825 GHz for 10.7-10.95 GHz, 11.325 GHz for 11.20-11.45 GHz, 12.875 GHz for 12.75-13 GHz, 13.125 GHz for 13-13.25 GHz, 4 650 MHz for 4 500-4 800 MHz and 6 875 MHz for 6 725-7 025 MHz) and the necessary bandwidth (250 MHz for 13/11 GHz or 300 MHz for 6/4 GHz). (WRC-19)

<sup>7</sup> The “other provisions” shall be identified and included in the Rules of Procedure.

- c) assignment for which the Bureau has previously received complete information in accordance with § 6.1 and has conducted the examination under § 6.5 of this Article at the date of receipt of the examined notice submitted under § 6.1<sup>7bis</sup>;

considered as being affected and whose agreement has not been provided under § 6.17. (WRC-19)

6.22 The Bureau shall determine if the final characteristics of an assignment received under § 6.17 cause more interference by checking if they decrease the uplink and/or downlink single-entry *C/I* value of an allotment in the Plan or an assignment in the List or an assignment for which the Bureau has received complete information in accordance with this Article before the date of receipt of the complete notice under § 6.17. If the final characteristics cause more interference than was produced by the characteristics previously submitted under § 6.1 to an allotment in the Plan or assignment in the List or assignment for which the Bureau has received complete information in accordance with this Article, the Bureau shall use the method of Annex 4 to determine whether that allotment or assignment is considered as being affected by the proposed assignment without the explicit agreement of the identified administrations.

6.23 In the event of a favourable finding under § 6.21 and 6.22, the Bureau shall enter the proposed assignment in the List<sup>8</sup> and publish in a Special Section of its BR IFIC the characteristics of the assignment received under § 6.17, together with the names of administrations with which the provisions of this Article have been successfully applied. The administration may then notify the assignment in accordance with Article 8 of this Appendix.

6.24 When the examination under § 6.21 or 6.22 leads to an unfavourable finding, the Bureau shall return the notice received under § 6.17 to the notifying administration together with the names of the administrations with which necessary agreements under § 6.21 or 6.22 have not been provided and with an indication that subsequent resubmission under § 6.17 will be considered with a new date of receipt.

6.25 After a notice is returned under § 6.24, should the notifying administration resubmit the notice and insist upon its reconsideration, the Bureau, on the condition of a favourable finding under § 6.21 and 6.22 with respect to allotments in the Plan, shall enter the assignment provisionally in the List, with an indication of those administrations whose assignments were the basis of the unfavourable finding. The entry in the List shall be changed from provisional to definitive only if the Bureau is informed that all required agreements have been obtained.

6.26 Notices submitted under § 6.25 shall also include a signed commitment by the notifying administration, indicating that use of an assignment recorded in the List under § 6.25 shall not cause unacceptable interference to, nor claim protection from, those assignments for which agreement still needs to be obtained.

---

<sup>7bis</sup> For any remaining affected networks whose assignments were entered in the List before the notice received under § 6.17, the Bureau shall use the method in Annex 4 to further examine if the remaining corresponding assignments in the List are still considered as being affected. The examination in respect of those remaining affected networks is conducted independently using the Appendix **30B** master database corresponding to the A6B Special Section that was published under § 6.23 or § 6.25. (WRC-19)

<sup>8</sup> In the case of a conversion of an allotment into an assignment, the part of the allotment that has been converted shall be removed from the Plan and the reference situation shall be updated.

6.27 When an assignment is entered provisionally in the List under the provisions of § 6.25, that assignment shall not be taken into account in updating the reference situation of those assignments which were the basis for the unfavourable finding. If the Bureau is informed that an agreement has been reached with respect to a given assignment, the reference situation of this assignment shall be updated.

6.28 Should the assignments that were the basis of the unfavourable finding not be brought into use within the period specified in § 6.1 or within the extension period under § 6.31*bis*, then the status of the assignment in the List shall be reviewed accordingly. (WRC-12)

6.29 Should unacceptable interference be caused by an assignment entered in the List under § 6.25 to any assignment in the List which was the basis of the disagreement, the notifying administration of the assignment entered in the List under § 6.25 shall, upon receipt of advice thereof, immediately eliminate this unacceptable interference.

6.30 When an assignment included in the List is no longer required, the notifying administration shall so inform the Bureau.

6.31 The regulatory time-limit for bringing into use an assignment to a space station of a satellite network is no more than eight years from the date of receipt by the Bureau of the complete notice under § 6.1. (WRC-15)

6.31*bis* The regulatory time-limit in § 6.31 for bringing into use of an assignment to a space station of a satellite network may be extended once by not more than three years due to launch failure in the following cases:

- the destruction of the satellite intended to bring the assignment into use;
- the destruction of the satellite launched to replace an already operating satellite which is intended to be relocated to bring another assignment into use; *or*
- the satellite is launched, but fails to reach its assigned orbital location.

For this extension to be granted, the launch failure must have occurred at least five years after the date of receipt of the complete Appendix 4 data. In no case shall the period of the extension of the regulatory time-limit exceed the difference in time between the three-year period and the period remaining from the date of the launch failure to the end of the regulatory time-limit. In order to take advantage of this extension, the administration shall have, within one month of the launch failure or one month after 17 February 2012, whichever comes later, notified the Bureau in writing of such failure, and shall also provide the following information to the Bureau before the end of the regulatory time-limit of § 6.31:

- date of launch failure;
- due diligence information as required in Resolution **49 (Rev.WRC-15)**, if this Resolution applies to the satellite network in which the space station is to operate, for the assignments with respect to the satellite that suffered the launch failure, if that information has not already been provided.

If, 11 months after the request for extension, the administration has not provided to the Bureau updated Resolution **49 (Rev.WRC-15)** information, the Bureau shall promptly send a reminder to the notifying administration. If, for a satellite network or satellite system to which Resolution **49 (Rev.WRC-15)** applies, the administration has not provided to the Bureau updated Resolution **49 (Rev.WRC-15)** information for the new satellite under procurement within one year of the request for extension, the related frequency assignments shall lapse. (WRC-15)



## AP30B-10

6.32 Thirty days prior to the date of bringing into use under § 6.31 or § 6.31*bis*, the Bureau shall dispatch a reminder telegram or fax to the notifying administration which has not brought its assignment into use, bringing the matter to its attention. (WRC-12)

6.33

When:

- i) an assignment is no longer required; *or*
- ii) an assignment recorded in the List and brought into use has been suspended for a period exceeding the suspension period resulting from the application of § 8.17 below and ending after the expiry date specified in § 6.31; *or* (WRC-15)
- iii) an assignment recorded in the List has not been brought into use within the eight-year period following the receipt by the Bureau of the relevant complete information under § 6.1 (or within the extended period in the event of an extension under § 6.31*bis*), with the exception of assignments submitted by new Member States where § 6.35 and 7.7 apply,

the Bureau shall:

- a) publish in a Special Section of its BR IFIC the cancellation of the related Special Sections and the assignments recorded in the Appendix **30B** List;
- b) if the cancelled assignment is the result of a conversion of an allotment without modification, reinstate the allotment in the Appendix **30B** Plan;
- c) if the cancelled assignment is the result of the conversion of an allotment with modifications, reinstate the allotment with the same orbital location and technical parameters of the cancelled assignment except for its service area, which shall be the national territory of the administration whose allotment is being reinstated; *and*
- d) update the reference situation for the allotments of the Plan and the assignments of the List. (WRC-15)

6.34 When a proposed new or modified frequency assignment has not fulfilled all the requirements for entering the List, in accordance with § 6.23 or 6.25, by the expiry date specified in § 6.31 or § 6.31*bis* in the event of an extension under that provision, the Bureau shall publish in a Special Section of the BR IFIC the cancellation of the related Special Sections. (WRC-12)

6.35 The procedure of this Article may be applied by the administration of a country\* which has joined the Union as an ITU Member State and does not have a national allotment in the Plan or an assignment in the List stemming from the conversion of an allotment in order to include new assignments in the List. Upon completion of the procedure, the next world radiocommunication conference may be requested to consider, among the assignments included in the List after the successful completion of this procedure, the inclusion in the Plan of a new allotment over the national territory of the new Member State.

---

\* This procedure may be applied by Palestine to obtain assignments in the Appendix **30B** Plan. Such assignments are for exclusive use by Palestine, in accordance with the Israeli-Palestinian Interim Agreement of 28 September 1995, Resolution 741 of the Council notwithstanding, and Resolution 99 (Rev. Antalya, 2006) of the Plenipotentiary Conference. This is without prejudice of future agreements between the State of Israel and Palestine.

6.36 Should the assignments mentioned in § 6.35 over the national territory of the administration not be brought into use within the eight years following the receipt by the Bureau of the relevant complete information under § 6.1 or within the extension period under § 6.31*bis*, they would be retained in the List until the end of the World Radiocommunication Conference immediately following the successful completion of the procedure referred to in § 6.35. (WRC-12)

## ARTICLE 7 (REV.WRC-15)

### **Procedure for the addition of a new allotment to the Plan for a new Member State of the Union**

7.1 The administration of a country\*\* which has joined the Union as a Member State and does not have a national allotment in the Plan or an assignment stemming from the conversion of an allotment shall obtain a national allotment by the following procedure. (WRC-15)

7.2 The administration shall submit its request for an allotment to the Bureau, with the following information:

- a) the geographical coordinates of not more than 20 test points for determining the minimal ellipse to cover its national territory;
- b) the height above sea level of each of its test points;
- c) any special requirement which is to be taken into account to the extent practicable.

7.3 Upon receipt of the complete information (mentioned in § 7.2 above), the Bureau shall expeditiously and ahead of submissions for which the examination under § 6.5 has not yet started, identify appropriate technical characteristics and associated orbital locations for a prospective national allotment. The Bureau shall send this information to the requesting administration.

7.4 Upon receipt of the Bureau's response under § 7.3, the requesting administration shall, within thirty days, indicate which of the proposed orbital locations with the associated technical parameters as identified by the Bureau it has selected. During this period, the requesting administration may at any time seek the assistance of the Bureau.

7.4*bis* If a selection for an allotment under § 7.4 has not been received by the Bureau within the specified time-limit, the Bureau will resume examination of submissions under § 6.5, or subsequent submission under Article 7, as appropriate, and inform the requesting administration that its request will be processed under § 7.5 when the Bureau is informed about the selected orbit location.

---

\*\* This procedure may be applied by Palestine to obtain an allotment in the Appendix 30B Plan. Such allotment is for exclusive use by Palestine, in accordance with the Israeli-Palestinian Interim Agreement of 28 September 1995, Resolution 741 of the Council notwithstanding, and Resolution 99 (Rev. Antalya, 2006) of the Plenipotentiary Conference. This is without prejudice of future agreements between the State of Israel and Palestine.

<sup>9</sup> (SUP - WRC-15)

7.5 Upon receipt of a request under § 7.4, the Bureau shall process the request ahead of submissions for which the examination under § 6.5 has not yet started and, using Annexes 3 and 4, examine it with respect to its conformity with:

- a) the Table of Frequency Allocations and the other provisions<sup>10</sup> of the Radio Regulations, except those provisions relating to conformity with the fixed-satellite service Plan which are the subject of the following subparagraph;
- b) allotments in the Plan;
- c) assignments which appear in the List;
- d) assignments for which the Bureau has previously received complete information and which have been examined, or are at the stage of examination under § 6.5.

7.6 When the examination under § 7.5 leads to a favorable finding, the Bureau shall enter the national allotment of the new Member State of the Union in the Plan and publish the characteristics of the allotment concerned and the result of its examination in a Special Section of the BR IFIC with the updated reference situation.

7.7 In the event that the Bureau's findings under § 7.5 are unfavourable, the proposed allotment of the Member State shall be treated as a submission under § 6.1 and shall be treated by the Bureau ahead of any other submissions received under Article 6, except for submissions which were already under examination under § 6.5 by the Bureau at the time of completion of the examination of the request of the new Member State under § 7.5.

## ARTICLE 8 (WRC-15)

### **Procedure for notification and recording in the Master Register of assignments in the planned bands for the fixed-satellite service<sup>11, 12</sup> (WRC-19)**

8.1 Any assignment for which the relevant procedure of Article 6 has been successfully applied shall be notified to the Bureau using the relevant characteristics listed in Appendix 4, not earlier than three years before the assignments are brought into use. (WRC-03)

8.2 If the first notice referred to in § 8.1 has not been received by the Bureau within the eight-year period mentioned in § 6.1 of Article 6, the assignments in the List shall no longer be taken into account by the Bureau and administrations. The Bureau shall then act as if the assignment in the List has not been brought into use in conformity with § 6.1 of Article 6. The Bureau shall inform the notifying administration, three months in advance of the end of the eight-year period, of the actions it intends to take. (WRC-07)

---

<sup>10</sup> The "other provisions" shall be identified and included in the Rules of Procedure.

<sup>11</sup> If the payments are not received in accordance with the provisions of Council Decision 482, as amended, on the implementation of cost recovery for satellite network filings, the Bureau shall cancel the publication specified in §§ 8.5 and 8.12 and the corresponding entries in the Master Register under § 8.11 or § 8.16*bis*, as appropriate, after informing the administration concerned. The Bureau shall inform all administrations of such action and that any resubmitted notice shall be considered to be a new notice. The Bureau shall send a reminder to the notifying administration not later than two months prior to the deadline for the payment in accordance with the above-mentioned Council Decision 482, unless the payment has already been received. (WRC-19)

<sup>12</sup> Resolution 49 (Rev.WRC-15) applies. (WRC-15)

8.3 Notices not containing those characteristics specified in Appendix 4 as mandatory or required shall be returned with comments to help the notifying administration to complete and resubmit them, unless the information not provided is immediately forthcoming in response to an inquiry by the Bureau. (WRC-03)

8.4 (SUP - WRC-07)

8.5 Complete notices shall be marked by the Bureau with their date of receipt and shall be examined in the date order of their receipt. Following receipt of a complete notice the Bureau shall, as soon as possible after the date of entry of the corresponding assignment into the List, or within not more than two months if the corresponding assignment has already been entered into the List, publish its contents, with any diagrams and maps and the date of receipt, in the BR IFIC, which shall constitute the acknowledgement to the notifying administration of receipt of its notice. When the Bureau is not in a position to comply with the time-limit referred to above, it shall periodically so inform the administrations, giving the reasons thereof. (WRC-19)

8.6 The Bureau shall not postpone the formulation of a finding on a complete notice unless it lacks sufficient data to reach a conclusion thereon. (WRC-03)

8.7 Each notice shall be examined: (WRC-03)

8.8 *a)* with respect to its conformity with the Table of Frequency Allocations and the other provisions<sup>13</sup> of these Regulations, except those provisions relating to conformity with the fixed-satellite service Plan which are the subject of the following subparagraph; (WRC-03)

8.9 *b)* with respect to its conformity with the fixed-satellite service Plan and the associated provisions<sup>14</sup>. (WRC-07)

8.10 When the examination with respect to § 8.8 leads to a favourable finding, the assignment shall be examined further with respect to § 8.9; otherwise the notice shall be returned with an indication of the appropriate action. (WRC-03)

8.11 When the examination with respect to § 8.9 leads to a favourable finding, the assignment shall be recorded in the Master Register. When the finding is unfavourable, the notice shall be returned to the notifying administration, with an indication of the appropriate action. (WRC-03)

8.12 In every case when a new assignment is recorded in the Master Register it shall, in accordance with the provisions of Article 8, include an indication of the finding reflecting the status of the assignment. This information shall also be published in the BR IFIC. (WRC-03)

---

<sup>13</sup> The “other provisions” shall be identified and included in the Rules of Procedure. (WRC-03)

<sup>14</sup> When an administration notifies any assignment with characteristics different from those entered in the List through successful application of Article 6 of Appendix 30B, the Bureau shall undertake calculation to determine if the proposed new characteristics increase the interference level caused to other allotments and assignments in the Plan and List. The increase of the interference due to characteristics different from those entered in the List will be checked by comparing the *C/I* ratios of these other allotments and assignments, which result from the use of the proposed new characteristics of the subject assignment on the one hand, and those obtained with the characteristics of the subject assignment in the List, on the other hand. This *C/I* calculation is performed under the same technical assumptions and conditions. (WRC-07)

8.13 A notice of a change in the characteristics of an assignment already recorded, as specified in Appendix 4, shall be examined by the Bureau under § 8.8 and § 8.9, as appropriate. Any changes to the characteristics of an assignment that has been recorded and confirmed as having been brought into use shall be brought into use within eight years from the date of the notification of the modification. Any changes to the characteristics of an assignment that has been recorded but not yet brought into use shall be brought into use within the period provided for in §§ 6.1, 6.31 or 6.31*bis* of Article 6. (WRC-19)

8.14 (SUP - WRC-07)

8.15 In applying the provisions of this Article, any resubmitted notice which is received by the Bureau more than six months after the date on which the original notice was returned by the Bureau shall be considered to be a new notice. (WRC-03)

8.16 All frequency assignments notified in advance of their being brought into use shall be entered provisionally in the Master Register. Any frequency assignment provisionally recorded under this provision shall be brought into use no later than the end of the period provided for in § 6.1 or § 6.31*bis* in the event of an extension under that provision. Unless the Bureau has been informed by the notifying administration of the bringing into use of the assignment, it shall, no later than 15 days before the end of the regulatory period established under § 6.1 or § 6.31*bis*, send a reminder requesting confirmation that the assignment has been brought into use within the regulatory period. If the Bureau does not receive that confirmation within 30 days following the period provided under § 6.1 or § 6.31*bis* in the event of an extension under that provision, it shall cancel the entry in the Master Register. In the event that an extension was requested under § 6.31*bis* but the Bureau determines that the conditions for an extension under § 6.31*bis* are not met, the Bureau shall inform the administration of its findings and cancel the entry in the Master Register. (WRC-12)

8.16*bis* In the event that the Bureau has been informed of agreement to new or modified frequency assignments in the List for a specified period of time in accordance with Article 6, the frequency assignment shall be recorded in the Master Register with a note indicating that the frequency assignment is valid only for the period specified<sup>14*bis*</sup>. The notifying administration using the frequency assignment over a specified period shall not subsequently invoke this fact to justify the continued use of the frequency beyond the period specified unless it obtains the agreement of the administration(s) concerned. (WRC-19)

8.17 Wherever the use of a recorded frequency assignment to a space station is suspended for a period exceeding six months, the notifying administration shall inform the Bureau of the date on which such use was suspended. When the recorded assignment is brought back into use, the notifying administration shall so inform the Bureau, as soon as possible. On receipt of the information sent under this provision, the Bureau shall make that information available on the ITU website as soon as possible and shall publish it in the BR IFIC. The date on which the assignment is brought back into use<sup>14*ter*</sup> shall be no later than three years from the date on which the use of the frequency assignment was suspended, provided that the notifying administration informs the Bureau of the suspension within six months from the date on which the use was suspended. If the notifying administration

---

<sup>14*bis*</sup> Unless the Bureau has been informed by the notifying administration of the renewal of the agreement, it shall, no later than six months before the end of the specified period, send a reminder to the notifying administration. (WRC-19)

<sup>14*ter*</sup> The date of bringing back into use of a frequency assignment to a space station in the geostationary-satellite orbit shall be the date of the commencement of the 90-day period defined below. A frequency assignment to a space station in the geostationary-satellite orbit shall be considered as having been brought back into use when a space station in the geostationary-satellite orbit with the capability of transmitting or receiving that frequency assignment has been deployed and maintained at the notified orbital position for a continuous period of 90 days. The notifying administration shall inform the Bureau within 30 days from the end of the 90-day period. Resolution 40 (Rev.WRC-19) shall apply. (WRC-19)

informs the Bureau of the suspension more than six months after the date on which the use of the frequency assignment was suspended, this three-year time period shall be reduced. In this case, the amount by which the three-year period shall be reduced shall be equal to the amount of time that has elapsed between the end of the six-month period and the date that the Bureau is informed of the suspension. If the notifying administration informs the Bureau of the suspension more than 21 months after the date on which the use of the frequency assignment was suspended, the frequency assignment shall be cancelled from the Master Register and the Bureau shall apply the provisions of § 6.33. (WRC-19)

8.18 No provision of this Appendix shall be considered as modifying the requirements of Article 9 relating to coordination between earth stations in the fixed-satellite service and stations of terrestrial services sharing the planned bands on an equal primary basis. (WRC-03)

8.19 Notification of assignments to a specific earth station using assignments included in the List shall be effected applying the provisions of Article 11. (WRC-03)

ARTICLE 9 (REV.WRC-07)

**General provisions**

9.1 The Plan is limited to national systems providing a domestic service. Administrations may, however, in accordance with the provisions of Article 6, convert their allotments or propose additional systems to provide national or multinational services.

9.2 (SUP - WRC-07)

ARTICLE 10 (REV.WRC-19)

**Plan for the fixed-satellite service in the frequency bands  
4 500-4 800 MHz, 6 725-7 025 MHz, 10.70-10.95 GHz,  
11.20-11.45 GHz and 12.75-13.25 GHz**

A.1 COLUMN HEADINGS OF THE PLAN

Col. 2 *Nominal orbital position*, in degrees

Col. 3 *Longitude of the boresight*, in degrees

Col. 4 *Latitude of the boresight*, in degrees

## AP30B-16

- Col. 5 *Major axis of the elliptical cross-section half-power beam, in degrees*
- Col. 6 *Minor axis of the elliptical cross-section half-power beam, in degrees*
- Col. 7 *Orientation of the ellipse determined as follows: in a plane normal to the beam axis, the direction of the major axis of the ellipse is defined by the angle measured anticlockwise from a line parallel to the equatorial plane to the major axis of the ellipse, to the nearest degree*
- Col. 8 Earth station *e.i.r.p.* density (dB(W/Hz))
- Col. 9 Satellite *e.i.r.p.* density (dB(W/Hz))
- Col. 10 *Remarks*

- 1 Assignment converted from allotment.
- 2 The Administration of Luxembourg (LUX) agreed to operate the LUX-30B-6 satellite network within the characteristics included in the Appendix **30B** List, as modified during WRC-07, and to immediately eliminate interference that could be caused by LUX-30B-6 to the national allotment of the Islamic Republic of Iran (IRN00000) (IRN).
- 3 Allotment converted into assignment with a shaped beam and then reinstated back into the Plan.
- 4-5 (SUP - WRC-07)
- 6 Allotment reinstated from assignments which were provisionally entered in the List in accordance with § 6.25. §§ 6.26 to 6.29 apply. (WRC-15)

*Note by the Secretariat (applicable when an asterisk (\*) appears in column 10):* It is to be noted that this beam is intended to be implemented as part of a multi-beam network, operating from a single orbital location. Within any multi-beam network, the beams are the responsibility of a single administration, hence interference between them has not been taken into account during the Conference. The number which appears in the alphanumeric code that follows the asterisk serves to identify the multi-beam network concerned.

## 4 500-4 800 MHz, 6 725-7 025 MHz

1	2	3	4	5	6	7	8	9	10
ABW00000	-98.20	-69.10	12.40	1.60	1.60	90.00	-9.6	-41.4	
ADL00000	113.00	140.00	-66.70	1.60	1.60	90.00	-9.6	-41.3	*/MB1
AFG00000	50.00	66.40	33.90	2.20	1.60	15.00	-9.6	-39.4	
AFS00000	71.00	27.20	-30.10	5.30	1.60	128.00	-7.8	-38.6	
AGL00000	-36.10	15.90	-12.40	2.40	1.60	78.00	-9.6	-39.1	
ALB00000	4.13	20.00	41.10	1.60	1.60	90.00	-9.6	-41.4	
ALG00000	-33.50	1.60	27.80	3.30	2.20	133.00	-8.6	-38.9	
ALS00000	-159.00	-158.60	57.50	6.30	1.60	1.00	-7.9	-38.8	*/MB2
AND00000	-41.00	1.50	42.50	1.60	1.60	90.00	-9.6	-41.4	
ARG00000	-51.00	-62.00	-33.60	4.80	2.90	93.00	-2.5	-38.1	*/MB3
ARGINSUL	-51.00	-60.00	-57.50	3.60	1.60	154.00	-9.6	-38.5	*/MB3
ARM00000	71.40	45.13	40.12	1.60	1.60	90.00	-9.6	-40.4	
ARS00000	51.90	45.70	23.10	3.70	2.60	153.00	-8.7	-39.3	
ASCSTHTC	-37.10	-11.80	-19.60	5.60	1.80	77.00	-8.0	-39.0	*/MB4
ATG00000	-77.70	-61.80	17.00	1.60	1.60	90.00	-9.6	-41.8	
AUS00001	144.10	134.30	-24.50	6.60	5.30	146.00	1.9	-38.2	*/MB6
AUS00002	144.10	163.60	-30.50	1.60	1.60	90.00	-9.6	-39.5	*/MB6
AUS00003	144.10	101.50	-11.10	1.60	1.60	90.00	-9.6	-40.5	*/MB6
AUS00004	144.10	159.00	-54.50	1.60	1.60	90.00	-9.6	-41.6	*/MB6
AUS00005	144.10	110.40	-66.30	1.60	1.60	90.00	-9.6	-41.3	*/MB6
AUT00000	-11.40	13.20	47.50	1.60	1.60	90.00	-9.6	-40.8	
AZE00000	95.90	47.20	40.34	1.60	1.60	0.00	-9.6	-42.2	
AZR00000	-10.60	-28.00	38.70	1.60	1.60	90.00	-9.6	-41.1	*/MB7
B 00001	-65.00								1
B 00002	-56.50								1
B 00003	-69.45	-50.00	-20.90	4.30	3.00	60.00	-3.4	-38.5	
BAH00000	-74.30	-75.80	24.00	1.60	1.60	133.00	-9.6	-39.4	
BDI00000	-3.50	29.90	-3.40	1.60	1.60	90.00	-9.6	-41.6	
BEL00000	54.55	5.20	50.60	1.60	1.60	90.00	-9.6	-41.2	
BEN00000	-30.60	2.30	9.30	1.60	1.60	90.00	-9.6	-39.9	
BERCAYS	-37.10	-68.60	22.50	3.70	2.30	41.00	-5.6	-38.2	*/MB4
BFA00000	10.79	-1.40	12.20	1.70	1.60	24.00	-9.6	-39.5	
BGD00000	133.00	90.20	24.00	1.60	1.60	90.00	-9.6	-40.3	
BHR00000	13.60	50.60	26.10	1.60	1.60	90.00	-9.6	-41.9	
BLR00000	64.40	27.01	53.60	1.60	1.60	0.00	-9.4	-41.3	
BLZ00000	-90.80	-88.60	17.20	1.60	1.60	90.00	-9.6	-41.6	
BOL00000	-34.80	-64.40	-17.10	2.70	1.70	129.00	-7.5	-38.6	
BOT00000	21.20	24.00	-21.80	1.60	1.60	90.00	-9.6	-40.0	
BRB00000	-29.60	-59.60	13.20	1.60	1.60	90.00	-9.6	-41.6	
BRM00000	111.50	97.00	18.90	3.20	1.60	88.00	-7.2	-38.8	
BRU00000	157.30	114.60	4.50	1.60	1.60	90.00	-9.6	-40.9	
BTN00000	59.10	90.40	27.00	1.60	1.60	90.00	-9.6	-41.5	
BUL00000	56.02								1
CAF00000	14.40	21.50	6.50	2.70	1.70	14.00	-8.4	-39.1	
CAN0CENT	-111.10	-96.10	51.40	4.30	2.00	155.00	-7.6	-38.4	
CAN0EAST	-107.30	-76.60	50.10	5.00	1.70	154.00	-7.0	-38.3	
CAN0WEST	-114.90	-120.10	57.40	3.10	1.90	173.00	-9.6	-38.7	



1	2	3	4	5	6	7	8	9	10
CBG00000	96.10	105.10	12.90	1.60	1.60	90.00	-9.6	-40.4	
CHL00000	-74.90	-82.60	-32.80	8.10	6.10	155.00	-0.7	-38.4	
CHN00001	101.40	103.70	35.00	8.10	4.30	2.00	-0.1	-38.3	
CHN00002	135.50	114.80	16.40	4.90	2.40	65.00	-3.6	-38.7	
CLM00000	-70.90	-74.00	5.70	4.00	2.30	121.00	-5.1	-38.9	
CLN00000	121.50	80.10	7.70	1.60	1.60	90.00	-9.6	-41.2	
CME00000	7.98	12.90	6.30	2.50	1.90	84.00	-8.4	-39.5	
CNR00000	-30.00	-15.90	28.50	1.60	1.60	90.00	-9.6	-41.3	*/MB8
COD00000	50.95	24.40	-4.60	3.90	3.50	92.00	-7.4	-38.5	
COG00000	-16.35	14.80	-0.60	2.00	1.60	63.00	-9.1	-38.8	
COM00000	94.50	44.10	-12.20	1.60	1.60	90.00	-9.6	-41.0	
CPV00000	-85.70	-24.10	16.00	1.60	1.60	90.00	-9.6	-41.3	
CTI00000	-15.76	-5.90	7.80	1.60	1.60	90.00	-9.6	-40.0	
CTR00000	-96.00	-85.30	8.20	1.60	1.60	90.00	-9.6	-40.2	
CUB00000	-80.60	-79.50	21.00	2.00	1.60	172.00	-9.6	-39.3	
CVA00000	59.00	12.50	41.90	1.60	1.60	90.00	-9.6	-41.3	
CYP00000	0.50	33.20	35.10	1.60	1.60	90.00	-9.6	-41.6	
CYPSBA00	57.50	32.90	34.60	1.60	1.60	90.00	-9.6	-41.7	*/MB9
CZE00000	-31.90	15.68	49.81	1.60	1.60	0.00	-9.6	-41.3	
D 00001	26.40	9.70	50.70	1.60	1.60	90.00	-9.6	-40.5	
D 00002	37.20	12.60	51.40	1.60	1.60	90.00	-9.6	-40.8	
DJI00000	-17.46	42.60	11.70	1.60	1.60	90.00	-9.6	-41.3	
DMA00000	-70.00	-61.30	15.30	1.60	1.60	90.00	-9.6	-41.8	
DNK00001	32.28	11.60	56.00	1.60	1.60	90.00	-9.6	-40.9	
DNK00002	-49.00	12.50	56.30	1.60	1.60	90.00	-9.6	-40.6	*/MB10
DNK00FAR	-49.00	-7.20	61.70	1.60	1.60	90.00	-9.6	-41.1	*/MB10
DOM00000	-85.40	-70.40	18.70	1.60	1.60	90.00	-9.6	-41.7	
E 00002	-30.00	-3.00	39.90	2.10	1.60	8.00	-9.6	-39.5	*/MB8
EGY00000	67.11	30.30	26.20	2.30	1.60	54.00	-9.6	-39.2	
EQA00000	-104.00	-83.10	-1.40	3.10	1.60	174.00	-7.8	-38.9	
ETH00000	58.30	40.60	10.30	2.80	2.80	64.00	-9.4	-39.4	
F 00000	-8.00								1
FIN00000	46.80	23.80	64.30	1.60	1.60	90.00	-9.6	-39.3	
FJI00000	148.80	178.50	-17.20	1.60	1.60	90.00	-9.6	-41.5	
FLKSTGGL	-37.10	-46.80	-59.60	3.70	1.60	170.00	-9.6	-38.8	*/MB4
G 00000	-37.10	-4.10	53.90	1.60	1.60	151.00	-9.6	-39.0	*/MB4
GAB00000	39.00	11.70	-0.70	1.60	1.60	90.00	-9.6	-39.8	
GDL00000	-8.00								1
GDL00002	-115.90	-61.80	16.40	1.60	1.60	90.00	-9.6	-40.3	*/MB13
GHA00000	15.90	-1.30	7.70	1.60	1.60	90.00	-9.6	-39.7	
GIB00000	57.50	-5.40	36.10	1.60	1.60	90.00	-9.6	-40.9	*/MB9
GMB00000	-34.00	-16.40	13.40	1.60	1.60	90.00	-9.6	-42.1	
GNB00000	40.00	-15.40	12.00	1.60	1.60	90.00	-9.6	-41.3	
GNE00000	-32.30	10.50	1.70	1.60	1.60	90.00	-9.6	-40.9	
GRC00000	22.05	24.70	38.30	1.70	1.60	160.00	-9.6	-39.3	
GRD00000	-32.80	-61.60	12.00	1.60	1.60	90.00	-9.6	-41.6	
GRL00000	-49.00	-42.90	68.60	2.30	1.60	174.00	-9.6	-38.6	*/MB10

## 4 500-4 800 MHz, 6 725-7 025 MHz

1	2	3	4	5	6	7	8	9	10
GTM00000	-135.70	-90.50	15.50	1.60	1.60	90.00	-9.6	-40.5	
GUF00000	-8.00								1
GUF00002	-115.90	-53.30	4.30	1.60	1.60	90.00	-8.6	-39.4	*/MB13
GUI00000	27.50	-10.90	10.20	1.60	1.60	90.00	-9.6	-39.2	
GUMMRA0	-159.00	145.40	16.70	1.70	1.60	79.00	-9.4	-38.3	*/MB2
GUY00000	-23.80	-59.20	4.70	1.60	1.60	90.00	-9.6	-39.4	
HKG00000	57.50	114.50	22.40	1.60	1.60	90.00	-9.6	-40.6	
HND00000	-76.20	-86.10	15.40	1.60	1.60	90.00	-9.6	-40.0	
HNG00000	-7.50	19.40	47.40	1.60	1.60	90.00	-9.6	-41.0	
HOL00000	-5.00	5.40	52.40	1.60	1.60	90.00	-9.6	-41.4	*/MB5
HTI00000	-92.00	-73.00	18.80	1.60	1.60	90.00	-9.6	-41.7	
HWA00000	-159.00	-157.60	20.70	1.60	1.60	90.00	-9.6	-40.2	*/MB2
HWL00000	-159.00	-176.60	0.10	1.60	1.60	90.00	-9.6	-41.8	*/MB2
I 00000	-23.40	11.30	40.90	2.10	1.60	141.00	-9.6	-38.9	
IND00000	74.00	82.70	18.90	6.20	4.90	120.00	0.3	-38.5	
INS00000	115.40	117.60	-1.80	9.40	4.30	170.00	1.8	-38.6	
IRL00000	-21.80	-8.20	53.20	1.60	1.60	90.00	-9.6	-41.1	
IRN00000	24.19	54.30	33.00	3.70	1.60	143.00	-9.6	-39.0	
IRQ00000	65.45	44.30	33.10	1.60	1.60	90.00	-9.6	-39.4	
ISL00000	-35.20	-18.20	64.90	1.60	1.60	90.00	-9.6	-40.5	
ISR00000	-4.00								1
J 00000	152.50	140.40	30.40	5.70	3.70	15.00	-2.3	-38.5	
JAR00000	-159.00	-160.00	-0.40	1.60	1.60	90.00	-9.6	-41.9	*/MB2
JMC00000	-108.60	-77.60	18.20	1.60	1.60	90.00	-9.6	-41.5	
JON00000	-159.00	-168.50	17.00	1.60	1.60	90.00	-9.6	-42.2	*/MB2
JOR00000	81.76	36.70	31.30	1.60	1.60	90.00	-9.6	-40.9	
KAZ00000	58.50	66.36	46.72	4.60	1.69	176.88	-9.6	-41.0	
KEN00000	78.20	38.40	0.80	2.10	1.60	95.00	-9.6	-39.3	
KER00000	113.00	69.30	-43.90	1.90	1.60	169.00	-9.6	-38.7	*/MB1
KGZ00000	64.60	74.54	41.15	1.60	1.60	90.00	-9.6	-38.8	
KIR00000	150.00	173.00	1.00	1.60	1.60	90.00	-9.6	-41.8	
KNA00000	-88.80	-62.90	17.30	1.60	1.60	90.00	-9.6	-41.6	
KOR00000	116.20	127.70	36.20	1.60	1.60	90.00	-9.6	-40.5	
KRE00000	145.00	127.80	39.80	1.60	1.60	90.00	-9.6	-39.6	
KWT00000	30.90	47.70	29.10	1.60	1.60	90.00	-9.6	-41.9	
LAO00000	142.00	104.10	18.10	1.60	1.60	90.00	-9.6	-39.1	
LBN00000	97.50	35.80	33.80	1.60	1.60	90.00	-9.6	-41.3	
LBR00000	-41.80	-8.90	6.50	1.60	1.60	90.00	-9.6	-40.4	
LBY00000	28.90	19.00	25.90	3.00	2.70	165.00	-6.8	-39.2	
LIE00000	-17.10	9.50	47.20	1.60	1.60	90.00	-9.6	-41.7	
LSO00000	-19.30	28.40	-29.50	1.60	1.60	90.00	-9.6	-41.5	
LTU00000	-9.30	23.67	55.23	1.60	1.60	0.00	-9.6	-42.8	
LUX00000	19.20	6.20	49.70	1.60	1.60	90.00	-9.6	-41.6	
MAC00000	117.00	113.60	22.20	1.60	1.60	90.00	-9.6	-41.8	
MAU00000	92.20	57.50	-20.20	1.60	1.60	90.00	-9.6	-41.4	
MCO00000	52.00						-15.6	-28.7	3, 6
MDG00000	16.90	46.60	-18.70	2.60	1.60	66.00	-7.5	-38.6	

1	2	3	4	5	6	7	8	9	10
MDR00000	-10.60	-16.20	31.60	1.60	1.60	90.00	-9.6	-41.7	*/MB7
MDW00000	-159.00	-177.40	28.20	1.60	1.60	90.00	-9.6	-42.0	*/MB2
MEX00000	-113.00	-103.60	23.30	5.80	2.40	161.00	-4.7	-38.8	
MHL00000	-159.00	175.30	8.70	2.30	1.60	94.00	-8.6	-38.8	*/MB2
MLA00000	78.50	108.20	4.70	3.20	1.60	0.00	-6.3	-38.5	
MLD00000	117.60	73.40	2.50	2.20	1.60	88.00	-9.6	-38.7	
MLI00000	-6.00	-3.90	17.60	3.30	2.50	21.00	-7.6	-39.2	
MLT00000	-3.00	14.40	35.90	1.60	1.60	90.00	-9.6	-41.8	
MNG00000	113.60	103.80	46.80	3.60	1.60	3.00	-9.6	-38.9	
MOZ00000	90.60	35.60	-17.20	3.10	1.60	98.00	-7.7	-38.3	
MRC00000	32.86	-8.90	27.90	3.40	1.60	45.00	-9.6	-38.8	
MTN00000	-21.10	-10.30	19.80	2.50	2.40	76.00	-9.6	-39.4	
MWI00000	28.00	34.10	-13.30	1.60	1.60	90.00	-9.6	-40.0	
MYT00000	-8.00								1
NCG00000	-84.40	-84.90	12.90	1.60	1.60	90.00	-9.6	-40.6	
NCL00000	113.00	165.80	-21.40	1.60	1.60	90.00	-9.6	-40.6	*/MB1
NGR00000	-38.50	7.50	17.20	2.10	1.70	100.00	-9.6	-38.9	
NIG00000	41.82	8.00	9.90	2.50	1.60	47.00	-7.7	-38.5	
NMB00000	12.20	18.50	-21.00	2.70	2.60	155.00	-9.6	-39.5	
NOR00000	-0.80	11.70	64.60	2.00	1.60	17.00	-9.6	-38.7	
NPL00000	123.30	84.40	28.00	1.60	1.60	90.00	-9.6	-40.8	
NRU00000	146.00	166.90	-0.50	1.60	1.60	90.00	-9.6	-41.8	
NZL00001	152.00	170.90	-44.80	5.40	1.60	49.00	-7.4	-38.1	*/MB14
NZL00002	152.00	-165.40	-13.20	2.70	2.00	82.00	-7.3	-38.3	*/MB14
OCE00000	-115.90	-141.90	-16.10	3.50	2.40	139.00	-7.1	-38.9	*/MB13
OMA00000	104.00	55.10	21.60	1.90	1.60	61.00	-9.6	-39.2	
PAK00000	56.50	69.90	29.80	3.00	2.00	22.00	-9.3	-39.0	
PHL00000	161.00	122.23	11.37	3.33	1.60	79.65	-6.3	-38.4	
PLM00000	-159.00	-161.40	7.00	1.60	1.60	90.00	-9.6	-41.9	*/MB2
PNG00000	154.10	148.40	-6.60	3.30	2.30	167.00	-6.2	-39.0	
PNR00000	-79.20	-80.20	8.50	1.60	1.60	90.00	-9.6	-40.4	
POL00000	15.20	19.30	52.00	1.60	1.60	90.00	-9.6	-40.0	
POR00000	-10.60	-8.00	39.70	1.60	1.60	90.00	-9.6	-41.2	*/MB7
PRG00000	-81.50	-58.70	-23.10	1.60	1.60	90.00	-9.6	-39.1	
PRU00000	-89.90	-74.20	-8.40	3.60	2.40	111.00	-5.4	-38.7	
PTC00000	-62.30	-130.10	-25.10	1.60	1.60	90.00	-9.6	-41.2	
QAT00000	0.90	51.60	25.40	1.60	1.60	90.00	-9.6	-41.6	
REU00000	-8.00								1
REU00002	113.00	55.60	-21.10	1.60	1.60	90.00	-9.6	-40.6	*/MB1
ROU00000	30.45	25.00	46.30	1.60	1.60	90.00	-9.6	-39.6	
RRW00000	17.60	29.70	-1.90	1.60	1.60	90.00	-9.6	-41.9	
RUS00001	61.00	51.50	52.99	5.56	2.01	10.74	-7.2	-38.3	
RUS00002	88.10	94.80	48.60	7.50	3.50	175.00	-1.4	-38.3	
RUS00003	138.50	138.14	53.83	5.86	2.09	8.41	-6.7	-38.2	
S 00000	5.00	16.70	60.90	1.60	1.60	90.00	-9.6	-40.2	
SDN00001	23.55	29.30	10.30	3.00	1.90	131.00	-9.3	-39.0	*/MB15
SDN00002	23.55	29.40	16.70	2.60	2.40	171.00	-9.6	-39.3	*/MB15

## 4 500-4 800 MHz, 6 725-7 025 MHz

1	2	3	4	5	6	7	8	9	10
SEN00000	-48.40	-14.00	14.10	1.60	1.60	90.00	-9.6	-40.3	
SEY00000	42.25	51.50	-3.20	13.80	3.80	48.50	-3.0	-43.8	
SLM00000	147.50	159.00	-9.10	1.60	1.60	90.00	-9.6	-39.5	
SLV00000	-130.50	-89.00	13.70	1.60	1.60	90.00	-9.6	-40.9	
SMA00000	-159.00	-170.70	-14.20	1.60	1.60	90.00	-9.6	-42.2	*/MB2
SMO00000	-125.50	-172.10	-13.70	1.60	1.60	90.00	-9.6	-41.1	
SMR00000	16.50	12.50	43.90	1.60	1.60	90.00	-9.6	-42.0	
SNG00000	98.10	103.90	1.30	1.60	1.60	90.00	-9.6	-41.6	
SOM00000	98.40	46.00	6.30	3.10	1.60	72.00	-9.6	-38.8	
SPM00000	-8.00								1
SRL00000	-51.80	-11.90	8.50	1.60	1.60	90.00	-9.6	-41.4	
STP00000	30.25	7.00	1.00	1.60	1.60	90.00	-9.6	-41.7	
SUI00000	9.45	8.20	46.50	1.60	1.60	90.00	-9.6	-41.3	
SUR00000	-77.00	-55.60	3.90	1.60	1.60	90.00	-9.6	-40.7	
SVK00000	-19.82	17.30	49.60	1.60	1.60	90.00	-9.6	-40.0	
SWZ00000	30.10	31.30	-26.40	1.60	1.60	90.00	-9.6	-42.0	
SYR00000	18.00	38.60	35.30	1.60	1.60	90.00	-9.6	-40.8	
TCDO00000	-9.90	18.40	15.60	3.50	1.60	97.00	-8.9	-39.0	
TGO00000	-23.15	0.80	8.60	1.60	1.60	90.00	-9.6	-40.4	
THA00000	120.60	100.90	12.80	2.80	1.60	83.00	-7.7	-38.8	
TON00000	-128.00	-175.20	-21.20	1.60	1.60	90.00	-9.6	-41.0	
TRD00000	-73.40	-61.10	10.80	1.60	1.60	90.00	-9.6	-41.8	
TUN00000	5.74	9.40	33.50	1.60	1.60	90.00	-9.6	-40.3	
TUR00000	8.50	34.10	38.90	2.80	1.60	171.00	-6.4	-38.6	
TUV00000	158.00	179.20	-8.50	1.60	1.60	90.00	-9.6	-41.8	
TZA00000	67.50	35.40	-5.90	2.40	1.60	117.00	-9.6	-39.3	
UAE00000	63.50	53.80	24.90	1.60	1.60	90.00	-9.6	-41.1	
UGA00000	31.50	32.20	0.90	1.60	1.60	90.00	-9.6	-40.3	
UKR00001	38.20	31.73	48.22	1.98	1.60	178.15	-15.1	-40.7	
URG00000	-86.10	-56.30	-33.70	1.60	1.60	90.00	-9.6	-40.7	
USA00000	-101.30	-93.90	36.80	8.20	3.60	172.00	-0.9	-38.3	*/MB16
USAVIPRT	-101.30	-64.50	17.80	1.60	1.60	90.00	-9.6	-41.4	*/MB16
UZB00000	110.50	65.45	41.09	1.60	1.60	0.00	-9.6	-40.3	
VCT00000	-93.10	-61.10	13.20	1.60	1.60	90.00	-9.6	-41.5	
VEN00001	-82.70	-66.40	6.80	2.80	2.10	142.00	-7.0	-38.9	*/MB17
VEN00002	-82.70	-63.60	15.70	1.60	1.60	90.00	-9.6	-41.7	*/MB17
VTN00000	107.00	16.00					-7.1	-35.8	3
VUT00000	150.70	168.40	-17.20	1.60	1.60	90.00	-9.6	-40.3	
WAK00000	-159.00	166.50	19.20	1.60	1.60	90.00	-9.6	-41.9	*/MB2
WAL00000	113.00	-177.10	-13.80	1.60	1.60	90.00	-9.0	-39.8	*/MB1
XAN00000	-5.00	-65.60	15.10	1.60	1.60	90.00	-9.6	-38.9	*/MB5
XCQ00000	-159.00	173.40	4.60	10.20	2.40	175.00	4.5	-35.6	*/MB2
XYU00000	43.04	18.70	44.40	1.60	1.60	90.00	-9.6	-40.5	
YEM00001	27.00	44.20	15.10	1.60	1.60	90.00	-9.6	-41.4	
YEM00002	108.00	49.90	14.80	1.60	1.60	90.00	-9.6	-39.7	
ZMB00000	39.55	27.90	-12.80	2.40	1.60	26.00	-9.6	-39.6	
ZWE00000	65.60	30.00	-18.90	1.60	1.60	90.00	-9.6	-39.9	

10.70-10.95 GHz, 11.20-11.45 GHz, 12.75-13.25 GHz

1	2	3	4	5	6	7	8	9	10
ABW00000	-98.20	-69.10	12.40	0.80	0.80	90.00	-6.4	-25.8	
ADL00000	113.00	140.00	-66.70	0.80	0.80	90.00	-10.2	-31.9	*/MB1
AFG00000	50.00	66.40	33.90	2.20	1.30	15.00	-4.1	-29.2	
AFS00000	71.00	27.20	-30.10	5.30	1.40	128.00	3.3	-26.7	
AGL00000	-36.10	15.90	-12.40	2.40	1.40	78.00	1.1	-25.8	
ALB00000	4.13	20.00	41.10	0.80	0.80	90.00	-8.6	-28.2	
ALG00000	-33.50	1.60	27.80	3.30	2.20	133.00	3.4	-26.6	
ALS00000	-159.00	-158.60	57.50	6.30	1.50	1.00	1.6	-28.7	*/MB2
AND00000	-41.00	1.50	42.50	0.80	0.80	90.00	-10.2	-30.0	
ARG00000	-51.00	-62.00	-33.60	4.80	2.90	93.00	9.4	-21.9	*/MB3
ARGINSUL	-51.00	-60.00	-57.50	3.60	1.30	154.00	-1.4	-28.6	*/MB3
ARM00000	71.40	45.13	40.12	0.80	0.80	90.00	-10.2	-30.1	
ARS00000	51.90	45.70	23.10	3.70	2.60	153.00	0.8	-29.4	
ASCSTHTC	-37.10	-11.80	-19.60	5.60	1.80	77.00	2.1	-28.6	*/MB4
ATG00000	-77.70	-61.80	17.00	0.80	0.80	90.00	-7.2	-27.1	
AUS00001	144.10	134.30	-24.50	6.60	5.30	146.00	13.4	-22.1	*/MB6
AUS00002	144.10	163.60	-30.50	1.60	1.00	15.00	-2.9	-26.5	*/MB6
AUS00003	144.10	101.50	-11.10	1.10	1.00	15.00	-6.9	-28.5	*/MB6
AUS00004	144.10	159.00	-54.50	0.80	0.80	90.00	-10.2	-32.3	*/MB6
AUS00005	144.10	110.40	-66.30	0.80	0.80	90.00	-10.2	-31.8	*/MB6
AUT00000	-11.40	13.20	47.50	0.80	0.80	90.00	-8.1	-27.2	
AZE00000	95.90	47.20	40.34	0.80	0.80	0.00	-10.2	-31.0	
AZR00000	-10.60	-28.00	38.70	0.80	0.80	90.00	-8.7	-27.9	*/MB7
B 00001	-65.00								1
B 00002	-56.50								1
B 00003	-69.45	-50.00	-20.90	4.30	3.00	60.00	8.9	-22.2	
BAH00000	-74.30	-75.80	24.00	1.60	1.00	133.00	-0.8	-24.5	
BDI00000	-3.50	29.90	-3.40	0.80	0.80	90.00	-10.2	-29.9	
BEL00000	54.55	5.20	50.60	0.80	0.80	90.00	-10.2	-30.2	
BEN00000	-30.60	2.30	9.30	1.20	1.00	89.00	-2.1	-23.0	
BERCAYS	-37.10	-68.60	22.50	3.70	2.30	41.00	7.4	-21.8	*/MB4
BFA00000	10.79	-1.40	12.20	1.70	1.00	24.00	-0.6	-25.0	
BGD00000	133.00	90.20	24.00	0.80	0.80	90.00	-3.9	-21.9	
BHR00000	13.60	50.60	26.10	0.80	0.80	90.00	-10.2	-32.2	
BLR00000	64.40	27.01	53.60	1.14	0.80	25.74	-3.0	-30.0	
BLZ00000	-90.80	-88.60	17.20	0.80	0.80	90.00	-6.5	-26.6	
BOL00000	-34.80	-64.40	-17.10	2.70	1.70	129.00	4.3	-22.5	
BOT00000	21.20	24.00	-21.80	1.50	1.50	94.00	-6.0	-30.0	
BRB00000	-29.60	-59.60	13.20	0.80	0.80	90.00	-7.0	-26.4	
BRM00000	111.50	97.00	18.90	3.20	1.60	88.00	4.6	-22.6	
BRU00000	157.30	114.60	4.50	0.80	0.80	90.00	-6.9	-24.9	
BTN00000	59.10	90.40	27.00	0.80	0.80	90.00	-10.2	-29.3	
BUL00000	56.02								1
CAF00000	14.40	21.50	6.50	2.70	1.70	14.00	3.8	-22.8	
CANOCENT	-111.10	-96.10	51.40	4.30	2.00	155.00	3.9	-26.7	
CANOEAST	-107.30	-76.60	50.10	5.00	1.70	154.00	6.2	-25.0	
CANOWEST	-114.90	-120.10	57.40	3.10	1.90	173.00	-0.6	-28.7	

## 10.70-10.95 GHz, 11.20-11.45 GHz, 12.75-13.25 GHz

1	2	3	4	5	6	7	8	9	10
CBG00000	96.10	105.10	12.90	1.20	1.00	35.00	-2.5	-23.2	
CHL00000	-74.90	-82.60	-32.80	8.10	6.10	155.00	9.0	-28.4	
CHN00001	101.40	103.70	35.00	8.10	4.30	2.00	13.6	-23.2	
CHN00002	135.50	114.80	16.40	4.90	2.40	65.00	8.2	-22.5	
CLM00000	-70.90	-74.00	5.70	4.00	2.30	121.00	7.1	-22.6	
CLN00000	121.50	80.10	7.70	0.80	0.80	90.00	-6.5	-24.8	
CME00000	7.98	12.90	6.30	2.50	1.90	84.00	3.9	-22.7	
CNR00000	-30.00								1
COD00000	50.95	24.40	-4.60	3.90	3.50	92.00	6.5	-24.4	
COG00000	-16.35	14.80	-0.60	2.00	1.10	63.00	0.7	-22.7	
COM00000	94.50	44.10	-12.20	0.80	0.80	90.00	-6.7	-24.7	
CPV00000	-85.70	-24.10	16.00	0.80	0.80	90.00	-10.2	-30.4	
CTI00000	-15.76	-5.90	7.80	1.40	1.20	66.00	-0.9	-23.1	
CTR00000	-96.00	-85.30	8.20	1.30	1.00	64.00	-2.1	-23.2	
CUB00000	-80.60	-79.50	21.00	2.00	1.00	172.00	0.1	-24.6	
CVA00000	59.00	12.50	41.90	0.80	0.80	90.00	-9.3	-28.8	
CYP00000	0.50	33.20	35.10	0.80	0.80	90.00	-10.2	-29.8	
CYPSBA00	57.50	32.90	34.60	0.80	0.80	90.00	-10.2	-30.2	*/MB9
CZE00000	-31.90	15.68	49.81	0.80	0.80	0.00	-8.4	-30.5	
D 00001	26.40	9.70	50.70	1.10	1.00	41.00	-7.7	-28.7	
D 00002	37.20	12.60	51.40	0.80	0.80	90.00	-9.3	-28.2	
DJI00000	-17.46	42.60	11.70	0.80	0.80	90.00	-10.2	-30.1	
DMA00000	-70.00	-61.30	15.30	0.80	0.80	90.00	-7.3	-27.3	
DNK00001	32.28	11.60	56.00	0.80	0.80	90.00	-10.2	-29.0	
DNK00002	-49.00	12.50	56.30	0.80	0.80	90.00	-8.2	-27.7	*/MB10
DNK00FAR	-49.00	-7.20	61.70	0.80	0.80	90.00	-10.2	-29.5	*/MB10
DOM00000	-85.40	-70.40	18.70	0.80	0.80	90.00	-7.2	-27.1	
E 00002	-30.00								1
EGY00000	67.11	30.30	26.20	2.30	1.50	54.00	-2.7	-28.8	
EQA00000	-104.00	-83.10	-1.40	3.10	1.40	174.00	3.8	-22.7	
ETH00000	58.30	40.60	10.30	2.80	2.80	64.00	1.1	-28.6	
F 00000	-8.00								1
FIN00000	46.80	23.80	64.30	1.50	1.00	23.00	-6.2	-28.6	
FJI00000	148.80	178.50	-17.20	0.80	0.80	90.00	-7.0	-26.2	
FLKSTGGL	-37.10	-46.80	-59.60	3.70	1.40	170.00	-0.9	-28.7	*/MB4
G 00000	-37.10	-4.10	53.90	1.60	1.00	151.00	-4.7	-27.8	*/MB4
GAB00000	39.00	11.70	-0.70	1.40	1.10	79.00	-1.5	-23.0	
GDL00000	-8.00								1
GDL00002	-115.90	-61.80	16.40	0.80	0.80	90.00	-4.6	-22.7	*/MB13
GHA00000	15.90	-1.30	7.70	1.50	1.10	90.00	-1.0	-23.0	
GIB00000	57.50	-5.40	36.10	0.80	0.80	90.00	-6.8	-27.0	*/MB9
GMB00000	-34.00	-16.40	13.40	0.80	0.80	90.00	-10.2	-31.0	
GNB00000	40.00	-15.40	12.00	0.80	0.80	90.00	-9.2	-28.8	
GNE00000	-32.30	10.50	1.70	0.80	0.80	90.00	-6.8	-24.9	
GRC00000	22.05	24.70	38.30	1.70	1.00	160.00	-2.7	-26.6	
GRD00000	-32.80	-61.60	12.00	0.80	0.80	90.00	-7.1	-26.5	
GRL00000	-49.00	-42.90	68.60	2.30	1.00	174.00	-3.3	-27.8	*/MB10

## 10.70-10.95 GHz, 11.20-11.45 GHz, 12.75-13.25 GHz

1	2	3	4	5	6	7	8	9	10
GTM00000	-135.70	-90.50	15.50	0.80	0.80	90.00	-4.2	-22.2	
GUF00000	-8.00								1
GUF00002	-115.90	-53.30	4.30	0.80	0.80	90.00	-5.3	-23.4	*/MB13
GUI00000	27.50	-10.90	10.20	1.30	1.10	104.00	-1.5	-22.9	
GUMMRA0	-159.00	145.40	16.70	1.70	1.00	79.00	0.0	-22.2	*/MB2
GUY00000	-23.80	-59.20	4.70	1.40	1.00	94.00	-1.4	-22.8	
HKG00000	57.50	114.50	22.40	0.80	0.80	90.00	-6.5	-24.5	
HND00000	-76.20	-86.10	15.40	1.40	1.00	26.00	-1.8	-23.1	
HNG00000	-7.50	19.40	47.40	0.80	0.80	90.00	-8.8	-28.1	
HOL00000	-5.00	5.40	52.40	0.80	0.80	90.00	-10.2	-30.8	*/MB5
HTI00000	-92.00	-73.00	18.80	0.80	0.80	90.00	-7.1	-26.9	
HWA00000	-159.00	-157.60	20.70	1.20	1.00	157.00	-2.2	-23.1	*/MB2
HWL00000	-159.00	-176.60	0.10	0.80	0.80	90.00	-7.3	-27.4	*/MB2
I 00000	-23.40	11.30	40.90	2.10	1.00	141.00	-1.6	-26.4	
IND00000	74.00	82.70	18.90	6.20	4.90	120.00	12.6	-22.2	
INS00000	115.40	117.60	-1.80	9.40	4.30	170.00	13.7	-22.4	
IRL00000	-21.80	-8.20	53.20	0.80	0.80	90.00	-10.2	-29.3	
IRN00000	24.19	54.30	33.00	3.70	1.50	143.00	1.1	-27.5	2
IRQ00000	65.45	44.30	33.10	1.60	1.30	178.00	-4.0	-28.0	
ISL00000	-35.20	-18.20	64.90	0.80	0.80	90.00	-8.5	-27.4	
ISR00000	-4.00								1
J 00000	152.50	140.40	30.40	5.70	3.70	15.00	11.1	-22.8	
JAR00000	-159.00	-160.00	-0.40	0.80	0.80	90.00	-7.5	-27.5	*/MB2
JMC00000	-108.60	-77.60	18.20	0.80	0.80	90.00	-6.9	-25.9	
JON00000	-159.00	-168.50	17.00	0.80	0.80	90.00	-10.2	-32.5	*/MB2
JOR00000	81.76	36.70	31.30	0.80	0.80	90.00	-9.7	-28.5	
KAZ00000	58.50	66.36	46.72	4.60	1.69	176.88	-0.6	-28.0	
KEN00000	78.20	38.40	0.80	2.10	1.30	95.00	-2.1	-27.6	
KER00000	113.00	69.30	-43.90	1.90	1.60	169.00	-2.2	-27.8	*/MB1
KGZ00000	64.60	74.54	41.15	1.56	0.80	10.12	-8.3	-29.7	
KIR00000	150.00	173.00	1.00	0.80	0.80	90.00	-7.2	-27.1	
KNA00000	-88.80	-62.90	17.30	0.80	0.80	90.00	-7.1	-26.5	
KOR00000	116.20	127.70	36.20	1.30	1.00	4.00	-4.3	-26.7	
KRE00000	145.00	127.80	39.80	1.40	1.00	14.00	-1.2	-23.3	
KWT00000	30.90	47.70	29.10	0.80	0.80	90.00	-10.2	-31.6	
LAO00000	142.00	104.10	18.10	1.50	1.00	101.00	-0.7	-22.6	
LBN00000	97.50	35.80	33.80	0.80	0.80	90.00	-10.2	-30.5	
LBR00000	-41.80	-8.90	6.50	0.80	0.80	90.00	-4.0	-22.1	
LBY00000	28.90	19.00	25.90	3.00	2.70	165.00	3.1	-27.8	
LIE00000	-17.10	9.50	47.20	0.80	0.80	90.00	-10.2	-31.2	
LSO00000	-19.30	28.40	-29.50	0.80	0.80	90.00	-10.2	-31.1	
LTU00000	-9.30	23.67	55.23	0.80	0.80	0.00	-10.2	-32.5	
LUX00000	19.20	6.20	49.70	0.80	0.80	90.00	-10.2	-31.6	
MAC00000	117.00	113.60	22.20	0.80	0.80	90.00	-7.2	-27.1	
MAU00000	92.20	57.50	-20.20	0.80	0.80	90.00	-6.9	-25.6	
MCO00000	52.00								1
MDG00000	16.90	46.60	-18.70	2.60	1.00	66.00	1.6	-22.5	

## 10.70-10.95 GHz, 11.20-11.45 GHz, 12.75-13.25 GHz

1	2	3	4	5	6	7	8	9	10
MDR00000	-10.60	-16.20	31.60	0.80	0.80	90.00	-10.2	-30.5	*/MB7
MDW00000	-159.00	-177.40	28.20	0.80	0.80	90.00	-10.2	-32.2	*/MB2
MEX00000	-113.00								1
MHL00000	-159.00	175.30	8.70	2.30	1.40	94.00	2.7	-22.6	*/MB2
MLA00000	78.50	108.20	4.70	3.20	1.40	0.00	4.1	-22.3	
MLD00000	117.60	73.40	2.50	2.20	0.80	88.00	0.1	-22.4	
MLI00000	-6.00	-3.90	17.60	3.30	2.50	21.00	6.3	-24.8	
MLT00000	-3.00	14.40	35.90	0.80	0.80	90.00	-10.2	-30.4	
MNG00000	113.60	103.80	46.80	3.60	1.10	3.00	-0.3	-27.6	
MOZ00000	90.60	35.60	-17.20	3.10	1.10	98.00	3.2	-22.0	
MRC00000	32.86	-8.90	27.90	3.40	1.00	45.00	-0.5	-27.0	
MTN00000	-21.10	-10.30	19.80	2.50	2.40	76.00	0.1	-28.4	
MWI00000	28.00	34.10	-13.30	1.60	1.00	101.00	-6.7	-29.3	
MYT00000	-8.00								1
NCG00000	-84.40	-84.90	12.90	1.10	1.00	16.00	-2.8	-23.1	
NCL00000	113.00	165.80	-21.40	0.80	0.80	90.00	-5.9	-23.9	*/MB1
NGR00000	-38.50	7.50	17.20	2.10	1.70	100.00	-0.6	-27.3	
NIG00000	41.82	8.00	9.90	2.50	1.60	47.00	3.4	-22.4	
NMB00000	12.20	18.50	-21.00	2.70	2.60	155.00	-0.7	-29.6	
NOR00000	-0.80								1
NPL00000	123.30	84.40	28.00	0.80	0.80	90.00	-7.2	-26.6	
NRU00000	146.00	166.90	-0.50	0.80	0.80	90.00	-7.2	-27.2	
NZL00001	152.00	170.90	-44.80	5.40	1.00	49.00	2.0	-26.5	*/MB14
NZL00002	152.00	-165.40	-13.20	2.70	2.00	82.00	5.4	-22.0	*/MB14
OCE00000	-115.90	-141.90	-16.10	3.50	2.40	139.00	6.8	-24.2	*/MB13
OMA00000	104.00	55.10	21.60	1.90	1.00	61.00	-6.0	-29.3	
PAK00000	56.50	69.90	29.80	3.00	2.00	22.00	3.7	-25.7	
PHL00000	161.00	122.23	11.37	3.33	1.41	79.65	4.8	-22.3	
PLM00000	-159.00	-161.40	7.00	0.80	0.80	90.00	-7.6	-27.6	*/MB2
PNG00000	154.10	148.40	-6.60	3.30	2.30	167.00	6.0	-22.7	
PNR00000	-79.20	-80.20	8.50	1.20	1.00	177.00	-2.4	-23.2	
POL00000	15.20	19.30	52.00	1.30	1.00	166.00	-7.0	-28.7	
POR00000	-10.60	-8.00	39.70	0.80	0.80	90.00	-9.0	-28.1	*/MB7
PRG00000	-81.50	-58.70	-23.10	1.50	1.30	116.00	0.1	-22.8	
PRU00000	-89.90	-74.20	-8.40	3.60	2.40	111.00	6.9	-22.5	
PTC00000	-62.30	-130.10	-25.10	0.80	0.80	90.00	-10.2	-27.3	
QAT00000	0.90	51.60	25.40	0.80	0.80	90.00	-10.2	-31.5	
REU00000	-8.00								1
REU00002	113.00	55.60	-21.10	0.80	0.80	90.00	-6.4	-24.5	*/MB1
ROU00000	30.45	25.00	46.30	1.50	1.00	178.00	-5.2	-28.0	
RRW00000	17.60	29.70	-1.90	0.80	0.80	90.00	-10.2	-30.8	
RUS00001	61.00	51.50	52.99	5.56	2.01	10.74	3.1	-28.2	
RUS00002	88.10						5.4	-26.32	3
RUS00003	138.50	138.14	53.83	5.86	2.09	8.41	3.3	-28.4	
S 00000	5.00								1
SDN00001	23.55	29.30	10.30	3.00	1.90	131.00	5.3	-24.0	*/MB15
SDN00002	23.55	29.40	16.70	2.60	2.40	171.00	1.1	-27.4	*/MB15



## 10.70-10.95 GHz, 11.20-11.45 GHz, 12.75-13.25 GHz

1	2	3	4	5	6	7	8	9	10
SEN00000	-48.40	-14.00	14.10	1.10	1.00	148.00	-2.3	-23.8	
SEY00000	42.25	51.50	-3.20	13.80	3.80	48.50	-1.3	-33.8	
SLM00000	147.50	159.00	-9.10	1.50	1.00	147.00	-1.2	-23.0	
SLV00000	-130.50	-89.00	13.70	0.80	0.80	90.00	-6.8	-24.9	
SMA00000	-159.00	-170.70	-14.20	0.80	0.80	90.00	-10.2	-31.1	*/MB2
SMO00000	-125.50	-172.10	-13.70	0.80	0.80	90.00	-6.6	-24.6	
SMR00000	16.50	12.50	43.90	0.80	0.80	90.00	-10.2	-30.3	
SNG00000	98.10	103.90	1.30	0.80	0.80	90.00	-7.3	-25.4	
SOM00000	98.40	46.00	6.30	3.10	1.00	72.00	-0.8	-25.5	
SPM00000	-8.00								1
SRL00000	-51.80	-11.90	8.50	0.80	0.80	90.00	-6.9	-25.4	
STP00000	30.25	7.00	1.00	0.80	0.80	90.00	-7.1	-27.0	
SUI00000	9.45	8.20	46.50	0.80	0.80	90.00	-10.2	-29.4	
SUR00000	-77.00	-55.60	3.90	1.00	0.90	37.00	-3.6	-23.2	
SVK00000	-19.82	17.30	49.60	1.30	1.00	166.00	-5.1	-27.4	
SWZ00000	30.10	31.30	-26.40	0.80	0.80	90.00	-10.2	-30.9	
SYR00000	18.00	38.60	35.30	1.10	1.00	32.00	-7.1	-28.3	
TCD00000	-9.90	18.40	15.60	3.50	1.60	97.00	5.0	-24.1	
TGO00000	-23.15	0.80	8.60	1.10	1.00	116.00	-2.7	-23.2	
THA00000	120.60	100.90	12.80	2.80	1.60	83.00	4.0	-22.6	
TON00000	-128.00	-175.20	-21.20	0.80	0.80	90.00	-6.7	-24.7	
TRD00000	-73.40	-61.10	10.80	0.80	0.80	90.00	-7.2	-27.3	
TUN00000	5.74	9.40	33.50	1.30	1.00	104.00	-5.9	-28.2	
TUR00000	8.50	34.10	38.90	2.80	1.00	171.00	0.0	-26.0	
TUV00000	158.00	179.20	-8.50	0.80	0.80	90.00	-7.1	-27.1	
TZA00000	67.50	35.40	-5.90	2.40	1.40	117.00	-1.3	-27.8	
UAE00000	63.50	53.80	24.90	1.10	1.00	12.00	-9.7	-30.4	
UGA00000	31.50	32.20	0.90	1.50	1.00	70.00	-6.3	-28.9	
UKR00001	38.20	31.73	48.22	2.21	0.97	178.15	-9.1	-31.0	
URG00000	-86.10	-56.30	-33.70	1.10	1.00	58.00	-6.5	-27.7	
USA00000	-101.30								1
USAVIPRT	-101.30								1
UZB00000	110.50	65.45	41.09	1.49	1.05	10.98	-10.2	-31.0	
VCT00000	-93.10	-61.10	13.20	0.80	0.80	90.00	-7.0	-26.2	
VEN00001	-82.70	-66.40	6.80	2.80	2.10	142.00	4.9	-22.8	*/MB17
VEN00002	-82.70	-63.60	15.70	0.80	0.80	90.00	-7.1	-27.0	*/MB17
VTN00000	107.00						2.9	-18.6	3
VUT00000	150.70	168.40	-17.20	1.20	1.00	122.00	-2.4	-23.1	
WAK00000	-159.00	166.50	19.20	0.80	0.80	90.00	-10.2	-31.9	*/MB2
WAL00000	113.00	-177.10	-13.80	0.80	0.80	90.00	-6.0	-24.1	*/MB1
XAN00000	-5.00	-65.60	15.10	1.30	1.00	58.00	-1.1	-22.3	*/MB5
XCQ00000	-159.00	173.40	4.60	10.20	2.40	175.00	16.0	-16.0	*/MB2
XYU00000	43.04	18.70	44.40	1.10	1.00	161.00	-5.6	-27.3	
YEM00001	27.00	44.20	15.10	1.00	1.00	103.00	-9.8	-30.1	
YEM00002	108.00	49.90	14.80	1.40	1.00	53.00	-5.7	-26.9	
ZMB00000	39.55	27.90	-12.80	2.40	1.60	26.00	-3.0	-29.2	
ZWE00000	65.60	30.00	-18.90	1.50	1.10	140.00	-6.0	-28.9	

## ARTICLE 11 (REV.WRC-07)

**Period of validity of the provisions and associated Plan**

11.1 These provisions and associated Plan have been prepared in order to guarantee in practice for all countries equitable access to the GSO and the frequency bands contained in Article 3, to meet the requirements of the fixed-satellite service for a period of at least 20 years from the date of entry into force of this Appendix.

11.2 These provisions and associated Plan shall, in any event, remain in force until their revision by a competent world radiocommunication conference, convened in accordance with the relevant provisions of the ITU Constitution and Convention in force. (WRC-07)

## ANNEX 1 (WRC-03)

**Parameters used in characterizing the fixed-satellite service allotment Plan** (WRC-07)**Section A** (SUP - WRC-07)**1 Basic technical characteristics**

The allotments in the Plan are based on a reference satellite network with the following assumptions:

**1.1 Type of modulation**

The Plan is independent of modulation characteristics and accessing techniques.

**1.2 Parameters used for calculating the earth station and space station power densities**

The carrier-to-noise ratio ( $C/N$ ) is as follows:

- a) the uplink  $C/N$  ratio exceeds 21 dB under rain-faded conditions with a minimum earth station transmitter power density of  $-60$  dB(W/Hz) averaged over the necessary bandwidth of the modulated carrier;
- b) the downlink  $C/N$  ratio exceeds 15 dB under rain-faded conditions;
- c) for the 6/4 GHz bands, the above  $C/N$ s are exceeded for 99.95% of the year  
(NOTE – The rain attenuation margin is limited to a maximum of 8 dB);
- d) for the 13/10-11 GHz bands, the above  $C/N$ s are exceeded for 99.9% of the year  
(NOTE – The rain attenuation margin is limited to a maximum of 8 dB);
- e) the gaseous atmospheric attenuation and rain attenuation models used are those described in Recommendations ITU-R P.676-7 and ITU-R P.618-9. (WRC-07)

### 1.3 Earth station antenna elevation angle

The minimum elevation angle for each test point included in the service area is based on the following:

- 10° for  $Rp \leq 40$  mm/h;
- 20° for  $40 < Rp \leq 70$  mm/h;
- 30° for  $70 < Rp \leq 100$  mm/h;
- 40° for  $Rp > 100$  mm/h.

Where  $Rp$  is the rainfall rate exceeded for any given percentage  $p$  of the average year, calculated in accordance with Recommendation ITU-R P.837-5. Administrations may select lower elevation angles for their service areas. For countries at high latitudes or with dispersed territories, in the absence of such a request, if the above values for minimum elevation angle are unobtainable, then the highest elevation angle leading to a non-zero range of possible orbital positions applies. In mountainous areas, the elevation angles are specified by the administrations concerned. (WRC-07)

### 1.4 Interference criteria

The Plan has been prepared with a view to assuring for each allotment an overall aggregate carrier-to-interference value under free-space conditions of 21 dB or higher, and an overall single entry carrier-to-interference value under free-space conditions of 25 dB. (WRC-07)

### 1.5 Polarization

Polarization isolation between satellite networks was not used in the development of the Allotment Plan.

### 1.6 Earth station characteristics

1.6.1 The diameters of the earth station antennas are:

- 5.5 m for the 6/4 GHz band;
- 2.7 m for the 13/10-11 GHz band. (WRC-07)

1.6.2 The earth station receiving system noise temperature referred to the output of the receiving antenna is:

- 95 K for the 4 GHz band;
- 125 K for the 10-11 GHz band. (WRC-07)

1.6.3 The earth station antenna efficiency is 70%.

1.6.3bis The gains of the earth station antennas for the diameters and the efficiency specified above at the indicated evaluation frequencies are as follows:

- 50.4 dBi at 6 875 MHz;
- 47.0 dBi at 4 650 MHz;
- 49.8 dBi at 13.0 GHz;
- 48.4 dBi at 11.075 GHz. (WRC-07)

1.6.4 The applicable earth station reference antenna pattern is shown in Table 1 below. (WRC-07)

TABLE 1 (WRC-07)

$G_{max} = 10 \log (\eta(\pi D/\lambda)^2)$		dBi				
$G(\varphi) = G_{max} - 2.5 \times 10^{-3} \left( \frac{D}{\lambda} \varphi \right)^2$	for $0 < \varphi < \varphi_m$	dBi				
$G(\varphi) = \min (G_1, 29 - 25 \log \varphi)$	for $\varphi_m \leq \varphi \leq 19.95^\circ$	dBi				
$G(\varphi) = \max (\min (-3.5, 32 - 25 \log \varphi), -10)$	for $\varphi > 19.95^\circ$	dBi				
where:						
<table border="1" style="width: 100%;"> <tr> <td style="padding: 5px;"><math>D</math> : antenna diameter</td> <td rowspan="2" style="font-size: 2em; vertical-align: middle;">}</td> <td rowspan="2" style="padding: 5px;">expressed in the same unit</td> </tr> <tr> <td style="padding: 5px;"><math>\lambda</math> : wavelength</td> </tr> </table>			$D$ : antenna diameter	}	expressed in the same unit	$\lambda$ : wavelength
$D$ : antenna diameter	}	expressed in the same unit				
$\lambda$ : wavelength						
$\varphi$ : off-axis angle of the antenna (degrees)						
<table border="1" style="width: 100%;"> <tr> <td style="padding: 5px;"><math>G_1</math> : gain of the first side lobe = <math>-1 + 15 \log \frac{D}{\lambda}</math></td> <td style="padding: 5px;">dBi</td> </tr> </table>			$G_1$ : gain of the first side lobe = $-1 + 15 \log \frac{D}{\lambda}$	dBi		
$G_1$ : gain of the first side lobe = $-1 + 15 \log \frac{D}{\lambda}$	dBi					
$\varphi_m = \frac{20\lambda}{D} \times \sqrt{G_{max} - G_1} \quad \text{degrees}$						
$\eta$ : antenna efficiency						

**1.7 Space station characteristics** (WRC-07)

1.7.1 The allotment Plan is based on the use of space station antennas with beams of elliptical cross-section.

1.7.2 The antenna radiation characteristics are as shown in Fig. 1.

FIGURE 1\* (WRC-07)

**Reference patterns for satellite antennas with fast roll-off in the main beam**

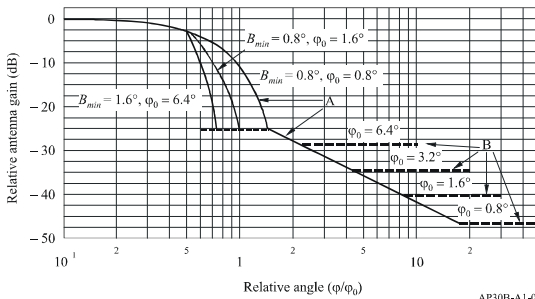

AP30B-A1-01

$G_{max} = 44.45 - 10 \log (\varphi_{01} \cdot \varphi_{02}) \quad \text{dBi} \quad \text{(WRC-07)}$

\* Figure 1 represents patterns for some combinations of  $B_{min}$  and  $\varphi_0$ . (WRC-07)

## AP30B-30

Curve A: dB relative to main beam gain

$$\begin{aligned}
 & -12 (\varphi/\varphi_0)^2 && \text{for } 0 \leq (\varphi/\varphi_0) \leq 0.5 \\
 & -12 \left[ \frac{(\varphi/\varphi_0) - x}{B_{min}/\varphi_0} \right]^2 && \text{for } 0.5 < (\varphi/\varphi_0) \leq \left( \frac{1.45B_{min}}{\varphi_0} + x \right) \\
 & -25.23 && \text{for } \left( \frac{1.45B_{min}}{\varphi_0} + x \right) < (\varphi/\varphi_0) \leq 1.45 \\
 & -(22 + 20 \log (\varphi/\varphi_0)) && \text{for } (\varphi/\varphi_0) > 1.45
 \end{aligned}$$

after intersection with Curve B: Curve B.

Curve B: minus the on-axis gain (Curve B represents examples of four antennas having different values of  $\varphi_0$  as labelled in Fig. 1. The on-axis gains of these antennas are approximately 28.3, 34.3, 40.4 and 46.4 dBi, respectively) (WRC-07)

where:

$\varphi$  : off-axis angle (degrees)

$\varphi_0$  : cross-sectional half-power beamwidth in the direction of interest (degrees)

$\varphi_{01}, \varphi_{02}$  : major and minor axis half-power beamwidth, respectively, of elliptical beam (degrees) (WRC-07)

$$x = 0.5 \left( 1 - \frac{B_{min}}{\varphi_0} \right)$$

where:

$$B_{min} = \begin{cases} 0.8^\circ & \text{for 13/10-11 GHz} \\ 1.6^\circ & \text{for 6/4 GHz} \end{cases}$$

1.7.3 The space station receiving system noise temperature referred to the output of the receiving antenna is:

500 K for the 6 GHz band;

550 K for the 13 GHz band.

1.7.4 The minimum beamwidth size, in terms of the half-power beamwidth, is 1.6° for the 6/4 GHz band and 0.8° for the 13/10-11 GHz band.

1.7.5 The space station antenna efficiency is 55%.

1.7.6 The deviation of the space station antenna beam from its nominal pointing direction is limited to 0.1° in any direction. The rotation accuracy of elliptical beams is  $\pm 1.0^\circ$ .

## 1.8 Bandwidth

The allotment Plan is based on the carrier power averaged over the necessary bandwidth of the modulated carrier and referred to a 1 MHz bandwidth.

**Section B** (SUP - WRC-07)

## ANNEX 2 (SUP - WRC-07)

## ANNEX 3 (REV.WRC-19)

**Limits applicable to submissions received under Article 6 or Article 7<sup>15</sup>**

Under assumed free-space propagation conditions, the power flux-density (space-to-Earth) of a proposed new allotment or assignment produced on any portion of the surface of the Earth shall not exceed:

- -131.4 dB(W/(m<sup>2</sup> · MHz)) in the frequency band 4 500-4 800 MHz; and
- -118.4 dB(W/(m<sup>2</sup> · MHz)) in the frequency bands 10.70-10.95 GHz and 11.20-11.45 GHz.

Under assumed free-space propagation conditions, the power flux-density (Earth-to-space) of a proposed new allotment or assignment shall not exceed:

- -140.0 dB(W/(m<sup>2</sup> · MHz)) towards any location in the geostationary-satellite orbit located more than 7° from the proposed orbital position in the frequency band 6 725-7 025 MHz, and
- -133.0 dB(W/(m<sup>2</sup> · MHz)) towards any location in the geostationary-satellite orbit located more than 6° from the proposed orbital position in the frequency band 12.75-13.25 GHz.

---

<sup>15</sup> These limits shall not apply to assignments submitted in accordance with Article 6 or recorded in the List before 23 November 2019. For assignments submitted under § 6.17 after 22 November 2019, related to assignments submitted under § 6.1 before 23 November 2019, the limits specified in Annex 3 (Rev.WRC-07) apply. (WRC-19)

ANNEX 4 (REV.WRC-19)

**Criteria for determining whether an allotment or an assignment is considered to be affected<sup>15bis</sup>**

An allotment or an assignment is considered as being affected by a proposed new allotment or assignment:

1 if the orbital spacing between its orbital position and the orbital position of the proposed new allotment or assignment is equal to or less than:

1.1 7° in the frequency bands 4 500-4 800 MHz (space-to-Earth) and 6 725-7 025 MHz (Earth-to-space);

1.2 6° in the frequency bands 10.70-10.95 GHz (space-to-Earth), 11.20-11.45 GHz (space-to-Earth) and 12.75-13.25 GHz (Earth-to-space).

2 However, an allotment or an assignment is considered as not being affected if at least one of the following conditions is satisfied:

2.1 the calculated<sup>16</sup> Earth-to-space single-entry carrier-to-interference  $(C/I)_u$  value at each test point associated with the allotment or assignment under consideration is greater than or equal to a reference value that is 30 dB, or  $(C/N)_u + 9$  dB<sup>17, 17bis</sup>, whichever is the lowest, and the calculated<sup>16</sup> space-to-Earth single-entry  $(C/I)_d$  value everywhere within the service area of the allotment or assignment under consideration is greater than or equal to a reference value<sup>19</sup> that is 26.65 dB, or  $(C/N)_d + 11.65$  dB<sup>20, 20bis</sup>, whichever is the lowest, and the calculated<sup>16</sup> overall aggregate  $(C/I)_{agg}$  value at each test point associated with the allotment or assignment under consideration is greater than or equal to a reference value that is 21 dB, or  $(C/N)_t + 7$  dB<sup>21</sup>, or any already accepted overall

---

<sup>15bis</sup> For frequency assignments recorded in the List and brought into use before 23 November 2019, the criteria of § 2.2 of this Annex are not applicable. (WRC-19)

<sup>16</sup> Including a computational precision of 0.05 dB.

<sup>17</sup>  $C/N_u$  is calculated as in Appendix 2 to this Annex.

<sup>17bis</sup> Any already accepted Earth-to-space single-entry  $(C/I)_u$  value, excluding values accepted in accordance with § 6.15 of Article 6, could be used by administrations during coordination of their respective networks. The Bureau shall continue to make available any already accepted Earth-to-space single-entry  $(C/I)_u$  value. (WRC-19)

<sup>18</sup> (SUP - WRC-19)

<sup>19</sup> The reference values within the service area are interpolated from the reference values on the test points.

<sup>20</sup>  $C/N_d$  is calculated as in Appendix 2 to this Annex.

<sup>20bis</sup> Any already accepted space-to-Earth single-entry  $(C/I)_d$  value could be used by administrations during coordination of their respective networks. The Bureau shall continue to make available any already accepted space-to-Earth single-entry  $(C/I)_d$  value. (WRC-19)

<sup>21</sup>  $(C/N)_t$  is calculated as in Appendix 2 of this Annex.

aggregate  $(C/I)_{agg}$  value, whichever is the lowest, with a tolerance of 0.25 dB<sup>22</sup> in the case of assignments not stemming from the conversion of an allotment into an assignment without modification, or when the modification is within the envelope characteristics of the initial allotment;

2.2 in the frequency band 6 725-7 025 MHz (Earth-to-space), the pfd produced at the location in the geostationary-satellite orbit of the allotment or assignment under consideration under assumed free-space propagation conditions does not exceed  $-204.0 - G_{Rx}$  dB(W/(m<sup>2</sup> · Hz)), where  $G_{Rx}$  (dB) is the relative space station uplink receive antenna gain of the potentially affected assignment at the location of the interfering earth station;

in the frequency band 4 500-4 800 MHz (space-to-Earth), the pfd produced under assumed free-space propagation conditions does not exceed the threshold values shown below, anywhere within the service area of the allotment or assignment under consideration:

$0^\circ \leq \theta \leq 0.09^\circ$	-243.5	dB(W/(m <sup>2</sup> · Hz))
$0.09^\circ < \theta \leq 3^\circ$	$-243.5 + 20\log(\theta/0.09)$	dB(W/(m <sup>2</sup> · Hz))
$3^\circ < \theta \leq 5.5^\circ$	$-219.79 + 0.75 \cdot \theta^2$	dB(W/(m <sup>2</sup> · Hz))
$5.5^\circ < \theta \leq 7^\circ$	$-197.1 + 25\log(\theta/5.5)$	dB(W/(m <sup>2</sup> · Hz))

where  $\theta$  denotes nominal geocentric separation (degrees) between interfering and interfered-with satellite networks;

in the frequency band 12.75-13.25 GHz (Earth-to-space), the pfd produced at the location in the geostationary-satellite orbit of the allotment or assignment under consideration under assumed free-space propagation conditions does not exceed  $-208.0 - G_{Rx}$  dB(W/(m<sup>2</sup> · Hz)), where  $G_{Rx}$  (dB) is the relative space station uplink receive antenna gain of the potentially affected assignment at the location of the interfering earth station;

in the frequency bands 10.7-10.95 GHz and 11.2-11.45 GHz (space-to-Earth), the pfd produced under assumed free-space propagation conditions does not exceed the threshold values shown below, anywhere within the service area of the allotment or assignment under consideration:

$0^\circ \leq \theta \leq 0.05^\circ$	-238.0	dB(W/(m <sup>2</sup> · Hz))
$0.05^\circ < \theta \leq 3^\circ$	$-238.0 + 20\log(\theta/0.05)$	dB(W/(m <sup>2</sup> · Hz))
$3^\circ < \theta \leq 5^\circ$	$-210.98 + 0.95 \cdot \theta^2$	dB(W/(m <sup>2</sup> · Hz))
$5^\circ < \theta \leq 6^\circ$	$-187.23 + 25\log(\theta/5)$	dB(W/(m <sup>2</sup> · Hz))

where  $\theta$  denotes nominal geocentric separation (degrees) between interfering and interfered-with satellite networks.

<sup>22</sup> Inclusive of the 0.05 dB computational precision.



**Method for determination of the overall single-entry and aggregate carrier-to-interference value averaged over the necessary bandwidth of the modulated carrier**

**1 Single-entry C/I**

This section describes the method for calculating the single-entry interference potential.

The method is based on the single-entry carrier-to-interference ratio (C/I) which a given allotment or assignment made in accordance with the provisions of Appendix 30B might experience due to an emission from the proposed new assignment or modification. The single-entry uplink (C/I)<sub>u</sub> and downlink (C/I)<sub>d</sub> values due to a single interfering satellite network are given by:

$$(C/I)_u = 10 \log_{10} \left( \frac{p_1 g_1 g_2(\varphi) l_{su}'}{p_1' g_1'(\theta) g_2(\rho) l_{su}} \right) \quad \text{dB}$$

$$(C/I)_d = 10 \log_{10} \left( \frac{p_3 g_3(\eta) g_4(\xi) l_{sd}'}{p_3' g_3'(\eta) g_4(\xi) l_{sd}} \right) \quad \text{dB}$$

FIGURE 1

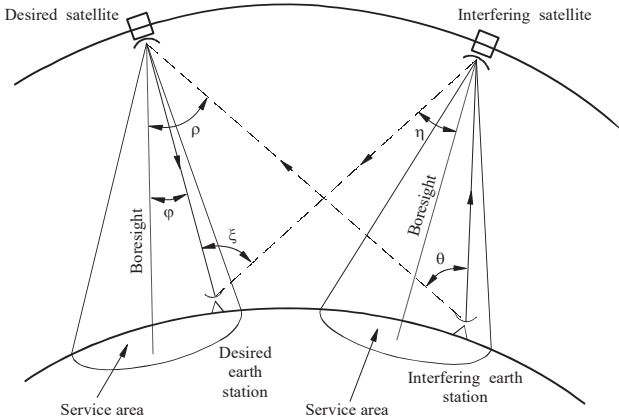

AP30BA1-A4-01

where:

$\theta, \varphi, \rho, \eta, \xi$  are angles as defined in Fig. 1 above.

In the following, all ratios are numerical power ratios:

- $p_1$ : power density, averaged over the necessary bandwidth of the modulated carrier, fed into the desired earth station transmitting antenna (W/Hz)
- $g_1$ : maximum gain of the desired transmitting earth station antenna
- $l_{su}$ : free-space path loss of the desired up-path signal
- $l_{su'}$ : free-space path loss of the interfering up-path signal
- $g_2(\varphi)$ : gain of the desired space station receiving antenna in the direction of the desired earth station
- $g_2$ : maximum gain of the desired space station receiving antenna
- $p_1'$ : power density, averaged over the necessary bandwidth of the modulated carrier, fed into the interfering earth station transmitting antenna (W/Hz)
- $g_1'(\theta)$ : interfering earth station antenna gain in the direction of the desired satellite
- $l_{sd}$ : free-space path loss of the desired down-path signal
- $l_{sd'}$ : free-space path loss of the interfering down-path signal
- $g_2(\rho)$ : gain of the desired space station receiving antenna in the direction of the interfering earth station
- $p_3$ : power density, averaged over the necessary bandwidth of the modulated carrier, fed into the desired space station transmitting antenna (W/Hz)
- $g_3(\varphi)$ : desired space station transmitting antenna gain in the direction of the desired earth station
- $g_3$ : maximum gain of the desired space station transmitting antenna
- $g_4$ : maximum gain of the desired receiving earth station antenna
- $p_3'$ : power density, averaged over the necessary bandwidth of the modulated carrier, fed into the interfering space station transmitting antenna (W/Hz)
- $g_3'(\eta)$ : interfering space station transmitting antenna gain in the direction of the desired earth station
- $g_4(\xi)$ : desired earth station receiving antenna gain in the direction of the interfering satellite.

The overall single-entry  $(C/I)_t$  at a given downlink test point due to a single interfering allotment or assignment is given by:

$$(C/I)_t = -10 \log_{10} \left[ 10^{-\frac{(C/N)_{u_{min}}}{10}} + 10^{-\frac{(C/N)_d}{10}} \right] \quad \text{dB}$$

where:

$(C/N)_{u_{min}}$ : lowest uplink  $C/I$  value among all uplink test points

$(C/N)_d$ : downlink  $C/I$  value at the test point under consideration.

NOTE – When only one of the uplink or the downlink is implemented in the bands subject to Appendix 30B, only the contribution from the link that is implemented in the bands subject to Appendix 30B shall be considered in calculating  $(C/I)_t$ .

## 2 Aggregate C/I

The aggregate  $(C/I)_{agg}$  at a given downlink test point is given by:

$$(C/I)_{agg} = -10 \log_{10} \left( \sum_j^n 10^{-\frac{(C/I)_{tj}}{10}} \right) \quad \text{dB}$$

$$j = 1, 2, 3 \dots n,$$

where:

- $(C/I)_{tj}$ : overall carrier-to-interference ratio due to interference from the  $j$ -th allotment or assignment calculated using the method for overall single-entry  $(C/I)_t$  as provided in § 1 of Appendix 1 to this Annex; and
- $n$ : total number of interfering allotments or assignments for which the orbital separation with the desired satellite is less than or equal to  $10^\circ$  in the case of the 6/4 GHz band and less than or equal to  $9^\circ$  in the case of the 13/10-11 GHz band.

### APPENDIX 2 TO ANNEX 4 (WRC-07)

#### Method for determination of the carrier-to-noise $(C/N)$ values

The uplink carrier-to noise value  $(C/N)_u$  and the downlink carrier-to-noise value  $(C/N)_d$  are calculated as follows:

$$(C/N)_u = 10 \log_{10} \left( \frac{p_1 \cdot g_1 \cdot g_2(\varphi)}{k \cdot T_s \cdot l_{su}} \right) \quad \text{dB}$$

$$(C/N)_d = 10 \log_{10} \left( \frac{p_3 \cdot g_4 \cdot g_3(\varphi)}{k \cdot T_e \cdot l_{sd}} \right) \quad \text{dB}$$

where:

In the following, all ratios are numerical power ratios.

- $p_1$ : power density, averaged over the necessary bandwidth of the modulated carrier, fed into the earth station transmitting antenna (W/Hz)
- $g_1$ : maximum gain of the transmitting earth station antenna
- $l_{su}$ : free-space path loss of the up-path signal
- $g_2(\varphi)$ : gain of the space station receiving antenna in the direction of the earth station
- $T_s$ : space station receiving system noise temperature referred to the output of the receiving antenna
- $p_3$ : power density, averaged over the necessary bandwidth of the modulated carrier, fed into the space station transmitting antenna (W/Hz)
- $g_3(\varphi)$ : space station transmitting antenna gain in the direction of the earth station
- $l_{sd}$ : free-space path loss of the down-path signal

- $g_4$ : maximum gain of the receiving earth station antenna
- $T_e$ : earth station receiving system noise temperature, referred to the output of the receiving antenna
- $k$ : Boltzmann's constant.

The overall carrier-to-noise value  $(C/N)_t$  is then calculated as follows:

$$(C/N)_t = -10 \log_{10} \left[ 10^{-\frac{(C/N)_{u_{min}}}{10}} + 10^{-\frac{(C/N)_d}{10}} \right] \quad \text{dB}$$

where:

$(C/N)_{u_{min}}$ : lowest uplink  $C/N$  value among all test points

$(C/N)_d$ : downlink  $C/N$  value at the test point under consideration.

NOTE – When only one of the uplink or the downlink is implemented in the bands subject to Appendix 30B, only the contribution from the link that is implemented in the bands subject to Appendix 30B shall be considered in calculating  $(C/N)_t$ .

ANNEX 5 (SUP - WRC-07)

ANNEX 6 (SUP - WRC-07)



## APPENDIX 42 (REV.WRC-19)

**Table of allocation of international call sign series**

(See Article 19)

Call sign series	Allocated to
AAA-ALZ	United States of America
AMA-AOZ	Spain
APA-ASZ	Pakistan (Islamic Republic of)
ATA-AWZ	India (Republic of)
AXA-AXZ	Australia
AYA-AZZ	Argentine Republic
A2A-A2Z	Botswana (Republic of)
A3A-A3Z	Tonga (Kingdom of)
A4A-A4Z	Oman (Sultanate of)
A5A-A5Z	Bhutan (Kingdom of)
A6A-A6Z	United Arab Emirates
A7A-A7Z	Qatar (State of)
A8A-A8Z	Liberia (Republic of)
A9A-A9Z	Bahrain (Kingdom of)
BAA-BZZ	China (People's Republic of)
CAA-CEZ	Chile
CFA-CKZ	Canada
CLA-CMZ	Cuba
CNA-CNZ	Morocco (Kingdom of)
COA-COZ	Cuba
CPA-CPZ	Bolivia (Republic of)
CQA-CUZ	Portugal
CVA-CXZ	Uruguay (Eastern Republic of)
CYA-CZZ	Canada
C2A-C2Z	Nauru (Republic of)
C3A-C3Z	Andorra (Principality of)
C4A-C4Z	Cyprus (Republic of)
C5A-C5Z	Gambia (Republic of the)
C6A-C6Z	Bahamas (Commonwealth of the)
*C7A-C7Z	World Meteorological Organization
C8A-C9Z	Mozambique (Republic of)
DAA-DRZ	Germany (Federal Republic of)
DSA-DTZ	Korea (Republic of)
DUA-DZZ	Philippines (Republic of the)
D2A-D3Z	Angola (Republic of)
D4A-D4Z	Cape Verde (Republic of)
D5A-D5Z	Liberia (Republic of)
D6A-D6Z	Comoros (Union of)
D7A-D9Z	Korea (Republic of)

Call sign series	Allocated to	
EAA-EHZ	Spain	
EIA-EJZ	Ireland	
EKA-EKZ	Armenia (Republic of)	
ELA-ELZ	Liberia (Republic of)	
EMA-EOZ	Ukraine	
EPA-EQZ	Iran (Islamic Republic of)	
ERA-ERZ	Moldova (Republic of)	
ESA-ESZ	Estonia (Republic of)	
ETA-ETZ	Ethiopia (Federal Democratic Republic of)	
EUA-EWZ	Belarus (Republic of)	
EXA-EXZ	Kyrgyz Republic	
EYA-EYZ	Tajikistan (Republic of)	
EZA-EZZ	Turkmenistan	
E2A-E2Z	Thailand	
E3A-E3Z	Eritrea	
E4A-E4Z	Palestinian Authority <sup>1</sup>	
E5A-E5Z	New Zealand – Cook Islands	(WRC-07)
E6A-E6Z	New Zealand – Niue	(WRC-15)
E7A-E7Z	Bosnia and Herzegovina	(WRC-07)
FAA-FZZ	France	
GAA-GZZ	United Kingdom of Great Britain and Northern Ireland	
HAA-HAZ	Hungary (Republic of)	
HBA-HBZ	Switzerland (Confederation of)	
HCA-HDZ	Ecuador	
HEA-HEZ	Switzerland (Confederation of)	
HFA-HFZ	Poland (Republic of)	
HGA-HGZ	Hungary (Republic of)	
HHA-HHZ	Haiti (Republic of)	
HIA-HIZ	Dominican Republic	
HJA-HKZ	Colombia (Republic of)	
HLA-HLZ	Korea (Republic of)	
HMA-HMZ	Democratic People's Republic of Korea	
HNA-HNZ	Iraq (Republic of)	
HOA-HPZ	Panama (Republic of)	
HQA-HRZ	Honduras (Republic of)	
HSA-HSZ	Thailand	
HTA-HTZ	Nicaragua	
HUA-HUZ	El Salvador (Republic of)	
HVA-HVZ	Vatican City State	
HWA-HYZ	France	
HZA-HZZ	Saudi Arabia (Kingdom of)	
H2A-H2Z	Cyprus (Republic of)	
H3A-H3Z	Panama (Republic of)	
H4A-H4Z	Solomon Islands	
H6A-H7Z	Nicaragua	
H8A-H9Z	Panama (Republic of)	
IAA-IZZ	Italy	

<sup>1</sup> In response to Resolution 99 (Rev. Busan, 2014) of the Plenipotentiary Conference. (WRC-15)

Call sign series	Allocated to
JAA-JSZ	Japan
JTA-JVZ	Mongolia
JWA-JXZ	Norway
JYA-JYZ	Jordan (Hashemite Kingdom of)
JZA-JZZ	Indonesia (Republic of)
J2A-J2Z	Djibouti (Republic of)
J3A-J3Z	Grenada
J4A-J4Z	Greece
J5A-J5Z	Guinea-Bissau (Republic of)
J6A-J6Z	Saint Lucia
J7A-J7Z	Dominica (Commonwealth of)
J8A-J8Z	Saint Vincent and the Grenadines
KAA-KZZ	United States of America
LAA-LNZ	Norway
LOA-LWZ	Argentine Republic
LXA-LXZ	Luxembourg
LYA-LYZ	Lithuania (Republic of)
LZA-LZZ	Bulgaria (Republic of)
L2A-L9Z	Argentine Republic
MAA-MZZ	United Kingdom of Great Britain and Northern Ireland
NAA-NZZ	United States of America
OAA-OCZ	Peru
ODA-ODZ	Lebanon
OEA-OEZ	Austria
OFA-OJZ	Finland
OKA-OLZ	Czech Republic
OMA-OMZ	Slovak Republic
ONA-OTZ	Belgium
OUA-OZZ	Denmark
PAA-PIZ	Netherlands (Kingdom of the)
PJA-PJZ	Netherlands (Kingdom of the) – Curaçao, Sint Maarten (Dutch part), and the Netherlands Caribbean
PKA-POZ	Indonesia (Republic of)
PPA-PYZ	Brazil (Federative Republic of)
PZA-PZZ	Suriname (Republic of)
P2A-P2Z	Papua New Guinea
P3A-P3Z	Cyprus (Republic of)
P4A-P4Z	Netherlands (Kingdom of the) – Aruba
P5A-P9Z	Democratic People's Republic of Korea
RAA-RZZ	Russian Federation

(WRC-19)



Call sign series	Allocated to
SAA-SMZ	Sweden
SNA-SRZ	Poland (Republic of)
SSA-SSM	Egypt (Arab Republic of)
SSN-STZ	Sudan (Republic of the)
SUA-SUZ	Egypt (Arab Republic of)
SVA-SZZ	Greece
S2A-S3Z	Bangladesh (People's Republic of)
S5A-S5Z	Slovenia (Republic of)
S6A-S6Z	Singapore (Republic of)
S7A-S7Z	Seychelles (Republic of)
S8A-S8Z	South Africa (Republic of)
S9A-S9Z	Sao Tome and Principe (Democratic Republic of)
TAA-TCZ	Turkey
TDA-TDZ	Guatemala (Republic of)
TEA-TEZ	Costa Rica
TFA-TFZ	Iceland
TGA-TGZ	Guatemala (Republic of)
THA-THZ	France
TIA-TIZ	Costa Rica
TJA-TJZ	Cameroon (Republic of)
TKA-TKZ	France
TLA-TLZ	Central African Republic
TMA-TMZ	France
TNA-TNZ	Congo (Republic of the)
TOA-TQZ	France
TRA-TRZ	Gabonese Republic
TSA-TSZ	Tunisia
TTA-TTZ	Chad (Republic of)
TUA-TUZ	Côte d'Ivoire (Republic of)
TVA-TXZ	France
TYA-TYZ	Benin (Republic of)
TZA-TZZ	Mali (Republic of)
T2A-T2Z	Tuvalu
T3A-T3Z	Kiribati (Republic of)
T4A-T4Z	Cuba
T5A-T5Z	Somali Democratic Republic
T6A-T6Z	Afghanistan
T7A-T7Z	San Marino (Republic of)
T8A-T8Z	Palau (Republic of)
UAA-UIZ	Russian Federation
UJA-UMZ	Uzbekistan (Republic of)
UNA-UQZ	Kazakhstan (Republic of)
URA-UZZ	Ukraine

Call sign series	Allocated to
VAA-VGZ	Canada
VHA-VNZ	Australia
VOA-VOZ	Canada
VPA-VQZ	United Kingdom of Great Britain and Northern Ireland
VRA-VRZ	China (People's Republic of) – Hong Kong
VSA-VSZ	United Kingdom of Great Britain and Northern Ireland
VTA-VWZ	India (Republic of)
VXA-VYZ	Canada
VZA-VZZ	Australia
V2A-V2Z	Antigua and Barbuda
V3A-V3Z	Belize
V4A-V4Z	Saint Kitts and Nevis (Federation of)
V5A-V5Z	Namibia (Republic of)
V6A-V6Z	Micronesia (Federated States of)
V7A-V7Z	Marshall Islands (Republic of the)
V8A-V8Z	Brunei Darussalam
WAA-WZZ	United States of America
XAA-XIZ	Mexico
XJA-XOZ	Canada
XPA-XPZ	Denmark
XQA-XRZ	Chile
XSA-XSZ	China (People's Republic of)
XTA-XTZ	Burkina Faso
XUA-XUZ	Cambodia (Kingdom of)
XVA-XVZ	Viet Nam (Socialist Republic of)
XWA-XWZ	Lao People's Democratic Republic
XXA-XXZ	China (People's Republic of) – Macao
XYA-XXZ	Myanmar (Union of)
YAA-YAZ	Afghanistan
YBA-YHZ	Indonesia (Republic of)
YIA-YIZ	Iraq (Republic of)
YJA-YJZ	Vanuatu (Republic of)
YKA-YKZ	Syrian Arab Republic
YLA-YLZ	Latvia (Republic of)
YMA-YMZ	Turkey
YNA-YNZ	Nicaragua
YOA-YRZ	Romania
YSA-YSZ	El Salvador (Republic of)
YTA-YUZ	Serbia (Republic of)
YVA-YYZ	Venezuela (Bolivarian Republic of)
Y2A-Y9Z	Germany (Federal Republic of)
ZAA-ZAZ	Albania (Republic of)
ZBA-ZJZ	United Kingdom of Great Britain and Northern Ireland
ZKA-ZMZ	New Zealand
ZNA-ZOZ	United Kingdom of Great Britain and Northern Ireland
ZPA-ZPZ	Paraguay (Republic of)

(WRC-07)

(WRC-07)

Call sign series	Allocated to	
ZQA-ZQZ	United Kingdom of Great Britain and Northern Ireland	
ZRA-ZUZ	South Africa (Republic of)	
ZVA-ZZZ	Brazil (Federative Republic of)	
Z2A-Z2Z	Zimbabwe (Republic of)	
Z3A-Z3Z	North Macedonia	(WRC-19)
Z8A-Z8Z	South Sudan (Republic of)	(WRC-15)
2AA-2ZZ	United Kingdom of Great Britain and Northern Ireland	
3AA-3AZ	Monaco (Principality of)	
3BA-3BZ	Mauritius (Republic of)	
3CA-3CZ	Equatorial Guinea (Republic of)	
3DA-3DM	Eswatini (Kingdom of)	(WRC-19)
3DN-3DZ	Fiji (Republic of)	
3EA-3FZ	Panama (Republic of)	
3GA-3GZ	Chile	
3HA-3UZ	China (People's Republic of)	
3VA-3VZ	Tunisia	
3WA-3WZ	Viet Nam (Socialist Republic of)	
3XA-3XZ	Guinea (Republic of)	
3YA-3YZ	Norway	
3ZA-3ZZ	Poland (Republic of)	
4AA-4CZ	Mexico	
4DA-4IZ	Philippines (Republic of the)	
4JA-4KZ	Azerbaijani Republic	
4LA-4LZ	Georgia	
4MA-4MZ	Venezuela (Bolivarian Republic of)	
4OA-4OZ	Montenegro	(WRC-07)
4PA-4SZ	Sri Lanka (Democratic Socialist Republic of)	
4TA-4TZ	Peru	
*4UA-4UZ	United Nations	
4VA-4VZ	Haiti (Republic of)	
4WA-4WZ	Timor-Leste (Democratic Republic of)	(WRC-03)
4XA-4XZ	Israel (State of)	
*4YA-4YZ	International Civil Aviation Organization	
4ZA-4ZZ	Israel (State of)	
5AA-5AZ	Libya	
5BA-5BZ	Cyprus (Republic of)	
5CA-5GZ	Morocco (Kingdom of)	
5HA-5IZ	Tanzania (United Republic of)	
5JA-5KZ	Colombia (Republic of)	
5LA-5MZ	Liberia (Republic of)	
5NA-5OZ	Nigeria (Federal Republic of)	
5PA-5QZ	Denmark	
5RA-5SZ	Madagascar (Republic of)	
5TA-5TZ	Mauritania (Islamic Republic of)	
5UA-5UZ	Niger (Republic of the)	
5VA-5VZ	Togolese Republic	
5WA-5WZ	Samoa (Independent State of)	
5XA-5XZ	Uganda (Republic of)	
5YA-5ZZ	Kenya (Republic of)	

Call sign series	Allocated to
6AA-6BZ	Egypt (Arab Republic of)
6CA-6CZ	Syrian Arab Republic
6DA-6JZ	Mexico
6KA-6NZ	Korea (Republic of)
6OA-6OZ	Somali Democratic Republic
6PA-6SZ	Pakistan (Islamic Republic of)
6TA-6UZ	Sudan (Republic of the)
6VA-6WZ	Senegal (Republic of)
6XA-6XZ	Madagascar (Republic of)
6YA-6YZ	Jamaica
6ZA-6ZZ	Liberia (Republic of)
7AA-7IZ	Indonesia (Republic of)
7JA-7NZ	Japan
7OA-7OZ	Yemen (Republic of)
7PA-7PZ	Lesotho (Kingdom of)
7QA-7QZ	Malawi
7RA-7RZ	Algeria (People's Democratic Republic of)
7SA-7SZ	Sweden
7TA-7YZ	Algeria (People's Democratic Republic of)
7ZA-7ZZ	Saudi Arabia (Kingdom of)
8AA-8IZ	Indonesia (Republic of)
8JA-8NZ	Japan
8OA-8OZ	Botswana (Republic of)
8PA-8PZ	Barbados
8QA-8QZ	Maldives (Republic of)
8RA-8RZ	Guyana
8SA-8SZ	Sweden
8TA-8YZ	India (Republic of)
8ZA-8ZZ	Saudi Arabia (Kingdom of)
9AA-9AZ	Croatia (Republic of)
9BA-9DZ	Iran (Islamic Republic of)
9EA-9FZ	Ethiopia (Federal Democratic Republic of)
9GA-9GZ	Ghana
9HA-9HZ	Malta
9IA-9JZ	Zambia (Republic of)
9KA-9KZ	Kuwait (State of)
9LA-9LZ	Sierra Leone
9MA-9MZ	Malaysia
9NA-9NZ	Nepal (Federal Democratic Republic of)
9OA-9TZ	Democratic Republic of the Congo
9UA-9UZ	Burundi (Republic of)
9VA-9VZ	Singapore (Republic of)
9WA-9WZ	Malaysia
9XA-9XZ	Rwanda (Republic of)
9YA-9ZZ	Trinidad and Tobago

\* Series allocated to an international organization.





ISBN 978-92-61-30301-3

SAP id

4 3 5 1 3



9 789261 303013

Published in Switzerland  
Geneva, 2020